

SIEMENS

MICROMASTER PROFIBUS Optional Board

Operating Instructions

Edition 02/02



This PROFIBUS Optional Board can be used together with the following MICROMASTER-Inverters:

MICROMASTER 420
0.12 kW to 11 kW



MICROMASTER 430
7.5 kW to 90 kW



MICROMASTER 440
0.12 kW to 75 kW



MICROMASTER 440,
90 kW to 200 kW



SIEMENS

MICROMASTER PROFIBUS Optional Board

Operating Instructions
User Documentation

Valid for

Edition 02/02

Converter Type
MICROMASTER 4

Edition 02/02

Description	1
General Definition	2
Communication	3
Connection	4
Start-Up	5
Links to Master Systems	6
Diagnostics and Troubleshooting	7
Appendix	8
Glossary	9

Further information can be obtained from Internet website:
<http://www.siemens.de/micromaster>

Approved Siemens Quality for Software and Training
is to DIN ISO 9001, Reg. No. 2160-01

The reproduction, transmission or use of this document, or its contents is not permitted unless authorized in writing. Offenders will be liable for damages. All rights including rights created by patent grant or registration of a utility model or design are reserved.

© Siemens AG 2001. All Rights Reserved.

MICROMASTER® is a registered trademark of Siemens

Other functions not described in this document may be available. However, this fact shall not constitute an obligation to supply such functions with a new control, or when servicing.

We have checked that the contents of this document correspond to the hardware and software described. There may be discrepancies nevertheless, and no guarantee can be given that they are completely identical. The information contained in this document is reviewed regularly and any necessary changes will be included in the next edition. We welcome suggestions for improvement.

Siemens handbooks are printed on chlorine-free paper that has been produced from managed sustainable forests. No solvents have been used in the printing or binding process.

Document subject to change without prior notice.

Definitions, warnings

Qualified personnel

For the purpose of this Instruction Manual and product labels, a "Qualified person" is someone who is familiar with the installation, mounting, start-up and operation of the equipment and the hazards involved.

He or she must have the following qualifications:

- Trained and authorized to energize, de-energize, clear, ground and tag circuits and equipment in accordance with established safety procedures.
- Trained in the proper care and use of protective equipment in accordance with established safety procedures.
- Trained in rendering first aid.

Safety guidelines

This manual contains notices intended to ensure your personal safety, as well as to protect products and connected equipment against damage. Information relating to your personal safety is highlighted by a warning triangle. Warnings about property damage are displayed without a warning triangle. Depending on the degree of risk involved, safety-related information is presented in the following categories:



DANGER

For the purpose of this documentation and the product warning labels, "Danger" indicates that death, severe personal injury or substantial damage to property **will** result if proper precautions are not taken.



WARNING

For the purpose of this documentation and the product warning labels, "Warning" indicates that death, severe personal injury or substantial damage to property **can** result if proper precautions are not taken.



CAUTION

With a warning triangle, "Caution" indicates that minor personal injury can result if proper precautions are not taken.

CAUTION

Without a warning triangle, "Caution" indicates that material damage can result if proper precautions are not taken.

ATTENTION

indicates that an undesirable effect or state can occur if attention is not paid to the advice given.

NOTE

For the purpose of this documentation, "Note" indicates important information relating to the product or highlights part of the documentation for special attention.

User documentation



WARNING

Before installing and commissioning, please read these safety instructions and warnings carefully and all the warning labels attached to the equipment. Make sure that the warning labels are kept in a legible condition and replace missing or damaged labels.

Proper use

Please note the following:



WARNING

This equipment contains dangerous voltages and controls potentially dangerous rotating mechanical parts.

Non-compliance with Warnings or failure to follow the instructions contained in this manual can result in loss of life, severe personal injury or serious damage to property.

Only suitably qualified personnel should work on this equipment, and only after becoming familiar with all safety notices and maintenance procedures contained in this manual.

The successful and safe operation of this equipment is dependent upon its proper handling, storage, installation, operation and maintenance.

National safety regulations are also applicable.

Common Notes

NOTES

- This operating manual does not purport to cover all details or variations in equipment, or to provide for every possible contingency to be met in connection with installation, operation or maintenance.
 - Should further information be desired or should particular problems arise which are not covered sufficiently for the Purchaser's purposes, the matter should be referred to the local Siemens Sales Office.
 - The contents of this operating manual shall not become part of or modify any prior or existing agreement, commitment or relationship. The Sales Contract contains the entire obligations of Siemens. The warranty contained in the contract between the parties is the sole warranty of Siemens. Any statements contained herein do not create new warranties or modify the existing warranty.
-

Table of Contents

1	Description of MICROMASTER PROFIBUS Optional Board	9
2	General Definition of PROFIBUS-DP	11
3	Communication with MICROMASTER 4 via PROFIBUS-DP	15
3.1	Cyclical data of MICROMASTER 4 via PROFIBUS-DP	16
3.1.1	User data structure as defined in PROFIdrive Profile 2.0 and 3.0	16
1.1.2	MICROMASTER 4 reaction time	19
1.2	Acyclic data transmission	20
1.3	Control and status words	21
1.3.1	Control word 1	21
1.3.2	Default assignment control word 2	23
1.3.3	Status word 1	24
1.3.4	Status word 2	25
1.4	PKW mechanism for processing parameters	26
1.1.1	Example for using the PKW mechanism via PROFIBUS	31
4	Connection to PROFIBUS-DP	35
4.1	Installing the PROFIBUS-DP board for Frame Sizes A, B and C	35
4.2	Installation of the PROFIBUS-DP component in Frame sizes D, E, F	36
4.3	Installation of the PROFIBUS-DP component in Frame sizes FX, GX	37
4.4	PROFIBUS connection on communication board	39
4.4.1	Connection of the external 24 V voltage supply	39
4.5	Connecting the bus cable using RS485 bus connectors	40
4.5.1	Maximum cable lengths	40
4.5.2	Bus connector	41
4.5.3	Bus terminator	42
4.5.4	Removing a bus connector	42
4.5.5	Screening the bus cable / EMC precautions	43
5	Starting up the PROFIBUS Board	45
5.1	PROFIBUS address	45
5.2	Communication board parameters	47
5.2.1	Starting process for the MICROMASTER 4 with communication board	50
6	Links to PROFIBUS-DP Master Systems	53
6.1	General	53
6.2	Operation on SIMATIC S5	53
6.3	Operation on SIMATIC S7	54
6.4	Exchanging data using internode communication function	56
6.5	SIMATIC HMI (Human-Machine Interface)	59
6.6	Operation on external master systems	61

7	Diagnostics and Troubleshooting.....	63
7.1	Diagnostics using LED display	63
7.2	Diagnostics using alarm number (alarms and faults)	64
7.3	Diagnostics using diagnostic parameter	65
7.3.1	Identification of the communications components	65
7.3.2	Standard diagnostics	66
7.3.3	Special diagnostics for start-up personnel.....	68
8	Appendix	69
8.1	Technical data.....	69
8.2	EMC information	69
9	Glossary	71

1 Description of MICROMASTER PROFIBUS Optional Board

The function of the PROFIBUS-DP communication board (PROFIBUS optional board) is to provide a PROFIBUS-DP-based link between drives of the MICROMASTER 4 product range and higher-level automation systems.

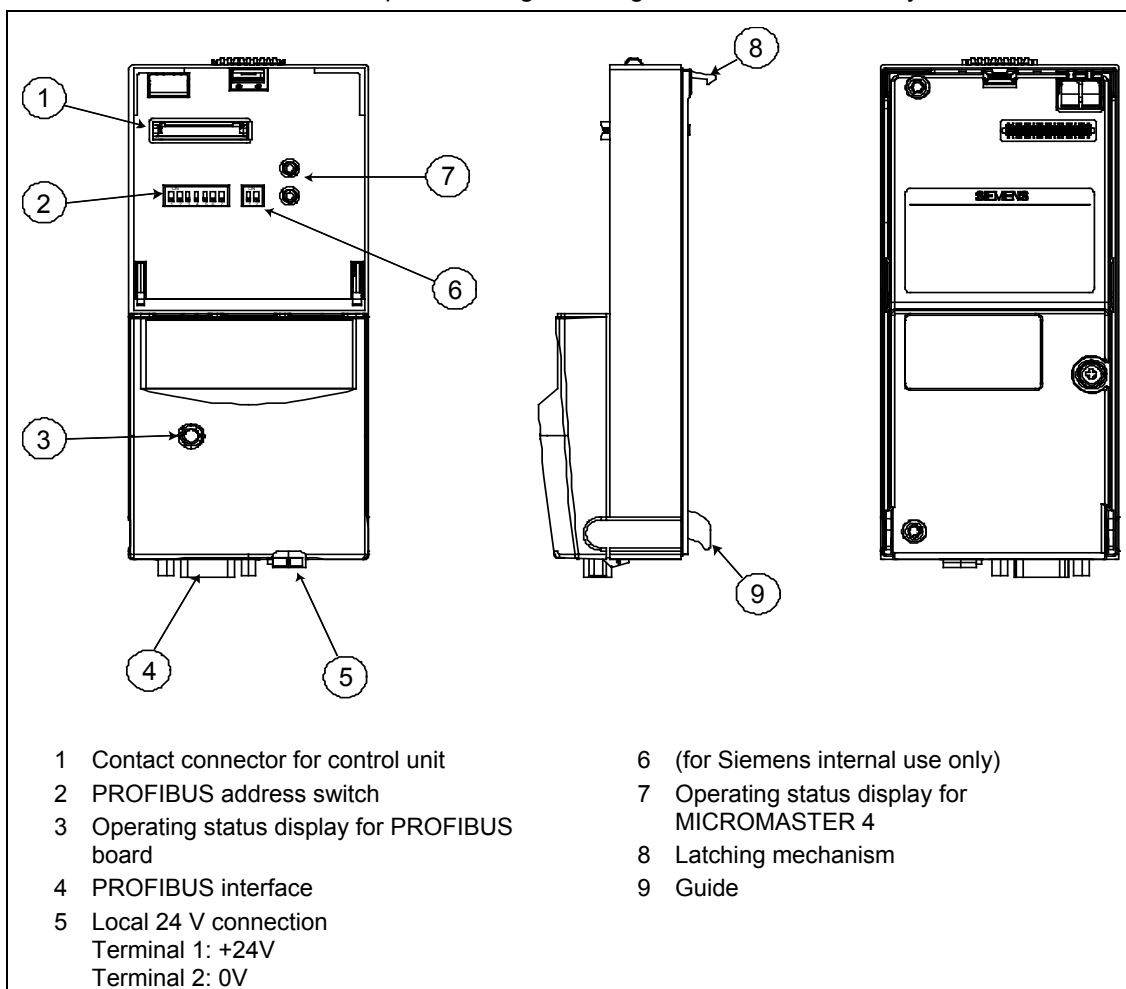

Fig. 1-1 View of communication board

Technical data

To display information about the current operating state, the communication board has a 3-color LED (green, orange, red).

The communication board voltage is supplied via the inverter system connector.

Alternatively, an external 24 V connection can supply the voltage for the PROFIBUS optional board and inverter electronics.

The board is connected to the PROFIBUS system via bus connector complying with the PROFIBUS standard. All connections to this RS485 interface are short-circuit-proof and isolated.

The PROFIBUS optional board supports baud rates of 9.6 kbaud to 12 MBaud. Fiber optics can be connected using Optical Link Plugs (OLPs) or Optical Link Modules (OLMs).

Functionality

- Cyclical process data exchange (PZD) in accordance with PROFIdrive Profile, version 2.0 or version 3.0
- Parameter accessing:
 - Cyclical accessing of parameters (PKW) in accordance with PROFIdrive Profile version 2.0
 - or
 - acyclical accessing of parameters (data block 47) in accordance with PROFIdrive Profile version 3.0
- Acyclical accessing of parameters (data block 100/data block 47) for the purpose of exchanging parameter values with a SIMATIC S7 CPU (Drive ES SIMATIC function block package)
- Acyclical accessing of parameters for SIMATIC HMI or start up tool STARTER.
- Support of PROFIBUS control commands SYNC and FREEZE for synchronized data transfer between the master and several slaves
- Internode communication for direct exchange of process data between PROFIBUS slaves (only in conjunction with SIMATIC S7 at the present time).

2 General Definition of PROFIBUS-DP

Definition

PROFIBUS is an international, open field bus standard which is used widely in the fields of production and process automation. The bus is guaranteed brand-neutral and open by virtue of its compliance with international standard IEC 61158.

PROFIBUS-DP is a PROFIBUS communication profile optimized for high-speed, time-critical data transmission at field level using low-cost connections.

PROFIBUS-DP is a suitable substitute for conventional, parallel 24 V signal transmission systems in manufacturing, as well as for analog 4..20 mA signal transmission systems in process automation.

PROFIBUS is a multi-master system, in other words, it is a bus on which several automation, engineering or visualization systems can operate together with the associated distributed field devices. In the context of PROFIBUS, master and slave devices are defined as follows:

- Master devices control data traffic on the bus; they are also referred to as "active" nodes. A master may transmit messages without prior receipt of an external request provided that it has bus access authorization (token). There are two classes of master:
 - ◆ Class 1 master:
These are central automation stations (e.g. SIMATIC S5, S7 and SIMADYN D) which exchange information with slaves in predefined message cycles.
 - ◆ Class 2 master:
These are programming, configuring or operator control and monitoring systems that are used to configure or start up or monitor the plant in operation.
- Slave devices are field devices such as drives (MICROMASTER 4) , I/O devices and valves. They never receive bus access authorization, i.e. they may only acknowledge received messages or return information to a master on request. Slave devices are also referred to as "passive" nodes.

RS-485 transmission system

Criteria such as high transmission speed and simple, low-cost installation are of critical importance in the selection of the transmission system. The RS-485 requires a screened copper cable with twisted-pair wires.

The transmission speed can be selected within the 9.6 kbaud to 12 MBaud range. It is set globally for all devices on the bus during system start-up.

General information about RS-485 transmission installation

All devices are connected in a bus structure (line). Up to 32 nodes (master or slaves) can be interconnected within one segment. The bus is terminated by an active bus terminator at the beginning and end of each segment. To ensure fault-free operation, both bus terminators must have a voltage supply at all times. The bus terminators can normally be activated either in the devices themselves or on the bus termination connectors.

To accommodate more than 32 nodes or increase the scope of the network, repeaters (cable amplifiers) can be installed to link the individual bus segments.

Fiber-optic transmission system

PROFIBUS can be implemented by means of fiber optics for installation in environments susceptible to high levels of radiated emission, where electrical isolation is essential or to increase the bus range with high transmission speeds. Various fiber types are available to suit different range, price and application requirements.

The following table shows a list of suitable fiber types:

Fiber type	Properties
Multimode glass fiber	Medium range, 2-3 km
Monomode glass fiber	Long range, > 15 km
Plastic fiber	Short range, < 80 m
PCS/HCS fiber	Short range, approx. 500 m

PROFIBUS segments implemented by fiber optics are configured either as a star or ring structure. Couplers between RS-485 and fiber optic transmission systems are also available, allowing the two types of system to be deployed alternately as required within the same installation.

Bus accessing mode

PROFIBUS operates according to the token passing principle, i.e. the active stations (masters) receive transmit authorization in a logical ring for a defined time window. Within this window, the master can communicate with other masters or exchange data with the relevant slaves in a subordinate master-slave process.

PROFIBUS-DP primarily utilizes the master-slave process for this purpose; in most cases, it exchanges data with drives such as MICROMASTER 4 cyclically.

Data exchange via PROFIBUS-DP

Data can be exchanged between the higher-level systems (e.g. SIMATIC, SIMADYN D, PC/PGs) and the drives very quickly via the PROFIBUS-DP. Drives are always accessed according to the master-slave principle. Drives are always slave nodes. Each slave can be identified by its unique address on the bus (MAC).

Standards, guidelines and other information

All the standards and guidelines listed below can be obtained from the PROFIBUS User Organisation (PNO), www.profibus.com.

- PROFIBUS
"Short Technical Description" September 1999
Order No. 4.001
- PROFIBUS Specification (FMS, DP, PA)
All normative definitions in relation to the PROFIBUS specification according to EN 50170 Vol. 2.0 (version 1.0)
Order No. 0.042 (English)
- PROFIBUS-DP Expansions
includes acyclical communication functions with PROFIBUS-DP
"Extensions to EN 50170"
EN 50 170 Vol. 2 (version 2.0)
Order No. 2.082 (English)
- PROFIBUS Technical Guideline
"Installation Guidelines for PROFIBUS-DP/FMS" September 1998
Order No. 2.111
- PROFIBUS Guideline
"Connections for PROFIBUS" February 2000
Version 1.0
Order No. 2.141
- PROFIBUS Guideline
"Optical Transmission System for PROFIBUS" July 1999 (Draft)
Version 2.0
Order No. 2.021
- PROFIdrive Profile Version 2.0:
"Profile for Variable-Speed Drives" September 1997
PNO - PROFIBUS Profile - Order No. 3.071 (German) / 3.072 (English)
- PROFIdrive Profile Version 3.0:
" PROFIdrive Profile Drives" September 2000 (Draft)
PNO - PROFIBUS Profile - Order No. 3.172 (English)
- International field bus standard IEC 61158
(from start of 2000: PROFIBUS as one of **eight solutions** in the IEC 61158*)

A small historical overview on the topic of the PROFIBUS standard:
Up to the end of the Nineties: DIN 19245*)
From the end of the Nineties: as one of **five solutions** in the EN 50170*)

*) Source: NettedAutomation

3 Communication with MICROMASTER 4 via PROFIBUS-DP

The following illustration shows an overview of the PROFIBUS-DP communication functions implemented on MICROMASTER 4:

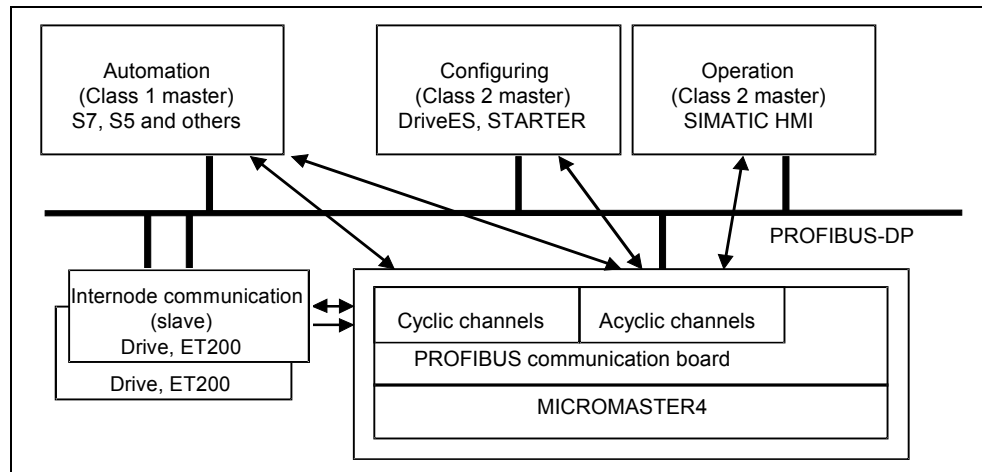

Fig. 3-1 PROFIBUS-DP data channels on MICROMASTER 4

3.1 Cyclical data of MICROMASTER 4 via PROFIBUS-DP

The MICROMASTER 4 is controlled via the cyclical PROFIBUS-DP channel. This same channel can be used to exchange parameters.

The structure of user data for the cyclical channel is defined in the PROFIdrive Profile, version 2.0, and referred to as the Parameter Process data Object (PPO).

The PROFIdrive Profile defines for the drives the user data structure with which a master can access the drive slaves using the cyclical data communication method.

3.1.1 User data structure as defined in PROFIdrive Profile 2.0 and 3.0

User data structure according to PPOs

The user data structure for cyclical data traffic is divided into two areas which can be transmitted in each telegram:

Process data area (PZD), i.e. control words and setpoints, or status information and actual values

Parameter area (PKW) for reading/writing parameter values, e.g. reading out faults, or reading out information about the properties of a parameter such as, for example, min/max limits, etc.

With which PPO type (see next page) the inverter is addressed by the PROFIBUS-DP master can be defined in the configuration data for the master when the bus system is started up. Which type of PPO is selected depends on the function of the drive in the automation network. Process data are always transferred. They are processed as top priority in the shortest time slices in the drive.

Process data are used to control the drive in the automation network, e.g. On/Off commands, setpoint inputs, etc.

The parameter area enables the user to access all parameters stored in the inverter via the bus system. For example, to read out detailed diagnostic information, faults messages, etc.

The telegrams for cyclic data transmission thus have the following basic structure:

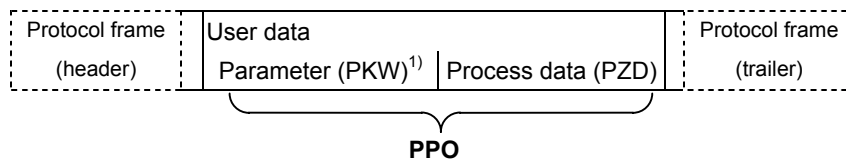

1) PKW: Parameter identifier value

Five types of PPO are defined according to PROFIdrive Profile, version 2.0:

- User data without parameter area, with two or six words of process data or
- User data with parameter area, with two, six or ten words of process data.

	PKW				PZD									
	PKE	IND	PWE		PZD1 STW1 ZSW1	PZD2 HSW HIW	PZD3	PZD4	PZD5	PZD6	PZD7	PZD8	PZD9	PZD10
	1 st word	2 nd word	3 rd word	4 th word	1 st word	2 nd word	3 rd word	4 th word	5 th word	6 th word	7 th word	8 th word	9 th word	10 th word
PPO1														
PPO2														
PPO3														
PPO4														
PPO5														

PKW: Parameter identifier value

STW: Control word 1

PZD: Process data

ZSW: Status word 1

PKE: Parameter identifier

HSW: Main setpoint

IND: Index

HIW: Main actual value

PWE: Parameter value

Fig. 3-2 Parameter process data object (PPO types)

NOTE

MICROMASTER 420 supports only PPO1 and PPO3 (shaded areas).

MICROMASTER 440/430 supports PPO1, PPO2, PPO3 and PPO4 (underscored with dotted line).

The user data structure has been subdivided into the PKW and PZD areas in order to satisfy different functional requirements of the communication system.

Parameter data area (PKW)

The PKW (parameter identifier value) telegram section can be used to monitor and/or change any parameter in the inverter. The request/response identifier mechanisms required to do this are described in Section 3.4 "PKW mechanism".

Process data area (PZD)

Control words and setpoints (requests: Master → inverter) and status words and actual values (responses: Inverter → master) can be transmitted in the process data area.

The transferred process data do not take effect until the bits used in the control words, setpoints, status words and actual values have been routed in the inverter as described in Section "Process data connections" of the reference manual.

Extended configuration for the MICROMASTER 420/440/430

In addition to the PPO types, cyclical data can also be configured optionally.

Up to four process data words, with a different number of setpoints and actual values if desired, can be configured on the MICROMASTER 420, and up to 8 process data words can be configured on the MICROMASTER 440/430. The areas of consistency can be set flexibly.

A parameter area (PKW) can be configured irrespective of the number of process data.

PKW				PZD									
PKE	IND	PWE		PZD1 STW1 ZSW1	PZD2 HSW HIW	PZD3	PZD4	PZD5	PZD6	PZD7	PZD8	PZD9	PZD10
1 st word	2 nd word	3 rd word	4 th word	1 st word	2 nd word	3 rd word	4 th word	5 th word	6 th word	7 th word	8 th word	9 th word	10 th word
420:													
Max.													
Max.													
440/ 430:													
Max.													
Max.													

- PKW: Parameter identifier value IND: Index ZSW: Status word 1
- PZD: Process data PWE: Parameter value HSW: Main setpoint
- PKE: Parameter identifier STW: Control word 1 HIW: Main actual value

Fig. 3-3 Parameter process data object (optional configuration for MICROMASTER 420/440/430)

Default assignment of PZD3/4

Assignment for MICROMASTER 420 and 440/430 is the same.

DP Master → MICROMASTER 4:

PZD3: No default assignment

PZD4: No default assignment

PZD3 and PZD4 can be freely assigned and interconnected by means of BICO parameters.

MICROMASTER 4 → DP Master:

PZD3: No default assignment

PZD4: Status word 2, r0053

Planning the extended configuration for MICROMASTER 420/440/430

The GSD can be used to choose between the configurations shown in Fig. 3-3 (in addition to PPO types).

Planning the extended configuration for MICROMASTER 420 and 440/430

This type of configuration is only possible with Drive ES.

3.1.2 MICROMASTER 4 reaction time

The reaction time of MICROMASTER 4 with respect to PZD is approximately 20 milliseconds.

This represents the period of time between "setpoint arrives at DP slave" and "updated (and referencing) actual value is made available on PROFIBUS-DP".

The reaction time of the MICROMASTER 4 with respect to a parameter modification (PKW) is approximately 50 milliseconds.

3.2 Acyclic data transmission

Extended PROFIBUS-DP functions (DPV1)

The PROFIBUS-DP extensions DPV1 include the definition of an acyclic data exchange which can take place in parallel to cyclical data transmissions.

Acyclic data transfer mode allows

- large quantities of user data (up to 240 bytes) to be exchanged
- simultaneous accessing by other PROFIBUS masters (class 2 master, e.g. start-up tool)
- omission of I/O address in the SIMATIC and reduction of bus cycle time through relocation of PKW area from the cyclical to the acyclical transmission channel

Conversion of extended PROFIBUS-DP functionality

The different masters, or different modes of data exchange, are represented by appropriate channels in MICROMASTER 4:

- Cyclical data exchange with one class 1 master
Use of DATA-EXCHANGE and PPO types according to PROFIdrive Profile.
- Acyclical data exchange with the same class 1 master
Use of DPV1 functions READ and WRITE
The content of the transferred data block corresponds in this case to the structure of the parameter area (PKW) as defined in the USS specification (with data block 100)
or
the structure of the acyclical parameter channel according to PROFIdrive Profile, version 3.0 (with data block 47).
- Acyclical data exchange using a SIEMENS start-up tool (class 2 master)
The start-up tool can acyclically access parameter and process data in the inverter.
- Acyclical data exchange with a SIMATIC HMI (second class 2 master)
The SIMATIC HMI can acyclically access parameters in the inverter.
- Instead of a SIEMENS start-up tool or SIMATIC HMI, an external master (class 2 master) as defined in the acyclical parameter channel according to PROFIdrive Profile version 3.0 (with data block 47) can access the inverter.

3.3 Control and status words

The control and status words comply with the specifications for PROFIdrive Profile, version 2.0 or 3.0, for "Closed-loop speed control mode".

3.3.1 Control word 1

Control word 1 (bits 0-10 as per PROFIdrive Profile, bits 11-15 specific to MICROMASTER 4)

Table 3-1 Control word 1 bit assignments

Bit	Value	Meaning	Remarks
0	1	ON	Sets the inverter to the "Ready to run" state, direction of rotation must be defined via bit 11
	0	OFF1	Shutdown, deceleration along RFG ramp, pulse disable when $f < f_{min}$
1	1	Operating condition	-
	0	OFF2	Instantaneous pulse disable, drive coasts to a standstill
2	1	Operating condition	-
	0	OFF3	Rapid stop: Shutdown at fastest possible acceleration rate
3	1	Enable operation	Closed-loop control and inverter pulses are enabled
	0	Disable operation	Closed-loop control and inverter pulses are disabled
4	1	Operating condition	-
	0	Disable ramp-function generator	Output of RFG is set to 0 (fastest possible braking operation), inverter remains in the ON state
5	1	Enable RFG	-
	0	Stop RFG	Setpoint currently supplied by the RFG is "frozen"
6	1	Enable setpoint	Value selected at the RFG input is activated.
	0	Disable setpoint	Value selected at the RFG input is set to 0.
7	1	Acknowledge fault	Fault is acknowledged with a positive edge, inverter then switches to "starting lockout" state
	0	No meaning	
8	1	CW inching	
	0		
9	1	CCW inching	
	0		
10	1	Setpoints valid	Master transfers valid setpoints
	0	Setpoints invalid	
11	1	Setpoint inverted	Motor rotates CCW in response to positive setpoint
	0	Setpoint is not inverted	Motor rotates CW in response to positive setpoint
12	-	-	Not used
13	1	Motor potentiometer UP	
	0		
14	1	Motor potentiometer DOWN	
	0		
15	-	-Local control (BOP/AOP)	Local control active
	-	Remote control	Remote control active

Information about Bit 15:

Supplement for the MICROMASTER 420:

In the control word1 the Bit 15 is the switchable local/remote control in the MICROMASTER 420 (SW-status > 1.05). This bit switches the parameter P719 between Index 0 and Index 1. In the factory setting P719 is Index 0 to 0 = optionally programmable BICO parameter and Index 1 to 11= BOP and MOP-target value. This means that when the local operation = Index 0 the parameters for the source code can be set via P700 and the parameters for the selection of the frequency target value can be set via P1000. For remote operation the Index 1 is active and it is switched to operation via the basic operation field (BOP).

Supplement for the MICROMASTER 440/430:

In MICROMASTER 440/430 it is possible, via the function local/remote control, to change between the command record (CDS) 0 and 1 of the control word 1 Bit 15. This results in a switching of the command records. The command record 0 is active in local operation and the command record 1 for remote operation. Now in both command records the application-specific parameters for the command and target value sources can be set.

An example:

In the remote control operating mode the commands and target values come from a superior control system to the inverter by means of a Profibus. By switching to local operation, the command and target value source is switched and operation is now performed locally on the system by means of digital inputs and the analog target values.

Local operation = Command record 0: In this case the command code of the terminal strip P700 Index 0 = 2 and the frequency target value is the analog target value P1000 Index 0 = 2.

Remote operation = Command record 1: In this case the command code corresponds with the control word (word 0) received from the Profibus P700 Index 01= 6 and the frequency target value corresponds with the control word (word 1) received from the Profibus P1000 Index 0 = 6.

Because P719 is also included in the command record it is compatible to the solution for MM420. By switching the command record the active index of every parameter which is included in the command record is switched.



Warning

The control word of the MICROMASTER 4 is different from that of the MICROMASTER3!

3.3.2 Default assignment control word 2

The control word 2 is assigned as a default as follows. This can be changed by using BICO.

Table 3-2 Assignment control word 2

Bit	Value	description
0	1	Fixed frequency Bit 0
	0	
1	1	Fixed frequency Bit 1
	0	
2	1	Fixed frequency Bit 2
	0	
3	1	MICROMASTER 4, specific to model
	0	
4	1	MICROMASTER 4, specific to model
	0	
5	1	MICROMASTER 4, specific to model
	0	
6	1	MICROMASTER 4, specific to model
	0	
7	1	MICROMASTER 4, specific to model
	0	
8	1	MICROMASTER 4, specific to model
	0	
9	1	MICROMASTER 4, specific to model
	0	
10	1	MICROMASTER 4, specific to model
	0	
11	1	MICROMASTER 4, specific to model
	0	
12	1	MICROMASTER 4, specific to model
	0	
13	1	MICROMASTER 4, specific to model
	0	
14	1	MICROMASTER 4, specific to model
	0	
15	1	MICROMASTER 4, specific to model
	0	

As standard, the 2nd control word is received as the 4th word of the cyclic user data (PZD4).

3.3.3 Status word 1

Status word 1 (bits 0-10 as per PROFIdrive Profile, bits 11-15 specific to MICROMASTER 4)

Table 3-3 Bit assignments, status word 1

Bit	Value	Meaning	Remarks
0	1	Ready for ON	Power supply switched on, electronics initialized, pulses disabled
	0	Not ready for ON	
1	1	Ready to run	(see control word bit 0) Converter is switched on (ON command is applied), no fault is active, inverter can start when "Enable operation" command is issued. Causes: No ON command, fault, OFF2 or OFF3 command, starting lockout
	0	Not ready to run	
2	1	Operation enabled	See control word, bit 3
	0	Operation disabled	
3	1	Fault is active	Fault, see fault parameter r0947 etc. Drive is faulty and thus inoperative, switches to starting lockout state after successful correction and acknowledgement of fault.
	0	-	
4	1	-	See control word, bit 1
	0	OFF2 command applied	
5	1	-	See control word, bit 2
	0	OFF3 command applied	
6	1	Starting lockout	Drive can be restarted only by OFF1 followed by ON
	0	No starting lockout	
7	1	Alarm is active	Alarm, see alarm parameter r2110. Drive still in operation.
	0	-	
8	1	No setpoint/act.val. deviation	Setpoint/actual value deviation within tolerance range
	0	Setpoint/act.val. deviation	
9	1	Master control requested	The master is being requested to accept status as master control. The master is not currently the master control.
	0	Local operation	
10	1	f reached	Converter output frequency is higher or equal to the maximum frequency
	0	f not reached	
11	1	-	
	0	Alarm: Motor at current limit	
12	1	-	Signal can be used to control a holding brake.
	0	Motor holding brake	
13	1	-	Motor data indicate overload condition
	0	Motor overload	
14	1	CW rotation	
	0	CCW rotation	
15	1	-	e.g. current or temperature
	0	Converter overload	

3.3.4 Status word 2

Status word 2 has the following default assignment: This can be modified using BICO.

Table 3-4 Assignment, status word 2

Bit	Value	Binary signal	Description
0	1		DC current brake active
	0		
1	1		
	0		Drive inverter frequency < Shutdown limit
2	1		
	0		
3	1		Current \geq Limit
	0		
4	1		Actual frequency > Reference frequency
	0		
5	1		Actual frequency < Reference frequency
	0		
6	1		Actual frequency \geq Setpoint
	0		
7	1		Voltage < Threshold value
	0		
8	1		Voltage > Threshold value
	0		
9	1		Opposite direction
	0		
10	1		PI frequency < Threshold value
	0		
11	1		PI saturation
	0		
12	1		MICROMASTER 4, model-specific
	0		
13	1		MICROMASTER 4, model-specific
	0		
14	1		MICROMASTER 4, model-specific
	0		
15	1		MICROMASTER 4, model-specific
	0		

The 2nd status word is sent from the drive inverter, as standard, as 4th word of the cyclic user data (PZD4).

3.4 PKW mechanism for processing parameters

Parameter area (PKW)

Using the PKW mechanism you can process and monitor parameters (write/read) as described below:

Precondition:

PPO type 1 on MICROMASTER 4 in accordance with PROFIdrive Profile version 2.0

or

use of acyclical channel in conjunction with data block 100

The parameter area includes at least 4 words.

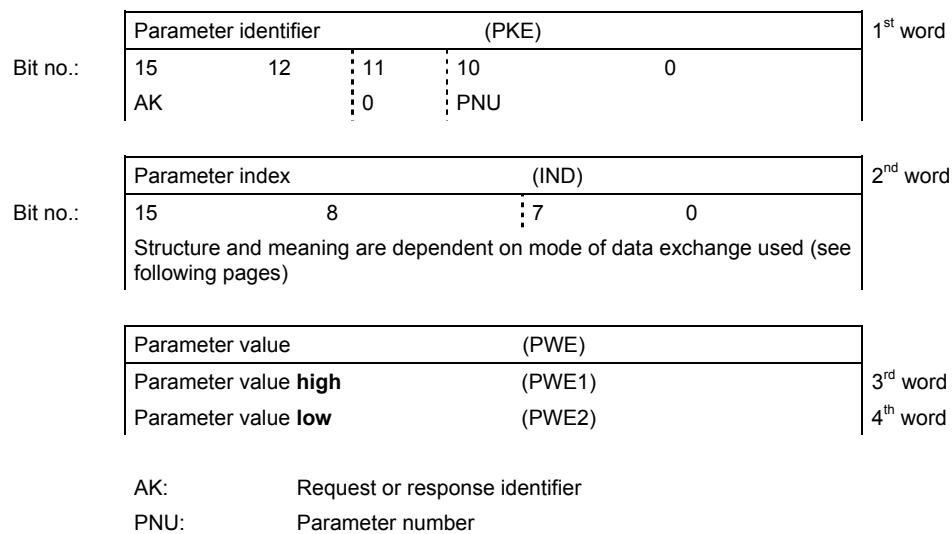

Fig. 3-4 Structure of parameter area (PKW)

Parameter identifier (PKE), 1st word

The parameter identifier (PKE) is always a 16-bit value.

Bits 0 to 10 (PNU) contain the number of the relevant parameter.

Bit 11 is reserved.

Bits 12 to 15 (AK) contain the request or the response identifier.

The meaning of the request identifier for request telegrams (master → inverter) is shown in **Table 3-5**. Request identifiers 11 to 14 are specific to MICROMASTER and not defined in the PROFIdrive Profile.

The meaning of the response identifier for response telegrams (inverter → master) is shown in

Table 3-6. The request identifier will determine which response identifiers are possible. If the response identifier is 7 (cannot process request), then one of the fault numbers listed in **Table 3-7** will be stored in parameter value 2 (PWE2).

Table 3-5 Request identifier (master -> inverter)

Request identifier	Meaning	Response identifier	
		positive	negative
0	No request	0	7 / 8
1	Request parameter value	1 / 2	↑
2	Modify parameter value (word)	1	
3	Modify parameter value (double word)	2	
4	Request descriptive element 1	3	
6	Request parameter value (array) 1	4 / 5	
7	Modify parameter value (array, word) 2	4	
8	Modify parameter value (array, double word) 2	5	
9	Request number of array elements	6	
11	Modify parameter value (array, double word) and store in EEPROM 2	5	
12	Modify parameter value (array, word) and store in EEPROM 2	4	
13	Modify parameter value (double word) and store in EEPROM	2	↓
14	Modify parameter value (word) and store in EEPROM	1	7 / 8

Table 3-6 Response identifier (inverter -> master)

Response identifier	Meaning
0	No response
1	Transfer parameter value (word)
2	Transfer parameter value (double word)
3	Transfer descriptive element 1
4	Transfer parameter value (array word) 2
5	Transfer parameter value (array double word) 2
6	Transfer number of array elements
7	Cannot process request (with error number)
8	No master control status for PKW interface

1 The desired element of the parameter description is specified in IND (2nd word)

2 The desired element of the indexed parameter is specified in IND (2nd word)

Table 3-7 Fault numbers for "Cannot process request" response

No.	Meaning	
0	Illegal parameter number (PNU)	Parameter does not exist
1	Parameter value cannot be modified	Parameter is a read-only parameter
2	Minimum/maximum not reached/exceeded	-
3	Faulty subindex	-
4	No array	Single parameter has been accessed with array request and subindex > 0
5	Incorrect data type	Mix-up between word and double word
6	Setting not allowed (resetting only)	-
7	Descriptive element cannot be modified	Description can never be modified with MICROMASTER 4
11	No status as master control	Modification request without status as master control (see P0927)
12	Key word missing	-
17	Request cannot be processed due to operating state	Current inverter status is not compatible with the received request
101	Parameter number currently deactivated	Dependent on inverter status
102	Channel not wide enough	Communication channel too small for response
104	Illegal parameter value	Parameter permits only certain values
106	Request not implemented	After request identifier 5, 10, 15
200/ 201	Modified minimum/maximum not reached/exceeded	Minimum/maximum can be further limited in operation
204	Available access authorization does not cover modification of parameters	-

Parameter index (IND) 2nd word

Important NOTE

Assignments of index (IND) differ in the PPOs and on the acyclical channel (data block 100):

Structure of IND for cyclical communication via PPOs

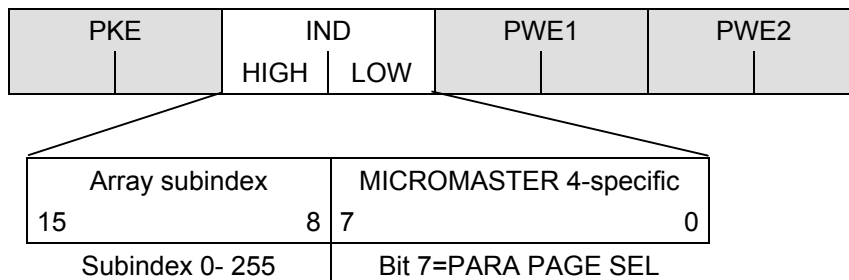

The array subindex (referred to simply as "subindex" in the PROFIdrive Profile) is an 8-bit value which is transferred in the high-order byte (bits 8 to 15) of the parameter index (IND) when data are transferred cyclically via PPOs. The low-order byte (bits 0 to 7) is not defined in PROFIdrive Profile version 2.0. The low-order byte of the parameter index is used on MICROMASTER 4 to be able to address additional parameters with a number of >1999.

Example coding for parameter no. in PKE and IND for "P2016, Index 3".

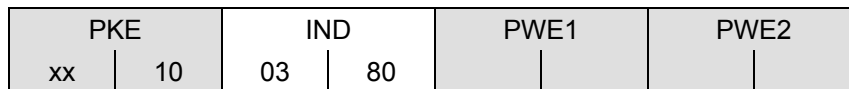

Structure of IND for acyclical communication

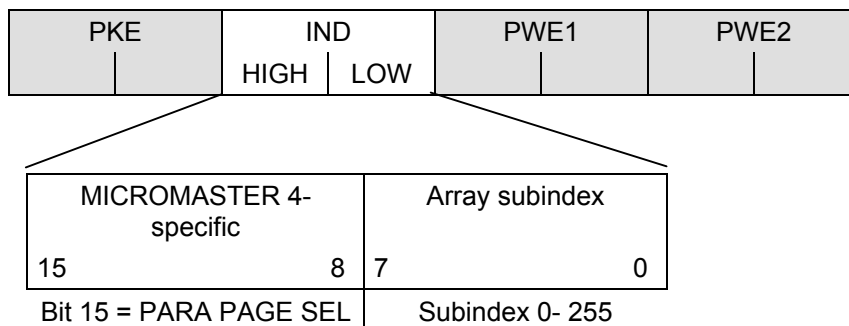

The array subindex is an 8-bit value which is always transferred in the low-order byte (bits 0 to 7) of the parameter index (IND) in acyclical data exchange mode. The Parameter Page Selection task for additional parameters is performed in this case by the high-order byte (bits 8 to 15) of the parameter index. This structure conforms to the USS specification.

Example coding for parameter no. in PKE and IND for "P2016, Index 3".

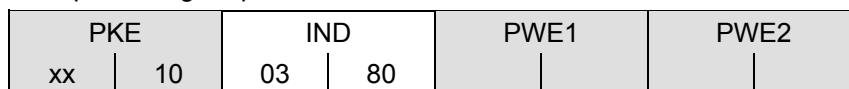

Function of the subindex in IND

Subindex = 0 .. 254

If the subindex is transferred with values between 0 and 254 in a request, the relevant parameter index is transferred in the case of an indexed parameter. For the meaning of the individual indices of a parameter, please refer to the "Parameter List" in the inverter operating instructions.

In the case of a descriptive element, the number of the required element is transferred. The meaning of descriptive elements can be found in the PROFIdrive Profile, version 2.0.

Subindex = 255

A value of 255 for the array subindex is a MICROMASTER 4-specific, special function. If the array index is transferred with 255, all the indices of an indexed parameter are transmitted simultaneously in one data block.

The function is meaningful only for acyclical data exchange mode. The structure of the transferred data block complies with the USS specification. The maximum data block size is 206 bytes.

Function of PARA PAGE SEL

The bit for parameter page selection functions as follows:

If it is set to 1, an offset of 2000 is applied in MICROMASTER 4 to the parameter number (PNU) transferred in the PKW request before it is passed on.

Parameter name (acc. to Parameter List)	Corresponding mode of parameter addressing via PROFIBUS		
	PNU [decimal]	PNU [Hex.]	Bit 15: PARA PAGE SEL
P0000 - P1999	0 – 1999	0 - 7CF	= 0
P2000 - P3999	0 – 1999	0 - 7CF	= 1

Parameter value (PWE) 3rd and 4th word

The parameter value (PWE) is always transmitted as a double word (32-bit). Only one parameter value at a time can be transferred in a PPO telegram.

A 32-bit parameter value comprises PWE1 (high-order word, 3rd word) and PWE2 (low-order word, 4th word).

A 16-bit parameter value is transferred in PWE2 (low-order word, 4th word). PWE1 (high-order word, 3rd word) must be set to 0 on the PROFIBUS-DP master in this case.

Rules for processing requests/responses

- A request or a response can only ever refer to one parameter.
- The master must repeat a request continuously until it has received the appropriate response.
- The master detects the response to a request it has sent by
 - ◆ evaluating the response identifier,
 - ◆ evaluating the parameter number PNU,
 - ◆ evaluating the parameter index IND if necessary, or
 - ◆ evaluating the parameter value PWE if necessary.
- The complete request must be sent in one telegram. Request telegrams cannot be split. The same applies to responses.
- In the case of response telegrams which contain parameter values, the drive always returns the momentary parameter value when repeating response telegrams.
- If no information needs to be fetched from the PKW interface in cyclical operation (only PZD data are relevant), then the "No request" request telegram must be issued.

3.4.1 Example for using the PKW mechanism via PROFIBUS

Several examples now follow for reading/writing parameters:

Example 1: Reading from parameter P0700 (700 = 2BC (hex))

In order to read a parameter, use task ID 1 "request parameter value". The response ID is either 1 or 2 (individual or double word) or 7 (error).

PROFIBUS => MICROMASTER : 12BC 0000 0000 0000, requests the value of P0700

MICROMASTER => PROFIBUS : 12BC 0000 0000 0002, the response indicates that it is a single word with the value 0002(hex)

Example 2: Reading from parameter P1082 (1082 = 43A (hex))

PROFIBUS => MICROMASTER : 143A 0000 0000 0000, requests the value from P1082

MICROMASTER => PROFIBUS : 243A 0000 4248 0000, the response indicates that it is a double word with the value 4248 0000 (IEEE floating value). The IEEE floating format is as follows: Bit 31 = sign, bit 23 to bit 30 = exponent and bit 0 to bit 22 = mantissa specified by a decimal value: Value = ((-1) to power of sign) x (2 to the power (exponent - 127)) x 1.mantissa.

In this example with sign = 0, exponent = 84 (hex) = 132 and mantissa (1).900000 = [1 + 9/16 + 0/256 + ...] the following is obtained (1) x (32) x (1.5625) = 50.00

Example 3: Reading from parameter P2000 (2000 = 000 (hex) and bit 7 from IND)

In order to read a parameter between 2000 and 3999, you must set the PNU extension in the 2nd word (IND).

PROFIBUS => MICROMASTER : 1000 0080 0000 0000, requests the value from P2000.

MICROMASTER => PROFIBUS : 2000 0080 4248 0000, the response indicates that it is a double word with the value 4248 0000 (IEEE floating value), i.e. 50.00

The data above apply for cyclic communications.

When using non-cyclic communications, bit 15 of IND is used to select parameters from P2000 to P3999; the send and receive data would then be:

PROFIBUS => MICROMASTER : 1000 8000 0000 0000

MICROMASTER => PROFIBUS : 2000 8000 4248 0000

Example 4: Reading parameter P2010, index 1 (2010 = 00A and bit 7 of IND, (as well as here, subindex = 1 for index 1))

This example shows the structure for cyclic communications. In order to read the value of a parameter index, you must define the index in bits 0 to 7 of the 2nd PKW word (IND).

PROFIBUS => MICROMASTER : 100A 0180 0000 0000, requests the value from P2010 index 1.

MICROMASTER => PROFIBUS : 100A 0180 0000 0006, the response indicates that it is a single word with the value 6 (hex).

In this case, task ID 6 could also be used.

Example 5: Changing the value of P1082 to 40.00 [only RAM]

In order to write into a parameter, you must know whether it has a single or double-word parameter value and you must correctly use task ID 2 or 3. In order to find this out, you can initially read the parameter value via PROFIBUS (this information is also contained in the parameter list):

a. Reading a value:

PROFIBUS => MICROMASTER : 143A 0000 0000 0000

MICROMASTER => PROFIBUS : 243A 0000 4248 0000, the response ID 2 indicates that it is a double word. This means that we must use task ID 3: "change parameter value (double word) [RAM only]"

b. Set the parameter to 40.00 (= 4220 0000 (IEEE floating value))

PROFIBUS => MICROMASTER : 343A 0000 4220 0000

MICROMASTER => PROFIBUS : 243A 0000 4220 0000, this confirms that the value was changed.

NOTE:

If modified values are to be saved in the EEPROM, then use task ID 13(=D hex) for double words and task ID 14(=E hex) for words. This should not be permanently and cyclically repeated as otherwise the EEPROM could be damaged.

Example 6: Evaluating an error response

In example 5, it was assumed that the drive inverter is not running. If the correct change telegram is sent with the drive inverter running, the inverter responds with Task Identifier 7 "cannot process request", as P1082 cannot be changed while the inverter is running. The error number is in the parameter value range PKE2.

PROFIBUS => MICROMASTER : 343A 0000 4220 0000

MICROMASTER => PROFIBUS : 743A 0000 0000 0011

The error number is 11 hex = 17 dec "inverter status is not compatible with the received request".

Example 7: Setting P0844 to 722.2 (844 = 34C hex , 722 = 2D2 hex)

This sets digital input 3 to OFF2 (coast stop). P0703 must be set to 99 (activates BiCo parameterization, digital input 3), so that 722.2 becomes the value in P0844.

PROFIBUS => MICROMASTER : 334C 0000 02D2 0002

MICROMASTER => PROFIBUS : 234C 0000 02D2 0002

4 Connection to PROFIBUS-DP

4.1 Installing the PROFIBUS-DP board for Frame Sizes A, B and C

Important NOTE

Make sure that the MICROMASTER 4 inverter is switched off (de-energized) before you install or remove the PROFIBUS-DP communication board.

Installation

Mount the PROFIBUS-DP communication board on the inverter by inserting the two guides at the bottom into the slots provided and push the upper section towards the inverter until the latching mechanism engages.

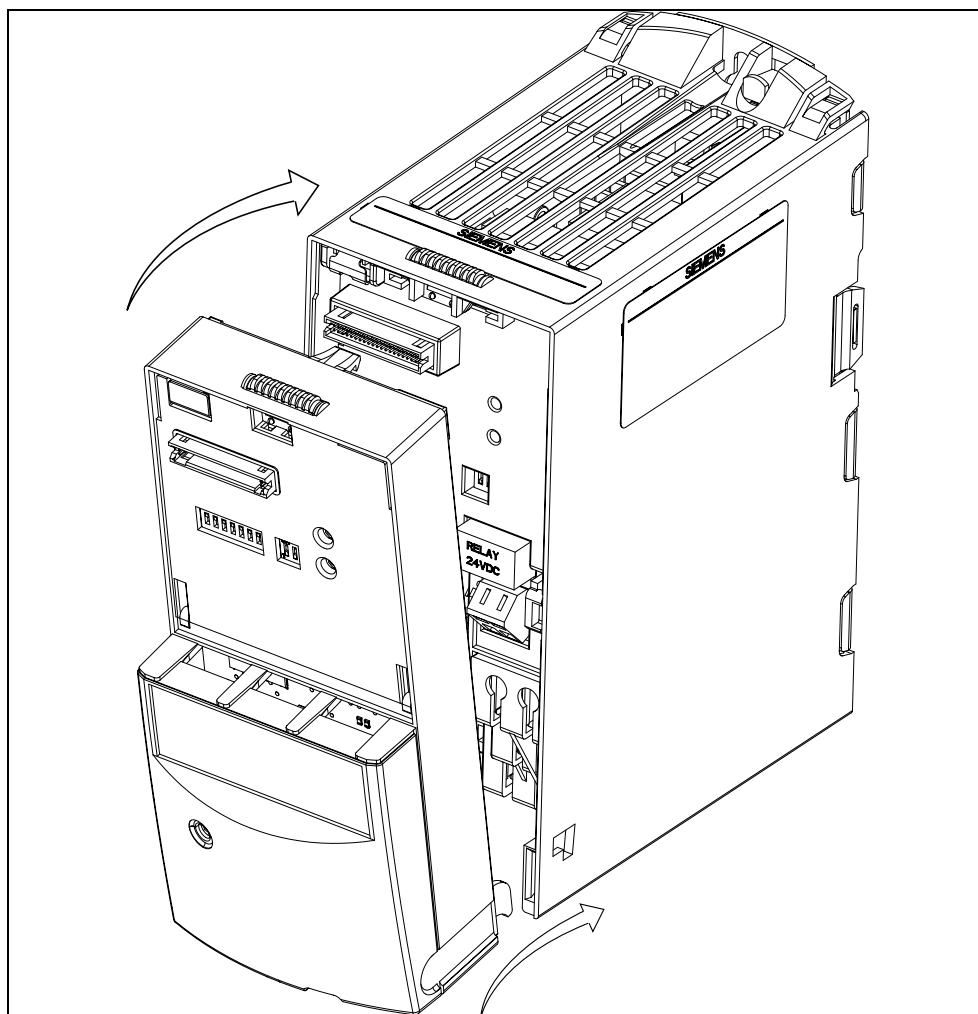

Fig. 4-1 Mounting the communication board on the MICROMASTER 4, frame sizes A, B, C

4.2 Installation of the PROFIBUS-DP component in Frame sizes D, E, F

Important NOTE

Make sure that the MICROMASTER 4 inverter is switched off (de-energized) before you install or remove the PROFIBUS-DP communication board.

Installation

The PROFIBUS-DP communication board is installed in these Frame sizes in **the inverter casing**

To do this both front panels must be removed..

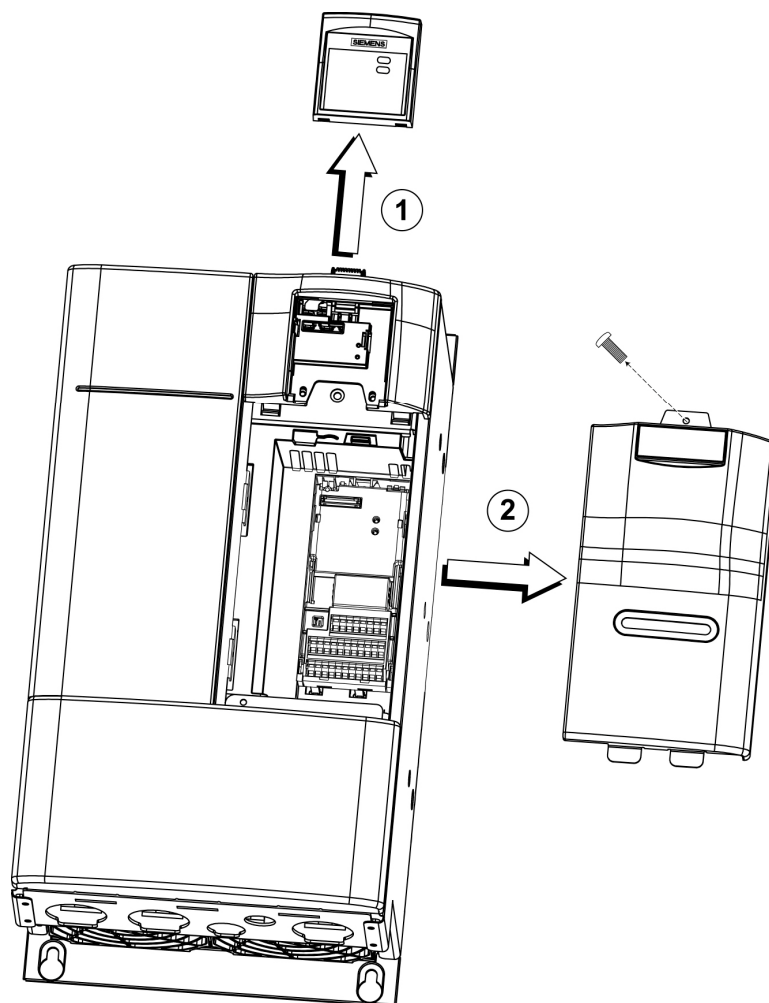

Figure 4-2 Removing the covers of the Frame sizes D, E, F

The following procedure is recommended for the installation of a communication board:

- First feed the bus cable through a suitable cable opening (without plug).
- Then assemble the PROFIBUS plug
- Insert the plug into the communication board
- Remove the Display Interface Module (DIM)
- Snap the communication board into place on the inverter (recessed position).
- Place the Display Interface Module (DIM) onto the installed communication board

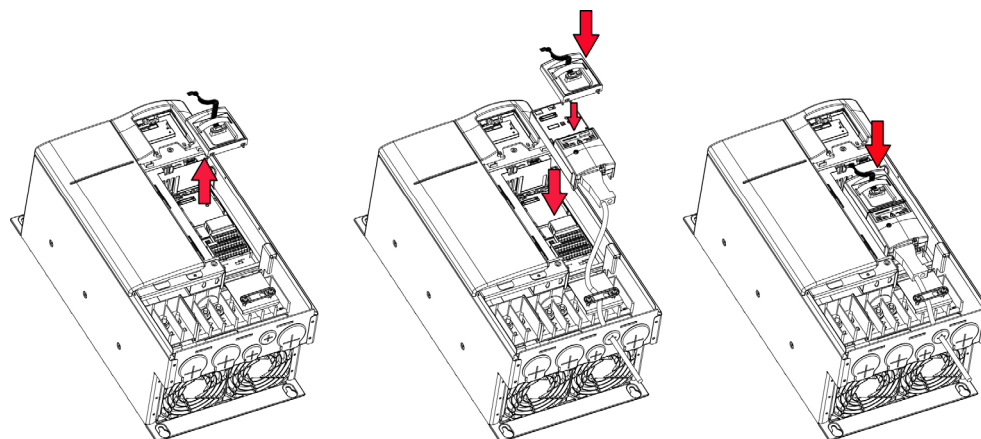

Figure 4-3 Assembly of the communication board in the Frame sizes D, E, F

Then re-attach the panels onto the inverter

4.3 Installation of the PROFIBUS-DP component in Frame sizes FX, GX

Important NOTE

Make sure that the MICROMASTER 4 inverter is switched off (de-energized) before you install or remove the PROFIBUS-DP communication board.

Installation

The PROFIBUS-DP communication board is installed in these Frame sizes in **the inverter casing**

To do this, the front cover must be removed.

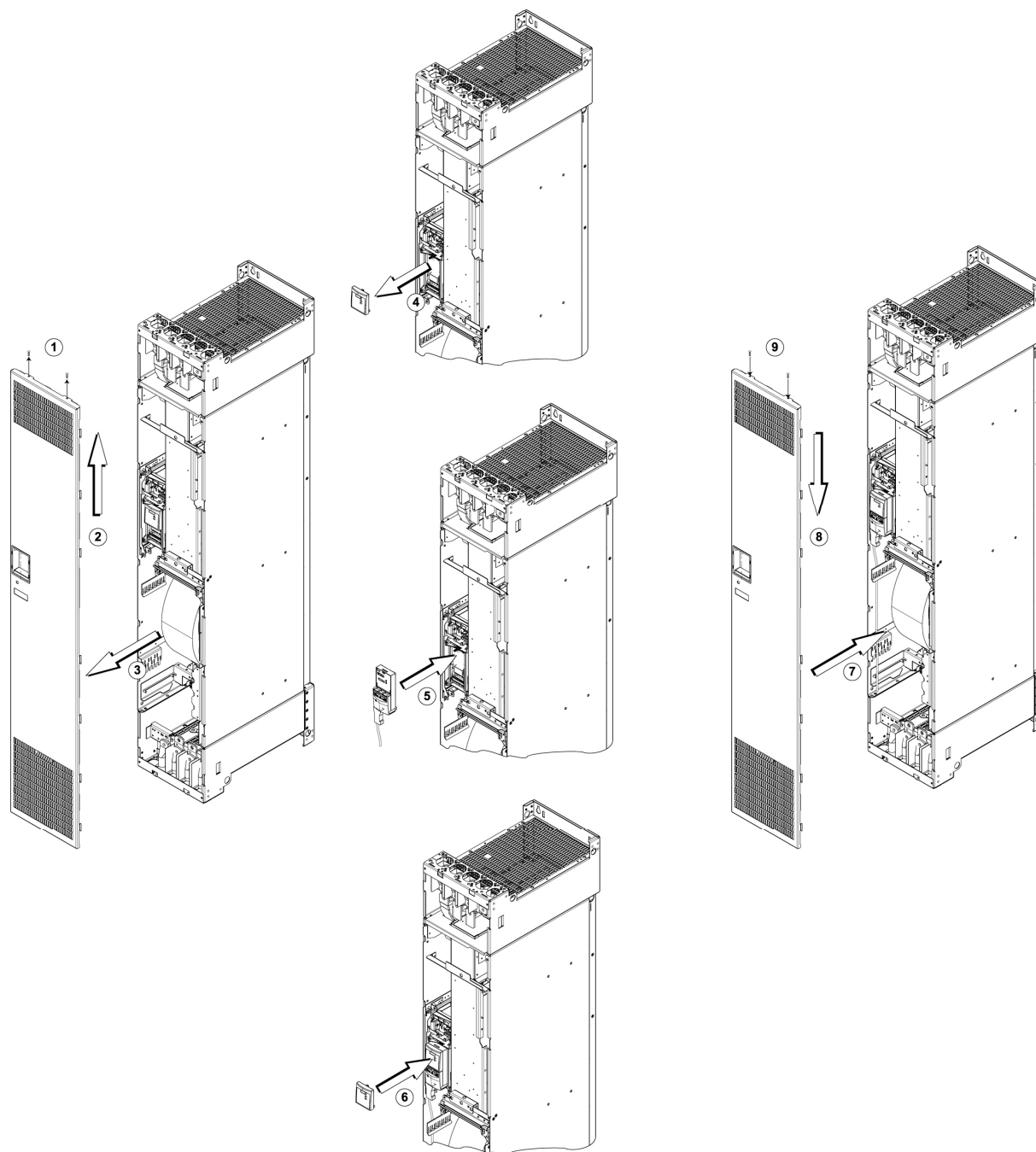

Figure 4-4 Assembly of the communication board in the Frame sizes FX and GX

The installation of the communication board is performed in the same way as for Frame size A (Chap. 4.1), then re-attach the cover onto the inverter.

4.4 PROFIBUS connection on communication board

The PROFIBUS connection is on the bottom edge of the board housing.

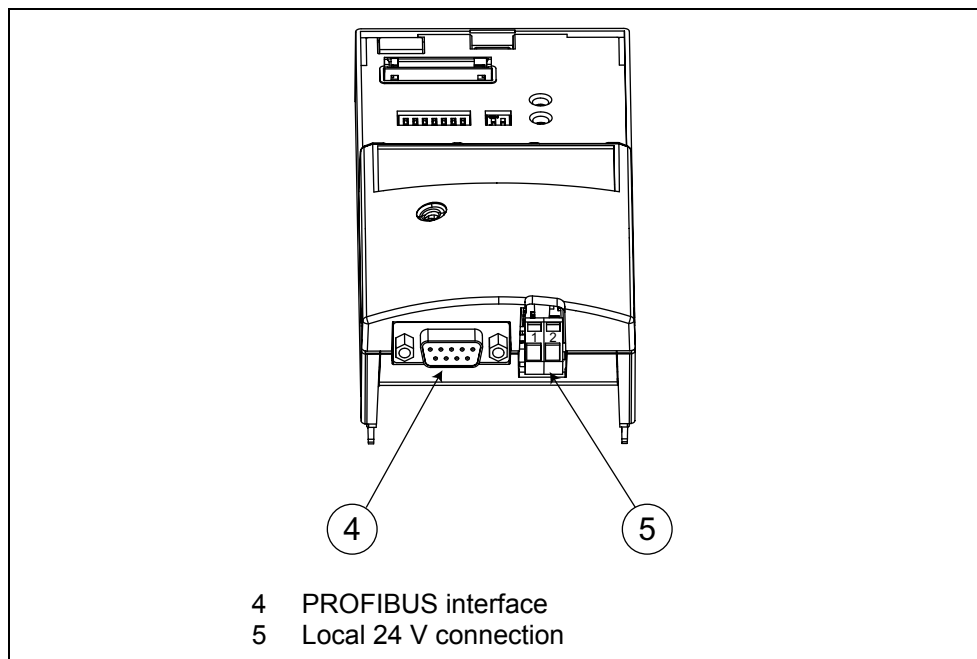

Fig. 4-5 PROFIBUS connection on communication board

4.4.1 Connection of the external 24 V voltage supply

The communication board is normally supplied by the mains supply to the inverter. The PROFIBUS communication board has its own separate 24 V supply connection, thereby allowing the communication board and inverter electronics to operate independently of the inverter mains supply (board is still capable of communicating even when the inverter power supply is switched off).

Terminal markings:

- 1 – +24 V
- 2 – 0 V

Remark: A regulated power supply is recommended.

Information about connection of the external 24 V voltage supply

The external 24 V voltage supply serves to ensure that communication with the inverter is possible as a PROFIBUS participant.

This means that parameter settings are possible in the inverter via PROFIBUS with an IBN-Tool.

Effect of the external 24 Volt supply on the inverter:

- All types of parameter transfers between PC and inverter are possible.
- Diagnosis information can be read from the inverter
- Supply to the digital interface of the inverter (inputs and outputs) is given.

- No supply to the analog periphery interface of the inverter (inputs and outputs). This also applies to operation as a digital input.
- It is not possible to start the motor when just the load supply of the inverter is switched on.

4.5 Connecting the bus cable using RS485 bus connectors



Warning

A inverter can be switched on unintentionally if the serial bus installation is not operated correctly. The bus must be started up by personnel who are qualified and trained in installing systems of this type.

Pin assignment of the bus connector

The PROFIBUS optional board has a 9-pin bus connector for connecting it to the PROFIBUS system. The terminals are short-circuit-proof and isolated.

Table 4-1 PIN assignment of sub D socket

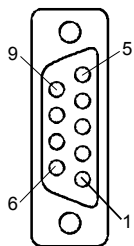

Pin	Designation	Meaning	Range
1	SHIELD	Ground connection	
2	-	Not assigned	
3	RxD/TxD-P	Receive/send data P (B/B')	RS-485
4	CNTR-P	Control signal	TTL
5	DGND	PROFIBUS data reference potential (C/C')	
6	VP	Supply voltage positive	5 V ± 10 %
7	-	Not assigned	
8	RxD/TxD-N	Receive/send data N (A/A')	RS-485
9	-	Not assigned	

4.5.1 Maximum cable lengths

RS-485-compliant transmission is the transmission mode used most frequently on PROFIBUS-DP. This requires a twisted, screened copper cable with one conductor pair.

A total of 124 devices can be connected to one PROFIBUS line. Up to 32 devices can be interconnected in a linear structure within one bus segment. If the configuration includes more than 32 nodes, repeaters (cable amplifiers) must be installed to link the individual bus segments.

The maximum cable lengths are dependent on the baud rate (transmission speed). The maximum cable lengths specified in the table below can be guaranteed only with PROFIBUS bus cables (e.g. Siemens PROFIBUS FC Standard cable available under order number (MLFB) 6XV1830-0EH10).

Table 4-2 Permissible cable length of one segment

Baud rate	Max. cable lengths of one segment [m]
9.6 to 187.5 kbaud	1000
500 kbaud	400
1.5 MBaud	200
3 to 12 MBaud	100

RS-485 repeaters can be installed to increase the length of a segment.

Cable installation rules

The bus cable must not be

- twisted
- stretched or
- compressed

during installation. Supplementary constraints as regards electromagnetic compatibility must also be observed.

Further relevant information can be found, for example, in Chapter 3 of the Compendium (6SE7080-0QX50 Edition AE, MASTERDRIVES Docu).

4.5.2 Bus connector

To connect the PROFIBUS cable to the communication board, a bus connector of one of the types described in the following table will be required.

Table 4-3 Recommended PROFIBUS connectors

Order No.	6GK1 500-0FC00	6GK1 500-0EA02
PG socket	No	No
Max. baud rate	12 MBaud	12 MBaud
Terminating resistor	On/Off switch	On/Off switch
Outgoing cable unit	180°	180°
Interfaces		
PROFIBUS nodes	9-pin bus connector	9-pin bus connector
PROFIBUS bus cable	4 modular terminals for wires up to 1.5 mm ²	4 modular terminals for wires up to 1.5 mm ²
Connectable PROFIBUS cable diameter	8 ± 0.5 mm	8 ± 0.5 mm

NOTE

We recommend only these two connectors since they can be used without difficulty for all MICROMASTER 4 models and are completely compatible in terms of outgoing cable unit angle.

For further PROFIBUS network components, please refer to the catalogue IK PI (order no.: E86060-K6710-A101-B1 at SPLS L ML and/or in the Intranet information: c4bs.spls.de).

4.5.3 Bus terminator

Each bus segment must have a resistor network, i.e. a bus terminator, at both ends.

Where the recommended bus connectors have been used, the bus terminator can be switched in and out by means of switches.

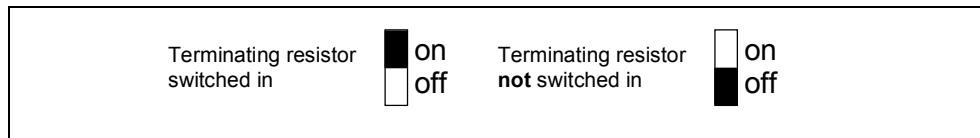

Fig. 4-6 Switch positions for activated or deactivated bus terminating resistors

If these bus connectors are not installed, the user must ensure that a bus terminating network is installed on the first and last bus nodes as specified in the diagram below.

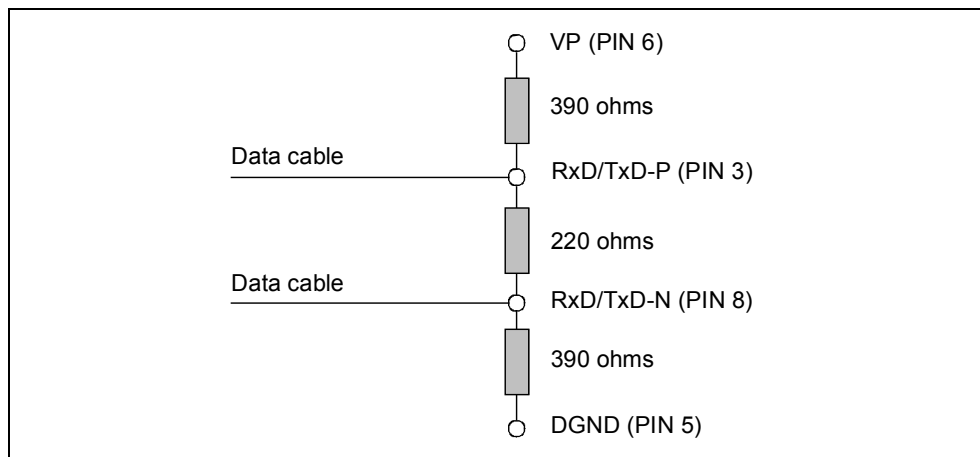

Fig. 4-7 Bus terminating network



WARNING

A bus segment must always be terminated at both ends by a terminating resistor. This is not the case, for example, if the last slave with bus connector is switched off, since the bus connector voltage is supplied by the station and the resistor is thus inoperative.

It must be ensured that all stations on which a terminating resistor is activated are supplied with power at all times.

4.5.4 Removing a bus connector

You can remove the bus connector with looped-through bus cable from the PROFIBUS-DP interface at any time without interrupting the data exchange on the bus.

4.5.5 Screening the bus cable / EMC precautions

The following EMC-related precautions must be taken to ensure interference-free PROFIBUS-DP operation, particularly in RS-485 data exchange mode:

Screening

The screen of the PROFIBUS cable must be contacted in the bus connector. Additional screening is provided via a screen clamp on the bus cable screen which must make 360° contact with the protective earth. The solid copper core must not be scored when the insulation is removed from the core ends. It must also be ensured that the screen of each bus cable is connected to protective earth at both the cabinet entry point and in the inverter housing.

NOTE about installation

The bus cables must be internally twisted and screened, and installed separately from power cables (minimum distance 20 cm). The braided screen and underlying laminated foil screen (if applicable) must be contacted in a 360°, positive connection at both ends, i.e. the screen on the bus cable between two inverters must be connected to the inverter housing at both ends. The same applies to the screen of the bus cable between the PROFIBUS-DP master and inverter.

Crossovers between bus and power cables must be laid at an angle of 90°.

Equipotential bonding

Differences in potential (e.g. due to different mains supplies) between the inverters and the PROFIBUS-DP master must be avoided.

- Recommended equipotential bonding cables:
 - ◆ 16 mm² Cu for equipotential bonding cables up to 200 m long
 - ◆ 25 mm² Cu for equipotential bonding cables of over 200 m long
- Equipotential bonding cables must be routed as close as possible to signal leads, i.e. that the area between the bonding conductor and signal lead is as small as possible.
- Equipotential bonding cables must be contacted in a 360° connection with the earth electrode/PE conductor.

Please carefully observe the information included in the
PROFIBUS Technical guidelines
"Set-up guidelines for PROFIBUS-DP/FMS" September 1998
Order no. 2.111

5 Starting up the PROFIBUS Board

NOTE

Before the inverter with connected PROFIBUS board is switched on, you should plug either the standard display panel (SDP), a basic operator panel (BOP) or an 'Advanced Operator Panel' (AOP) into the PROFIBUS board.

The PROFIBUS optional board may only be installed when the inverter power supply is disconnected.

5.1 PROFIBUS address

A minimum requirement for starting up the PROFIBUS optional board is the PROFIBUS address setting.

Two methods of setting the PROFIBUS address:

- Via the seven DIP switches on the communication board or
- via parameter "P0918".

DIP switches

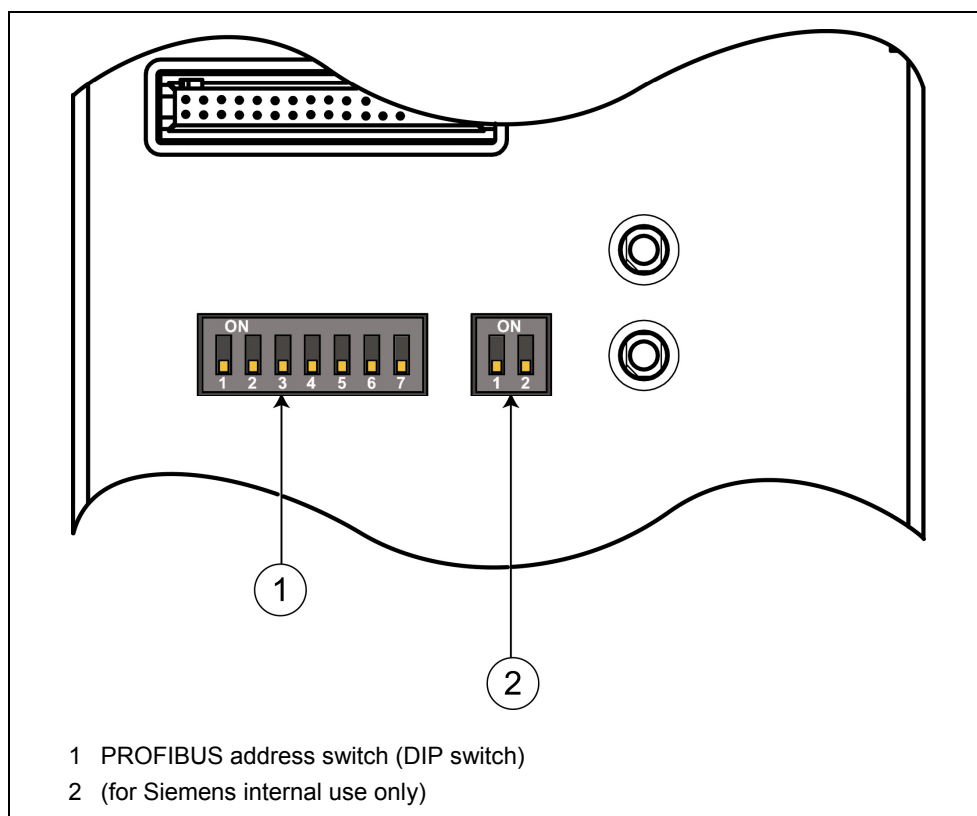

Fig. 5-1 View of DIP switch

The PROFIBUS address can be set to between 1 and 125, as shown in the following table, on DIP switches 1 to 7.

Switch number:	1	2	3	4	5	6	7
Add to address:	1	2	4	8	16	32	64
Example 1: Address = 3 = 1 + 2	on	on	off	off	off	off	off
Example 2: Address = 88 = 8 + 16 + 64	off	off	off	on	on	off	on

Some "addresses" have a special meaning:

Address	Meaning
0	PROFIBUS address is determined by P0918
1..125	Valid PROFIBUS address
126, 127	Invalid PROFIBUS address

Important NOTE

The inverter power supply must be switched off before the DIP switch settings are changed (if the communication board is already mounted on inverter). DIP switch setting changes do not take effect until the PROFIBUS has been restarted cold again. This cold restart must be initiated by switching the power off and then on again, irrespective of whether the board is supplied from the inverter mains supply or its own, separate 24 V connection.

5.2 Communication board parameters

The following parameters must be set to start up the PROFIBUS optional board:

Parameter	Content
P0918	PROFIBUS address
P0700	Fast selection command source
P1000	Fast selection frequency setpoint
r2050	Process data setpoint source (BICO)
P2051	Process data actual values (BICO)
P2041	Communication board functions
P2040	Process data telegram failure time
P0927	Modification source for parameters
r2054	Communication board diagnostics (see Section 7.3)

Parameter "P0918" (PROFIBUS address)

If address 0 is set on the DIP switches of the communication board (setting in delivery state), then the PROFIBUS address can be changed in parameter "P0918". Valid settings are 1 to 125 (default = 3).

Once a valid PROFIBUS address has been set on the switches, parameter "P0918" can no longer be changed. In this case, the parameter displays the PROFIBUS address set on the switches.

The "Reset inverter parameters to factory setting" function also resets the PROFIBUS address to 3 if it has been set originally via "P0918".

Parameters "P0700" and "P1000" (fast selection/process data master control)

The control word and setpoint sources can be selected quickly in parameters P0700 (select command source) and P1000 (select frequency setpoint) respectively.

Command source from PROFIBUS: P0700 = 6

Frequency target value from PROFIBUS: P1000 = 6

Note: P0719 must be 0

Parameters "r2050" and "P2051" (BICO)

Much greater flexibility is afforded by the interconnection of process data using binectors/connectors, see description "Use of binectors and connectors" in the reference manual.

Detailed connection of setpoints and actual values to and from the PROFIBUS optional board is parameterized in "r2050" and "P2051".

The following table shows the parameters specific to the PROFIBUS optional board relating to the connection of process data:

Table 5-1 Parameters for flexible interconnection of process data

Telegram:	PZD1 STW/ZSW	PZD2 HSW/HIW	PZD3	PZD4
Link values for setpoints master → inverter	r2050.00	r2050.01	r2050.02	r2050.03
Link parameters for actual values inverter → master	P2051.00	P2051.01	P2051.02	P2051.03

PZD: Process data

HSW: Main setpoint

STW: Control word

HIW: Main actual value

ZSW: Status word

NOTE

r2050 also acts as a display parameter via which the setpoints received by the PROFIBUS optional board can be checked.

Parameter "P2041" (communication board functions)

A number of advanced property settings for the PROFIBUS optional board can be made in indexed parameter "P2041".

For most applications, however, the defaults are adequate (value = 0). The following table shows the property setting options.

Table 5-2 Communication board functions

Parameter	Meaning	Value range
P2041.00	PPO type is specified by slave: Some (rare!) PROFIBUS masters require a configuration specified by the slave. This option can be programmed in this parameter.	0: PPO1 1: PPO1 3: PPO3
P2041.01	OP parameter in EEPROM: Modifications to parameter settings via SIMATIC HMI are stored permanently in the EEPROM or as volatile data in the RAM.	0: Permanent (EEPROM) 1: Volatile (RAM)
P2041.02	Internode communication failure: Reaction of communication board (as subscriber) after failure of a publisher	0: Generate alarm A704 and abort setpoint transmission to inverter (may activate fault 70) 1: Generate alarm A704 only
P2041.03	Select displayed diagnostics screen.	0: Standard diagnostics >0: Special diagnostics (for SIEMENS internal use only)

Process data monitoring

Two parameters determine how process data are monitored:

- Threshold monitoring on the PROFIBUS optional board (standard slave function according to PROFIBUS)
- Monitoring of the telegram failure time in the inverter with parameter "P2040"

The threshold monitoring function on the PROFIBUS optional board is normally activated. It can be deactivated by means of the PROFIBUS master configuring tool.

NOTE

The threshold monitoring function should not be deactivated!

Parameter "P2040", telegram failure time

Parameter "P2040" is set to determine whether setpoint transmission via PROFIBUS should be monitored by the inverter.

- "P2040" = 0 means: No monitoring
- "P2040" > 0 means: The value of "P2040" is the telegram failure time in milliseconds. (The default setting of the parameter is a value of >0!)

Fault 70 is activated if no new setpoints are received by the PROFIBUS optional board within the telegram failure period.

Important NOTE

Shutdown on faults can only take place if both monitoring functions are activated!

When the PROFIBUS optional board is in operation, parameter "P2040" should also be set to a value of > 0. The process data monitoring function is thus activated/deactivated solely via the PROFIBUS threshold monitor. The monitoring time then corresponds to the threshold monitoring time setting + the setting in "P2040".

NOTE

Process data whose complete control word (PZD1) is set to zero are not transferred from the PROFIBUS optional board to the inverter.

Result: Alarm A703 and possibly fault 70.

Inverter behaviour at "P2040=0"

If monitoring is switched off and the PROFIBUS Master system goes to the status Stop (e.g. S7 CPU), the inverter remains active with the last received target specifications (control word, frequency target value)!

Parameter "P0927", modification source for parameters

This parameter can be set to define the sources of parameter modifications.

Bit 0	PROFIBUS-DP	0: No 1: Yes
Bit 1	BOP	0: No 1: Yes
Bit 2	PC-inverter assembly set (USS on the BOP interface)	0: No 1: Yes
Bit 3	Local RS-485 interface (terminal 14/15 and USS)	0: No 1: Yes

The default setting for all bits is 1, i.e. parameters can be modified from all sources.

5.2.1 Starting process for the MICROMASTER 4 with communication board

The following description refers to the start-up of the MICROMASTER 4. Knowledge of the project planning software STEP7 is a pre-requisite here. This information does not take the available extended configurations in consideration.

1. Configuration of a MICROMASTER 4 with STEP 7

In STEP 7 „Hardware configuration/HW-config“ you can open the catalogue file PROFIBUS-DP → SIMOVERT; check whether the MICROMASTER 4 is there. If this is not the case, the GSD file (Geräte Stamm Datei; device data file) can be simply imported into the hardware catalogue.

Use the command under Extras → „Install new GSD“ in HW-Config. The GSD file is saved on the documentation CD which was supplied with the PROFIBUS component or is available as a download in the Internet.

The MICROMASTER 4 is now in the catalogue under the path: PROFIBUS-DP → Additional Field Devices → Drives → SIMOVERT

Select PP0 type 3, if you do not want to read or write parameters; select PP0 type 1, if you want to read/write parameters. If you want to read inverter data such as motor power from the inverter, you should select one of the options with the PZD words 3 and 4 because this is then possible without the PKW mechanism.

The HW configuration will then ask you to enter a bus address. STEP 7 will automatically show logical E/A addresses (PLC periphery addresses). However you can change these.

2. Setting the parameters on the MICROMASTER 4

Start with the factory settings of the MICROMASTER 4. If necessary, set this status with P0010 = 30 and P970 = 1.

There are two ways in which you can set the PROFIBUS address:

- Set P0003 = 3 and set the bus address in P0918.
- You can also set the bus address with the DIP switches (left switch block, the lowest value bit is on the far left). The DIP switch settings come into effect when the MICROMASTER is next switched on and they overload P0918.

Set P0700 = 6 and P1000 = 6; this enables full Profibus control.

MM420 MICROMASTERS with 1.05 Software (see r0018) have a P2040 standard value of 0 (Profibus monitoring time in ms); we recommend the setting 20 here so that the drive can stopped with F0070 if there is a Profibus error (e.g. plug has been removed) or if the PLC goes to STOP. 20ms is the standard value for other MICROMASTER 4 devices.

3. Making the MICROMASTER 4 ready for operation

Before you start up the motor, you should check the Profibus control system functions. To do this, remove the motor cable from the clamps U, V and W. The output frequency is shown on an AOP or BOP Display.

When the motor is ready for starting, set P0010 = 1 and set all start-up parameters as outlined in the operating instructions for the MICROMASTER or in the parameter list. Finish with P3900 = 1 or 3; these calculate the motor data. Parameter P0010 is set to 0 again. The inverter cannot become active if P0010 = 1.

Ensure that the motor can turn safely.

4. Controlling the MICROMASTER with the PLC

If PP03 has been selected you have 2 output words ,(PZD1 and PZD2) from the PLC, which correspond with the MICROMASTER control value and frequency target value, and 2 input words which are the MICROMASTER status word and the actual frequency.

If you select PP01, the first 4 input and output words refer to read/write parameter data (PKW data). The PKW output words can now be set to zero. Frequency target value and actual value are normalised so that 4000hex corresponds with 50Hz. The highest value which should be sent is 7FFF.

The normalisation frequency can be changed in P2000.

The following are some typical control and status words. The status words assume that the MICROMASTER has reached its frequency target value (where applicable). The data sequence is control word, frequency target value, status word, actual frequency.

The drive is started when the control word 047E is sent followed by 047F (Edge of Bit 0: EIN)

Drive is ready for forward run:
047E 0000 FA31 0000

Let drive run forwards at 12.5Hz:
047F 1000 FB34 1000

Let drive run forwards at 50Hz:
047F 4000 FB34 4000

Let drive run backwards at 12.5Hz:

0C7F 1000 BB34 1000

Drive switched off when error occurs:

0C7F 1000 FA38 0000

Reset error:

04FE 0000 FA31 0000

The structure of the control and status words is outlined in Section 3.3 of this manual.

5. Parameter handling

If you have selected PP01, the first 4 input and output words can be used for reading and writing parameters. For examples please see Section 3.4 and 3.4.1 of this manual.

6 Links to PROFIBUS-DP Master Systems

6.1 General

PROFIBUS slaves have different performance characteristics. To ensure that each slave with its individual properties can be correctly addressed by any master, the characteristic features of a slave are listed in its device data file (GSD).

Device data file (GSD)

The device master data file for the MICROMASTER 4 PROFIBUS optional board (SI0280B5.GSD) is stored on the documentation CD for the PROFIBUS component. Alternatively, it can be downloaded from the Internet (www.profibus.com).

6.2 Operation on SIMATIC S5

The MICROMASTER 4 is operated as a normal standard DP slave on a SIMATIC S5. The IM308C is normally installed as the master module. The COM PROFIBUS tool can be used to configure the master station.

You will find the MICROMASTER 4 under DP Slaves in the "Drives", "SIMOVERT" group.

For further information about configuring the data exchange between a MICROMASTER 4 and a SIMATIC S5, please refer to the description of function block package DVA-S5.

COM PROFIBUS

Earlier COM PROFIBUS versions or the latest version COM PROFIBUS V5.1, for Win 95/98/NT/2000/Millennium.

Order number for version 5.1 (order from: EWK):

Basic MLFB: 6ES5 895-6SE03

Update: ... -0UG4

Function block package DVA_S5

Function block package DVA_S5 (Variable-Speed Drives on SIMATIC S5) organizes the data exchange between SIMATIC and SIMOVERT slaves in accordance with the PROFIdrive Profile version 2.0 and thus simplifies the creation of the user program. A uniform data block is always provided as the data interface, irrespective of which S5-CPU executes the program. The programmer does not therefore need any in-depth knowledge of the SIMATIC S5 system architecture or any system functions required.

Function block package DVA_S5 (version 3.0) can be ordered from A&D SE Fürth under order number (MLFB) 6DD1800-0SW0.

6.3 Operation on SIMATIC S7

PROFIBUS-DP interfaces in SIMATIC S7

A selection of the possible PROFIBUS-DP master-capable components for the automation system SIMATIC S7 can be seen in the following table.

Further available PROFIBUS-DP master-capable components can be found in the catalogue CA01 under www.ad.siemens.de/ca01.

Table 6-1 Example products for SIMATIC S7 DP Master

	CPUs with integrated PROFIBUS DP Master	Switching components
SIMATIC S7 300	CPU 315-2 DP CPU 316-2 DP CPU 318-2 DP ...	CP 342-5 ...
SIMATIC S7 400	CPU 412-2 DP CPU 413-2DP CPU 414-2DP CPU 416-2DP ...	CP 443-5 Extended IM 467 ...

The master station as the complete PROFIBUS network is configured in the STEP 7 Hardware Manager.

MICROMASTER 4 as PROFIBUS-DP slave on S7

The MICROMASTER 4 can be operated on a SIMATIC S7 as two different slave types:

- As a DP slave with DP standard functionality
- As a DP slave with extended functionality for SIMATIC S7

MICROMASTER 4 as DP slave with DP standard functionality

The MICROMASTER 4 with standard functions uses GSD as a base. It appears in the STEP 7 HW-Catalogue directly below the file PROFIBUS-DP → Additional Field Device → Drives → SIMOVERT.

The communication board based on the integrated GSD can utilize the following functions:

- Utilisation of the existing PPO types
- Utilisation of 4/8/8 PZD for process data (MICROMASTER 420/440/430)

MICROMASTER 4 as DP slave with extended functionality

The extended scope of functions includes:

- Acyclical communication with a SIEMENS start-up tool (e.g. STARTER) and SIMATIC HMI
- Optional configuration of process data
- Utilization of internode data communication

The MICROMASTER 4 with extended functionality is based on an S7-specific configuring software add-on called the "Slave Object Manager" or abbreviated "SlaveOM".

After the Slave Object Manager has been installed in STEP 7, the MICROMASTER 4 is displayed as a separate folder in the STEP 7 HW Catalogue (under the SIMOVERT folder).

The Slave Object Manager replaces and extends the functionality of the GSD-based, STEP 7-integrated option.

The Slave Object Manager is an integral component of the following products:

- "Drive ES Basic V5.1SP1" 6SW1700-5JA00-1AA0
- "Drive ES SIMATIC V5.1" 6SW1700-5JC00-1AA0
- "Drive ES PCS7 V5.1" 6SW1700-5JD00-1AA0

(these products require STEP 7 version 5.1 SP1 or PCS7 version 5.1.)

Further information about configuring the data exchange between a MICROMASTER 4 and a SIMATIC S7 can be found in the description of block package "Drive ES SIMATIC" or in the online help of the Slave Object Manager.

Optional configuration

Up to four process data in the MICROMASTER 420 and up to eight process data in the MICROMASTER 440/430, separated according to setpoints and actual values, can be configured in each telegram.

The data exchange can be optionally configured for all DP masters configured with STEP 7.

Utilization of internode data communication

This mode allows permits slaves to intercommunicate directly, instead of indirectly via the PROFIBUS-DP master.

Internode communication can be utilized only if the installed PROFIBUS-DP master supports the internode functionality. This includes, for example, all S7-CPU's with "equidistance" ("clocking") capability in the catalogue.

Optional configuration and internode data communication are programmed completely on the "Configuration" card in the Slave Object Manager. The setpoints and actual values need only be interconnected correctly in the drive.

Standard function blocks for data exchange with MICROMASTER 4

The "Drive ES SIMATIC" package contains standard function blocks which implement the exchange of data between the drive and SIMATIC S7 in accordance with DRIVEProfile, version 2.0 or 3.0. These blocks make it easier to write the user program.

6.4 Exchanging data using internode communication function

The "Internode communication" function is described in detail in PROFIdrive Profile, version 3.0.

Internode communication enables slaves to communicate directly with one another instead of routing data indirectly via the DP master. This function can be utilized only in conjunction with a DP with capability "constant bus cycle time".

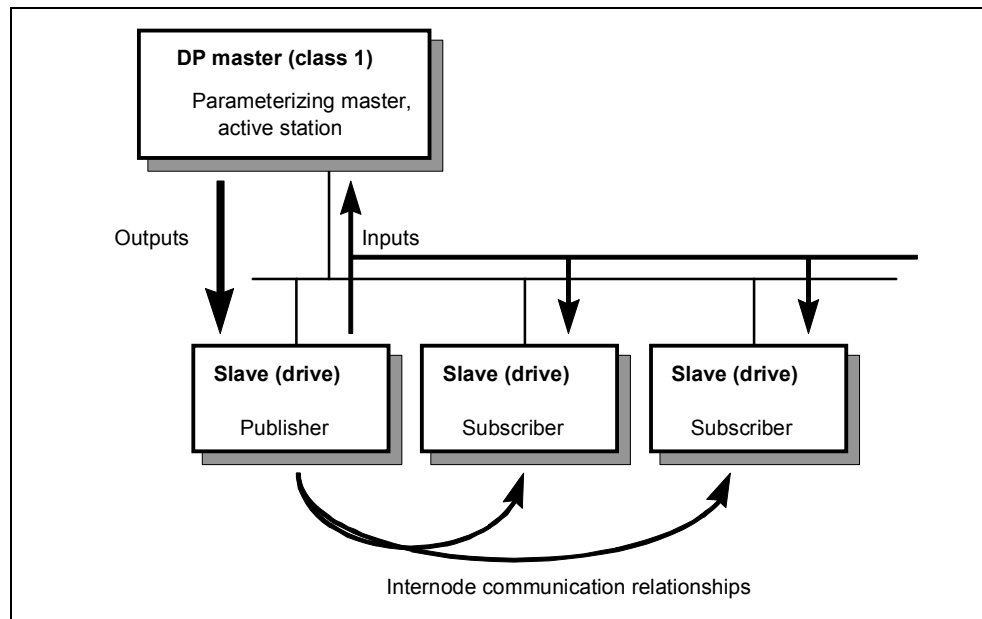

Fig. 6-1 Principle of internode data communication on PROFIBUS-DP

The data are generated by the transmitter (Publisher) and received by one or several receivers (Subscribers).

Transmitter

All input data of a DP slave with internode communication capability constitute transmit data with respect to internode exchanges. They can be received by the DP master or by internode-capable DP slaves. ("Input data" in the context of PROFIBUS-DP are data with the DP slave sends to the DP master).

It is not necessary to configure internode communication transmitters explicitly.

Receiver

The sources for setpoints are parameterized. The following can be selected as sources:

- The output data of the DP master
- The input data of a DP slave as an internode communication transmitter (actual values in the case of drives).

Master output data and slave input data can be mixed as required (with word granularity). ("Output data" in the context of PROFIBUS-DP are data which the DP slave receives from the DP master).

Logical communication relationships with internode communication

You can configure the communication relationships between DP slaves using the internode communication function, e.g.:

- "Broadcast principle": One master drive specifies a master setpoint for all slave drives.
- "Peer-to-peer principle": A setpoint is forwarded from one drive to the next.

A communication relationship is also referred to as a "channel" or "link".

Quantity framework from slave viewpoint

The MICROMASTER 420/440/430 has a total of 4/8/8 words of receive data (setpoints) and 4/8/8 words of transmit data (actual values).

A source-destination relationship can be defined for this type of data word, e.g. setpoint 1 is sent by DP master; setpoint 2 is sent by an internode-capable slave and not by the DP master.

Number of transmit channels:

A broadcast channel which the DP master and any number of DP slaves can receive, i.e. a maximum of 4 data words on MICROMASTER 420 and 8 words on MICROMASTER 440/430

Number of receive channels:

Maximum 4 via internode (+ one from the master), i.e. the 4 setpoints could come from 4 different sources on the PROFIBUS.

Preconditions

- STEP 7, version 5.1 SP1
- Drive ES Basic V5.1SP1
- S7 PROFIBUS master system with the internode functionality (Catalogue property "Equidistance" capability (clocking))
- Internode-capable DP slaves as communication partners (e.g. drives or ET200)

Internode communication is programmed with the SlaveOM in the "Configuration" screen.

The sequence of configuring operations is described in the documentation for Drive ES Basic. The project planning procedure is outlined in the quick start-up instructions for the Drive ES Basic V5.1 in Chapter 5.2 and or in the project planning instructions "PROFIBUS-DP with Motion Control" the Erlangen application centre

Example of application of internode communication

The diagram below shows an internode communication configuration with two internode transmitters (Publishers) and one drive as an internode receiver (Subscriber).

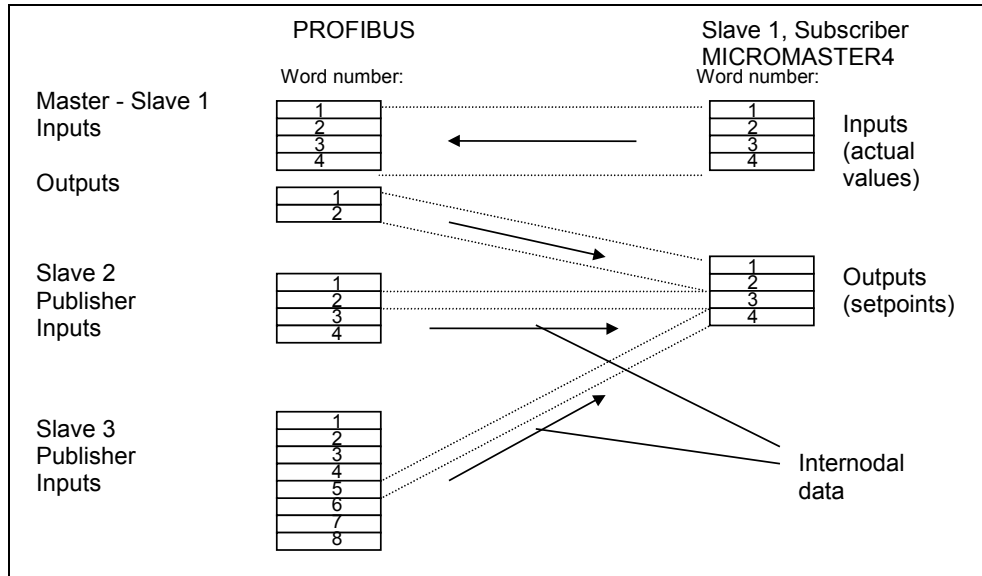

Fig. 6-2 Example of application of internode communication

6.5 SIMATIC HMI (Human-Machine Interface)

You can access a MICROMASTER 4 directly using a SIMATIC HMI as the PROFIBUS master.

A MICROMASTER 4 reacts to a SIMATIC HMI in the same way as it does to a SIMATIC S7. As regards access operations to drive parameters, the following simple formula applies:

- Parameter number = data block number
- Parameter subindex = data block offset

All SIMATIC OPs and TDs with final digit 7 are suitable.

ProTool

The SIMATIC HMI is configured with "ProTool".

The following specific settings for drives must be noted when ProTool is used as the configuring tool:

Controls: Protocol always **"SIMATIC S7-300/400"**

Other parameters:

Field	Value
Network parameter - profile	DP
Network parameter - baud rate	(optional)
Communication partner - address	(PROFIBUS address of the drive)
Communication partner - slot/subrack	don't care, 0

Variables: "General" index card:

Field	Value
Name	(optional)
Control	(optional)
Type	Depending on addressed parameter value, e.g.: INT: for I2, O2 DINT: for I4, O4 WORD: for V2, L2 REAL: for NF
Area	DB
DB (data block number)	Parameter number 1 ... 3999
DBB, DBW, DBD (data block offset)	Subindex 0: for nonindexed parameters 0 ... 120: for indexed parameters
Length	(not activated)
Acquisition cycle	(optional)
No. of elements	1
Decimal places	(optional)

NOTE

- You can operate a SIMATIC HMI and a drive together independently of the rest of the automation system.
A simple "point-to-point" link with just two nodes is possible.
 - The HMI "Variables" functions can be used for drives. Other functions cannot be used (e.g. "Messages" or "Recipes").
 - Individual parameter values can be accessed, but access operations to complete arrays, descriptions or texts are not possible.
 - The diagnostic output on the SIMATIC HMI is limited. In the case of accessing difficulties, the diagnostic parameters of the communication board, i.e. r2054.03 and ff., will be helpful, see Chapter 1 "Diagnostics and Troubleshooting".
-

6.6 Operation on external master systems

The MICROMASTER 4 can operate on an external master only as a standard DP slave with the respective functions.

Required GSD file: SI0280B5.GSD

The device data file (GSD file) contains all information required by a DP master system to integrate the MICROMASTER 4 into its PROFIBUS-DP configuration as a standard DP slave.

Provided the external master system allows the direct integration of GSD files, file SI0280B5.GSD can be copied directly into the appropriate subdirectory.

If the external master is not compatible to this extent, the necessary information must be derived manually from file SI0280B5.GSD.

Exchanging data with MICROMASTER 4 without standard data blocks

In cases where function block package "Drive ES SIMATIC" cannot be used, the user program must adhere to the system properties with respect to data consistency. This means in particular that system functions of SIMATIC S7 (SFC14 (DPRD_DAT) and SFC15 (DPWR_DAT)) or corresponding means must be used to access > 2 words for the PKW and PZD areas.

In this case, the PKW area and PZD area must be regarded as two mutually independent, consistent data areas.

	PKW	PZD
PPO1	(4 words)	(2 words)
PPO2	(4 words)	(6 words)
PPO3		(2 words)
PPO3	–	(6 words)

Extended PZD for MICROMASTER 420:

	(4 words)	(4 words)
	–	(4 words)

Extended PZD for MICROMASTER 440/430:

	(4 words)	(8 words)
	–	(8 words)

7 Diagnostics and Troubleshooting

There are three types of diagnostic display:

- LED
- Alarm numbers
- Diagnostic parameter

7.1 Diagnostics using LED display

The three-coloured LED display is on the front panel of the PROFIBUS-DP communication board. It provides instantaneous information about the status of the board.

Possible LED displays are explained in the table below.

Table 7-1 LED display on PROFIBUS-DP communication board

LED	Diagnostic information
off	No power supply
red, flashing fast	Invalid PROFIBUS address on DIL switch (126/127 is invalid) or hardware fault or software error
red on	Startup and no communication (yet) with the inverter or new communication board configuration, after modification of a board parameter If this status is steady, then the inverter or PROFIBUS optional board is defective.
orange flashing	Communication link to inverter has been established No connection to PROFIBUS, e.g. PROFIBUS connector is not inserted or PROFIBUS master disconnected.
orange on	Communication link to inverter and connection to PROFIBUS have been established, but no cyclical data exchange is taking place.
green flashing	Cyclical process data exchange in progress, but setpoints invalid (control word = 0), e.g. because SIMATIC master is in "Stop" state
green on	Cyclical process data exchange in progress and o.k.

NOTE

If a class 2 master with acyclical communication (PC or HMI) is installed, but no class 1 master with cyclical data exchange, then the LED displays "orange on".

7.2 Diagnostics using alarm number (alarms and faults)

If alarms and faults occur on the PROFIBUS communication link, corresponding alarm numbers are displayed on the inverter (BOP/AOP).

Alarms

Table 7-2 Alarm displays on inverter

Alarm number	Meaning
A700	Cause: The parameter or configuring settings by the PROFIBUS master are invalid. Remedy: Correct the PROFIBUS configuration
A702	Cause: The link to the PROFIBUS is interrupted. Remedy: Check connector, cable and PROFIBUS master
A703	Cause: No setpoints, or invalid setpoints (control word = 0) are being received from the PROFIBUS master Remedy: Check setpoints from the PROFIBUS master. Switch SIMATIC CPU to "RUN".
A704	Cause: At least one configured internode transmitter is not yet active, or has failed. Remedy: Activate internode transmitter.
A705	Cause: No actual values received from inverter. Remedy: None (fault is in inverter)
A706	Cause: PROFIBUS-DP communication board: Software error. Remedy: None (fault on the PROFIBUS-DP communication board, for details see diagnostic parameter)
A710	Cause: Converter has detected failure of communication link to PROFIBUS-DP communication board Remedy: None (communication board may need to be replaced)
A711	Cause: Invalid value of a CB?? parameter. Remedy: Check P0918 (PROFIBUS address) and P2041 (communication board parameters)

Faults

Table 7-3 Fault displays on inverter

Alarm number	Meaning
A070	Cause: No setpoints received from PROFIBUS-DP communication board. Triggered by A702/A703/A704. The telegram failure time set in P2040 has run out. Remedy: Check connection to communication partners and ensure valid control word (see A702/A703/A704)

7.3 Diagnostics using diagnostic parameter

Detailed diagnostic information is displayed in parameter r2054. The content of the diagnostic parameter depends on the selected diagnostic screen (see communication board parameter P2041.03).

7.3.1 Identification of the communications components

The reading parameter r2053 shows corresponding identification data.

Table 7-4 Identification and firmware information

Parameter	Meaning
r2053.00	Communication board type: 0: Converter without communication option 1: PROFIBUS 2: DeviceNet 56: not defined
r2053.01	Firmware version
r2053.02	Constant "0"
r2053.03	Firmware date (year)
r2053.04	Firmware date (day / month)

7.3.2 Standard diagnostics

Table 7-5 Standard diagnostic parameter

(when P2041.03 = 0!)

Parameter	Meaning
r2054.00	PROFIBUS status: 0: Off 1: Baud rate search 2: Baud rate found 3: Cyclical data exchange (>100: Other diagnostic screen active)
r2054.01	Cyclical PKW channel configured and length of cyclically transmitted setpoints and actual values p: 1/0, PKW configured or not xx: Length setpoints, yy: Length actual values Example: 10404: PKW configured, 4 setpoints and actual values each 204: No PKW configured, 2 setpoints and 4 actual values
r2054.02	Number of acyclical links with class 2 master (PC, OP): 0...2
r2054.03	Error number of last unsuccessful parameter access operation via an acyclical link (see Table 7-6)
r2054.04	Parameter number of last unsuccessful parameter access operation
r2054.05	Subindex of last unsuccessful parameter access operation
r2054.06	Internode communication: Active publishers and number of configured publishers. Decimal 0...11114. 1x = Publisher 1, ..., 1xxx = Publisher 4 active Last decimal place: Number of configured publishers Example: 11114: Four publishers configured, all active 1013: Three publishers configured, first and third active

Parameter accessing error (r2054.04), error numbers < 240 correspond to PKW error numbers:

Table 7-6

No.	Cause	Remedy (e.g. in ProTool)
No. 0 .. 199: Parameter access has been converted to a PKW request. Error detected in inverter. Additional info in r2054.05, r2054.06: Parameter number, index word		
0	Parameter number does not exist	Check data block number
1	Parameter value cannot be modified	-
2	Minimum/maximum not reached or exceeded	-
3	Subindex does not exist	Check data block offset
4	Access to single value with array identifier	Set data block offset = 0
5	Access to word with double word request or vice versa	Use correct data type (e.g. INT for word, DINT for double word)
6	Setting not allowed (resetting only)	-
7	Descriptive element cannot be modified	-
11	No status as master control	-
12	Key word missing	-
17	Request cannot be processed due to operating state	-
101	Parameter number currently deactivated	-
102	Channel not wide enough	-
104	Illegal parameter value	-
106	Request not implemented	-
200/ 201	Modified minimum/maximum not reached/exceeded	Minimum/maximum can be further limited in operation
No. 240-249: Parameter access is incorrectly formatted. Error detected on the PROFIBUS-DP communication board. Additional info in r2054.05, r2054.06: Parameter number or S7 data block number, subindex or S7 data block offset.		
240	Error in variable address (no additional info)	Legal: "Data block" area
241	Data block number illegally formatted	Legal: 1...31999
242	Data block offset illegally formatted	Legal: 0...116
243	Illegal "type"	Legal: CHAR, BYTE, INT, WORD, DINT, DWORD, REAL
244	Illegal "Number of elements" on accessing parameter value	Legal: Effectively 2 or 4 bytes
248	Illegal text/description modification	-
249	Inconsistency in write request: "Type" and "Number of elements" does not match "Data type" and "Data length"	(error in communication partner)
No. 250: Parameter access has been converted to a PKW request. Response from inverter is errored. Error detected on the PROFIBUS-DP communication board. Additional info in r2054.05, r2054.06: Parameter number, subindex.		
250	PKW response does not match request	(error in inverter)
No. 251: Error detected on the PROFIBUS-DP communication board; no additional info		
251	Response too long for response telegram	(error in communication partner)

7.3.3 Special diagnostics for start-up personnel

Irrespective of the setting in P2041.03, the PROFIBUS-DP communication board attempts to send the following diagnostics to the inverter after detecting a software error:

Parameter	Meaning
r2054.00	65535: Identifier for details of a software error
r2054.01 ... r2054.05	Name of module in which error has been detected (ASCII code)
r2054.06	Code line in which error has been detected
r2054.07 r2054.08	Error details

8 Appendix

8.1 Technical data

Table 8-1 Technical data

Order number	6SE6400-1PB00-0AA0
Size (height x width x depth)	161 mm x 73 mm x 43.5 mm
Pollution severity	Pollution severity 2 according to IEC 60 664-1 (DIN VDE 0110/T1), No moisture condensation permitted in operation
Mechanical strength	Acc. to DIN IEC 60 068-2-6 (with correctly installed board)
In stationary state	
• Deflection	• 0.15 mm in 10 Hz to 58 Hz frequency range
• Acceleration	• 19.6 m/s ² in > 58 Hz to 500 Hz frequency range
During transportation	
• Deflection	• 3.5 mm in 5 Hz to 9 Hz frequency range
• Acceleration	• 9.8 m/s ² in > 9 Hz to 500 Hz frequency range
Climate class	Class 3K3 to DIN IEC 60 721-3-3 (in operation)
Cooling method	Natural air cooling
Permissible ambient or coolant temperature	
• In operation	-10° C to +50° C (14° F to 122° F)
• In storage and in transit	-25° C to +70° C (-13° F to 158° F)
Relative humidity (Permissible humidity rating)	• ≤ 85 % during operation (condensation not permissible) • ≤ 95 % during storage and in transit
Supply voltage	6.5 V ± 5 %, max. 300 mA, internal from basic inverter or 24V ± 10 %, max. 350 mA, from external source Remark: A regulated power supply is recommended
Output voltage	5 V ± 10 %, max. 100 mA, electrically isolated supply • for the bus termination of the serial interface or • for the supply of an OLP (Optical Link Plug)
Data transmission rate	Max. 12 MBaud

8.2 EMC information

The board complies with the following standards governing radio emissions and interference immunity:

- Radio emissions in accordance with EN55011 1991 Class A
- Interference immunity in accordance with IEC 60 801-3 and EN61000-4-3

9 Glossary

AK	Request identifier
DP	Distributed I/Os
ES	Engineering System
GSD	Device data file (<u>G</u> eräte <u>S</u> tamm <u>D</u> atei)
HSW	Main setpoint
HIW	Main actual value
HMI	Human Machine Interface
LWL	Fiber optic conductor
OP	Operator Panel
OLP	Optical Link Plug
OLM	Optical Link Module
PNU	Parameter number
PWE	Parameter value
PKW	Parameter identifier
PZD	Process data
STW	Control word
SlaveOM	Slave Object Manager
TD	Text Display
ZSW	Status word

Suggestions and/or Corrections

To
Siemens AG
Automation & Drives
Group
SD VM 4
P.O. Box 3269

D-91050 Erlangen
Federal Republic of Germany

[Suggestions for technical documentation](#)

Suggestions

Corrections

For Publication/Manual:

MICROMASTER
PROFIBUS Optional Board

User Documentation

From

Name:

Company/Service Department

Address: _____

Phone: _____ / _____

Fax: _____ / _____

Order number: 6SE6400-5AK00-0BP0

Date of Issue: Edition 02/02

Should you come across any printing errors when reading this publication, please notify us on this sheet.

Suggestions for improvement are also welcome.

Siemens AG
Automation and Drives Group (A&D)
Standard Drives (SD) Division
Postfach 3269, D-91050 Erlangen
Federal Republic of Germany

© Siemens AG, 2001
Subject to change without prior notice

Siemens Aktiengesellschaft

Order No.: 6SE6400-5AK00-0BP0
Printed in the Federal Republic of Germany
02/02

