

SIEMENS

SIMATIC

RS 485 Repeater

Manual

<u>Preface</u>	1
<u>Introduction</u>	2
<u>Description</u>	3
<u>Installation</u>	4
<u>Connecting</u>	5
<u>Technical data</u>	6
<u>Dimension drawings</u>	7

Legal information

Warning notice system

This manual contains notices you have to observe in order to ensure your personal safety, as well as to prevent damage to property. The notices referring to your personal safety are highlighted in the manual by a safety alert symbol, notices referring only to property damage have no safety alert symbol. These notices shown below are graded according to the degree of danger.

⚠ DANGER
indicates that death or severe personal injury will result if proper precautions are not taken.
⚠ WARNING
indicates that death or severe personal injury may result if proper precautions are not taken.
⚠ CAUTION
with a safety alert symbol, indicates that minor personal injury can result if proper precautions are not taken.
CAUTION
without a safety alert symbol, indicates that property damage can result if proper precautions are not taken.
NOTICE
indicates that an unintended result or situation can occur if the corresponding information is not taken into account.

If more than one degree of danger is present, the warning notice representing the highest degree of danger will be used. A notice warning of injury to persons with a safety alert symbol may also include a warning relating to property damage.

Qualified Personnel

The product/system described in this documentation may be operated only by **personnel qualified** for the specific task in accordance with the relevant documentation for the specific task, in particular its warning notices and safety instructions. Qualified personnel are those who, based on their training and experience, are capable of identifying risks and avoiding potential hazards when working with these products/systems.

Proper use of Siemens products

Note the following:

⚠ WARNING
Siemens products may only be used for the applications described in the catalog and in the relevant technical documentation. If products and components from other manufacturers are used, these must be recommended or approved by Siemens. Proper transport, storage, installation, assembly, commissioning, operation and maintenance are required to ensure that the products operate safely and without any problems. The permissible ambient conditions must be adhered to. The information in the relevant documentation must be observed.

Trademarks

All names identified by ® are registered trademarks of the Siemens AG. The remaining trademarks in this publication may be trademarks whose use by third parties for their own purposes could violate the rights of the owner.

Disclaimer of Liability

We have reviewed the contents of this publication to ensure consistency with the hardware and software described. Since variance cannot be precluded entirely, we cannot guarantee full consistency. However, the information in this publication is reviewed regularly and any necessary corrections are included in subsequent editions.

Table of contents

1	Preface	5
2	Introduction	7
3	Description	9
3.1	Area of application and properties	9
3.2	Design of the RS 485 repeater	11
4	Installation	13
4.1	Installing and uninstalling the RS 485 repeater	13
5	Connecting	17
5.1	RS 485 Repeater in ungrounded and grounded operation	17
5.2	Connecting the power supply	20
5.3	Connecting the bus cable	21
5.4	Configuration options with the RS 485 repeater	22
6	Technical data	25
6.1	General technical data	25
6.1.1	Standards and approvals	25
6.1.2	Electromagnetic Compatibility	30
6.1.3	Shipping and storage conditions for modules and backup batteries	32
6.1.4	Mechanical and ambient climatic conditions for S7-300 operation	33
6.1.5	Specification of dielectric tests, protection class, degree of protection, and rated voltage of S7-300	35
6.2	Technical data the RS 485 Repeater	36
7	Dimension drawings	39
7.1	Dimension drawings	39
	Glossary	41
	Index	45

Preface

Introduction

This manual describes the RS 485 repeater.

It supports you during the configuration, installation and commissioning. It is intended for people who work in the following areas: the configuring, commissioning and servicing of automation systems.

Basic knowledge required

This manual presumes general knowledge in the field of automation engineering.

Range of validity of this manual

The manual is valid for the RS 485 repeater with the order number 6ES7972-0AA02-0XA0.

Additional support

If you have any questions relating to the products described in this product information and do not find the answers in this document, please contact your local Siemens representative on the Internet (<http://www.automation.siemens.com/partner/>).

A guide to the technical documentation provided for the various SIMATIC products and systems is available on the Internet (<http://www.siemens.com/simatic-tech-doku-portal>).

The online catalog and ordering systems are available on the Internet (<http://www.siemens.com/automation/mall>).

Technical Support

You can contact Technical Support for all Industry Automation products by means of the Internet Web form for the Support Request on the Internet (<http://www.siemens.com/automation/support-request>).

Additional information about Siemens Technical Support is available on the Internet (<http://www.siemens.com/automation/service>).

Service & Support on the Internet

In addition to our documentation, we offer a comprehensive knowledge base. On the Internet (<http://www.siemens.com/automation/service&support>).

There you will find:

- Our Newsletter, which constantly provides you with the latest information about your products.
- The right documentation for you using our Service & Support search engine.
- The bulletin board, a worldwide knowledge exchange for users and experts.
- Your local contact for Automation & Drives in our contact database.
- Information about on-site services, repairs, spare parts, and lots more.

Introduction

This chapter

This chapter describes the RS 485 repeater in detail.

This includes:

- Description of the RS 485 repeater
- The maximum cable lengths between two RS 485 repeaters
- The functions of the various operating elements and terminals
- Mounting and removing
- information about grounded and nongrounded operation
- Connecting the power supply and bus line
- Technical specifications and the block diagram
- Dimension drawings

Diagnostic Repeater

Compared to the RS 485 repeater, the Diagnostic Repeater has new characteristics: Diagnostic function and modeling as the DP slave. For additional information, refer to the Diagnostic Repeater for PROFIBUS DP manual on the Internet (<http://support.automation.siemens.com/WW/view/en/7915183>).

Description

3.1 Area of application and properties

Order number

6ES7972-0AA02-0XA0

What is the RS 485 repeater?

The RS 485 repeater amplifies data signals (amplitude, edge slope and signal width) on bus lines and couples segments.

Application of the RS 485 Repeater

The RS 485 repeater connects two PROFIBUS or MPI segments using RS 485 technology with maximum 32 nodes. It enables transfer rates from 9.6 kbps to 12 Mbps.

You need an RS 485 repeater if:

- More than 32 nodes (maximum 127, including repeaters) are connected to the bus
- Segments are operated ungrounded on the bus (electrical isolation of segments)
- The maximum cable length of a bus segment is exceeded (see the table below)
- Help is required during the commissioning
 - Switch for disconnecting segments
 - Display of bus activity
 - Disconnecting a bus segment in the case of incorrectly inserted terminating resistors
- The signals are to be regenerated in amplitude and time

Table 3- 1 Maximum cable length of a bus segment

Transmission rate	Max. cable length of a bus segment (in m)
9.6 to 187.5 kbps	1000
500 kbps	400
1.5 Mbps	200
3 to 12 Mbps	100

Rules

If you set up a PROFIBUS network with RS 485 repeaters:

- The number of RS 485 repeaters in series must be configured in STEP 7.
- Up to nine RS 485 repeaters may be connected in series.
- The maximum cable length between two nodes with RS 485 repeater may not exceed the values listed in the table below.

Table 3-2 Maximum cable length between two RS 485 repeaters

Transmission rate	Maximum cable length between 2 nodes (in m) with RS 485 repeater
9.6 to 187.5 kbps	10000
500 kbps	4000
1.5 Mbps	2000
3 to 12 Mbps	1000

3.2 Design of the RS 485 repeater

The following table shows the design and functions of the RS 485 repeater.

Table 3- 3 Design and functions of the RS 485 repeater

Design of the repeater	no.	Function
<p>The diagram shows the front panel of a Siemens RS 485 repeater. It features a power supply section at the top with terminals L+, M, PE, and M5.2. Below this are two sets of bus terminals, each with a shield clamp and four signal terminals (A1, B1, A1', B1' for segment 1 and A2, B2, A2', B2' for segment 2). The panel includes two sets of terminating switches (S1 and S2), two LEDs (5 and 7), and a mode selector (MODE) with PG, OFF, and OP positions. A 24V DC supply terminal is also present. At the bottom, there is a mounting slide and a PG/OP interface for bus segment 1.</p>	①	Connection for the RS 485 repeater power supply (pin "M5.2" is the ground reference, if you want to measure the voltage difference between terminals "A2" and "B2").
	②	Shield clamp for the strain relief and grounding of the bus cable of bus segments 1 or 2
	③	Terminals for the bus cable of bus segment 1
	④	Switches for terminating resistance for bus segment 1
	⑤	LED for bus segment 1
	⑥	OFF switch (= isolate bus segments from each other, for example, for commissioning)
	⑦	LED for bus segment 2
	⑧	Switches for terminating resistance for bus segment 2
	⑨	LED 24 V supply voltage
	⑩	Terminals for the bus cable of bus segment 2
	⑪	Slide for mounting and removing the RS 485 repeater on the standard mounting rail
	⑫	Interface for PG/OP on bus segment 1

Note

Terminal M 5.2 of the power supply serves as ground reference for signal measurements in the event of a fault and should not be wired.

Description

3.2 Design of the RS 485 repeater

Installation

4.1 Installing and uninstalling the RS 485 repeater

Overview

You can install the RS 485 repeater as follows:

- On an S7-300 mounting rail
- On a standard mounting rail (order number 6ES5710-8MA..)

Installation on an S7-300 mounting rail

To install the RS 485 repeater on an S7-300 mounting rail, the catch on the rear of the RS 485 repeater must first be removed (see the following figure):

1. Insert a screwdriver below the tongue of the catch (1) and
2. Push the screwdriver towards the rear of the module (2). Hold the screwdriver in this position!
Result: The catch of the RS 485 repeater is released.
3. Using your free hand lift the catch up as far as it will go and then remove the catch (3).
Result: The catch is removed from the RS 485 repeater.
4. Fit the RS 485 repeater into the S7300 mounting rail (4).

4.1 Installing and uninstalling the RS 485 repeater

5. Push it towards the back as far as it will go (5).
6. Tighten the securing screw with a torque of 80 to 110 Ncm (6).

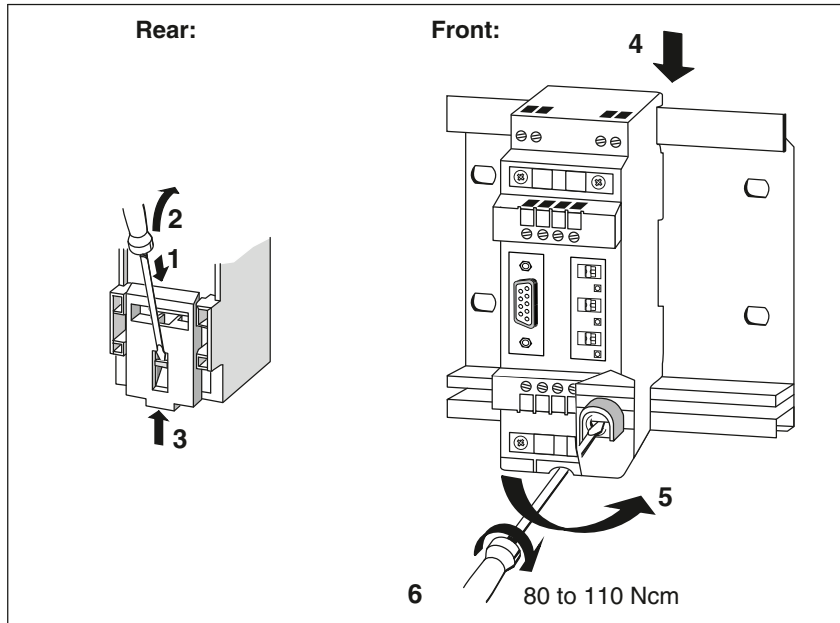

Figure 4-1 Installing the RS 485 repeater on an S7-300 mounting rail

Removing the repeater from an S7-300 mounting rail

To remove the RS 485 repeater from the S7-300 mounting rail:

1. Loosen the fixing screw of the RS 485 repeater (1) and
2. Pull the RS 485 repeater up and out (2).

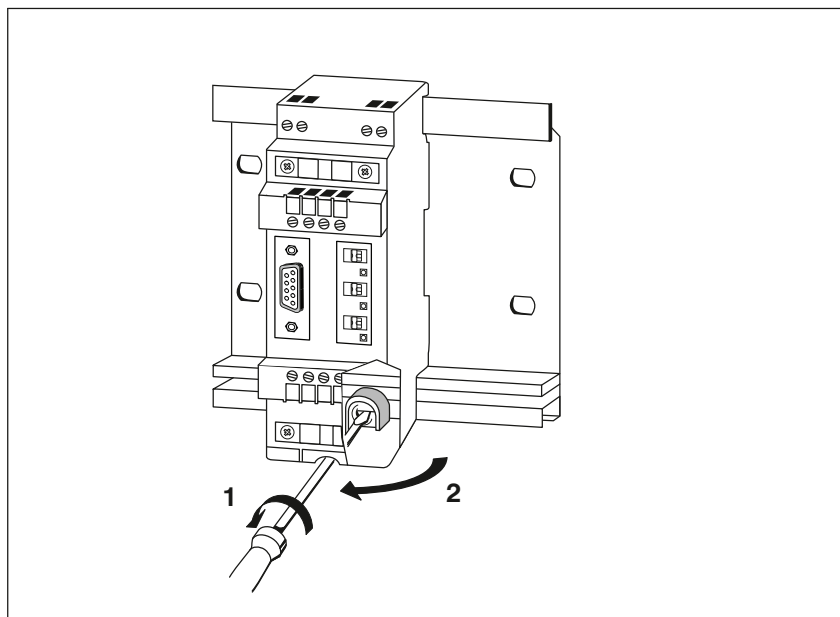

Figure 4-2 Removing the RS 485 repeater from the S7-300 mounting rail

Installation on a standard mounting rail

To be able to install the repeater on a standard mounting rail, the catch must be present on the rear of the RS 485 repeater:

1. Fit the RS 485 repeater into the standard mounting rail from above and
2. Push it towards the back until the catch locks it in place.

Removal from the standard mounting rail

To remove the RS 485 repeater from the standard mounting rail:

1. Press down the catch on the bottom of the RS 485 repeater using a screwdriver and
2. Pull the RS 485 repeater upwards and out to remove it from the standard mounting rail.

Connecting

5.1 RS 485 Repeater in ungrounded and grounded operation

Grounded or ungrounded

The RS 485 repeater is

- Grounded, if all other nodes on the bus segment are also operated on ground potential
- Ungrounded, if all other nodes in the bus segment are operated on ungrounded potential

Note

Bus segment 1 is referenced to ground if you connect a PG to the PG/OP socket of the RS 485 repeater. The bus segment is grounded because the MPI in the PG is grounded, and the PG/OP socket of the RS 485 repeater is connected internally with bus segment 1.

Grounded operation of the RS 485 Repeater

For grounded operation of the RS 485 repeater, you must bridge terminals "M" and "PE" on the top of the RS 485 repeater.

Ungrounded operation of the RS 485 repeater

For ungrounded operation of the RS 485 repeater, do not interconnect "M" and "PE" on the top of the RS 485 repeater. In addition, the supply voltage to the RS 485 repeater must be ungrounded.

Wiring diagram

In a repeater configuration with ungrounded reference potential (ungrounded operation), any interference currents and static charges are discharged to the protective conductor by means of an RC network integrated in the repeater (refer to the figure below).

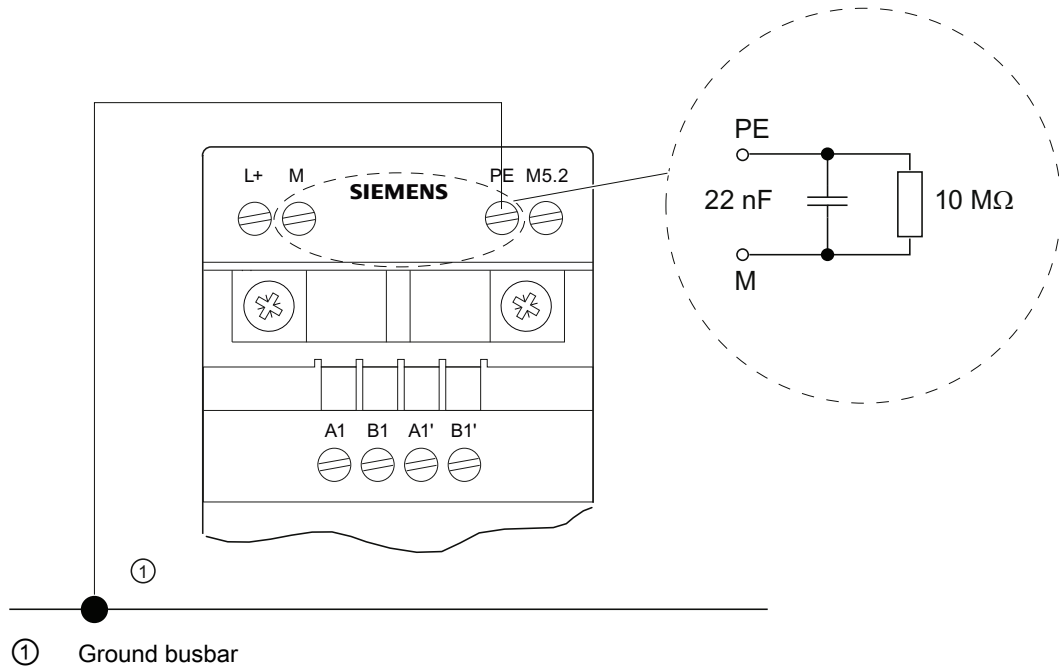

Electrical isolation between bus segments

Bus segments 1 and 2 are electrically isolated. The PG/OP interface is connected internally to the port for bus segment 1. The figure below shows the front panel of the RS 485 repeater.

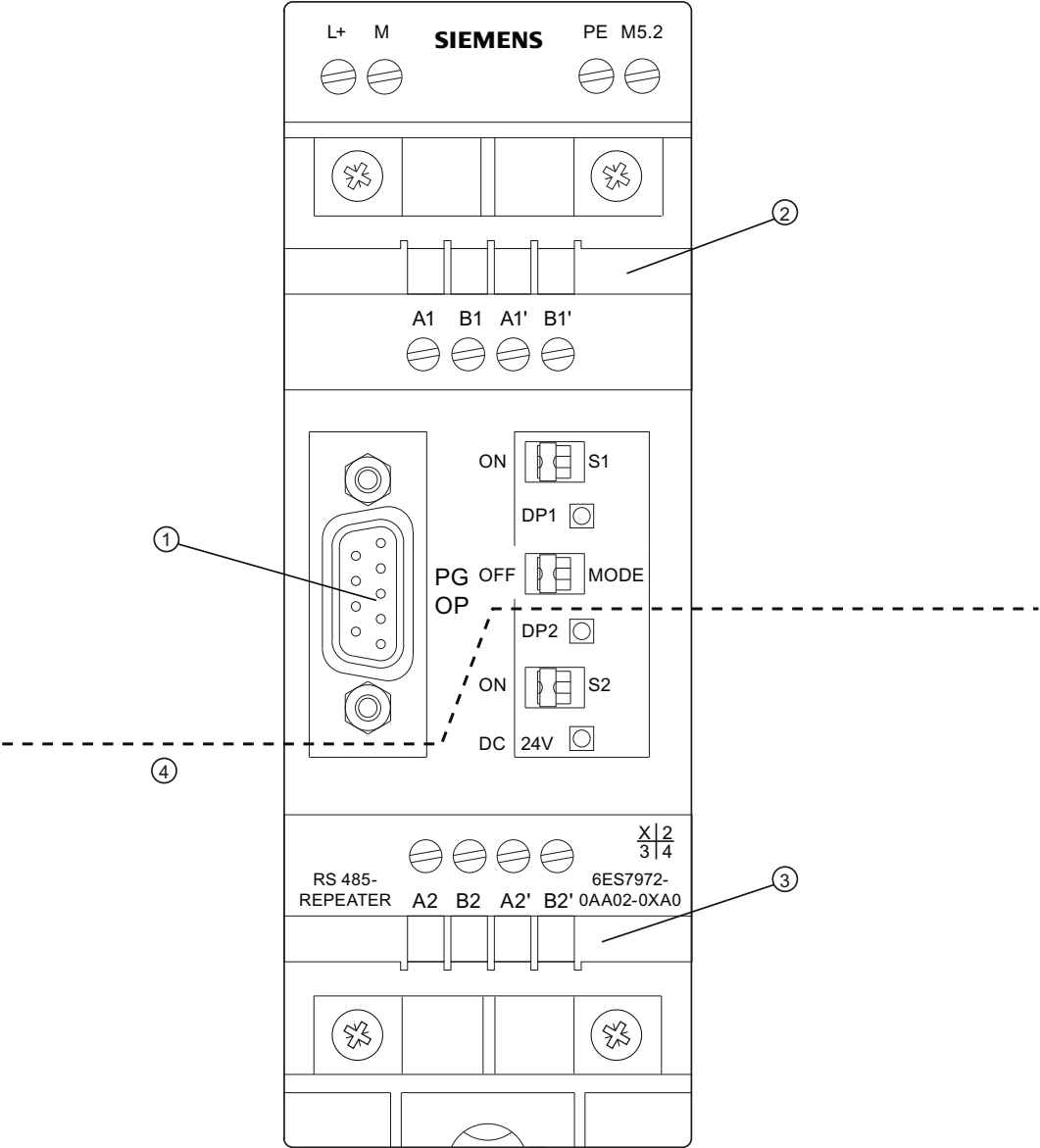

- ① PG/OP interface
- ② Terminals for bus segment 1
- ③ Terminals for bus segment 2
- ④ Electrical isolation

Amplification of bus signals

The amplification of the bus signals takes place between the port for bus segment 1 or the PG/OP interface and the port for bus segment 2.

5.2 Connecting the power supply

Cable type

To connect the 24 V DC power supply, use flexible cables with a cross section of 0.25 mm² to 2.5 mm² (AWG 26 to 14).

Connecting the power supply

To connect the power supply of the RS-485 repeater:

- Strip the insulation from the cable for the 24 V DC power supply.
- Connect the cable to terminals "L+", "M" and "PE".

5.3 Connecting the bus cable

Connecting the PROFIBUS cable

Connect the PROFIBUS cable to the RS 485 repeater, as follows:

1. Cut the PROFIBUS cable to the required length.
2. Strip the PROFIBUS cable as shown in the figure.

The braid shield must be folded back on to the cable. Only then can the shield clamp serve as strain relief and as the shield contact.

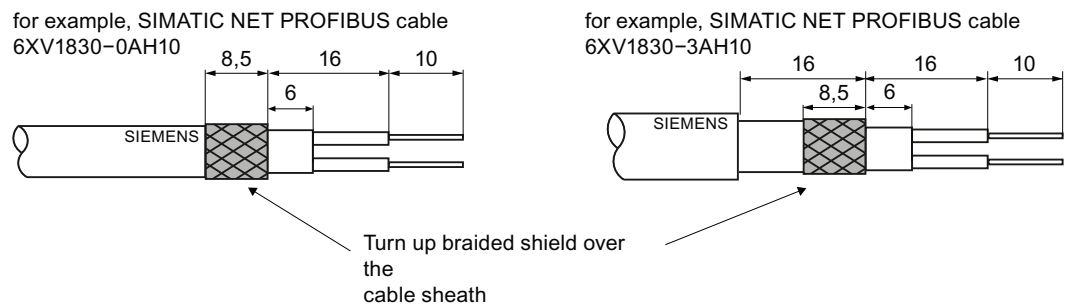
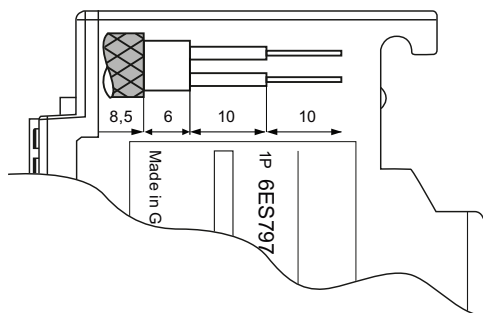

Figure 5-1 Stripping length for connecting to the RS 485 repeater

1. Connect the PROFIBUS cable to the RS 485 repeater:
Connect the same wires (green/red for the PROFIBUS cable) to the same terminal A or B (in other words, always connect terminal A with a green wire and terminal B with a red wire or vice versa).
 2. Tighten the shield clamps so that the shield makes good contact with the clamp.
- You can also find the stripping length printed on the RS 485 repeater:



SIMATIC NET PROFIBUS cables

You can find an overview of the PROFIBUS cables and their mechanical and electrical properties in the PROFIBUS system manual on the Internet (<http://support.automation.siemens.com/WW/view/en/35222591>).

5.4 Configuration options with the RS 485 repeater

Overview

The following section explains the configurations in which you can use the RS 485 repeater:

- Bus segment 1 and bus segment 2 terminated on the RS 485 repeater.
- Bus segment 1 terminated on the RS 485 repeater and bus segment 2 looped through on the RS 485 repeater.
- Bus segment 1 and bus segment 2 looped through on the RS 485 repeater.

Terminating resistor on/off

the following figure shows the setting for the terminating resistor:

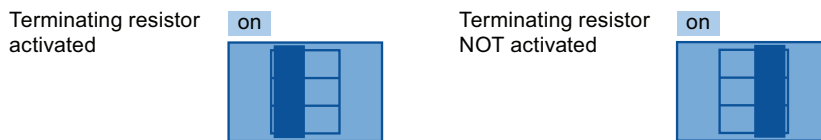

Figure 5-2 Setting of the terminating resistor

Bus segments 1 and 2 terminated

The following figure shows how to connect the RS 485 repeater to the ends between two bus segments:

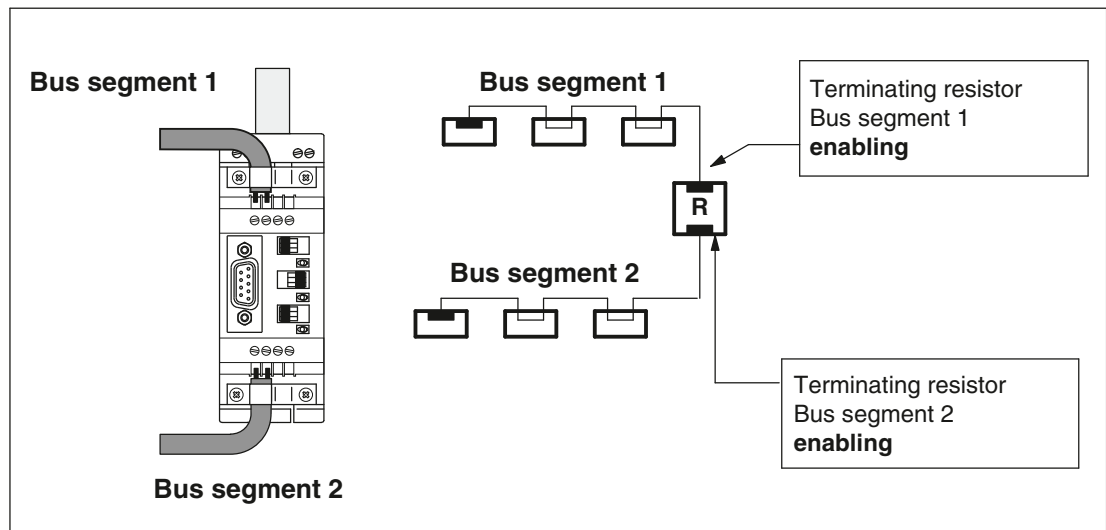

Figure 5-3 Connecting two bus segments to the RS 485 repeater

Bus segment 1 terminated, bus segment 2 looped through

The following figures show how to couple two bus segments using an RS 485 repeater. One bus segment is looped through.

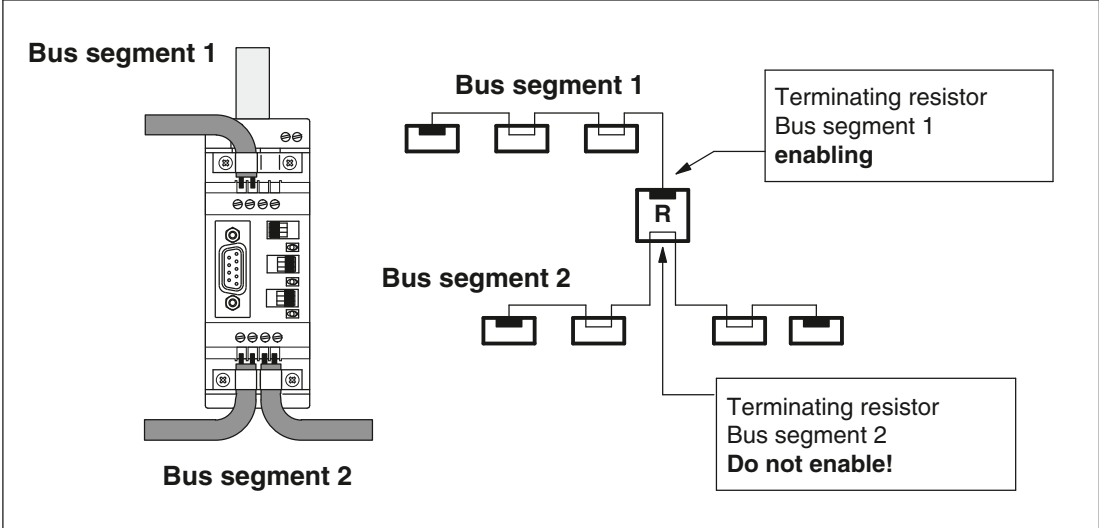

Figure 5-4 Connecting two bus segments to the RS 485 repeater

Bus segments 1 and 2 looped through

The following figures show how to couple two bus segments using an RS 485 repeater. Each bus cable is looped through on the RS 485 repeater.

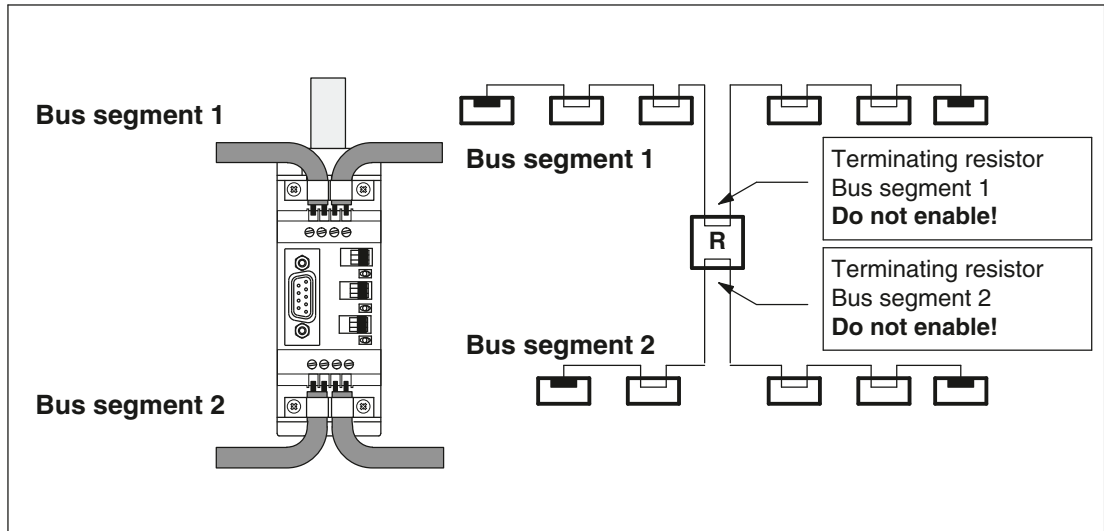

Figure 5-5 Connecting two bus segments to the RS 485 repeater

Note

When you turn off the power supply of a complete bus segment, the terminating resistors of the connected nodes are also without power supply. This can lead to disruptions or undefined signal states in this bus segment that are not recognized by the RS 485 repeater and can then lead to problems in the other bus segment.

Whenever possible, we recommend the following procedure:

- Alternative 1:
Disconnect the two bus segments before turning off the power supply using switch 6 (refer to chapter Design of the RS 485 Repeater) on the repeater (set to "OFF").
- Alternative 2:
Connect the RS 485 repeater to the power supply of the bus segment to be turned off so that the repeater is also turned off. In this case, make sure that the RS 485 repeater is not at the end of the previous bus segment, since the RS 485 repeater then acts as the terminator which has no effect if there is no power supply. If this solution is required, use a PROFIBUS terminator with a permanent power supply downstream from the RS 485 repeater.
- Alternative 3:
If you want the RS 485 repeater to retain its power supply, use PROFIBUS terminators to terminate the bus segment you want to turn off since these also require a permanent power supply. You require 1 terminator if the bus segment to be turned off ends at the RS 485 repeater, otherwise you require 2 terminators.

See also

Design of the RS 485 repeater (Page 11)

Technical data

6.1 General technical data

6.1.1 Standards and approvals

Introduction

Contents of general technical data:



- The standards and test values that the S7-300 automation system and its associated components comply with and satisfy.
- The test criteria that were used for the test.

Note

Information on the nameplate

You will find the current markings and approvals on the type plate of the respective components.

Safety guidelines

 WARNING
<p>Personal injury and damage to property may occur.</p> <p>In potentially explosive environments, there is a risk of injury or damage if you disconnect any connectors while the S7-300 is in operation.</p> <p>Always isolate the S7-300 operated in such areas before you disconnect and connectors.</p>
 WARNING
<p>Explosion hazard</p> <p>Components may no longer qualify for Class I, Div. 2 if they are replaced.</p>
 WARNING
<p>This S7-300 modules are only suitable for use in Class I, Div. 2, Group A, B, C, D, or in non-hazardous areas.</p>

Test symbols and their significance

The test symbols and their meaning are described in the following section.

CE Label



The S7-300 automation system satisfies the requirements and protection goals of the following EC directives, and conforms with the harmonized European standards (EN) for programmable logic controllers announced in the Official Journals of the European Community:

- 2006/95/EC "Electrical Equipment Designed for Use within Certain Voltage Limits" (Low-Voltage Directive)
- 2004/108/EC "Electromagnetic Compatibility" (EMC Directive)
- 94/9/EC "Equipment and protective systems intended for use in potentially explosive atmospheres" (Explosion Protection Directive)

The EC declaration of conformity is held on file available to competent authorities at:

Siemens AG
Automation & Drives Group
Industry Sector I IA AS R&D DH A
P.O. Box 1963
92209 Amberg, Germany

You can also download this under the keyword "Declaration of conformity" on the Internet.

UL certification



Underwriters Laboratories Inc. complying with

- UL 508 (Industrial Control Equipment)

CSA approval



Canadian Standards Association to

- C22.2 No. 142 (Process Control Equipment)

or

cULus approval



Underwriters Laboratories Inc. complying with

- UL 508 (Industrial Control Equipment)
- CSA C22.2 No. 142 (Process Control Equipment)

or

cULus HAZ. LOC. - approval



HAZ. LOC.

Underwriters Laboratories Inc., complying with

- UL 508 (Industrial Control Equipment)
- UL 1604 (Hazardous Location)
- CSA C22.2 No. 142 (Process Control Equipment)
- CSA C22.2 No. 213 (Hazardous Location)

APPROVED for use in
Class I, Division 2, Group A, B, C, D Tx;
Class I, Zone 2, Group IIC Tx

FM approval



Factory Mutual Research (FM) in accordance with
Approval Standard Class Number 3611, 3600, 3810
APPROVED for use in

Class I, Division 2, Group A, B, C, D Tx;
Class I, Zone 2, Group IIC Tx

6.1 General technical data

ATEX approval



In accordance with EN 60079-15 (Electrical Apparatus for Potentially Explosive Atmospheres; Type of Protection "n") and EN 60079-0 (Electrical apparatus for potentially explosive gas atmospheres - Part 0: General Requirements)



II 3 G Ex nA II T4..T6

Marking for Australia and New Zealand



The S7-300 automation system satisfies requirements of standards to AS/NZS CISPR 16.

IEC 61131

The S7-300 automation system satisfies requirements and criteria to IEC 61131-2 (Programmable Controllers, Part 2: Equipment requirements and tests).

Marine approval

Classification societies:

- ABS (American Bureau of Shipping)
- BV (Bureau Veritas)
- DNV (Det Norske Veritas)
- GL (Germanischer Lloyd)
- LRS (Lloyds Register of Shipping)
- Class NK (Nippon Kaiji Kyokai)

Use in industrial environments

SIMATIC products are designed for industrial applications.

Table 6- 1 Use in industrial environments

Field of application	Noise emission requirements	Noise immunity requirements
Industry	EN 61000-6-4: 2007	EN 61000-6-2: 2005

Use in residential areas

Note

The S7-300 is designed for use in industrial areas; using it in residential areas could disturb radio and TV reception.

To operate an S7-300 in a residential area, its RF emission must comply with Limit Value Class B to EN 55011.

Suitable measures for achieving the required Class B radio interference level include, for example:

- S7-300 installation in grounded switch cabinets / cubicles
- Use of noise filters in the supply lines

6.1.2 Electromagnetic Compatibility

Definition

Electromagnetic compatibility (EMC) is the ability of an electrical installation to function satisfactorily in its electromagnetic environment without interfering with that environment.

The S7-300 modules also satisfy requirements of EMC legislation for the European domestic market. Compliance of the S7-300 system with specifications and directives on electric design is prerequisite.

Pulseshaped disturbance

The table below shows the EMC compatibility of S7 modules in areas subject to pulse-shaped disturbance.

Pulse-shaped disturbance	Test voltage	corresponds with degree of severity
Electrostatic discharge according to IEC 61000-4-2	Air discharge: ± 8 kV	3
	Contact discharge ± 4 kV	2
Burst pulses (high-speed transient disturbance) to IEC 61000-4-4.	2 kV (power supply lines)	3
	2 kV (signal lines > 3 m)	3
	1 kV (signal lines < 3 m)	
High-energy single pulse (surge) to IEC 61000-4-5 External protective circuit required (refer to operating instructions SIMATIC S7-300, CPU 31xC and CPU 31x: Installing (http://support.automation.siemens.com/WW/view/en/13008499) in Chapter "Lightning and overvoltage protection")		3
• asymmetric coupling	2 kV (power supply lines) DC with protective elements 2 kV (signal/ data line only > 3 m), with protective elements as required	
• symmetric coupling	1 kV (power supply lines) DC with protective elements 1 kV (signal/ data line only > 3 m), with protective elements as required	

Additional measures

When connecting an S7-300 system to the public network, always ensure compliance with Limit Value Class B to EN 55022.

Sinusoidal disturbance

The table below shows the EMC compatibility of S7-300 modules in areas subject to sinusoidal disturbance.

- HF radiation

HF radiation according to IEC 61000-4-3 Electromagnetic HF field, amplitude-modulated		Corresponds with degree of severity
80 MHz to 1,000 MHz; 1.4 GHz to 2 GHz	2.0 GHz to 2.7 GHz	3, 2, 1
10 V/m	1 V/m	
80% AM (1 kHz)		

- HF coupling

HF coupling according to IEC 61000-4-6	Corresponds with degree of severity
0.15 MHz to 80 MHz	3
10 V _{rms} unmodulated	
80% AM (1 kHz)	
150 Ω source impedance	

Emission of radio interference

Electromagnetic interference according to EN 55016: Limit Value Class A (measured at a distance of 10 m).

Frequency	Noise emission
30 MHz to 230 MHz	< 40 dB (μV/m)Q
230 MHz to 1000 MHz	< 47 dB (μV/m)Q

Noise emission via AC mains to EN 55016: Limit value class A, Group 1.

Frequency	Noise emission
From 0.15 to 0.5 MHz	< 79 dB (μV/m)Q < 66 dB (μV/m)M
0.5 MHz to 5 MHz	< 73 dB (μV/m)Q < 60 dB (μV/m)M
5 MHz to 30 MHz	< 73 dB (μV/m)Q < 60 dB (μV/m)M

6.1 General technical data

6.1.3 Shipping and storage conditions for modules and backup batteries

Introduction

The shipping and storage conditions of S7-300 modules surpass requirements to IEC 61131-2. The data below apply to modules shipped or put on shelf in their original packing.

The modules are compliant with climatic conditions to IEC 60721-3-3, Class 3K7 (storage), and with IEC 60721-3-2, Class 2K4 (shipping.)

Mechanical conditions are compliant with IEC 60721-3-2, Class 2M2.

Shipping and storage conditions for modules

Type of condition	Permissible range
Free fall (in shipping package)	≤ 1 m
Temperature	- 40 °C to + 70 °C
Barometric pressure	1080 hPa to 660 hPa (corresponds with an altitude of -1000 m to 3500 m)
Relative humidity	10% to 95%, no condensation
Sinusoidal oscillation to IEC 60068-2-6	5 Hz to 9 Hz: 3.5 mm 9 Hz to 150 Hz: 9.8 m/s ²
Shock to IEC 60068-2-29	250 m/s ² , 6 ms, 1000 shocks

Shipment of backup batteries

Backup batteries should always be shipped in their original package. Note the regulations governing the transport of hazardous goods. The backup battery has a lithium content of approx. 0.25 g.

Storing backup batteries

Always store backup batteries in a cool and dry place. The batteries have a maximum shelf life of 5 years.

<p>⚠ WARNING</p> <p>Improper handling of backup batteries can result in injury and damage to property. Improperly handled backup batteries may explode or cause severe burns.</p> <p>Observe the following rules when handling the backup batteries of your S7-300 automation system:</p> <ul style="list-style-type: none"> • Never charge the batteries • Never heat the batteries • Never throw the batteries in an open fire • Never damage the batteries mechanically (drill, squeeze, etc.)
--

6.1.4 Mechanical and ambient climatic conditions for S7-300 operation

Operating conditions

S7-300 systems are designed for stationary use in weather-proof locations. The operating conditions surpass requirements to DIN IEC 60721-3-3.

- Class 3M3 (mechanical requirements)
- Class 3K3 (climatic requirements)

Use with additional measures

The S7-300 may not be used under the conditions outlined below without taking additional measures:

- at locations with a high degree of ionizing radiation
- in aggressive environments caused, for example, by
 - the development of dust
 - corrosive vapors or gases
 - strong electric or magnetic fields
- in installations requiring special monitoring, for example
 - elevators
 - electrical plants in potentially hazardous areas

An additional measure could be an installation of the S7-300 in a cabinet or housing.

Mechanical environmental conditions

The table below shows the mechanical environmental conditions in the form of sinusoidal oscillations.

Frequency band	Continuous	Infrequently
$10 \text{ Hz} \leq f \leq 58 \text{ Hz}$	0.0375 mm amplitude	0.75 mm amplitude
$58 \text{ Hz} \leq f \leq 150 \text{ Hz}$	0.5 g constant acceleration	1 g constant acceleration

Reducing vibrations

If your S7-300 modules are exposed to severe shock or vibration, take appropriate measures to reduce acceleration or the amplitude.

We recommend the installation of the S7-300 on damping materials (for example, rubber-bonded-to-metal mounting.)

6.1 General technical data

Test of mechanical environmental conditions

The table below provides important information with respect to the type and scope of the test of ambient mechanical conditions.

Condition tested	Test Standard	Comment
Vibration	Vibration test to IEC 60068-2-6 (sinusoidal)	Type of oscillation: Frequency sweeps with a rate of change of 1 octave/minute. 5 Hz ≤ f ≤ 9 Hz, constant amplitude 3.5 mm 9 Hz ≤ f ≤ 150Hz, constant acceleration 1 g Duration of oscillation: 10 frequency sweeps per axis at each of three vertically aligned axes
Shock	Shock, tested to IEC 60068-2-27	Type of shock: half-sine Severity of shock: 15 g peak value, 11 ms duration Direction of shock: 3 shocks in each direction (+/-) at each of three vertically aligned axes

Climatic environmental conditions

The S7-300 may be operated on following environmental conditions:

Environmental conditions	Permitted range	Comments
Temperature: horizontal mounting position: vertical mounting position:	0°C to 60°C 0°C to 40°C	-
Relative humidity	10 % to 95 %	No condensation, corresponds to relative humidity (RH) Class 2 to IEC 61131, Part 2
Barometric pressure	1080 hPa to 795 hPa	Corresponds with an altitude of -1000 m to 2000 m
Concentration of pollutants	SO ₂ : < 0.5 ppm; RH < 60 %, no condensation H ₂ s: < 0.1 ppm; RH < 60 %, no condensation	Test: 10 ppm; 4 days Test: 1 ppm; 4 days
	ISA-S71.04 severity level G1; G2; G3	-

6.1.5 Specification of dielectric tests, protection class, degree of protection, and rated voltage of S7-300

Test voltage

Proof of dielectric strength must be provided in the type test at a test voltage to IEC 61131-2:

Circuits with rated voltage V_n to other circuits or ground.	Test voltage
< 50 V	500 VDC
< 150 V	2500 VDC
< 250 V	4000 VDC

Protection class

Protection class I to IEC 60536, i.e., a protective conductor must be connected to the mounting rail!

Protection against the ingress of foreign matter and water

- Degree of protection IP 20 according to IEC 60529, i.e., protection against contact with standard probes.

No protection against the ingress of water.

6.2 Technical data the RS 485 Repeater

Technical data the RS 485 Repeater

Technical data	
Power supply	
• Rated voltage	24 VDC
• Ripple (static limit)	20.4 VDC to 28.8 VDC
Current consumption at rated voltage	
• without load on PG/OP socket	Max. 100 mA
• Load on PG/OP socket (5 V/90 mA)	Max. 130 mA
• Load on PG/OP socket (24 V/100 mA)	Max. 200 mA
Electrical isolation	yes, 500 VAC
Redundancy mode	no
Supports isochronous mode	Yes
Transmission rate (automatically detected by the repeater)	9.6 kbps, 19.2 kbps, 45.45 kbps, 93.75 kbps, 187.5 kbps, 500 kbps, 1.5 Mbps, 3 Mbps, 6 Mbps, 12 Mbps
Throughput times	
Transmission rate: 12 Mbps	3.0 T _{BIT} +80 ns
Transmission rate: 6 Mbps	2.4 T _{BIT} +80 ns
Transmission rate: 3 Mbps	2.2 T _{BIT} +80 ns
Transmission rate: 1.5 Mbps	2.1 T _{BIT} +80 ns
Transmission rate: <1.5 Mbps	0.5 T _{BIT} +80 ns
Jitter	1T = 1/48 MHz = 20.83 ns
Operating temperature	0° C to 60 °C
Storage temperature	40 °C to 70 °C
Relative humidity (operation)	95% at 25 °C
Degree of protection	IP 20
Connection system	
• Bus cables	2 terminal blocks
• Power supply	Terminal block
Connection of fiber-optic conductors	yes, via repeater adapters
Dimensions W x H x D (mm)	45 x 128 x 67
Weight (includes packaging)	350 g

Pin assignment of the sub-D connector (PG/OP socket)

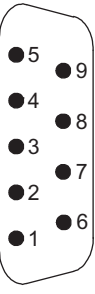
View	Pin no.	Signal name	Designation
	1	-	-
	2	M24V	Ground 24 V
	3	RxD/TxD-P	Data line B
	4	RTS	Request To Send
	5	M5V2	Data reference potential (from station)
	6	P5V2	Supply plus (from station)
	7	P24V	24 V
	8	RxD/TxD-N	Data line A
	9	-	-

Block diagram of the RS 485 Repeater

- Bus segments 1 and 2 are electrically isolated.
- Bus segment 2 and the PG/OP socket are electrically isolated.
- Signals are amplified
 - between bus segments 1 and 2
 - between PG/OP socket and bus segment 2

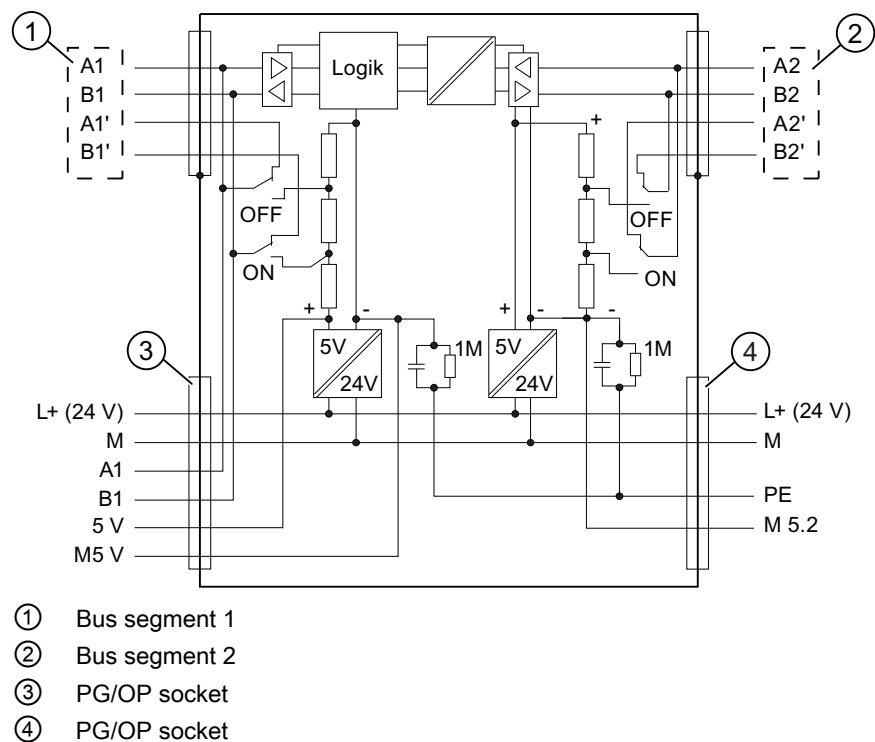

Dimension drawings

7.1 Dimension drawings

RS 485 Repeater on standard mounting rail

The figure below shows the dimensional drawing of the RS 485 repeater mounted on the standard mounting rail.

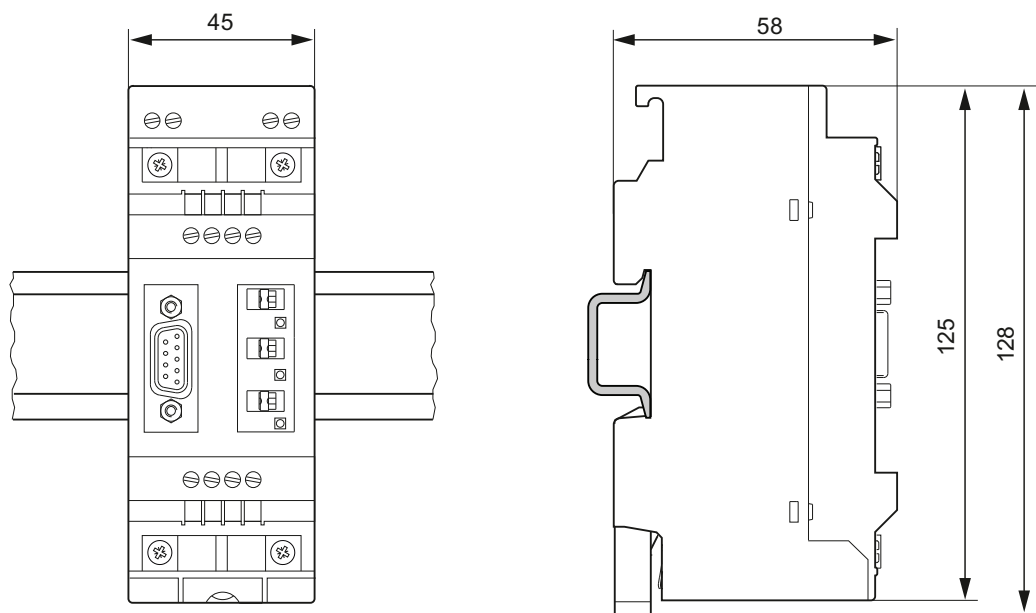

Figure 7-1 RS 485 repeater on standard mounting rail

RS 485 repeater on mounting rail

The figure below shows the dimensional drawing of the RS 485 repeater on an S7-300 mounting rail.

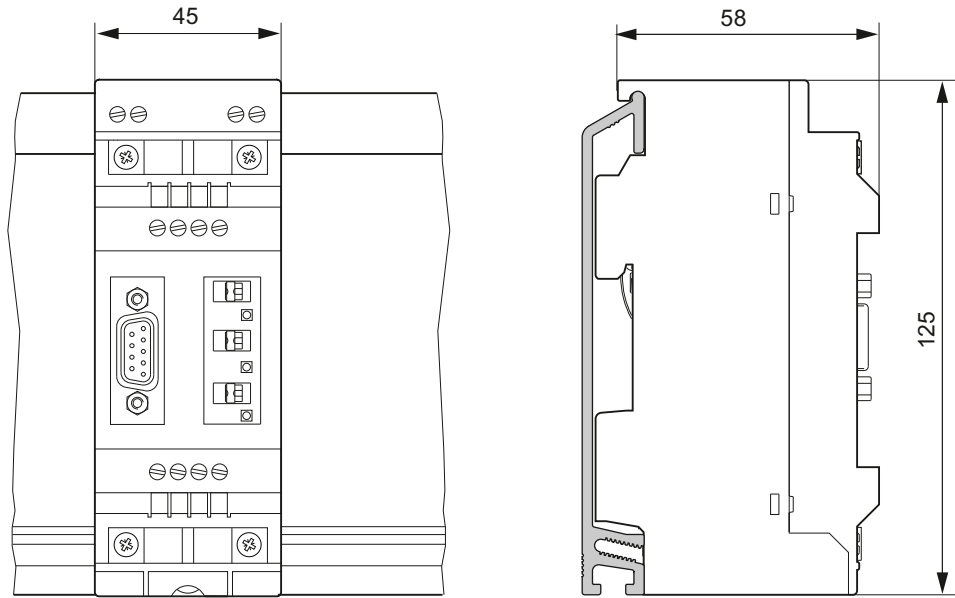

Figure 7-2 RS 485 repeater on standard rail

Glossary

Active RS 485 terminator

Separate -> terminating resistor in segments at transmission rates of 9.6 kbps to 12 Mbps.
The power supply is separate from the bus nodes.

Bus

Data transfer bus to which all nodes are connected. It has two defined ends.
In the case of PROFIBUS, the bus is a twisted-pair cable or optical fiber cable.

Bus connector

Physical connection between the node and bus cable.

Bus segment

-> Segment

The bus line between two terminating resistors forms a bus segment.

A bus segment may contain up to 32 bus nodes. Segments can be coupled, for example via RS 485 repeater or diagnostic repeater.

Bus segment

-> Segment

The bus line between two terminating resistors forms a bus segment.

A bus segment may contain up to 32 bus nodes. Segments can be coupled, for example via RS 485 repeater or diagnostic repeater.

Bus system

All nodes physically connected to a bus cable form a bus system.

Configuring

Configuring means entering a PROFIBUS configuration with all the specific parameters using, for example, STEP 7 or COM PROFIBUS.

DP master

In the DP system, the DP master conducts the communication with the DP slaves according to a defined algorithm. To do this, the DP master uses the functions for communication with the DP slaves which are defined by PROFIBUS DP.

DP slave

The DP slave can be addressed by DP masters. The DP slave provides specified functions (I/O data, diagnostics etc.) to the DP masters.

Master

A master station that is in possession of the token can send data to other nodes and request data from these (= active node.)

Master-slave process

Bus access method where only one node is → master, and all other nodes are → slaves.

Nodes

Device whose data can be sent and/or received via the bus, for example a DP master or a DP slave. This device requires a unique PROFIBUS address for this.

PROFIBUS

PROcess Field BUS, bit-serial fieldbus system standardized in IEC 61158-2 as "Type 3". The standard specifies functional, electrical and mechanical properties.

PROFIBUS is a bus system that connects PROFIBUS compatible automation systems and field devices on a cell and field level. PROFIBUS exists with the DP protocol (= Distributed Peripheral I/Os), FMS protocol (= Fieldbus Message Specification) or PA protocol (= Process Automation).

PROFIBUS address

To identify it uniquely, every bus node must be assigned a PROFIBUS address.

PCs/PGs are assigned PROFIBUS address "0".

DP master and slaves use a PROFIBUS address between 1 and 125.

PROFIBUS DP

PROFIBUS bus system with the DP protocol. DP stands for the German equivalent of distributed I/O. The main task of PROFIBUS DP is the fast, cyclic data exchange between the central DP master and the peripheral devices.

Reference potential

Reference potential for the evaluation / measuring of the voltages of participating circuits.

RS 485

Asynchronous data transmission technology for PROFIBUS DP to ANSI TIA/EIA-RS485-A.

RS 485 repeater

Device for amplifying bus signals and for linking → segments over long distances.

Slave

A slave may only exchange data with a master when requested to do so. Slaves include, for example, all DP slaves such as ET 200S, ET 200X, ET 200M etc.

Standard mounting rail

Metal rail standardized in compliance with EN 50 022.

The standard mounting rail is used for the snap-on installation of network components such as OLMs, repeaters etc.

Terminator

-> terminating resistor in segments at transmission rates of 9.6 kbps to 12 Mbps; the power supply is separate from the bus nodes.

Transmission rate

-> Transmission speed

Transmission speed

The transmission speed specifies the number of bits transmitted per second. On PROFIBUS, transmission speeds of 9.6 kbps to 12 Mbps are possible.

Index

A

- Approval, 25
 - CSA, 26
 - FM, 27
 - Marine, 28
 - UL, 26
- Use in industrial environments, 28
- Use in residential areas, 29

C

- Configuration, 22
- Connecting
 - Bus cable, 21
 - Supply voltage, 20
- Connecting the bus cable, 21
- CSA approval, 26

D

- Degree of protection IP 20, 35
- Dimension drawings, 39
- disturbance variables, 30

E

- Electrical isolation, 19
- EMV (Electromagnetic compatibility), 30
 - disturbance variables, 30
- Environmental conditions
 - Climatic, 34
 - Mechanical, 33
 - Operating condition, 33

F

- FM approval, 27

G

- grounded operation, 17

I

- IEC 61131, 28
- Insulation test, 35
- Internet, Service & Support, 6

M

- Marine approval, 28
- Mounting
 - Mounting rail for S7-300, 13
 - Standard mounting rail, 15

O

- Order number
 - 6ES7972-0AA01-0XA0, 9

P

- Protection class, 35

R

- Repeater, 7
- RS 485 Repeater, 7
 - Design, 11
 - Dimensional drawing, 39
 - Electrical isolation, 19
 - grounded operation, 17
 - Installation rules, 10
 - Pin assignment, 37
 - Properties, 9
 - Schematic circuit diagram, 37
 - Technical data, 36
 - ungrounded operation, 17

S

- Service & Support, 6
- Shipping conditions, 32
- Standards, 25
- Storage conditions, 32
- Supply voltage, 20

T

- Technical data, 36
 - EMV (Electromagnetic compatibility), 30
 - Shipping and storage conditions, 32
 - Standards and approvals, 25
- Technical Support, 5
- Terminating resistor, 22
- Test voltage, 35

U

- UL certification, 26
- ungrounded operation, 17