

# SIEMENS

## SINUMERIK

SINUMERIK 840D sl / 840Di sl /  
802D sl  
ADI4 - Analog drive interface for  
4 axes  
Manual

### Preface

---

<u>Safety information</u>	<b>1</b>
<u>System overview</u>	<b>2</b>
<u>Description</u>	<b>3</b>
<u>Hardware</u>	<b>4</b>
<u>Parameter assignment</u>	<b>5</b>
<u>Further information</u>	<b>6</b>

Valid for



Control  
SINUMERIK 840D sl/840DE sl  
SINUMERIK 840Di pl/840DiE pl  
SINUMERIK 840Di sl/840DiE sl  
SINUMERIK 802D sl

Software Version  
ADI4 system software 1.4.8

## Legal information

### Warning notice system

This manual contains notices you have to observe in order to ensure your personal safety, as well as to prevent damage to property. The notices referring to your personal safety are highlighted in the manual by a safety alert symbol, notices referring only to property damage have no safety alert symbol. These notices shown below are graded according to the degree of danger.

 <b>DANGER</b>
indicates that death or severe personal injury <b>will</b> result if proper precautions are not taken.
 <b>WARNING</b>
indicates that death or severe personal injury <b>may</b> result if proper precautions are not taken.
 <b>CAUTION</b>
with a safety alert symbol, indicates that minor personal injury can result if proper precautions are not taken.
<b>CAUTION</b>
without a safety alert symbol, indicates that property damage can result if proper precautions are not taken.
<b>NOTICE</b>
indicates that an unintended result or situation can occur if the corresponding information is not taken into account.

If more than one degree of danger is present, the warning notice representing the highest degree of danger will be used. A notice warning of injury to persons with a safety alert symbol may also include a warning relating to property damage.

### Qualified Personnel

The product/system described in this documentation may be operated only by **personnel qualified** for the specific task in accordance with the relevant documentation for the specific task, in particular its warning notices and safety instructions. Qualified personnel are those who, based on their training and experience, are capable of identifying risks and avoiding potential hazards when working with these products/systems.

### Proper use of Siemens products

Note the following:

 <b>WARNING</b>
Siemens products may only be used for the applications described in the catalog and in the relevant technical documentation. If products and components from other manufacturers are used, these must be recommended or approved by Siemens. Proper transport, storage, installation, assembly, commissioning, operation and maintenance are required to ensure that the products operate safely and without any problems. The permissible ambient conditions must be adhered to. The information in the relevant documentation must be observed.

### Trademarks

All names identified by ® are registered trademarks of the Siemens AG. The remaining trademarks in this publication may be trademarks whose use by third parties for their own purposes could violate the rights of the owner.

### Disclaimer of Liability

We have reviewed the contents of this publication to ensure consistency with the hardware and software described. Since variance cannot be precluded entirely, we cannot guarantee full consistency. However, the information in this publication is reviewed regularly and any necessary corrections are included in subsequent editions.

# Preface

## Structure of the manual

### SINUMERIK® Documentation

The SINUMERIK documentation is organized in 3 parts:

- General documentation
- User documentation
- Manufacturer/Service Documentation

Information on the following topics is available at <http://www.siemens.com/motioncontrol/docu>:

- Ordering documentation  
Here you can find an up-to-date overview of publications.
- Downloading documentation  
Links to more information for downloading files from Service & Support.
- Researching documentation online  
Information on DOConCD and direct access to the publications in DOConWEB.
- Compiling individual documentation on the basis of Siemens contents with the My Documentation Manager (MDM), refer to <http://www.siemens.com/mdm>.  
My Documentation Manager provides you with a range of features for generating your own machine documentation
- Training and FAQs  
Information on the range of training courses and FAQs (frequently asked questions) are available via the page navigation

### Target group

This documentation is intended for manufacturers of machine tools, particularly:

- Project engineers, electricians and installers
- Maintenance and service personnel

### Benefits

The information in this manual facilitates installation and connection of the SINUMERIK 840D numerical control in the control cabinet.

## Standard scope

This documentation only describes the functionality of the standard version. Extensions or changes made by the machine manufacturer are documented by the machine manufacturer.

Other functions not described in this documentation might be executable in the control. However, no claim can be made regarding the availability of these functions when the equipment is first supplied or in the event of servicing.

For the sake of simplicity, this documentation does not contain all detailed information about all types of the product and cannot cover every conceivable case of installation, operation, or maintenance.

## Technical Support

If you have any technical questions, please contact our hotline:

	<b>Europe/Africa</b>
<b>Phone</b>	+49 180 5050 222
<b>Fax</b>	+49 180 5050 223
0.14 €/min. from German landlines, max. 0.42 €/min for calls from a mobile phone	
<b>Internet</b>	<a href="http://www.siemens.com/automation/support-request">http://www.siemens.com/automation/support-request</a>

	<b>America</b>
<b>Phone</b>	+1 423 262 2522
<b>Fax</b>	+1 423 262 2200
<b>E-mail</b>	<a href="mailto:techsupport.sea@siemens.com">mailto:techsupport.sea@siemens.com</a>

	<b>Asia/Pacific</b>
<b>Phone</b>	+86 1064 757575
<b>Fax</b>	+86 1064 747474
<b>E-mail</b>	<a href="mailto:support.asia.automation@siemens.com">mailto:support.asia.automation@siemens.com</a>

---

### Note

For technical support telephone numbers for different countries, go to:

<http://www.automation.siemens.com/partner>

---

## Questions about the documentation

If you have any questions (suggestions, corrections) regarding this documentation, please fax or e-mail us at:

Fax: +49 9131 98 2176

E-mail: <mailto:docu.motioncontrol@siemens.com>

A fax form is available in the appendix of this document.

## **SINUMERIK Internet address**

<http://www.siemens.com/sinumerik>

## **EC Declaration of Conformity**

The EC Declaration of Conformity for the EMC Directive can be found/obtained:

- On the Internet: <http://support.automation.siemens.com>  
under product/order number 15257461
- From the relevant regional office of the I DT MC division of Siemens AG

## **Convention**

Throughout this document, the term "Control Unit" is also used for product designations NCU 7x0, provided that the technical conditions described are applicable to all variants.



# Table of contents

	<b>Preface .....</b>	<b>3</b>
<b>1</b>	<b>Safety information.....</b>	<b>9</b>
1.1	Danger notices .....	9
1.2	ESD information.....	10
1.3	Safe isolation to EN 61800-5-1 .....	11
1.4	RI suppression measures .....	12
<b>2</b>	<b>System overview.....</b>	<b>15</b>
<b>3</b>	<b>Description.....</b>	<b>17</b>
3.1	Properties.....	17
3.2	Essential features .....	17
3.3	Order number and firmware version .....	17
3.4	Boundary conditions .....	18
<b>4</b>	<b>Hardware.....</b>	<b>19</b>
4.1	Overview of connections .....	19
4.2	Interface description.....	20
4.2.1	Interface overview .....	20
4.2.2	Interface (X1): External power supply.....	20
4.2.3	Interface (X2): PROFIBUS DP .....	21
4.2.4	Interface (S2): PROFIBUS address.....	22
4.2.5	Interface (X3): Analog setpoint interface .....	22
4.2.6	Interfaces (X4-1/X4-2/X5-1/X5-2): Encoder interfaces .....	24
4.2.7	Interface (X6-1): Digital outputs .....	28
4.2.8	Interface (X6-2): Digital inputs .....	31
4.2.9	Interface (H1/H2): Module status .....	34
4.3	Control cabinet installation.....	34
4.4	Power supply.....	35
4.5	Grounding .....	37
4.6	Dimension drawing .....	38
4.7	Technical data.....	39
<b>5</b>	<b>Parameter assignment.....</b>	<b>41</b>
5.1	Boundary conditions of ADI4 DP slave.....	41
5.2	Preconditions, SINUMERIK 802D sl.....	41
5.3	Preconditions, SINUMERIK 840Di sl.....	41
5.4	Preconditions, SINUMERIK 840D sl.....	42
5.5	PROFIBUS DP parameter assignment.....	43
5.5.1	Parameter assignment sequence .....	43

5.5.2	Inserting an ADI4 DP slave in the configuration .....	44
5.6	PROFIBUS parameters for SINUMERIK 802D sl.....	44
5.7	PROFIBUS parameters.....	45
5.7.1	Parameter components.....	45
5.7.2	PROFIBUS address .....	45
5.7.3	Message frame type.....	46
5.7.4	I/O addresses.....	51
5.7.5	Consistency.....	51
5.8	Function parameters for SINUMERIK 802D sl.....	52
5.9	Function parameters .....	52
5.9.1	Encoder type .....	53
5.9.2	Unipolar spindle or unipolar motor .....	55
5.9.3	Shutdown ramp .....	56
5.9.4	Shutdown delay.....	56
5.9.5	Tolerable sign-of-life failures .....	57
5.9.6	Reserved bits for fine resolution .....	57
5.9.7	611U conformant mode.....	58
5.9.8	Homing using encoder zero mark.....	59
5.9.9	Homing using external zero mark .....	60
5.9.10	Boundary conditions.....	61
5.10	Parameterization of the DP communication.....	62
5.10.1	Parameter assignment of the equidistant cyclic DP communication .....	62
5.10.2	Activation of the equidistant DP cycle .....	63
5.10.3	Equidistant master cyclic component TDX .....	64
5.10.4	Equidistant DP cycle TDP .....	66
5.10.5	DP cycle TDP .....	67
5.10.6	Master application cycle TMAPC .....	69
5.10.7	Actual value acquisition Ti.....	72
5.10.8	Setpoint acceptance To .....	74
5.10.9	Alignment .....	75
5.10.10	Boundary conditions.....	78
<b>6</b>	<b>Further information .....</b>	<b>81</b>
6.1	Wiring of drive ready signals .....	81
6.2	Supported SSI encoder formats.....	81
6.3	Linear encoder with distance-coded zero marks / reference marks .....	82
	<b>Index.....</b>	<b>87</b>





# Safety information

# 1

## 1.1 Danger notices

The following notices are intended firstly for your personal safety and secondly to prevent damage occurring to the product described or any connected devices and machines. Non-observance of the warnings can result in severe personal injury or property damage.

 <b>DANGER</b>
<p>Only appropriately qualified personnel may commission/start-up SINUMERIK equipment.</p> <p>The personnel must take into account the information provided in the technical customer documentation for the product, and be familiar with and observe the specified danger and warning notices.</p> <p>When electrical equipment and motors are operated, the electrical circuits automatically conduct a dangerous voltage.</p> <p>When the system is operating, dangerous axis movements may occur throughout the entire work area.</p> <p>A potential fire hazard exists due to the energy being transferred in the equipment and the work materials used.</p> <p>All work on the electrical system must be performed after the system has been switched off and disconnected from the power supply.</p>

 <b>DANGER</b>
<p>Proper transportation, expert storage, installation and mounting, as well as careful operation and maintenance are essential for this SINUMERIK device to operate correctly and reliably.</p> <p>The details in the catalogs and proposals also apply to the design of special equipment versions.</p> <p>In addition to the danger and warning information provided in the technical customer documentation, the applicable national, local, and system-specific regulations and requirements must be taken into account.</p> <p>Only protective extra-low voltages (PELVs) that comply with EN 61800-5-1 can be connected to all connections and terminals between 0 and 48 V.</p> <p>Should it be necessary to test or take measurements on live equipment, then the specifications and procedural instructions defined in Accident Prevention Regulation VBG A2 must be adhered to, in particular § 8 "Permissible deviations when working on live components". Suitable electric tools should be used.</p>

 <b>WARNING</b>
Operating the equipment in the immediate vicinity (< 1.5 m) of mobile telephones with a transmitting power of > 1 W may lead to incorrect functioning of the devices. Connecting cables and signal lines should be installed so that inductive and capacitive interference does not in any way impair the automation and safety functions.

 <b>DANGER</b>
Repairs to devices that have been supplied by our company may only be carried out by SIEMENS customer service or by repair centers authorized by SIEMENS. When replacing parts or components, only use those parts that are included in the spare parts list. EMERGENCY STOP devices EN 60204-1 (VDE 0113 Part 1) must remain active in all modes of the automation equipment. Resetting the EMERGENCY STOP device must not cause an uncontrolled or undefined restart. Anywhere in the automation equipment where faults might cause physical injury or major material damage, in other words, where faults could be dangerous, additional external precautions must be taken, or facilities must be provided, that guarantee or enforce a safe operational state, even when there is a fault (e.g. using an independent limit value switch, mechanical locking mechanisms, EMERGENCY STOP devices)

## 1.2 ESD information

<b>CAUTION</b>
The modules contain electrostatically sensitive devices. Discharge yourself of electrostatic energy before touching the components. The easiest way to do this is to touch a conductive, grounded object immediately beforehand (for example, bare metal parts of control cabinet or the protective ground contact of a socket outlet).

**NOTICE****Handling ESD-modules:**

- When handling electrostatically sensitive devices, make sure that operator, workplace and packing material are properly grounded.
- Generally, electronic modules must not be touched unless work has to be carried out on them. When handling PCBs make absolutely sure that you do not touch component pins or printed conductors.
- Touch components only if:
  - You are permanently grounded via an ESD armband
  - You are wearing ESD shoes or ESD shoe-grounding-strips, if ESD flooring is available
- Modules may only be placed on electrically conductive surfaces (table with ESD top, conductive ESD foam plastic, ESD packaging bags, ESD transport containers).
- Keep modules away from visual display units, monitors or TV sets (minimum distance from screen 10 cm).
- Do not bring ESD-sensitive modules into contact with chargeable and highly-insulating materials, such as plastic, insulating table tops or clothing made of synthetic materials.
- Measurements on modules are allowed only if:
  - The measuring instrument is properly earthed (e.g., protective conductor) or
  - Before measuring with a floating measuring instrument, the probe is briefly discharged (e.g., touch the bare metal parts of the control housing).

## 1.3 Safe isolation to EN 61800-5-1

### Prerequisite

The complete system includes user interfaces (UIs) and interfaces for servicing, startup and maintenance.

#### User interfaces (UIs)

UIs are all the interfaces that are freely accessible to the machine operator without the need for tools or aids. These user interfaces provide safe isolation up to 230 V AC according to EN 61800-5-1.

### Interfaces for servicing, startup and maintenance



**DANGER**

The interfaces for servicing/installation and start-up/maintenance purposes are provided **without** protective separation.

If necessary, these interfaces can be isolated safely using a supplementary adapter (insulation voltage 230 V AC). Although these adapters are not included in the Siemens scope of delivery, you can buy these parts from your local dealer, who will be happy to advise you.

 **DANGER**

Safe isolation can only be ensured if the system configuration specified below is strictly adhered to. When installing additional components with EUIs, please make sure that the EUIs have safe isolation for at least 230 V AC.

**Note**

The components of the drive control comply with EN 61800-5-1 and contain only circuits and customer terminals with class DVC A voltages and safety isolation from circuits with dangerous voltages (PELV circuits).

## 1.4 RI suppression measures

In addition to the protective grounding of system components, special precautions must be taken to ensure safe, fault-free operation of the system. These measures include shielded signal lines, special equipotential bonding connections, and isolation and shielding measures.

### Shielded signal lines

- For the safe and smooth operation of the system, the specified cables must be used. Please refer to the chapter titled Connection.
- For digital signal transmission, the shield must have a conductive connection at both sides of the housing.

**Exception:**

Standard shielded cables grounded on one side can be used for devices from other manufacturers (printers, programming devices, etc.). However, these devices must not be connected to the controller during normal operation. However, if the system cannot operate without them, then the cable shields must be connected at both ends. Furthermore, the non-Siemens device must be connected to the controller via an equipotential bonding cable.

## Cable definitions

- Signal cables (example)
  - Data cables (Ethernet, PROFINET, DRIVE-CLiQ, sensor cables, etc.)
  - Ribbon cables for digital inputs/outputs
  - EMERGENCY OFF lines
- Power cables (example)
  - Low-voltage supply cables (230 V AC, 24 V DC, etc.)
  - Supply cables to contactors (primary and secondary circuit)

## Rules for routing cables

In order to maximize noise immunity for the complete system (controller, power section, machine) the following EMC measures must be observed:

- Signal cables and power cables must be routed at the greatest possible distance from one another.
- If necessary, signal and power cables may cross one another (if possible at an angle of 90°), but must never be laid close or parallel to one another.
- Signal cables may not be routed close to strong external magnetic fields (e.g., motors and transformers).
- Pulse-loaded HC/HV lines must always be laid completely separately from all other lines.
- If signal lines cannot be routed a sufficient distance away from other cables, they must be installed in grounded cable ducts (metal).
- The clearance (interference injection area) between the following lines must be kept to a minimum:
  - Signal line and electrical circuit signal line (twisted)
  - Signal line and associated equipotential bonding conductor
  - Equipotential bonding conductor and protective conductor (routed together)

---

### Note

For more information about interference suppression measures and connection of shielded cables, see

### References

/EMC/ EMC Installation Guide

---



## System overview

SINUMERIK 840D sl combines CNC, HMI, PLC, closed-loop control, and communication tasks within a single NCU (Numerical Control Unit).

### Components

For operation, programming, and visualization purposes, the corresponding operating software is already integrated into the CNC software for the NCU and therefore runs on the high-performance NCU multi-processor module. For increased operating performance, the SINUMERIK PCU 50.3 industrial PC can be used.

Up to four distributed OPs can be operated on one NCU/PCU. The operator panel can be installed as a Thin Client at a distance of up to 100 m.

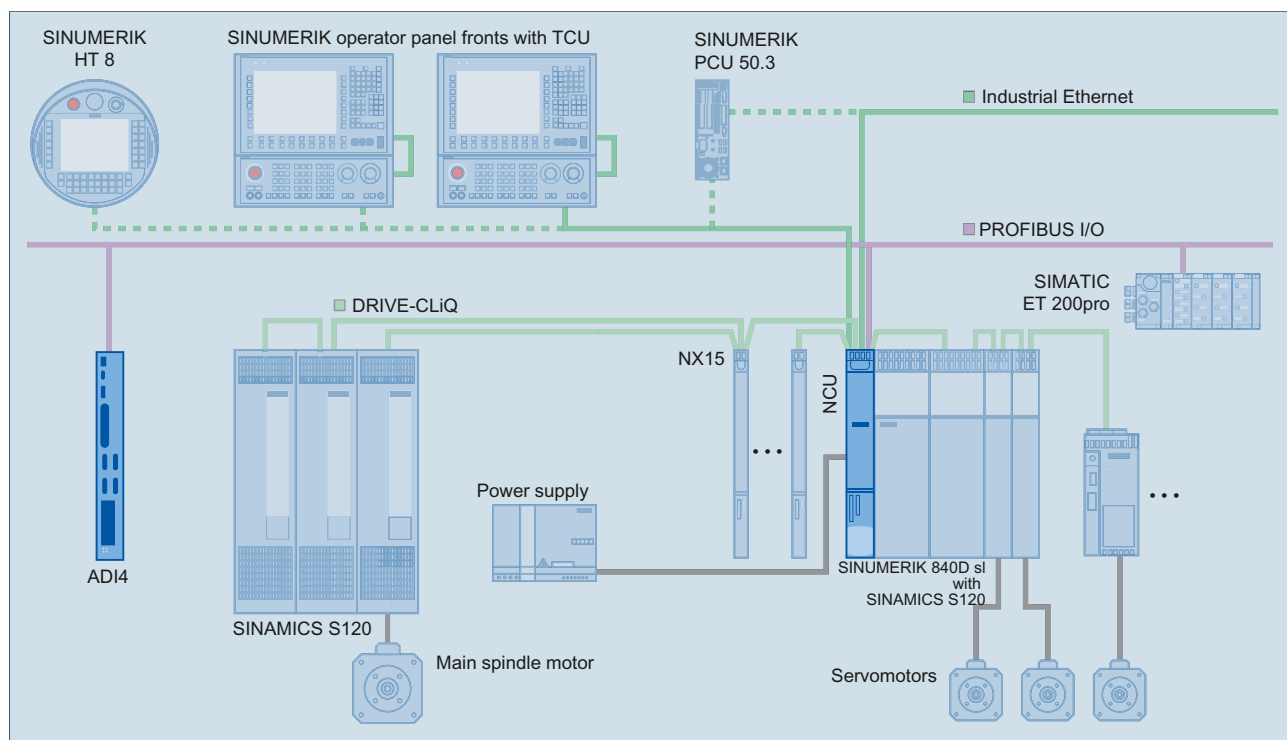

Figure 2-1 Typical topology of the SINUMERIK 840D sl complete system

The following components can be attached to the Control Unit:

- SINUMERIK operator panel front with TCU/PCU 50.3 and Machine Control Panel/Machine Push Button Panel
- SIMATIC CE panel
- SINUMERIK handheld units
- Distributed PLC I/O via PROFIBUS DP or PROFINET I/O (only applies to NCU 720.2 PN and NCU 730.2 PN)

- SINUMERIK PP 72/48 peripheral module
- SINUMERIK ADI4 (Analog Drive Interface for 4 Axes)
- SINAMICS 120 drive system
- Feed and main spindle motors
  - 1FT/1FK/1FN/1FW6/1FE1/2SP1 synchronous motors
  - 1PH/1PM asynchronous motors

With the NCU 720.2 PN and NCU 730.2 PN, the SINUMERIK 840D sl is offering integrated PROFINET functionality for the first time.

Supported:

- PROFINET CBA functionality

The CBA functionality integrated in the NCU allows users to modularize machinery and systems: Rapid real-time communication (up to 10 ms) between the controllers means that systems lend themselves better to standardization and can be reused or expanded more easily. Response to customer demands is faster and more flexible and startup is simplified and speeded up by pretesting at component level.

- PROFINET IO

As part of PROFINET, PROFINET IO is a communication concept that is used to implement modular, distributed applications. PROFINET IO is based on Industrial Ethernet and allows distributed field and I/O equipment to be connected to the central processing unit.

256 PROFINET IO devices can be operated on the NCU as an IO controller.



## Description

### 3.1 Properties

#### Properties of ADI4 module

An ADI4 module (Analog Drive Interface for 4 axes) is an interface module suitable for operating up to four drives with an analog setpoint interface and TTL/SSI encoders on an equidistant PROFIBUS-DP.

Communication between the controller and the ADI4 is performed via an ADI4-specific message frame type which, in addition to digital input/output data, also contains a message frame type for each drive specified according to a PROFIDrive profile (standard message frame 3, see Chapter "Message frame type (Page 46)"). As part of cyclic DP communication, the actual drive values (encoder values) are transferred from the ADI4 module to the controller via PROFIBUS DP, and the speed setpoints calculated by the controller are transferred to the ADI4 module.

The transferred speed setpoints are then output from the ADI4 module to the drives as analog values.

### 3.2 Essential features

#### Features of the ADI4 module

The module has the following essential features:

- PROFIBUS DP connection (maximum of 12 Mbits/s)
- 4 servo interfaces
  - Inputs: TTL/SSI encoder for incremental and absolute measuring systems
  - Bidirectional analog outputs:  $\pm 10$  V
- General and drive-specific digital input/output signals
- On-board status display via four diagnostic LEDs

To supply the module and digital outputs with power, an external voltage source (+24 VDC) is needed.

### 3.3 Order number and firmware version

#### Order number

Order no.: 6FC5211-0BA01-0AA4

### **Firmware version**

Firmware version: 1.4.8

To display the firmware version of the module, see the note on PROFIBUS address 127 in Chapter "PROFIBUS address (Page 45)".

## **3.4 Boundary conditions**

The following supplementary conditions must be taken into account for the operation of an ADI4 on the PROFIBUS DP:

- An ADI4 can only be operated on an **equidistant** PROFIBUS DP.
- An ADI4 is **not** a certified DP standard slave as defined by the PROFIDrive profile. For example, an ADI4 does not permit acyclic communication.

### **See also**

Overview of connections (Page 19)

## Hardware

### 4.1 Overview of connections

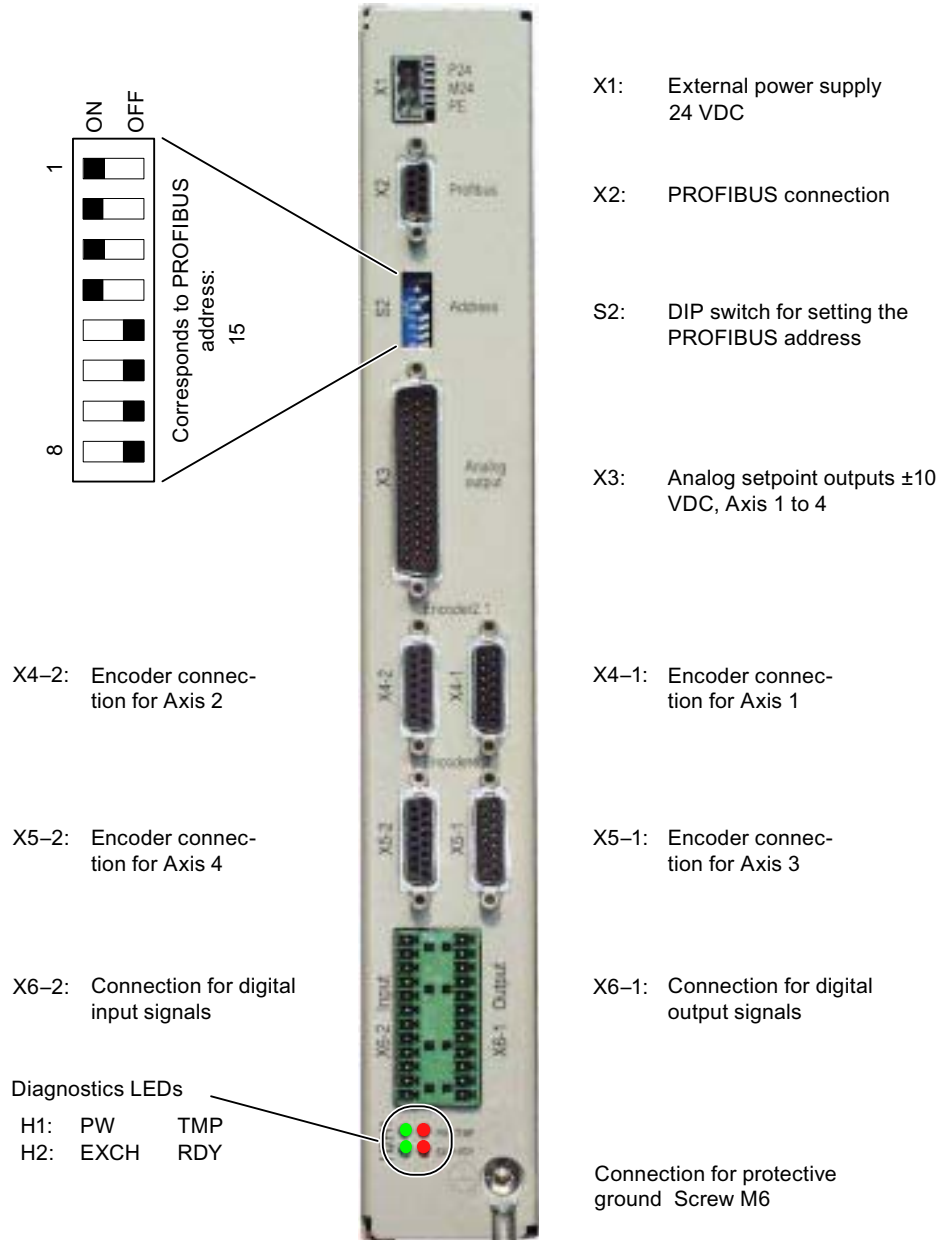

Figure 4-1 Overview of connections

## 4.2 Interface description

### 4.2.1 Interface overview

The module has the following interfaces:

Table 4- 1 Interface overview of ADI4

Interface	Designation	Type
External +24 V power supply	X1	Plug
PROFIBUS DP	X2	Socket
PROFIBUS DP address	S2	DIP switch
Analog setpoint interface	X3	Plug
Encoder connection for Axis 1	X4-1	Socket
Encoder connection for Axis 2	X4-2	Socket
Encoder connection for Axis 3	X5-1	Socket
Encoder connection for Axis 4	X5-2	Socket
Digital outputs	X6-1	Plug
Digital inputs	X6-2	Plug
Module status	H1/H2	LEDs

### 4.2.2 Interface (X1): External power supply

#### Connection

3-pin connector MSTB 2.5/3-ST-5.08 by Phoenix

#### Pin assignment

Table 4- 2 Pin assignment: External power supply (X1)

Pin	Designation	Type <sup>1)</sup>	Function
1	P24EXT1	VI	External supply for module (+24 V)
2	M24EXT1	VI	Reference for external supply
3	PE	VI	Protective conductor of the external supply

<sup>1)</sup> VI: Voltage input

#### Connection cables

The required connecting cables must be provided by the user:

Wire, conductor cross section: 1.0 - 1.5 mm<sup>2</sup> (AWG17 - AWG16)

## Supply voltage

The specifications of the supply voltage can be found in Section "Power supply (Page 35)".

## 4.2.3 Interface (X2): PROFIBUS DP

### Connection

9-pin sub D socket

### Pin assignment

Table 4- 3 Pin assignment: PROFIBUS DP (X2)

Pin	Designation	Type <sup>1)</sup>	Function
1	-	-	-
2	-	-	-
3	RxD/TxD-P	B	Receive/transmit data P (B line)
4	RTS	O	Request to Send
5	DGND	VO	Data reference potential (M5V)
6	VP	VO	Supply voltage plus (P5V)
7	-	-	-
8	RxD/TxD-N	B	Receive/transmit data N (A line)
9	-	-	-
<sup>1)</sup> VO: Voltage output O: Output B: Bidirectional			

### Connectors

- 6ES7 972-0BA41-0XA0; cable outlet 35°, without PG connection socket
- 6ES7 972-0BB41-0XA0; cable outlet 35°, with PG connection socket

### Cables

- 6XV1 830-0EH10; by the meter; without trailing capability
- 6XV1 830-3EH10; by the meter; with trailing capability

### Other technical data

Maximum possible data rate: 12 Mbits/s

### 4.2.4 Interface (S2): PROFIBUS address

#### Setting

The PROFIBUS address of the ADI4 DP slave can only be 15 or 16 for the 802D sl and is set via the S2 switch.

- PROFIBUS address 15: S2 switch, 1 to 4 set to ON
- PROFIBUS address 16: S2, only switch 5 set to ON

Table 4- 4 Meaning of switch S2

Switches	Meaning
1	PROFIBUS address: $2^0 = 1$
2	PROFIBUS address: $2^1 = 2$
3	PROFIBUS address: $2^2 = 4$
4	PROFIBUS address: $2^3 = 8$
5	PROFIBUS address: $2^4 = 16$
6	PROFIBUS address: $2^5 = 32$
7	PROFIBUS address: $2^6 = 64$
8	Not used

<b>NOTICE</b>
A newly set PROFIBUS address will only come into effect after power OFF/ON.

### 4.2.5 Interface (X3): Analog setpoint interface

#### Connection

50-pin sub D connector

#### Pin assignment

Table 4- 5 Pin assignment: Analog setpoint interface (X3)

Pin	Designation	Type <sup>1)</sup>	Function
1	SW1	VO <sup>3)</sup>	Setpoint of Axis 1 ( $\pm 10$ V)
2	BS2	VO	Reference for setpoint of Axis 2
3	SW3	VO <sup>3)</sup>	Setpoint of Axis 3 ( $\pm 10$ V)
4	BS4	VO	Reference for setpoint of Axis 4
5-13	-	-	-

Pin	Designation	Type <sup>1)</sup>	Function
14	RF1_1	K <sup>2)</sup>	"Drive enable" of Axis 1, Relay Contact 1
15	RF2_1	K <sup>2)</sup>	"Drive enable" of Axis 2, Relay Contact 1
16	RF3_1	K <sup>2)</sup>	"Drive enable" of Axis 3, Relay Contact 1
17	RF4_1	K <sup>2)</sup>	"Drive enable" of Axis 4, Relay Contact 1
18-33	-	-	-
34	BS1	VO	Reference for setpoint of Axis 1
35	SW2	VO <sup>3)</sup>	Setpoint of Axis 2 ( $\pm 10$ V)
36	BS3	VO	Reference for setpoint of Axis 3
37	SW4	VO <sup>3)</sup>	Setpoint of Axis 4 ( $\pm 10$ V)
38-46	-	-	-
47	RF1_2	K <sup>2)</sup>	"Drive enable" of Axis 1, Relay Contact 2
48	RF2_2	K <sup>2)</sup>	"Drive enable" of Axis 2, Relay Contact 2
49	RF3_2	K <sup>2)</sup>	"Drive enable" of Axis 3, Relay Contact 2
50	RF4_2	K <sup>2)</sup>	"Drive enable" of Axis 4, Relay Contact 2

1) VO Voltage output

K Relay contact

2) Max. current carrying capacity: 2 A for 150 VDC or 125 VAC

Max. number of switching cycles:

- 24 VDC, 1 A:  $10^7$

- 24 VDC, 2 A:  $10^5$

3) Max. current carrying capacity: 10 mA (RL: 1 kW - 2 kW)

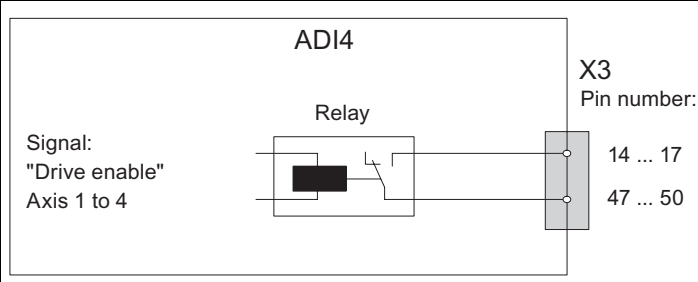

### Prefabricated cables

Order no.: 6FX2 002-3AD01-□□□□

Cable length:  $\leq 35$  m

Information regarding the length codes is provided in:

**References:** /Z/ Catalog NC Z

### Resolution of setpoint outputs

The analog setpoint outputs on the interface (X3) have the following resolution: 16-bit, including sign.

### 4.2.6 Interfaces (X4-1/X4-2/X5-1/X5-2): Encoder interfaces

#### Connection

15-pin SUB-D socket

#### Pin assignment

Pin assignment: Encoder interface of axes 1 to 4 (X4-1/X4-2/X5-1/X5-2) for incremental encoder (TTL) and absolute encoder (SSI)

Table 4- 6 Pin assignment: Encoder interface of axes 1 to 4 (X4-1/X4-2/X5-1/X5-2) for incremental encoder (TTL) and absolute encoder (SSI)

Pin	Designation <sup>1)</sup>		Type <sup>2)</sup>	Function
	Incremental	Absolute (SSI)		
1	Unassigned		-	-
2	-	CLSx	O	SSI shift clock
3	-	CLSx_N	O	SSI shift clock inverted
4	P5MS		VO	5 V DC supply voltage
5	P24SSI		VO	24 V DC supply voltage
6	P5MS		VO	5 V DC supply voltage
7	MEXT		VO	Reference for supply voltage
8	Unassigned		-	-
9	MEXT		VO	Reference for supply voltage
10	Rx_S	-	I	Zero mark signal (U <sub>a0</sub> )
11	XRx_S	-	I	Zero mark signal inverted (/U <sub>a0</sub> )
12	XBx_S	-	I	Encoder signal track B inverted (/U <sub>a2</sub> )
13	Bx_S	-	I	Encoder signal track B (U <sub>a2</sub> )
14	XAx_S	-	I	Encoder signal track A inverted (U <sub>a1</sub> )
	-	DATAx_N	I	SSI data inverse
15	Ax_S	-	I	Encoder signal track A (U <sub>a1</sub> )
	-	DATAx	I	SSI data

<sup>1)</sup> x\_ : Number of the encoder interface with X4-1=1, X4-2=2, X5-1=3, X5-2=4  
<sup>2)</sup> VO: Voltage output  
I: Signal input  
O: Signal output



## Prefabricated cables

The following preassembled cables can be used, depending on the encoder type:

- **Incremental encoder (TTL) with RS 422 and operating voltage 5 V or 24 V**

Order number (MLFB): 6FX8 002-2CD01-1□□0 (5 V)

Order number (MLFB): 6FX5 002-2CD24-1□□0 (24 V)

Information on the cable lengths can be found in the "Maximum cable lengths" section.

- **Absolute encoder with SSI**

Order number (MLFB): 6FX8 002-2CC11-□□□0

Information on the cable lengths can be found in the "Maximum cable lengths" section.

- **1FT5 motor with integrated ROD320 encoder**

Order number (MLFB): 6FX8 002-2CE02-1□□0

Cable length: Can be found in the "Maximum cable lengths" section.

Information regarding the length codes is provided in:

**References:** /Z/ Catalog NC Z

## Maximum cable lengths

The maximum cable length depends on the following two parameters:

- **Encoder supply voltage**

Table 4- 7 Encoder supply voltage

Supply voltage: 5 V DC		
Tolerance	Current consumption	Max. cable length
4.75 V - 5.25 V	$\leq 300$ mA	25 m
4.75 V - 5.25 V	$\leq 220$ mA	35 m

Supply voltage: 24 V DC		
Tolerance	Current consumption	Max. cable length
20.4 V - 28.8 V	$\leq 300$ mA	100 m
11 V - 30 V	$\leq 300$ mA	300 m

- **Transmission frequency**

Table 4- 8 Transmission frequency

Encoder type	Supply voltage	Frequency	Max. cable length
Incremental (TTL)	5 V	1 MHz	10 m
		500 kHz	35 m
Absolute (SSI)	24 V	500 kHz	150 m
	24 V	1.5 Mbit/s	10 m
		187.5 kbit/s	250 m

**Note**

If cable lengths longer than 25 m or 35 m are needed for incremental encoders, encoder types with a 24 V DC supply voltage can be used instead.

<b>CAUTION</b>
To ensure error-free transmission of encoder data, do not exceed the maximum cable lengths shown in these tables.

**Encoder supply voltages**

The encoder supply voltages must comply with the following specification:

Table 4- 9 Specification of encoder supply voltages

	Supply voltage <sup>1)</sup>	
	P5MS	P24SSI
<b>Voltage</b>		
Minimum	4.75 V	20.4 V
nominal	5 V	24 V
Maximum	5.25 V	28.8 V
<b>Ripple</b>		
Maximum	50 mVpp	3.6 Vpp
<b>Current load</b>		
Per encoder connection	0.3 A	
Maximum	1.35 A	1 A

<sup>1)</sup> P5MS: Supply voltage for encoder (+5 V DC)  
P24SSI: Supply voltage for encoder (+24 V DC)

## Connectable measuring systems

### Incremental encoder (TTL)

- Differential transmission with RS 422 and operating voltage 5 V or 24 V
  - Track A as true and inverted signal ( $U_{a1}$ ,  $/U_{a1}$ )
  - Track B as true and inverted signal ( $U_{a2}$ ,  $/U_{a2}$ )
  - Zero signal N as true and inverted signal ( $U_{a0}$ ,  $/U_{a0}$ )
- Maximum output frequency: 1.5 MHz
- Phase shift of track A to track B:  $90^\circ \pm 30^\circ$
- Current consumption: max. 300 mA
- Encoders with distance-coded zero marks/reference marks are not generally enabled.

### Absolute value encoder (SSI)

- Transmission method: Synchronous serial interface (SSI) according to RS 485 with 5 V differential signal transmission (RS 422 standard):
  - Output signal: Data as true and inverted signal
  - Input signal: Shift clock as true and inverted signal
- "Christmas tree" output format for rotary encoders
- Resolution: max. 25 bits
- Maximum transmission frequency: 1 Mbit/s
- Current consumption: max. 300 mA

## (SINUMERIK 802D sl)

- **Absolute value encoder (SSI)**

The use of absolute encoders (SSI) has **not** been released.

## (SINUMERIK 840Di sl)

- **Linear encoder with distance-coded zero marks / reference marks**

The following linear encoders with distance-coded zero marks / reference marks have been released for ADI4:

- Heidenhain: LS 476 C
- Heidenhain: LS 186 C,  
in conjunction with external pulse-shaping electronics (EXE), e.g. IBV 610

---

### Note

Encoders with SINE/COSINE signals (1 Vpp) can be connected using external pulse shaping electronics (EXE), which convert the signals to the 5 V TTL level.

---

### 4.2.7 Interface (X6-1): Digital outputs

#### Connection

Two 12-pin connectors FK-MCP 1.5/15-ST-3.81 by Phoenix

#### Pin assignment

Table 4- 10 Pin assignment: Digital output interface (X6-1)

Pin	Designation	Type 1)	Function
1	P24EXT2	VI	ext. 24 V DC supply voltage
2	Q0	DO	Digital output signal 1
3	Q1	DO	Digital output signal 2
4	Q2	DO	Digital output signal 3
5	Q3	DO	Digital output signal 4
6	DIR1	DO	Digital output signal 5 or directional signal of axis 1 <sup>3)</sup>
7	DIR2	DO	Digital output signal 6 or directional signal of axis 2 <sup>3)</sup>
8	DIR3	DO	Digital output signal 7 or directional signal of axis 3 <sup>3)</sup>
9	DIR4	DO	Digital output signal 8 or directional signal of axis 4 <sup>3)</sup>
10	RDY1	K <sup>2)</sup>	"Ready" signal of relay contact 1
11	RDY2	K <sup>2)</sup>	"Ready" signal of relay contact 2
12	MEXT2	VI	Reference of the external supply voltage

Pin	Designation	Type 1)	Function
1)	VI: Voltage input DO: Digital output (24 V) K: Relay contact		
2)	Max. current carrying capacity: 2 A for 150 V DC or 125 V AC; Max. number of operating cycles: - 24 V DC, 1 A: 10 <sup>7</sup> - 24 V DC, 2 A: 10 <sup>5</sup>		
3)	For "unipolar spindle" function (or unipolar motor)		

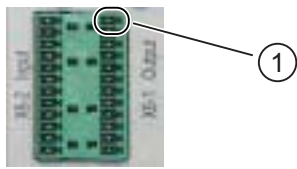
① PIN 1

**(SINUMERIK 802D sl)**

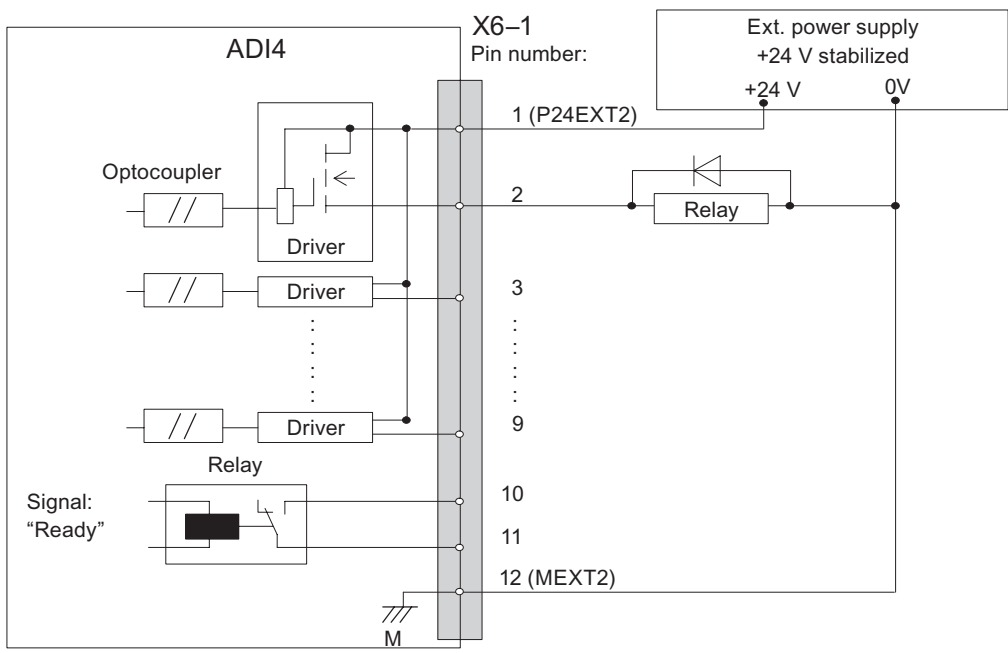
The signals from pins 2...9 are **not** available on an ADI4 module connected to SINUMERIK 802D sl.

**Supply voltage**

To supply the digital outputs with power, an external 24 V DC voltage source must be connected to X6-1, pin 1 (P24EXT2).

The reference ground of the external voltage source must be connected with X6-1, pin 15 (MEXT2).

Further data can be found in the "Technical data" section.

**Electrical specification**

Table 4- 11 Electrical specification of the digital outputs

Digital outputs	min.	Typical	max.	nominal
Voltage for high-level (V <sub>H</sub> )	V <sub>CC</sub> - 3 V	1)	V <sub>CC</sub>	24 V
Output current I <sub>OUT</sub>	-	-	500 mA	-
Voltage for low level (V <sub>L</sub> )	-	-	-	0 V
Leakage current at low level	-	50 µA	400 µA	-
Signal delay T <sub>PHL</sub> , T <sub>PLH</sub> <sup>2)</sup>	-	0.5 ms	-	-
Supply voltage of the dig. outputs 1) Typical output voltage: V <sub>CC</sub> - I <sub>OUT</sub> * R <sub>ON</sub> - 0.65 V V <sub>CC</sub> : Actual operating voltage P24EXT2 Max. output current I <sub>OUT</sub> : 500 mA Max. short-circuit current: 4 A (max. 100 µs, V <sub>CC</sub> = 24 V) Internal resistance R <sub>ON</sub> : 0.4 Ω 2) The PROFIBUS communication time as well as the application cycle time must also be taken into account. Incorrect connection causes neither high level nor destruction of the outputs.				

**General electrical properties**

- Galvanic isolation using optocouplers
- Current limitation to a maximum of 500 mA
- Protection against: short-circuit, overtemperature, and loss of ground
- Automatic disconnection in case of undervoltage

**Relay contact: "Ready" signal**

The relay contact remains/is **opened** if the module is in one of the following states:

- Initialization of the module after Power ON
- Power failure or hardware interrupt (NMI)
- No cyclic communication to the DP master
- PLL error
- Synchronization error
- Overtemperature

The relay contact is **closed** if both conditions are present:

- Module status "Ready"
- Cyclic communication with the DP master

## Connecting cable

The required connecting cables must be provided by the user:

- Supply voltage X6-1, pins 1 and 12 (P24EXT2):  
Wire, conductor cross-section of 1.5 mm<sup>2</sup> (AWG16)
- Digital outputs X6-1, pins 2...9:  
Wire, conductor cross-section 0.5 to 1.5 mm<sup>2</sup> (AWG20 - AWG16)
- Ready X6-1, pins 10 and 11:  
Wire, conductor cross-section of 1.5 mm<sup>2</sup> (AWG16)

NOTICE
The maximum length of the digital signal cable is 30 m.

## See also

Technical data (Page 39)

## 4.2.8 Interface (X6-2): Digital inputs

### Connection

Two 12-pin connectors FK-MCP 1.5/15-ST-3.81 by Phoenix

### Pin assignment

Table 4- 12 Pin assignment: Digital input interface (X6-2)

Pin	Designation	Type <sup>1)</sup>	Function
1	P24OUT	VI	24 V DC supply voltage
2	BERO1	DI	Input signal of BERO / external zero mark 1
3	BERO2	DI	Input signal of BERO / external zero mark 2
4	BERO3	DI	Input signal of BERO / external zero mark 3
5	BERO4	DI	Input signal of BERO / external zero mark 4
6	MEPU1	DI	Measuring signal, probe 1 (see "Measuring probe" below)
7	MEPU2	DI	Measuring signal, probe 2 (see "Measuring probe" below)
8	DRV1_RDY	DI	"Drive Ready" signal of axis 1
9	DRV2_RDY	DI	"Drive Ready" signal of axis 2
10	DRV3_RDY	DI	"Drive Ready" signal of axis 3
11	DRV4_RDY	DI	"Drive Ready" signal of axis 4
12	MOUT	VI	Reference of the supply voltage

4.2 Interface description

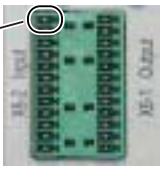
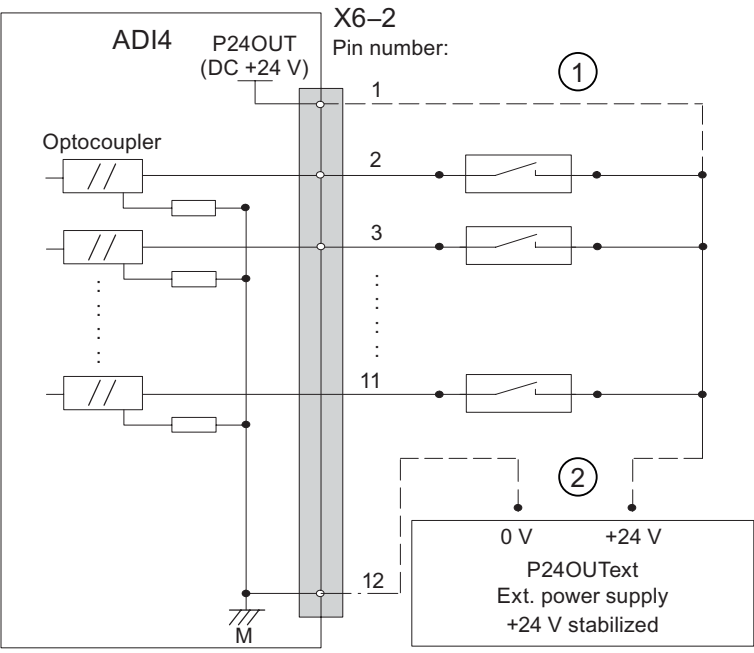
Pin	Designation	Type <sup>1)</sup>	Function
<sup>1)</sup>	VI: Voltage Input DI: Digital input (24 V)		 <p>① PIN 1</p>
			
<p>① Connection if the internal supply voltage P24OUT is used; the connection in accordance with ② is no longer required.</p> <p>② Connection if an external supply voltage P24OUText is used; the connection in accordance with ① is no longer required.</p>			

(SINUMERIK 802D sl)

On an ADI4 module in connection with SINUMERIK 802D sl, the signal: "Measuring signal, probe 2" (pin 7) is **not** available.

Internal supply voltage P24OUT

Specification of the internal supply voltage P24OUT available at X6-2, pin 1 for the digital inputs:

Table 4- 13 Specification of the supply voltage P24OUT

Voltage	
Minimum	20.4 V
Nominal	24 V



<b>Voltage</b>	
Maximum	28.8 V
<b>Ripple</b>	
Maximum	3.6 Vpp
<b>Current load</b>	
Typical	0.1 A
Maximum	1 A
<b>Power consumption</b>	
Typical	3.02 W
Maximum	30.2 W
<b>Insulation Class</b>	A, in accordance with DIN 57110b
Typical output voltage: $V_{CC} - I_{OUT} * R_{ON} - 0.65 \text{ V}$ $V_{CC}$ : Actual P24OUT operating voltage Max. output current $I_{OUT}$ : 1 A Internal resistance $R_{ON}$ : 0.4 $\Omega$ The supply voltage P24OUT is short-circuit proof.	

### External supply voltage P24OUText

If an external supply voltage is used, its reference ground must be connected to X6-2, pin 12 (M).

X6-2, pin 1 (P24OUT) then remains open.

### Electrical specification

Digital inputs	min.	Typical	max.	nominal
Voltage for high-level ( $V_H$ )	15 V	1)	30 V	24 V
Input current $I_{IN}$ at $V_H$	3.7 mA	-	7.5 mA	-
Voltage for low level ( $V_L$ )	-30 V	-	+5 V	0 V
Signal delay $T_{PHL}$ , $T_{PLH}$ 2)	-	3 $\mu$ s	-	-
1) See table "Specification of the supply voltage P24OUT" 2) The PROFIBUS communication time as well as the application cycle time must also be taken into account. Incorrect connection causes neither high level nor destruction of the inputs.				

### Connecting cable

The required connecting cables must be provided by the user.

- Supply voltage X6-2, pin 1 (P24OUT), external supply voltage P24OUText:  
Wire, conductor cross-section of 1.5 mm<sup>2</sup> (AWG16)
- Digital outputs X6-2, pins 2 -11:  
Wire, conductor cross-section 0.5 to 1.5 mm<sup>2</sup> (AWG20 - AWG16)

**General electrical properties**

- Galvanic isolation using optocouplers
- Active current limitation of the inputs
- Protection from negative input voltage

**Probe**

ADI4 supports only measurement of a rising **or** falling edge of the probe. A simultaneous request for measurement of a rising edge and a falling edge of the probe cannot be parameterized.

**4.2.9 Interface (H1/H2): Module status**

The module status is displayed on the front of the module with four diagnostic LEDs.

Table 4- 14 Diagnostic LEDs (H1/H2)

Designation		Color	Description
H1	POWER	Green	Supply voltage LED = Off: Supply voltage not applied LED = On: Supply voltage is applied
	OVTEMP	Red	Overtemperature display LED = Off: Device temperature < overtemperature limit LED = On: Device temperature ≥ Overtemperature limit
H2	EXCHANGE	Green	Status: Message frame exchange with DP master LED = Off: No message frame exchange with DP master LED = On: Cyclic message frame exchange with DP master
	READY	Red	Ready status: Message frame exchange with DP master LED = Off: Not yet ready LED = On: Ready LED = Off and EXCHANGE = On: Message frame exchange active LED = flashing: Error occurred during message frame exchange

**4.3 Control cabinet installation**

**Installation**

For high frequency interference currents, the housing of the ADI4 module must be connected with low-resistance to the back wall of the control cabinet, and this wall in turn must be connected with low-resistance to the motors/machines. The module should be installed on a bare mounting wall. The connection between the mounting wall and the motors/machines must be electrically conductive and have a large surface area. Coated cabinet walls and DIN rails, or similar mounting means with a small contact area, do not meet this requirement.

## Cable routing

Power and signal cables must always be routed separately. All I/O interface (X6-1/X6-2) signal lines should exit jointly. Single strands that are related from the signal point of view must be twisted together. Signal cables and encoder cables should be installed separately.

All cables and lines within the control cabinet should always be placed as close as possible to the control cabinet walls. Extended installation through open space can cause interference injections (antenna effect). The proximity to sources of interference (contactors, transformers, etc.) must be avoided by placing a shield plate between the cable and the source of interference, if necessary. Cables and conductors should not be extended using terminals or similar devices. To protect against interference injections from external sources, signal cables must be shielded.

 <b>WARNING</b>
The module has been designed for operation in an enclosed control cabinet. Operation outside an enclosed control cabinet is not permissible.

## 4.4 Power supply

### ADI4 module

To supply the ADI4 module (+24 VDC), an external power source is needed. The power supply is connected through terminal X1 (P24EXT1) on the front panel of the ADI4 module. Refer to Section "Overview of connections (Page 19)" for more information.

### Digital outputs

To supply (+24 VDC) the digital outputs, an external power source is needed. The power supply is connected through Terminal X6-1, Pin 1 (P24EXT2). Refer to Section "Overview of connections (Page 19)" for more information.

### Digital inputs

If the digital inputs are not supplied with the internal supply voltage of X6-2, Pin 1 (P24OUT), this supply voltage can optionally be replaced with an external power source (+24 VDC, 1 A maximum).

The reference ground (GND) of the external power supply source must be connected with X6-2, Pin 12. X6-2, Pin 1 (P24OUT) remains open.

**Specification of the supply voltages (+24 VDC)**

The external supply voltages for the ADI4 module, the digital outputs, and optionally the digital inputs must comply with the specifications provided in the "Encoder supply voltages" table.

Table 4- 15 Specification of the external supply voltages

	Supply voltage <sup>1)</sup>		
	P24EXT1	P24EXT2	P24OUText
<b>Voltage</b>			
• Minimum		18.5 V	
• Nominal		24 V	
• Maximum		30.2 V	
<b>Ripple</b>			
• Maximum		3.6 V <sub>pp</sub>	
<b>Current load</b>			
• Typical	0.5 A	-	0.1 A
• Maximum	1 A	8 A	1 A
<b>Power consumption</b>			
• Typical	12 W	-	3.02 W
• Maximum	30.2 W	241.6 W	30.2 W
<sup>1)</sup> P24EXT1: Supply voltage of the ADI4 module P24EXT2: Supply voltage for the digital outputs P24OUText: Optional supply voltage for the digital inputs			

<b>CAUTION</b>
The external supply voltages must each be generated as functional extra-low voltage with safe electrical isolation (DIN EN 60204-1, PELV).

**Fuse**

On the module side, supply voltages P24EXT1 and P24EXT2 must be protected against the following:

- Overvoltage
- Short-circuit (electrical current limiting of outputs)
- Polarity reversal
- Overload
  - P24EXT1: Fuse 2.5 A / 250 V
  - P24EXT2: Fuse 8 A / 125 V

## 4.5 Grounding

### Grounding

The module must be installed according to EN 60204.

The user must ground each of the supply voltages. To do this, a connection must be established from Terminal X1, Pin 2 (MEXT1) or X6-1, Pin 15 (MEXT2) to a central grounding point of the system.

If a large-area, permanent metallic connection with the central grounding point is not possible using the rear panel, the module must be connected to the grounding rail by means of a wire (cross-section  $> 10 \text{ mm}^2$ ).

 <b>CAUTION</b>
--

A protective conductor must be connected. An M6 screw is provided on the lower right of the front of the housing to connect the protective conductor. See Chapter "Dimension drawing (Page 38)".
--

### 4.6 Dimension drawing

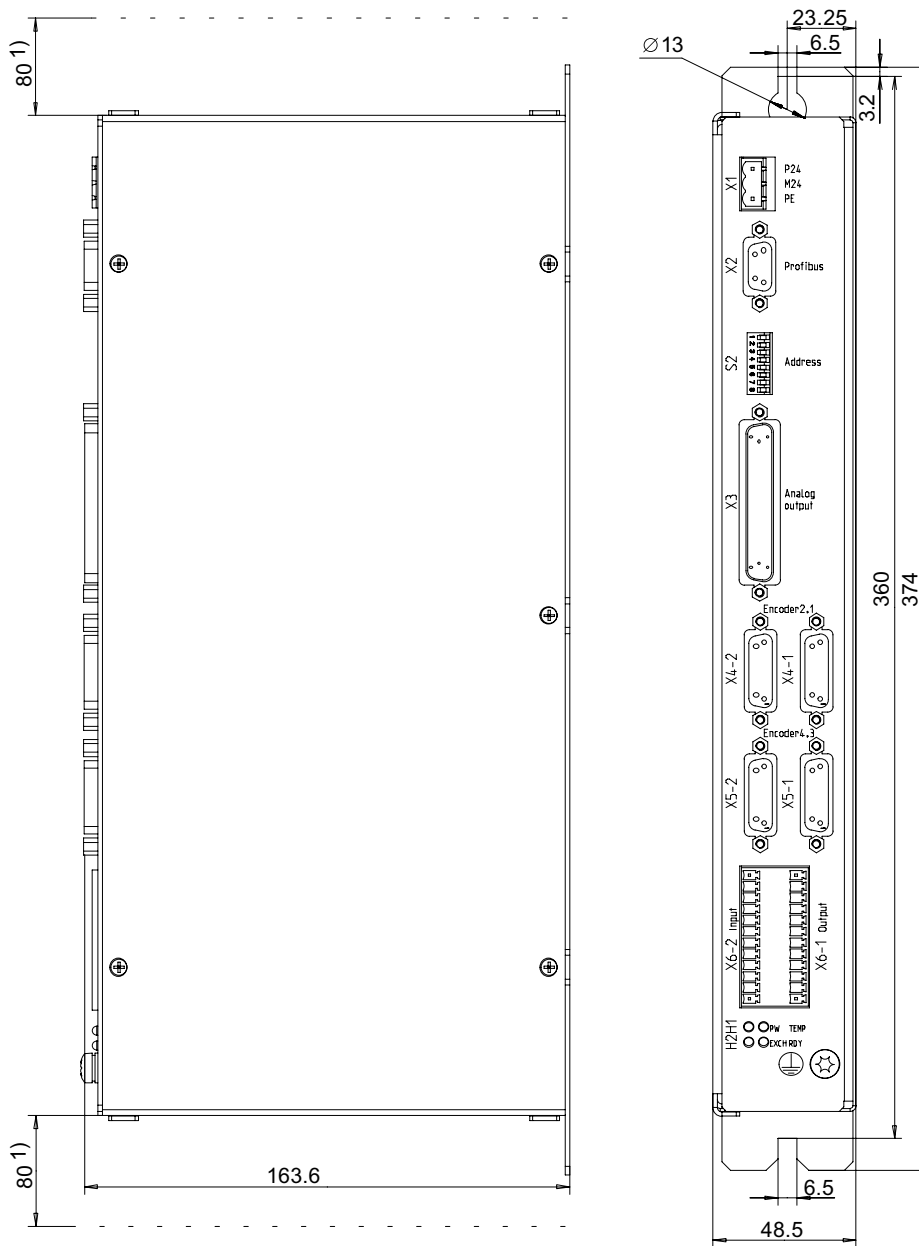

Figure 4-2 Dimension drawing: ADI4

- 1) Necessary clearance to ensure sufficient ventilation
- Maximum tightening torque for all screws: 0.8 Nm

## 4.7 Technical data

Table 4- 16 Technical data of the ADI4 module

<b>Safety</b>		
Degree of protection	IP20	
Protection class	Protection class I in accordance with VDE 0106 Part 1: 1982 (IEC 536); Protection against ingress of foreign bodies and water in accordance with IEC 529	
Approvals	UL/CSA, CE	
<b>Power consumption</b>		
Nominal load	12 W	
Maximum	30.2 W	
<b>Mechanical specifications</b>		
Dimensions WxHxD [mm]	154.4 x 325 x 48.5	
Weight	Approximately 1.5 kg	
<b>Climatic ambient conditions</b>		
Heat dissipation	Open-circuit-ventilated	
	Operation	Storage/transport
Temperature limits	0 ... +55° C	-20 to 55 °C/-40 to 70 °C
Relative humidity limits	5 to 95 % without condensation	5 to 95 % without condensation
Condensation	Not permitted	
Atmospheric pressure	700 to 1060 hPa	700 to 1060 hPa
Transportation altitude	-	-1000 to 3000 m
<b>Shock stress during transportation</b>		
Free fall in transport packaging	≤ 1000 mm	





## Parameter assignment

### 5.1 Boundary conditions of ADI4 DP slave

#### NOTICE

The following boundary conditions must be taken into account for the operation of an ADI4 DP slave on the PROFIBUS DP:

- An ADI4 DP slave is not a certified DP standard slave as defined by the PROFIDrive profile. For example, an ADI4 DP slave does not enable acyclic communication. Therefore, an ADI4 DP slave can only be operated on a DP master specially released for this purpose.
- An ADI4 DP slave can only be operated on an equidistant PROFIBUS DP. The minimum DP cycle is 1 ms.

### 5.2 Preconditions, SINUMERIK 802D sl

The following components are required for assigning parameters for an ADI4 DP slave:

- SINUMERIK 802D sl system software: from version 01.04.xx

### 5.3 Preconditions, SINUMERIK 840Di sl

#### Required components

The following components are required to assign the parameters of SINUMERIK 840Di sl NC and the DP slave ADI4 in SIMATIC STEP7 HW Config:

- References: /HBIsI/ SINUMERIK 840Di sl Manual
- SIMATIC STEP 7, Version 5.3, Service Pack 2 and higher
- SlaveOM (Slave Object Manager) for SINUMERIK 840Di sl

## SlaveOM

The SlaveOM for SINUMERIK 840Di sl allows dialog-based parameter assignment of the DP slave:

- DP slave SINAMICS S120
- ADI4 DP slave

Within the scope of generating the configuration with SIMATIC STEP 7 HW Config.

The SlaveOM for SINUMERIK 840Di sl is part of the SINUMERIK 840Di sl toolbox.

---

### Note

When using the SlaveOM for SINUMERIK 840Di sl in connection with other CPUs, a consistency error is reported during the configuration compilation and no system data blocks are generated.

---

## 5.4 Preconditions, SINUMERIK 840D sl

### Required components

The following components are required to assign the parameters of SINUMERIK 840D sl NC and the DP slave ADI4 in SIMATIC STEP7 HW Config:

- References: Commissioning Manual IBN CNC: NCK, PLC, drive
- SIMATIC STEP7, Version 5.3, Service Pack 3 and higher
- SlaveOM (Slave Object Manager) for SINUMERIK 840D sl

## SlaveOM

The SlaveOM for SINUMERIK 840D sl allows dialog-based parameter assignment of the DP slave:

- DP slave SINAMICS S120
- ADI4 DP slave

Within the scope of generating the configuration with SIMATIC STEP 7 HW Config.

The SlaveOM for SINUMERIK 840D sl is part of the SINUMERIK 840D sl toolbox.

---

### Note

When using the SlaveOM for SINUMERIK 840D sl in connection with other CPUs, a consistency error is reported during the configuration compilation and no system data blocks are generated.

---

## 5.5 PROFIBUS DP parameter assignment

### 5.5.1 Parameter assignment sequence

#### Parameter assignment sequence

The PROFIBUS DP parameter assignment for the ADI4 DP slave can be generally divided into the following steps:

#### 1. Step

After inserting the ADI4 DP slave in the configuration, the following parameters are assigned on a slave-specific basis:

- PROFIBUS parameters (see Chapter "PROFIBUS parameters (Page 45)")
- Function parameters (see Chapter "Function parameters (Page 52)")

Step 1 should be carried out first for **all** ADI4 DP slaves needed in the configuration.

#### 2. Step

Parameter assignment of the DP communication (refer to Chapter "Parameterization of the DP communication (Page 62)")

Step 2 can be performed **last** on **any** ADI4 DP slave. These settings can be transferred to all other ADI4 DP slaves using the alignment function.

## 5.5.2 Inserting an ADI4 DP slave in the configuration

### Procedure

1. To insert an ADI4 DP slave in the configuration, open the hardware catalog using the **View > Catalog** menu command.

The ADI4 DP slave can be found at:

- Profile: **Standard**

**PROFIBUS DP > SINUMERIK > ADI4**

SIMATIC Technology CPU

If S7-Technology was installed for the Technology CPU, the ADI4 DP slave is located under:

- Profile: **SIMATIC Technology CPU**

**PROFIBUS DP (DRIVE) > Other FIELD DEVICES > SINUMERIK > ADI4**

2. Using a drag-and-drop operation, select the ADI4 DP slave and move it onto to the DP master system in the station window.

The DP master system is displayed in the station window with the following symbol:



When you release the left mouse button, the DP slave ADI4 is inserted into the configuration.

---

### Note

As you drag the DP slave, the cursor appears as a circle with a slash through it. When the cursor is positioned exactly over the DP master system, it changes to a plus sign, and the DP slave can be added to the configuration.

---

## 5.6 PROFIBUS parameters for SINUMERIK 802D sl

The PROFIBUS parameters are set for SINUMERIK 802D sl by activating one of the defined configurations supplied. The PROFIBUS parameter values of the various configurations as well as the activation of a configuration are described in:

### References

SINUMERIK 802D sl Toolbox > Readme: ADI4\_SDB.PDF

## 5.7 PROFIBUS parameters

### 5.7.1 Parameter components

#### Configuring the PROFIBUS parameters

The PROFIBUS parameters are a result of the following:

- PROFIBUS address
- Number of axes and encoders (message frame type)
- I/O addresses

### 5.7.2 PROFIBUS address

#### Procedure

Inserting an ADI4 DP slave into the configuration will open the "Properties - PROFIBUS Interface ADI4" dialog, "Parameters" tab:

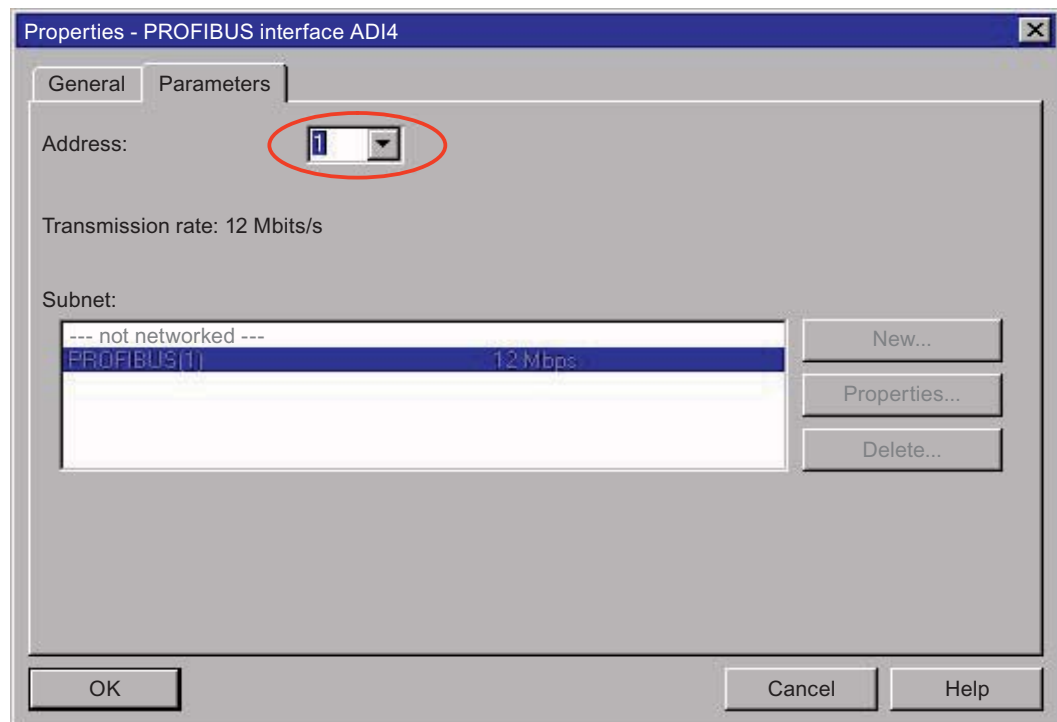

Figure 5-1 PROFIBUS address

The displayed address value was automatically set by HW Config to the next available PROFIBUS address within the configuration.

<b>NOTICE</b>
The PROFIBUS address of the ADI4 DP slave can be set to any value, in principle. However, it must be ensured that the PROFIBUS address setting in HW Config matches the DIP switch setting on the ADI4 DP slave:  There is <b>no automatic adjustment!</b>  The following data must agree: <ul style="list-style-type: none"><li>• SIMATIC S7 configuration ADI4 DP slave <b>PROFIBUS address</b></li><li>• ADI4 module DIP switch S2 <b>PROFIBUS address</b></li></ul>

---

**Note**

**PROFIBUS address 127**

If PROFIBUS address is set to 127, when the module powers up, the firmware release is displayed on the internal module LEDs using a flashing code. It is not recommended to use PROFIBUS address 127 as this lengthens the time that the module requires to power up.

---

After the dialog is confirmed with "OK", the "DP Slave Properties" dialog box is opened. Continue with the parameter assignment for the message frame type.

### 5.7.3 Message frame type

#### Message frame type

The ADI4 DP slave is operated with a specific message frame type:

4 axes, each with one encoder (standard message frame 3) and I/O data

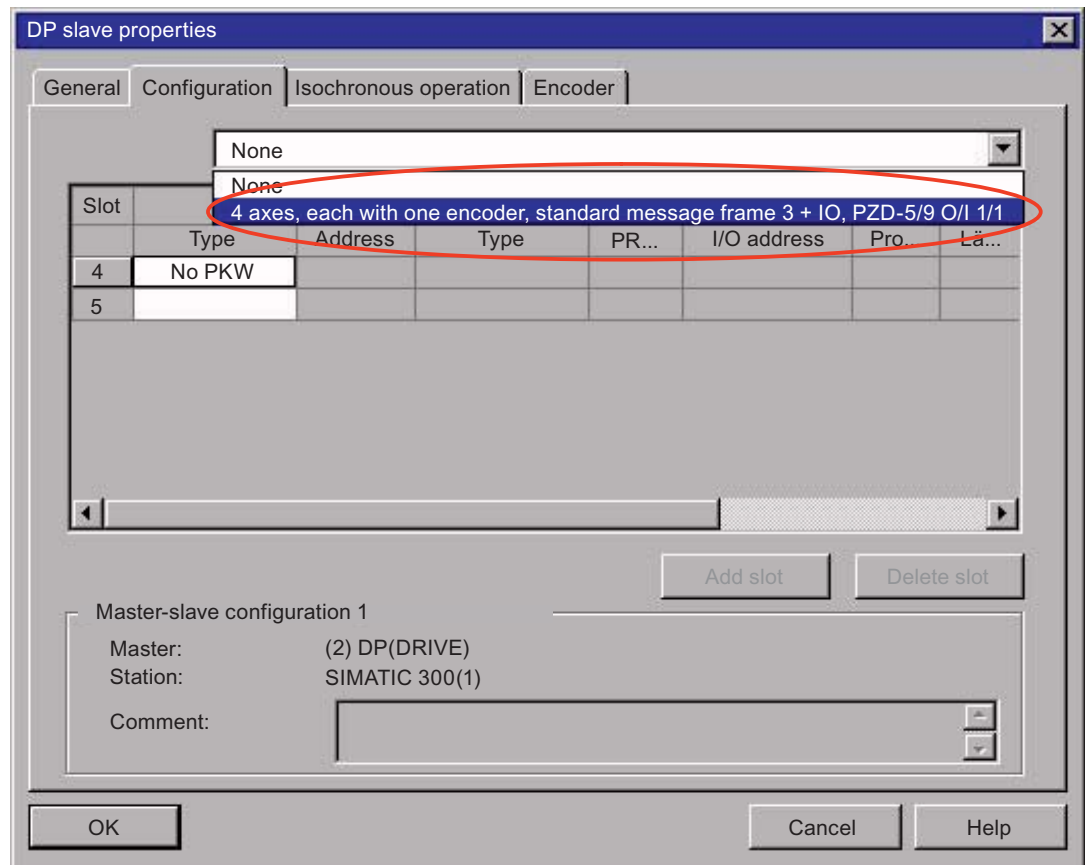

Figure 5-2 Message frame type

### Setting the message frame type

By default, no message frame type is selected. The ADI4-specific message frame type must be explicitly selected in the "Configuration" tab.

1. In the "DP Slave Properties" dialog box, select the "Configuration" tab.
2. In the "Default" list, select the entry "4 axes, each with one encoder, Standard message frame 3 + IO, PZD-5/9 O/I 1/1".
3. Click "OK".

**Message frame structure**

The message frame is structured as follows:

Table 5- 1 Message frame structure

Message frame type	Description																																				
4 axes, each with one encoder, Standard message frame 3 + IO, PZD-5/9 O/I 1/1	4 x Standard message frame 3 and 1 PZD word each for digital I/O data																																				
PZD x/y Number of process data words, x: Setpoint, y: Actual value, e.g. PZD-5/9: 5 process data words for setpoints 9 process data words for actual values																																					
ADI4 message frame structure <table style="width: 100%; border-collapse: collapse;"> <tr> <td style="text-align: center;">Axis1</td> <td style="text-align: center;">Axis2</td> <td style="text-align: center;">Axis3</td> <td style="text-align: center;">Axis4</td> <td style="text-align: center;">I/O</td> <td></td> </tr> <tr> <td style="text-align: center;">STD 3</td> <td style="text-align: center;">STD 3</td> <td style="text-align: center;">STD 3</td> <td style="text-align: center;">STD 3</td> <td style="text-align: center;">O word</td> <td style="text-align: right;">Setpoints (master -&gt; slave)</td> </tr> </table> Low <table style="width: 100%; border-collapse: collapse;"> <tr> <td style="text-align: center;">Axis1</td> <td style="text-align: center;">Axis2</td> <td style="text-align: center;">Axis3</td> <td style="text-align: center;">Axis4</td> <td style="text-align: center;">I/O</td> <td style="text-align: right;">High</td> </tr> <tr> <td style="text-align: center;">STD 3</td> <td style="text-align: center;">STD 3</td> <td style="text-align: center;">STD 3</td> <td style="text-align: center;">STD 3</td> <td style="text-align: center;">O word</td> <td style="text-align: right;">Actual values (slave -&gt; master)</td> </tr> </table> STD 3: standard message frame 3 per PROFIDrive Specification V3.0 Q word: digital output data (16 bits) I word: digital input data (16 bits)		Axis1	Axis2	Axis3	Axis4	I/O		STD 3	STD 3	STD 3	STD 3	O word	Setpoints (master -> slave)	Axis1	Axis2	Axis3	Axis4	I/O	High	STD 3	STD 3	STD 3	STD 3	O word	Actual values (slave -> master)												
Axis1	Axis2	Axis3	Axis4	I/O																																	
STD 3	STD 3	STD 3	STD 3	O word	Setpoints (master -> slave)																																
Axis1	Axis2	Axis3	Axis4	I/O	High																																
STD 3	STD 3	STD 3	STD 3	O word	Actual values (slave -> master)																																
Standard message frame 3: speed setpoint interface 32 bits with 1 encoder <table style="width: 100%; border-collapse: collapse;"> <tr> <td style="text-align: center;">PZD1</td> <td style="text-align: center;">PZD2</td> <td style="text-align: center;">PZD3</td> <td style="text-align: center;">PZD4</td> <td style="text-align: center;">PZD5</td> <td></td> </tr> <tr> <td style="text-align: center;">STW1</td> <td colspan="2" style="text-align: center;">NSET_B</td> <td style="text-align: center;">STW2</td> <td style="text-align: center;">G1_STW</td> <td style="text-align: right;">Setpoint (master -&gt; slave)</td> </tr> </table> Low <table style="width: 100%; border-collapse: collapse;"> <tr> <td style="text-align: center;">PZD1</td> <td style="text-align: center;">PZD2</td> <td style="text-align: center;">PZD3</td> <td style="text-align: center;">PZD4</td> <td style="text-align: center;">PZD5</td> <td style="text-align: right;">High</td> </tr> <tr> <td style="text-align: center;">ZSW1</td> <td colspan="2" style="text-align: center;">NACT_B</td> <td style="text-align: center;">ZSW2</td> <td style="text-align: center;">G1_ZSW</td> <td style="text-align: right;">PZD6 PZD7</td> </tr> <tr> <td colspan="3"></td> <td style="text-align: center;">PZD8</td> <td style="text-align: center;">PZD9</td> <td></td> </tr> <tr> <td colspan="4"></td> <td style="text-align: center;">G1_XIST2</td> <td style="text-align: right;">Actual value (slave -&gt; master)</td> </tr> </table>		PZD1	PZD2	PZD3	PZD4	PZD5		STW1	NSET_B		STW2	G1_STW	Setpoint (master -> slave)	PZD1	PZD2	PZD3	PZD4	PZD5	High	ZSW1	NACT_B		ZSW2	G1_ZSW	PZD6 PZD7				PZD8	PZD9						G1_XIST2	Actual value (slave -> master)
PZD1	PZD2	PZD3	PZD4	PZD5																																	
STW1	NSET_B		STW2	G1_STW	Setpoint (master -> slave)																																
PZD1	PZD2	PZD3	PZD4	PZD5	High																																
ZSW1	NACT_B		ZSW2	G1_ZSW	PZD6 PZD7																																
			PZD8	PZD9																																	
				G1_XIST2	Actual value (slave -> master)																																



Message frame type	Description																		
<p>O word (dig. output data 16 bits)</p> <table border="1" style="margin-left: 20px;"> <tr> <th colspan="4">High-Byte</th> <th colspan="4">Low-Byte</th> </tr> <tr> <td>15</td> <td>12</td> <td>11</td> <td>8</td> <td>7</td> <td>4</td> <td>3</td> <td>0</td> </tr> </table>	High-Byte				Low-Byte				15	12	11	8	7	4	3	0	<p>Dig. outputs 1-4 -&gt; X6-1: Pin 2-5</p> <p>Dig. output 5-8 / direction signal 1-4 for unipolar spindle -&gt; X6-1: Pin 6-9</p> <p>611U conformant mode Select: Homing using external zero mark signals 1 to 4</p> <p>Not used</p>		
High-Byte				Low-Byte															
15	12	11	8	7	4	3	0												
<p>O word (dig. output data 16 bits)</p> <table border="1" style="margin-left: 20px;"> <tr> <th colspan="4">High-Byte</th> <th colspan="4">Low-Byte</th> </tr> <tr> <td>15</td> <td>10</td> <td>9</td> <td>8</td> <td>7</td> <td>6</td> <td>5</td> <td>4</td> <td>3</td> <td>0</td> </tr> </table>	High-Byte				Low-Byte				15	10	9	8	7	6	5	4	3	0	<p>Dig. inputs 1-4/ext. zero marks 1-4 -&gt; X6-2: Pin 2-5</p> <p>Dig. input 5-6 / Measuring input 1-2 -&gt; X6-2: Pin 6-7</p> <p>Dig. input 7-8 / Drv_Rdy 1-2 -&gt; X6-2: Pin 8-9</p> <p>Dig. input 9-10/Drv_Rdy 3-4 -&gt; X6-2: Pin 10-11</p> <p>Not used</p>
High-Byte				Low-Byte															
15	10	9	8	7	6	5	4	3	0										

### NOTICE

The message frame type setting for the ADI4 DP slave in HW Config must agree with the message frame type setting in the controller.

There is **no automatic adjustment**.

### Encoder control word Gx\_STW

Description of the encoder control word (extract) for:

- Find reference mark
- On-the-fly measurement
- Encoder error

Table 5- 2 Encoder control word Gx\_STW (extract)

Bit	Name	Signal status, description									
<b>Find reference mark: Bit 7 = 0</b>											
		<table border="1"> <thead> <tr> <th>Bit</th> <th>Meaning</th> <th>Homing using:</th> </tr> </thead> <tbody> <tr> <td>0</td> <td>Function 1:</td> <td>Encoder zero mark (except in "611U conformant mode")</td> </tr> <tr> <td>1</td> <td>Function 2:</td> <td>Rising edge of external zero mark</td> </tr> </tbody> </table>	Bit	Meaning	Homing using:	0	Function 1:	Encoder zero mark (except in "611U conformant mode")	1	Function 2:	Rising edge of external zero mark
Bit	Meaning	Homing using:									
0	Function 1:	Encoder zero mark (except in "611U conformant mode")									
1	Function 2:	Rising edge of external zero mark									

Bit	Name	Signal status, description					
0	Find reference mark or On-the-fly measurement	Functions	2	Function 3:	Falling edge of external zero mark		
			3	Function 4:	Not used		
<b>On-the-fly measurement: Bit 7 = 1</b>							
1			<b>Bit</b>	<b>Meaning</b>	Measuring using:		
					0	Function 1:	Measuring Input 1 rising edge
					1	Function 2:	Measuring Input 1 falling edge
					2	Function 3:	Measuring Input 2 rising edge
2			3	Function 4:	Measuring Input 2 falling edge		
					<b>Note</b>		
3			<ul style="list-style-type: none"> <li>Bit 0 to 3 Bit x = 1 Function requested Bit x = 0 Function not requested</li> <li>If more than one function is enabled, the values for all functions cannot be read until all functions have ended and this has been signaled via the relevant status bit (G1_ZSW, Bit 0 - Bit 3 = 0).</li> <li>On-the-fly measurement The rising and falling edges of the measuring input can be enabled simultaneously. The measuring input signal is detected according to the direction of the signal change. The measured values are read out consecutively. Notice ADI4 only supports measurement on a rising or falling edge.</li> <li>Find reference mark and on-the-fly measurement Only one of the two functions can be active at a time.</li> </ul>				
			4	<b>Command</b>	<b>Bit 6, 5, 4</b>		<b>Meaning</b>
000					--		
001					Activate function x		
010					Read value x		
5			011		Cancel function x		
6	<b>Mode</b>	0		Find reference mark			
		1		On-the-fly measurement			
7							
:	:						
15	Encoder error	0		No error			
		1		Encoder error pending; error code in Gx_XIST2			

**Additional encoder actual value Gx\_XIST2**

Error codes in Gx\_XIST2 where G1\_ZSW, Bit 15 = 1

Table 5- 3 Error codes in Gx\_XIST2

G1_XIST2	Meaning	Possible causes/description
1 <sub>Hex</sub>	Encoder sum error	The encoder signal levels are too low, faulty (inadequate shielding) or cable breakage monitoring has been tripped.
2 <sub>Hex</sub>	Zero mark monitoring	A fluctuation in the measured rotor position has arisen between two encoder zero marks (encoder pulses may be lost).

## 5.7.4 I/O addresses

### Requirements

For communication between the controller and the individual axes of an ADI4 DP slave, it is necessary that the setpoint and the actual value of an axis have the same I/O address.

HW Config takes this requirement into account automatically when an ADI4 DP slave is inserted in the configuration.

### Inserting I/O addresses

1. In the "DP Slave Properties" dialog box, select the "Configuration" tab.
2. Under PROFIBUS partner, I/O addr., enter: **<I/O address>**.
3. Click "OK".

#### NOTICE

The setpoint and actual value of an axis must have the same I/O address.

**I address (actual value) = O address (setpoint)**

If an ADI4 DP slave is inserted into an S7 project through a copy operation, e.g., from another S7 project, the I/O addresses are assigned directly by HW Config. This may have the consequence that an axis is assigned different I/O addresses for setpoint and actual values. The I/O addresses must be manually corrected in this case.

To avoid access conflicts between the PROFIBUS DP drives and the I/O modules, values  $\geq 272$  must be used for I/O addresses for the ADI4 DP slave.

## 5.7.5 Consistency

### Consistency setting

The default setting for I/O data consistency is "Total length".

The "Total length" consistency setting means that direct access from the PLC user program (e.g. byte, word, or double word) to this address area of the PLC operating system is not permitted.

## 5.8 Function parameters for SINUMERIK 802D sl

### Parameter values

The function parameters are permanently specified in the preset configuration and cannot be changed.

The following parameter values are set:

- Sensor type: TTL <sup>1)</sup>
- Unipolar spindle: "Inactive"
- Shutdown ramp: 0
- Shutdown delay time: 0
- Tolerable sign-of-life failures: 0
- Reserved bits for fine resolution: 11
- 611U conformant mode: "Active"

<sup>1)</sup> Incremental encoder (TTL) with differential transmission of 5 V square wave signals (RS 422 Standard).

## 5.9 Function parameters

### Parameters

The function-specific parameters of the ADI4 DP slave are entered under the "Encoder" tab:

- Encoder type
- Unipolar spindle (or unipolar motor)
- Shutdown ramp
- Shutdown delay
- Tolerable sign-of-life failures
- Reserved bits for fine resolution
- 611U conformant mode

The figure below shows the corresponding dialog box with sample values for the various encoder types and parameters.

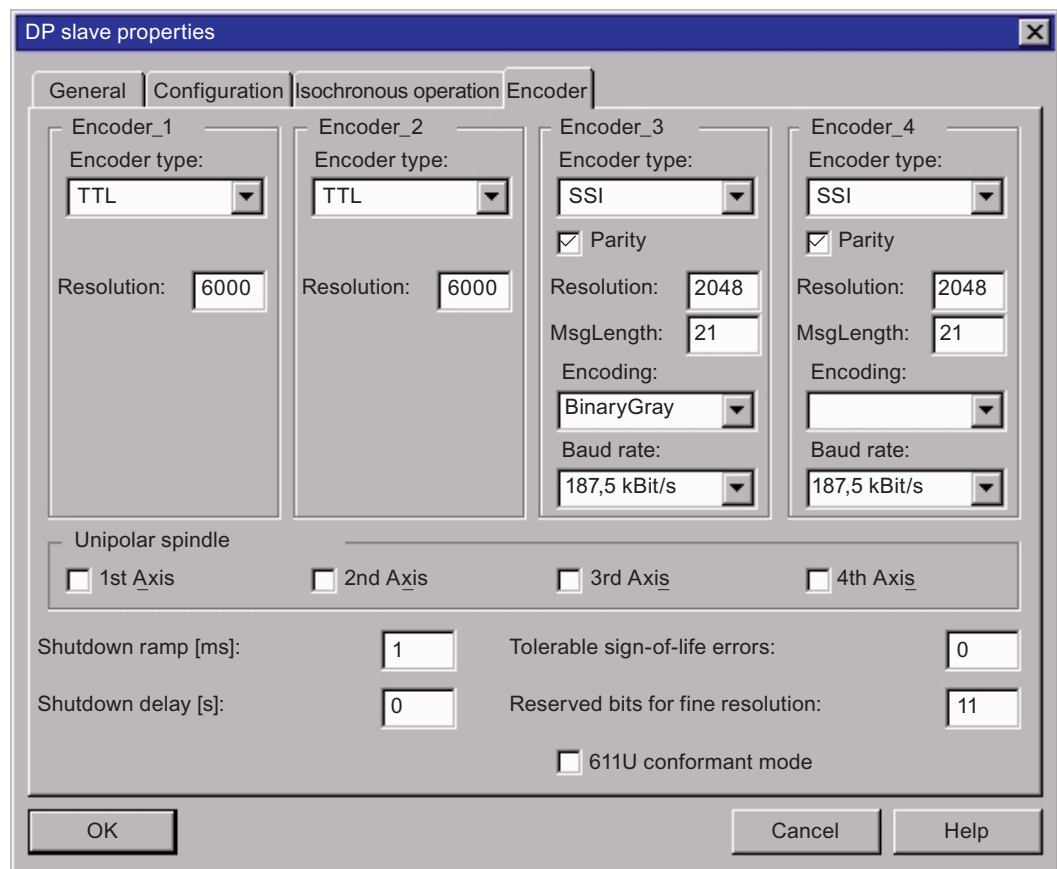

Figure 5-3 "DP Slave Properties" dialog box, "Encoder" tab

## 5.9.1 Encoder type

### Encoder type "not available"

An encoder type setting of "not available" for encoder x means that axis x does not exist, or that it is not to be operated. Net data transmitted for this axis in the PROFIBUS message frame are empty.

### Encoder type TTL

Encoder parameter:

- Resolution  
Encoder resolution in encoder pulses per encoder revolution

---

**Note**

In the case of spindles with a low-resolution encoder, the actual-value characteristic (incrementing) may be displayed in a non-linear fashion. The grid that is visible on the actual-value display is the result of the speed resolution (RR), where:

$$RR = 60000 / ( Tdp * ER * PM )$$

- RR (speed resolution): [(revolutions/min) / encoder pulse]
- Tdp (position control cycle clock = PROFIBUS cycle clock): [ms]
- ER (encoder resolution): [Encoder pulse / revolution]
- PM (pulse multiplication)

Example:

Tdp (position control cycle clock = PROFIBUS cycle clock): 2 ms

ER (encoder resolution): 2500 pulses/revolution

PM (pulse multiplication): 4

$$RR = 60000 / ( 2 * 2500 * 4 ) = 3 \text{ (revolutions/min) / encoder pulse}$$

---

**(SINUMERIK 840Di sl, SINUMERIK 840D sl)**

Smoothing of the actual value for low-resolution encoders via machine data:  
MD34990 \$MA\_ENC\_ACTVAL\_SMOOTH\_TIME (smoothing time constant)

**Encoder type SSI**

Encoder parameters:

- Parity  
Select this check box if the encoder data are to be transmitted from the encoder to the ADI4 with a parity bit.
- Resolution  
Encoder resolution in encoder pulses per encoder revolution
- MsgLength  
Number of net data bits transmitted from the encoder

- Encoding  
The following encoder codes are supported:
  - Binary
  - Gray
- Baud rate  
The following baud rates are supported:
  - 187.5 kbit/s
  - 375 kbit/s
  - 750 kbit/s

#### NOTICE

Regarding SSI encoders (absolute encoders), the following limitations should be observed:

- The baud rate setting must be identical for all SSI encoders. If baud rate settings are different, the baud rate of the SSI encoder with the highest encoder number is used.
- In conjunction with ADI4, only SSI encoders with "Christmas tree" data output format (TSSI) can be operated.

## 5.9.2 Unipolar spindle or unipolar motor

### Introduction

The drive can be moved in two directions. Selecting the "Unipolar spindle" option switches over the voltage range of the analog output voltage.

### Unipolar spindle not selected

If the "Unipolar spindle" option button is **not** selected, an analog voltage in the range of **-10 V** to **+10 V** is output as the setpoint.

### Unipolar spindle selected

If the "Unipolar spindle" option button is **selected**, an analog voltage in the range of **0 V** to **+10 V** is output as the setpoint. Depending on the actual speed setpoint, the direction of rotation is then output via a digital output of the ADI4:

- Direction of rotation signal for axis 1 -> digital output X6-1, pin 6
- Direction of rotation signal for axis 2 -> digital output X6-1, pin 7
- Direction of rotation signal for axis 3 -> digital output X6-1, pin 8
- Direction of rotation signal for axis 4 -> digital output X6-1, pin 9

### Direction of rotation signal

The following voltage level is available at the digital outputs X6-1, pins 6 - 9 depending on the direction of rotation:

- M3 (spindle CW)= 24 V
- M4 (spindle CCW) = 0 V
- M5 (spindle stop) = 24 V

### 5.9.3 Shutdown ramp

#### Shutdown ramp

The "Shutdown ramp" parameter specifies a function that is linear with respect to time. If an error is detected in the ADI4, all ADI4 drives are slowed down to Setpoint "0" in accordance with this function.

A parameter value of "0" brings the drives to an immediate stop (braking at the current limit).

- Unit: [ms]

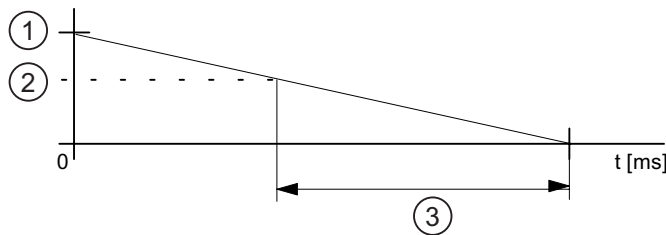

Figure 5-4 Parameter: Shutdown ramp

- ① Maximum setpoint
- ② Current setpoint
- ③ Parameter value: Shutdown ramp

### 5.9.4 Shutdown delay

#### Shutdown delay parameter

The "Shutdown delay" parameter can be used to specify a time after which all ADI4 drives are slowed down to the setpoint "0" following a temperature alarm in the ADI4.

After the "Shutdown delay" has elapsed, the "Shutdown ramp" is taken into account.

- Unit: [s]



## 5.9.5 Tolerable sign-of-life failures

### "Tolerable sign-of-life failures" parameter

The "Tolerable sign-of-life failures" parameter specifies the number of sign-of-life failures tolerated for the DP master. If the assigned number is exceeded, the setpoint interfaces of the drives are ramped down to the value "0" using the "Shutdown ramp".

<b>NOTICE</b>
Presently, the "Tolerable sign-of-life failures" parameter may only be used on values in the range of 0 to 13.

## 5.9.6 Reserved bits for fine resolution

### "Additional substitute bits for fine resolution" parameter

The "Additional substitute bits for fine resolution" parameter specifies the desired pulse multiplication of the encoder increments transmitted in actual encoder values G1\_XIST1 and G1\_XIST2.

Presently, the number of additional substitute bits for fine resolution must be set permanently to 11. This corresponds to a pulse multiplication of:  $2^{11} = 2048$ .

<b>NOTICE</b>
The "Reserved bits for fine resolution" parameter must always be set to 11.

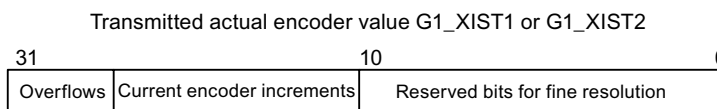

(SINUMERIK 840Di sI, SINUMERIK 840D sI)

<b>NOTICE</b>
Corresponding to the "Additional substitute bits for fine resolution" parameter, the following must be entered in the axis-specific machine data: MD30260 \$MA_ABS_INC_RATIO (ratio of the absolute resolution to the incremental resolution) the value $2^{\text{"Additional fine bits for fine resolution"}} = 2^{11} = 2048$ .

### 5.9.7 611U conformant mode

#### Setting options

In 611U conformant mode, the signal source for homing of axes is no longer specified using the PROFIDrive standard message frame (STD3, encoder control word G1\_STW), but rather using the additional digital output word in the PROFIBUS message frame of the ADI4 (see table "Message frame structure" in the "Message frame type" section).

611U conformant mode:

- Not selected  
 The signal source for homing is specified via the encoder control word Gx\_STW in the PROFIDrive standard message frame.
- Selected  
 The signal source for homing is specified via the additional digital output word in the PROFIBUS message frame.

#### Digital output word

The signal sources for the homing are selected on an axis-specific basis via the following bits of the output word (see also output word in the table "Message frame structure" in the "Message frame type" section)

Table 5- 4 Output word: Signal sources for homing

Bit	Value	Signal source for homing
8	0	Axis 1: Zero mark of encoder 1 (X4-1)
	1	Axis 1: <b>Rising</b> edge of external zero mark 1 (X6-2, pin 2)
9	0	Axis 2: Zero mark of encoder 2 (X4-2)
	1	Axis 2: <b>Rising</b> edge of external zero mark 2 (X6-2, pin 3)
10	0	Axis 3: Zero mark of encoder 3 (X4-3)
	1	Axis 3: <b>Rising</b> edge of external zero mark 3 (X6-2, pin 4)
11	0	Axis 4: Zero mark of encoder 4 (X4-4)
	1	Axis 4: <b>Rising</b> edge of external zero mark 4 (X6-2, pin 5)

If the 611U conformant mode has been parameterized for an axis to be homed, the axis-specific signal for selection of the signal source must be set in the digital output word of the ADI4 from the PLC user program, before the "Reference mark search" function is requested in the encoder control word.

The following sections show the basic system structure and the respective boundary conditions of the individual homing methods.

#### Exiting the dialog box

If the "DP Slave Properties" dialog box is exited with "OK", the data are accepted and the dialog box is closed.

### Step1: End

Step 1 of the ADI4 DP slave parameterization is now complete.

### See also

Message frame type (Page 46)

Boundary conditions (Page 61)

## 5.9.8 Homing using encoder zero mark

### System setup

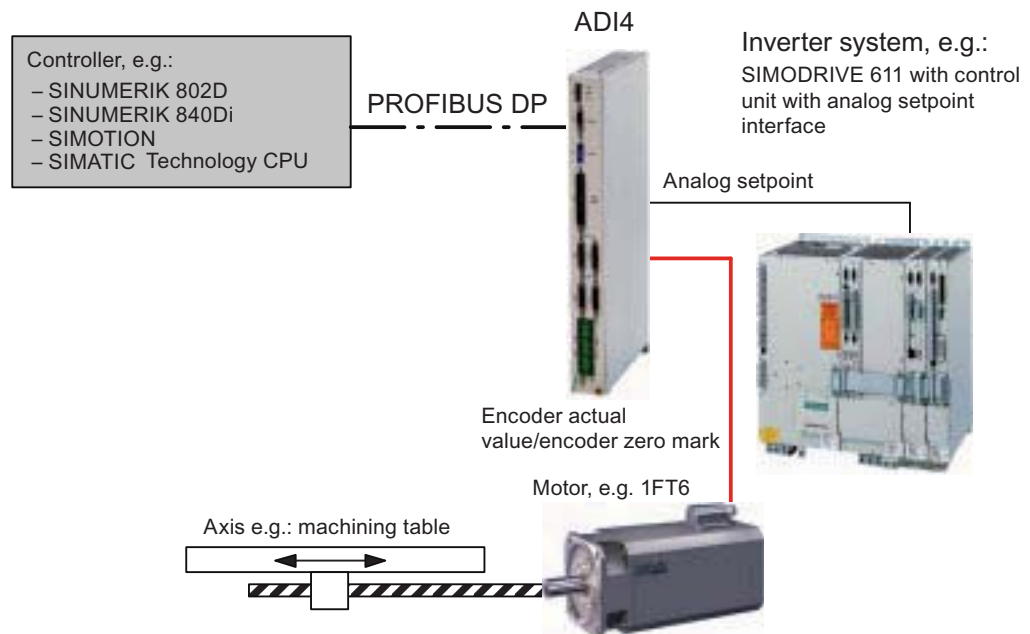

Figure 5-5 Basic system structure: Homing using encoder zero mark

### Function

Once the controller requests homing, the ADI4 transmits the actual encoder value to the controller as the home position the next time it detects an encoder zero mark.

### Without 611U conformant mode

No further measures are required.

### With 611U conformant mode

The relevant signal for the axis to be homed (e.g. axis 1) must be set in the digital output word:

- Digital output word:  
Bit 8: = 0 => "Axis 1: Zero mark of encoder 1 (X4-1)"

## 5.9.9 Homing using external zero mark

### System setup

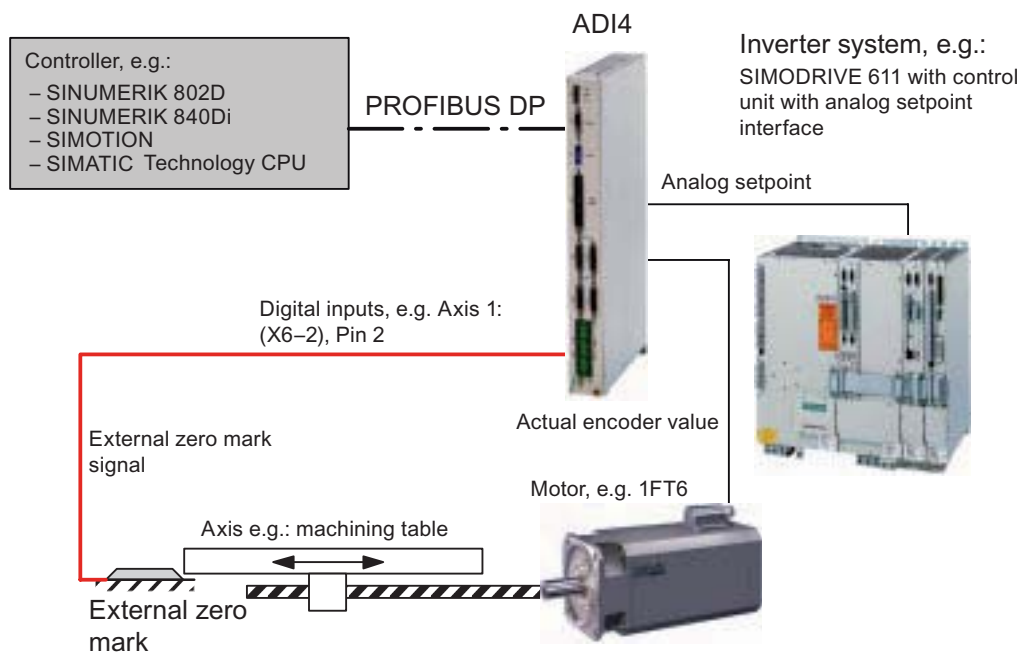

Figure 5-6 Basic system structure: Homing using external zero mark

### Function

Once the controller requests homing, the ADI4 transmits the actual encoder value to the controller as the home position the next time it detects an external zero mark signal.

### Without 611U conformant mode

The controller must define the relevant function via encoder control word G1\_STW:

- Function 2 (homing via rising edge of external zero mark)
- Function 3 (homing via falling edge of external zero mark)

### **With 611U conformant mode**

The relevant signal for the axis to be homed (e.g. axis 1) must be set in the digital output word:

- Digital output word:  
Bit 8: = 1 => "Axis 1: Rising edge of external zero mark 1 (X6-2, pin 2)"

---

#### **Note**

Homing using an external zero mark requires 611U conformant mode to be selected.

---

## **5.9.10 Boundary conditions**

### **Probe or on-the-fly measurement**

ADI4 supports only measurement using a rising **or** falling edge of the probe. It is not possible to parameterize simultaneous measurement on a rising edge and a negative edge.

### **Speed actual value**

The actual speed value (PZD2/3: NACT\_B) contained in standard message frame 3 (see table "Message frame structure" in the "Message frame type" section) is not supported by the ADI4. The ADI4 always sends a value of 0 as the actual speed value.

### **External encoder interface (encoders without an axis)**

If only encoders are connected to the ADI4 without at least one axis being parameterized, i.e. the ADI4 uses the encoder as an external encoder interface only, a "Ready" signal (interface X6-1, pin 10/11) is not output. For information on the "Ready" signal, refer to section "Interface (X6-1): Digital outputs".

### **See also**

Interface (X6-1): Digital outputs (Page 28)

## 5.10 Parameterization of the DP communication

### 5.10.1 Parameter assignment of the equidistant cyclic DP communication

#### Action steps

Once all the DP slaves have been inserted in the configuration and their function parameters have been assigned as described (Step 1), the parameters for the equidistant cyclic DP communication must then be assigned (Step 2).

Parameters are assigned to the equidistant cyclic DP communication in two steps, as well:

#### Step 1

- Activation of the equidistant DP cycle
- Equidistant master cyclic component  $T_{DX}$

#### Step 2

- Equidistant DP cycle  $T_{DP}$
- Master application cycle  $T_{MAPC}$
- Actual value acquisition  $T_i$
- Setpoint acceptance  $T_o$

<b>NOTICE</b>
When assigning parameters for DP communication, you must observe the boundary conditions applicable to the individual parameters.

#### See also

Boundary conditions (Page 78)

## 5.10.2 Activation of the equidistant DP cycle

### Procedure

Double-click an ADI4 DP slave. In the station window of HW Config, the dialog box: "DP Slave Properties" opens.

---

#### Note

It is recommended that the equidistant DP cycle be enabled for all ADI4 DP slaves by enabling the equidistant DP cycle within the selected ADI4 DP slave, and then performing an alignment:

During an alignment, all values displayed in the "DP Slave Properties" dialog box, "Isochronous mode" tab are transferred to all DP slaves of the same type, ADI4 DP slave here, of the configuration.

---

### Dialog: Start

Dialog: DP slave properties

Tab: Isochronous operation

Radio button: Synchronize drive to equidistant DP cycle

Button: Alignment

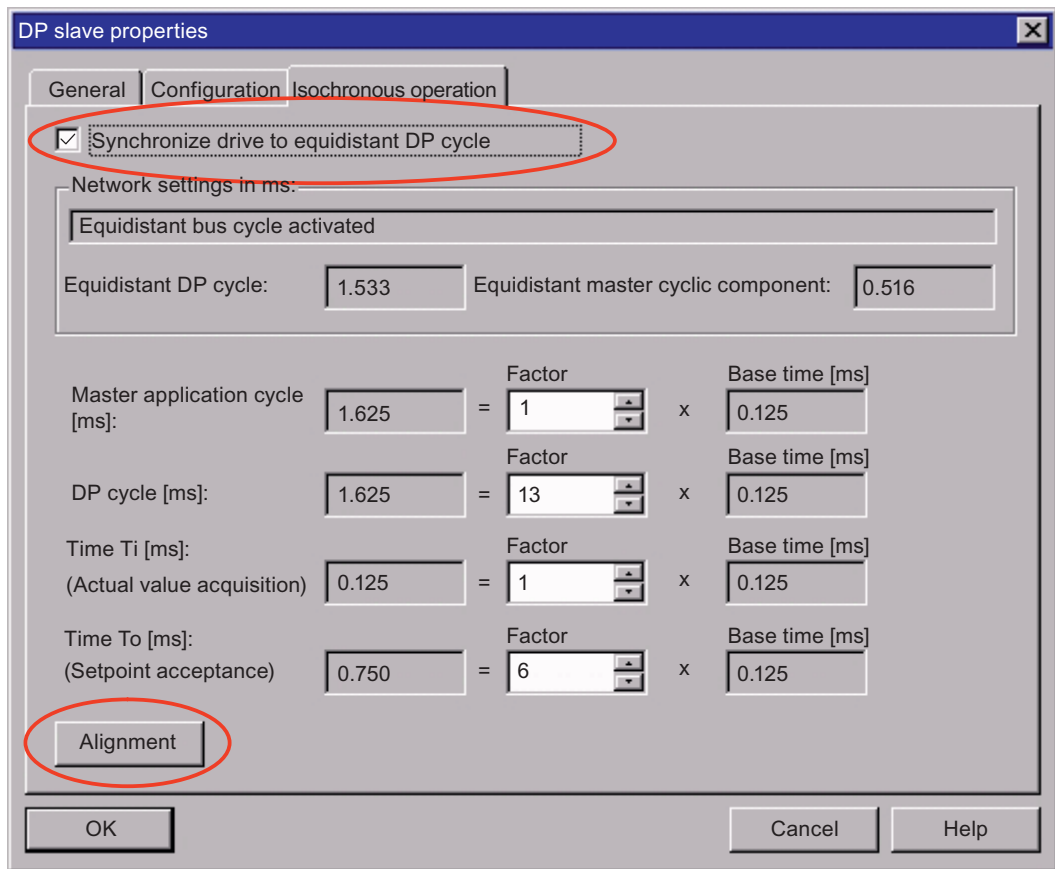

Figure 5-7 "DP Slave Properties" dialog box

### 5.10.3 Equidistant master cyclic component TDX

#### Procedure

Once synchronization to the equidistant DP cycle has been enabled for all DP slaves, the time required for the cyclic component of the DP communication must be recalculated.

The calculation is performed automatically by the DP master each time the equidistant bus cycle is enabled. This is performed in the following dialog box by selecting/clearing the "Activate equidistant bus cycle" check box.

#### Dialog: Continuation

Dialog box: DP slave properties

Tab: General

Group: Node/Master System

Button: PROFIBUS...



Dialog box: Properties - PROFIBUS interface ADI4 ...

Tab: Parameters

Button: Properties...

Dialog box: PROFIBUS properties

Tab: Network settings

Button: Options...

Dialog box: Options

Tab: Equidistance

1. Radio button: Activate equidistant bus cycle  (deselect)
2. Radio button: Activate equidistant bus cycle  (select)

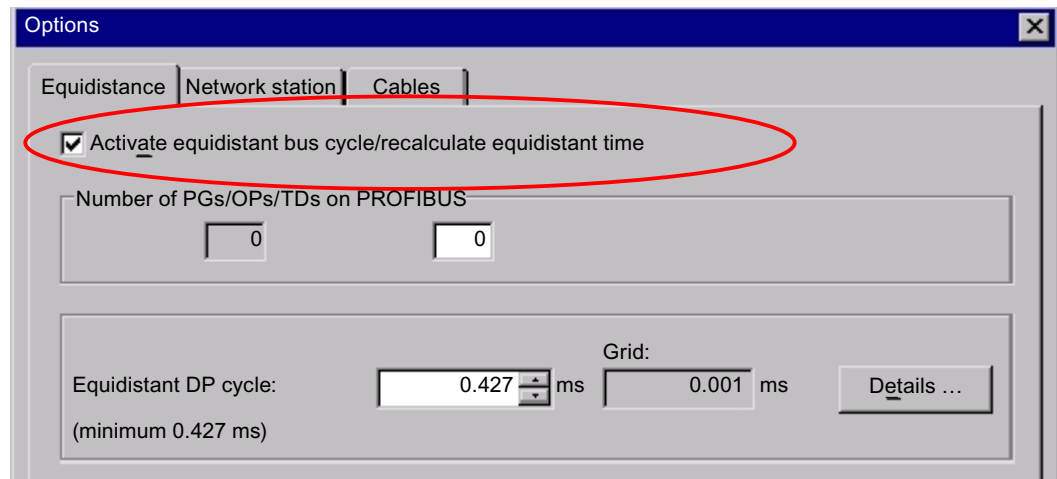

Figure 5-8 "Options" dialog box (excerpt)

### Note

If there are different equidistant DP slave types (for example, different SIMODRIVE drives, ADI4, etc.) in an S7 project, you must first perform the following two steps for each DP slave type:

1. Synchronize drive to equidistant DP cycle
2. Perform alignment

You can then continue to set the other parameters.

### 5.10.4 Equidistant DP cycle TDP

#### Procedure

When the cyclic component of the DP communication is calculated, the DP master automatically changes the value for the equidistant DP cycle to the minimum required time. This change must be undone by re-entering the intended value for the equidistant DP cycle.

#### (SINUMERIK 840D sl)

##### Equidistant DP cycle

For SINUMERIK 840D sl, an ADI4 module is connected via an external PROFIBUS (connection: DP1, X126 or DP2/MPI, X136). The DP cycle - with constant bus cycle time - of the external PROFIBUS must then be set the same as the position controller clock cycle parameterized in the NC or the equidistant DP cycle of the internal PROFIBUS.

---

##### Note

The DP cycle of the external PROFIBUS must be the same as that of the internal PROFIBUS:

Equidistant DP cycle (external PROFIBUS) = position controller cycle = equidistant DP cycle (internal PROFIBUS)

---

##### Connection to "NCU7x0.2 PN"

If an ADI4 module is connected to NCU module "NCU7x0.2 PN" then a module with the following version and higher must be used: MLFB ...-0AA2

#### Dialog: Continuation

Dialog box: Options

Tab: Equidistance

Entry field: Equidistant DP cycle = 2.000 ms (example value)

OK (close dialog box: Options)

OK (close dialog box: PROFIBUS properties)

OK (close dialog box: Properties - PROFIBUS interface ADI4 ...)

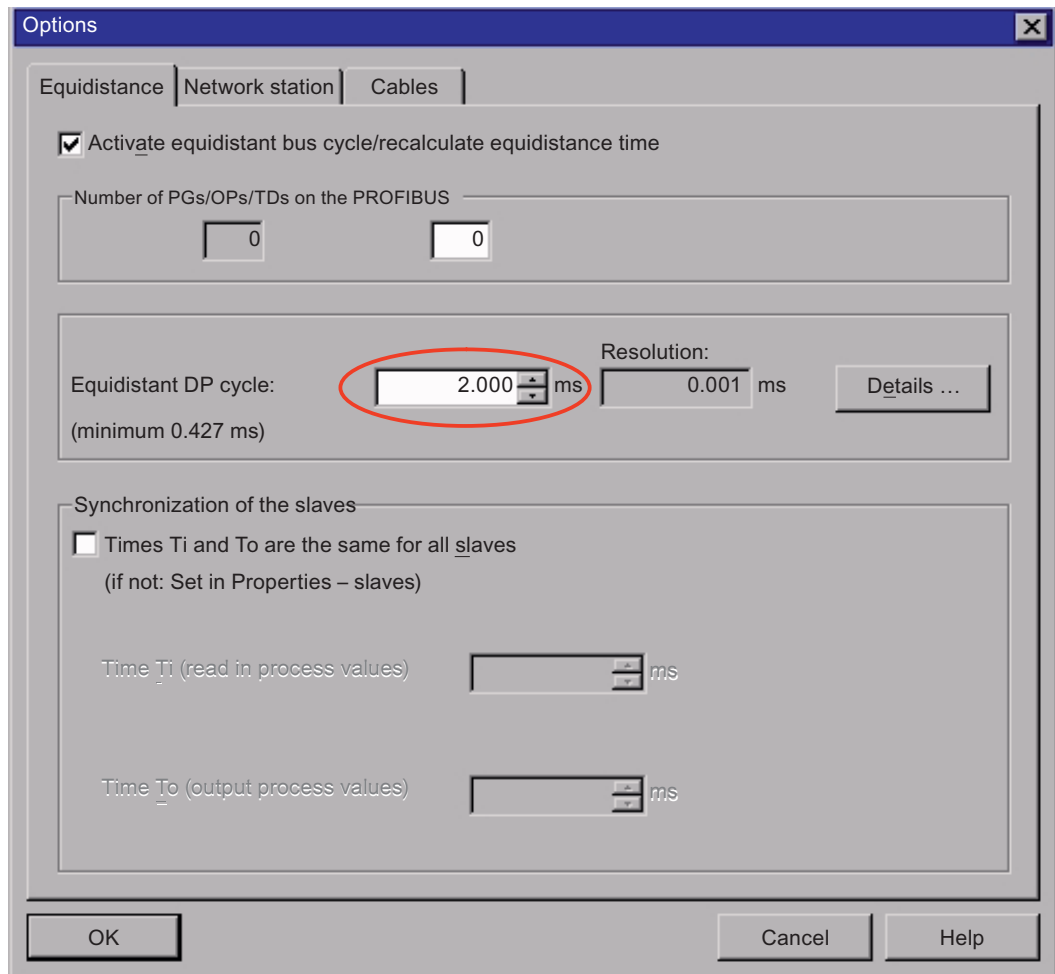

Figure 5-9 "Options" dialog box

### 5.10.5 DP cycle TDP

#### Procedure

In the "Factor" entry field of the "DP cycle (ms)", enter a value such that the resulting DP cycle is equal to the equidistant DP cycle.

#### Dialog: Start

Dialog: DP slave properties

Tab: Isochronous operation

Entry field: Factor = 16 (example value)

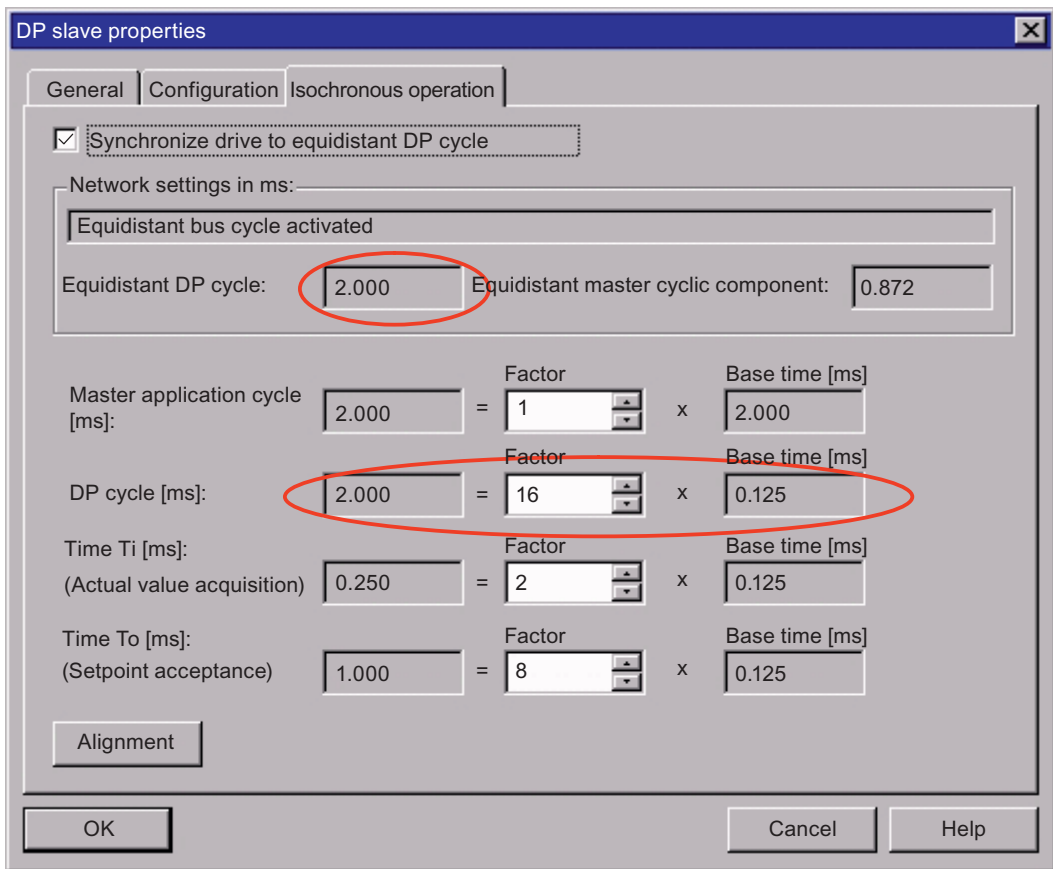

Figure 5-10 "DP Slave Properties" dialog box

**Note**

The DP cycle time ("DP cycle" parameter) of the ADI4 DP slave must be set to the same value as the DP cycle time setting for the DP master ("Equidistant DP cycle" parameter):

**DP cycle = equidistant DP cycle**

**See also**

Boundary conditions (Page 78)

## 5.10.6 Master application cycle T<sub>MAPC</sub>

### Introduction

The "Master application cycle T<sub>MAPC</sub>" parameter specifies the integer ratio between the cycle time of the master application (position controller) and the equidistant DP cycle.

Using ratios other than 1:1, the dead times of the position controller can be reduced if control hardware with a lower performance is being used.

---

#### Note

(SINUMERIK 840Di sl, SINUMERIK 840D sl)

The ratio between master application cycle T<sub>MAC</sub> and DP cycle time T<sub>DP</sub> **must** be 1:1.

(SINUMERIK 802D sl)

The ratio between master application cycle T<sub>MAC</sub> and DP cycle time T<sub>DP</sub> **can** be set to a ratio other than 1:1.

---

### Procedure

In the entry field for the factor of the "Master application cycle [ms]", enter a value such that the required time ratio is achieved.

### Dialog: Continuation

Dialog: DP slave properties

Tab: Isochronous mode

Entry field: Factor = 1 (example value)

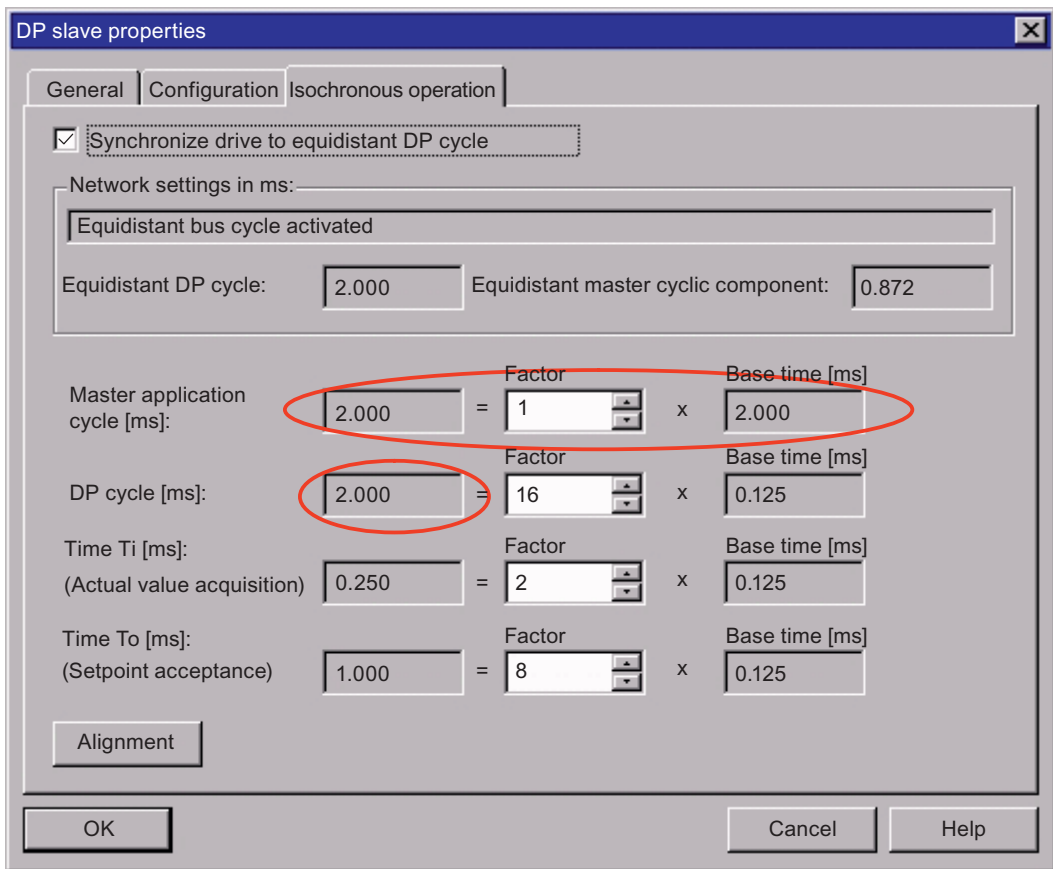

Figure 5-11 Dialog: DP slave properties

Sequence,  $T_{MAPC} : T_{DP} = 1 : 1$

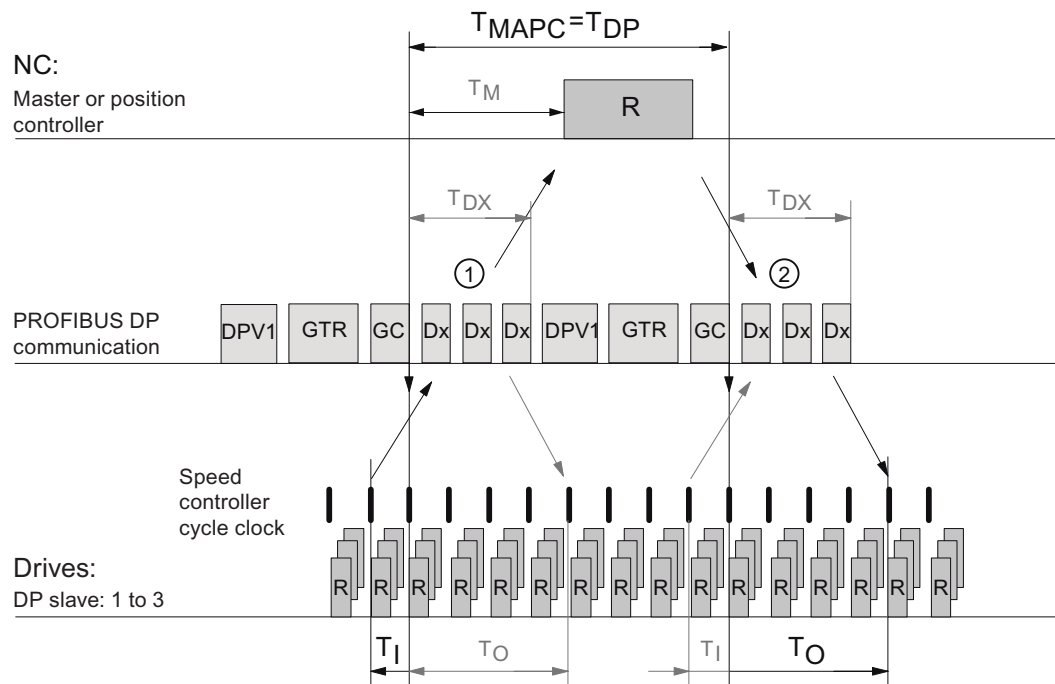

Figure 5-12 Example: optimized DP cycle with  $T_{MAPC} : T_{DP} = 1 : 1$

Sequence,  $T_{MAPC} : T_{DP} = 2 : 1$

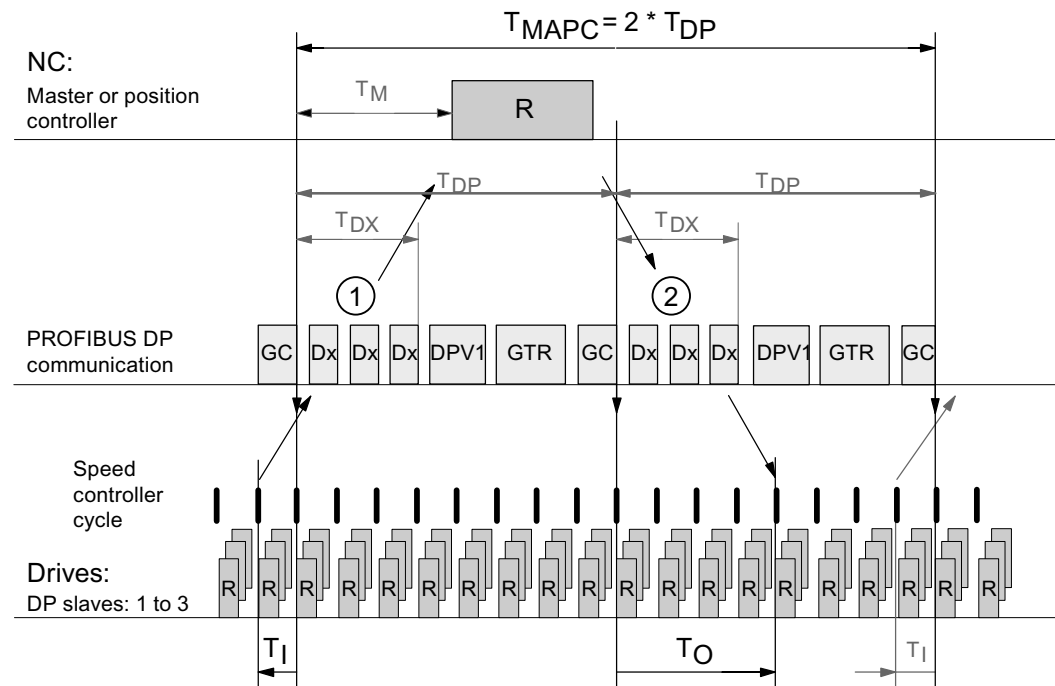

Figure 5-13 Example: optimized DP cycle with  $T_{MAPC} : T_{DP} = 2 : 1$

$T_{MAPC}$	Master application cycle: Position controller clock cycle
$T_{DP}$	DP cycle time: DP cycle time
$T_{DX}$	Data exchange time: Total transfer time for all DP slaves
$T_M$	Master time: Offset of the start time for NC position control
$T_i$	Input time: Time of the actual value acquisition. The actual values are transferred to the DP master in the <b>next</b> DP cycle.
$T_o$	Output time: Time of the setpoint acceptance. The setpoints were generated by the DP master application in the <b>previous</b> DP cycle.
GC	Global control telegram (broadcast telegram) for cyclic synchronization of the equidistance between the DP master and DP slaves
R	Computation time for speed or position controller
Dx	Net data exchange between the DP master and DP slaves
DPV1	After cyclic communication, an acyclic service is sent, if the token holding time $T_{TH}$ has not yet been exceeded. $T_{TH}$ is calculated by the engineering system.
GTR	GAP, TOKEN, RESERVE: GAP: An attempt is made during GAP to accept new active stations. TOKEN: The token passing is either to itself or other masters. RESERVE: The reserve is used as an "active pause" for the station to send the token to itself until the equidistant cycle expires.
①	The actual values for the actual DP cycle / position controller cycle are transferred from the DP slave drives to the NC position controller.
②	The setpoints computed by the NC position controller are transferred to the DP slave drives.

**See also**

Boundary conditions (Page 78)

### 5.10.7 Actual value acquisition $T_i$

#### Introduction

The "Actual value acquisition  $T_i$ " parameter specifies the time when an ADI4 DP slave reads in the actual values (actual position value).

It is recommended to specify the same time for the actual value acquisition  $T_i$  for all ADI4 DP slaves. Special attention must be paid to this if axes of different ADI4 DP slaves move according to interpolation on a common path.

#### Procedure

Enter the required value in the entry field for the factor of the actual value acquisition.



Dialog: Start

Dialog: DP slave properties

Tab: Isochronous operation

Entry field: Factor = 2 (example value)

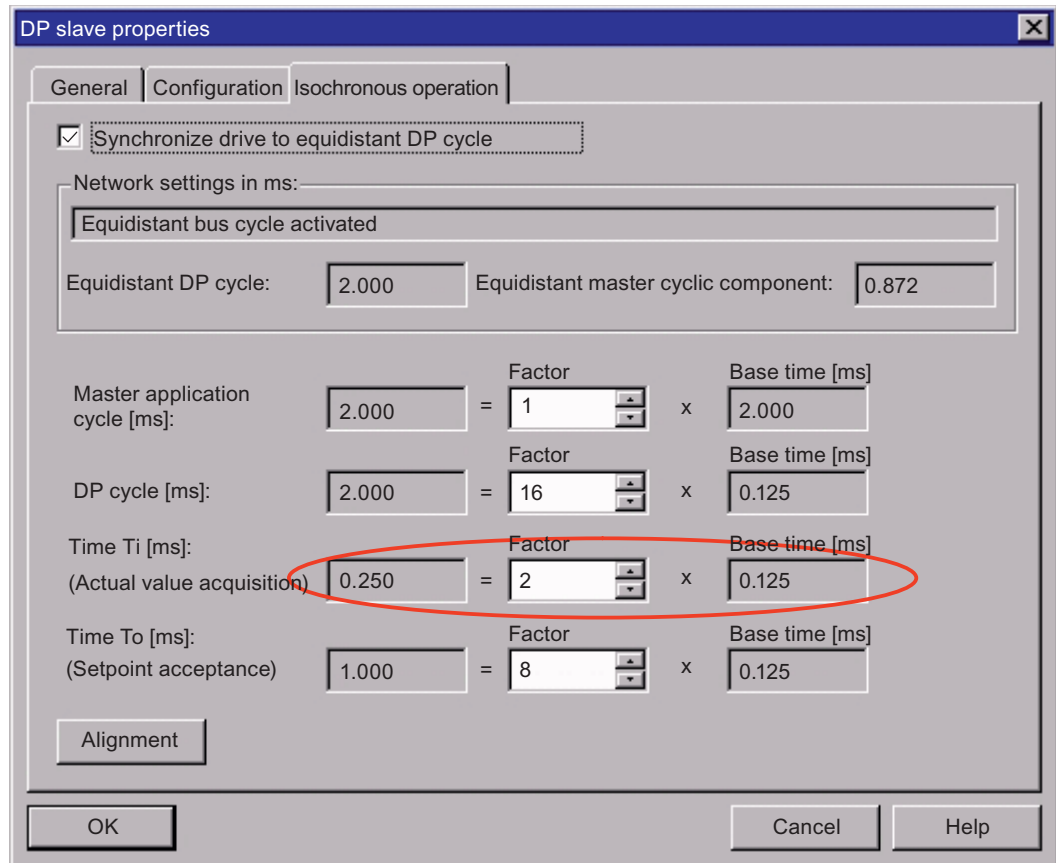

Figure 5-14 "DP Slave Properties" dialog box

**Note**

The following condition must be observed for the time of actual value acquisition  $T_i$ :

$$\text{Base time} \leq \text{actual value acquisition} \leq \text{DP cycle}$$

**See also**

Boundary conditions (Page 78)

## 5.10.8 Setpoint acceptance $T_o$

### Introduction

The "Setpoint acceptance  $T_o$ " parameter specifies the time when the ADI4 DP slave receives the speed setpoint from the position controller.

It is recommended that setpoint acceptance time  $T_o$  be the same for all ADI4 DP slaves, particularly if axes are interpolated together.

### Procedure

Enter the required value in the entry field for the factor of the setpoint acceptance.

### Dialog: Start

Dialog: DP slave properties

Tab: Isochronous operation

Entry field: Factor = 8 (example value)

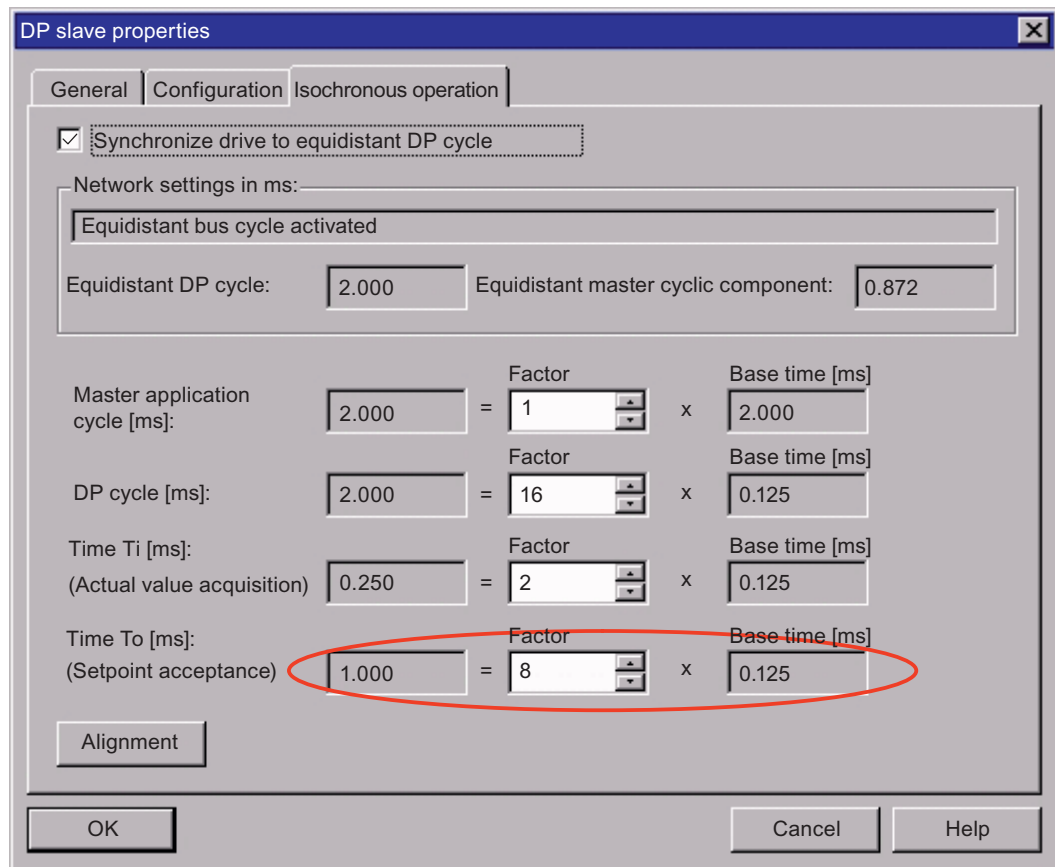

Figure 5-15 "DP Slave Properties" dialog box

**Note**

The following condition must be observed for the time of setpoint acceptance  $T_o$ :

**Equidistant master cyclic component + base time  $\leq$  setpoint acceptance  $\leq$  DP cycle**

**See also**

Boundary conditions (Page 78)

**5.10.9 Alignment****Procedure**

The alignment is used to transfer the values of the current ADI4 DP slave displayed in the "Isochronous operation" tab to all the other ADI4 DP slaves of the configuration.

Dialog: End

Dialog: DP slave properties

Tab: Isochronous operation

Button: Alignment

OK

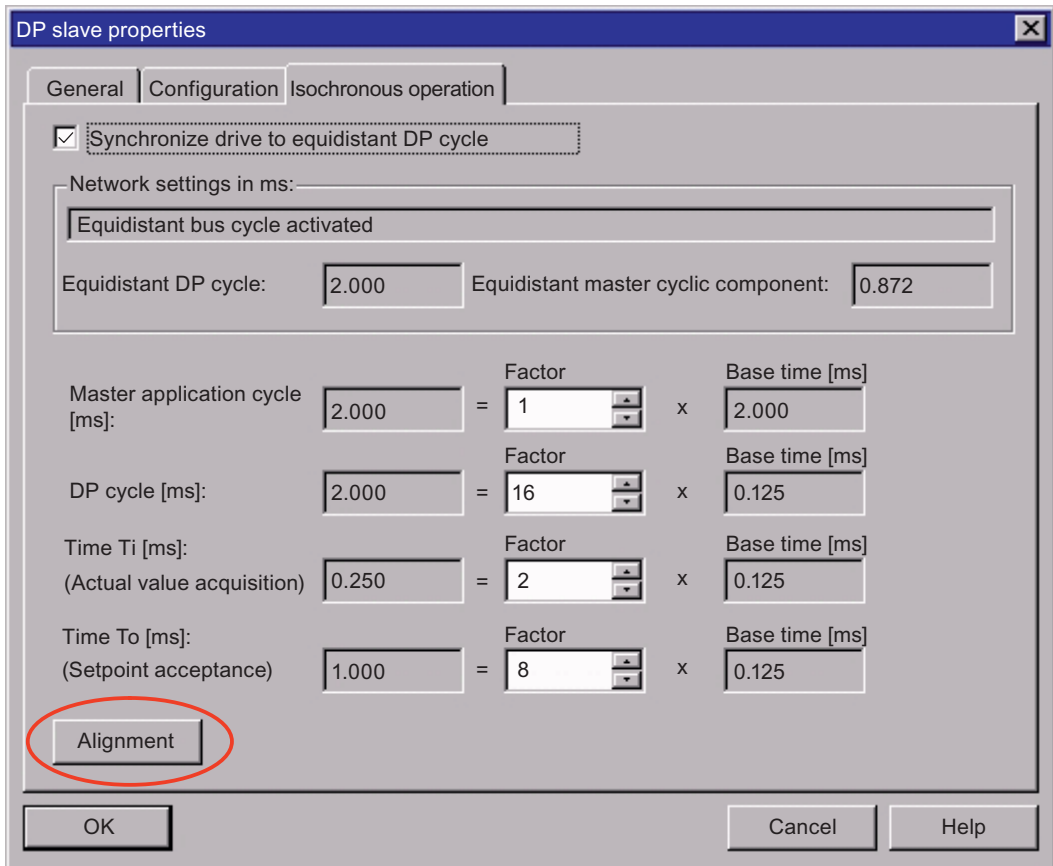

Figure 5-16 "DP Slave Properties" dialog box

---

**Note**

If an S7 project includes different equidistant DP slave types, such as different SIMODRIVE drives, ADI4, etc., the following parameter settings must be made for each DP slave type as described above, and an alignment must be performed:

- Equidistant DP cycle  $T_{DP}$
- Master application cycle  $T_{MAPC}$
- Actual value acquisition  $T_i$
- Setpoint acceptance  $T_o$

The alignment only transfers the values displayed in the "Isochronous operation" tab to the DP slaves **of the same** type.

---

The alignment concludes the parameter assignment of all ADI4 DP slaves with respect to the DP communication.

### 5.10.10 Boundary conditions

#### ADI4 from MLFB: 6FC5 211-0BA01-0AA1

The following boundary conditions must be observed when making the final parameter assignment of the equidistant DP cycle in conjunction with ADI4 from the following MLFB onwards: 6FC5 211-0BA01-0AA1:

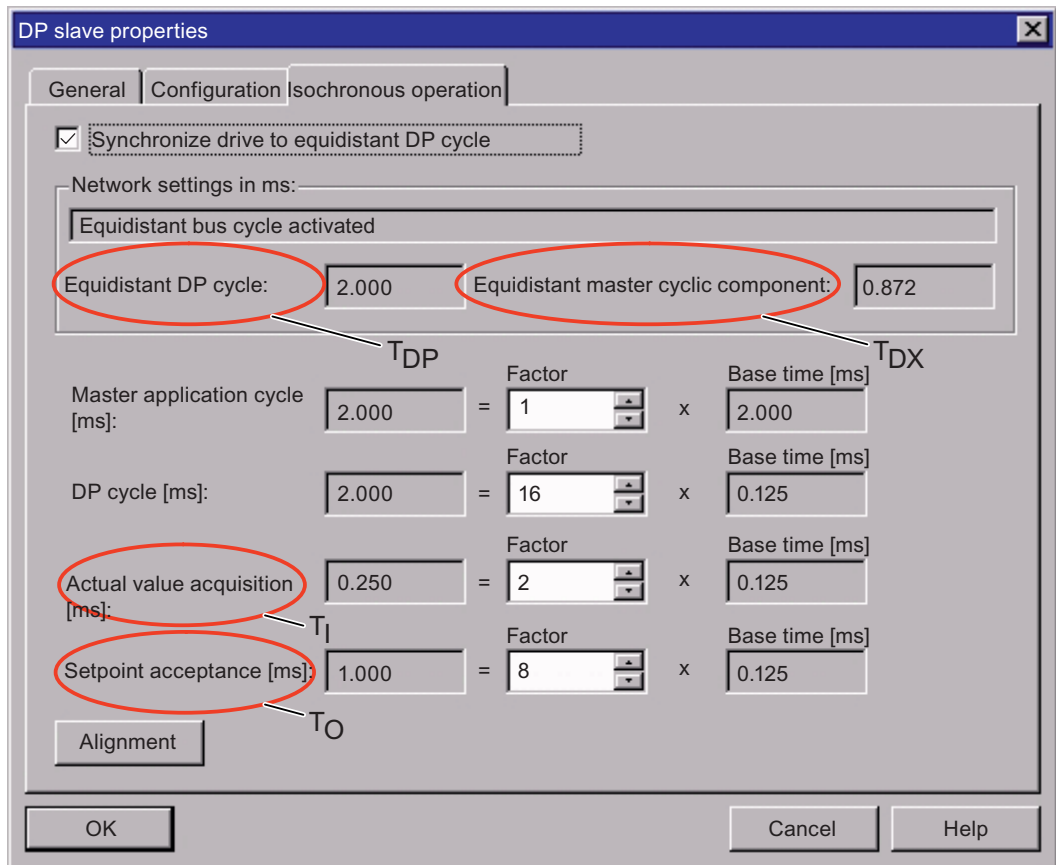

Figure 5-17 Section of the "DP Slave Properties" dialog box

1. Equidistant DP cycle ( $T_{DP}$ )
  - $T_{DP} = 2 * n * 125 \text{ us}$ ;
  - with  $n \geq 4$  ( $\Rightarrow$  minimum  $T_{DP} = 1 \text{ ms}$ )
2. Setpoint acceptance ( $T_o$ )
  - $(T_{DX} + 125 \text{ us}) \leq T_o < T_{DP}$ ;
  - with rounded variable  $T_{DX} = T_{DX}$ , rounded to an integer multiple of 125 us
3. Actual value acquisition ( $T_i$ )
  - $250 \text{ us} \leq T_i \leq 625 \text{ us}$
4.  $T_i$  and  $T_o$  cannot be in the same 125 us cycle clock
  - $\Delta T \neq 0$ ; with  $\Delta T = T_{DP} - T_i - T_o$

5. If  $T_o == (T_{DP} - 125 \text{ us})$

Then for  $T_i$ , the following must apply:  $T_i > 3 * 125 \text{ us}$

6. If  $T_o == (T_{DX} + 125 \text{ us})$

Then for  $(T_i + T_o)$ , the following must apply:  $(T_i + T_o) \neq (T_{DP} + 125 \text{ us})$

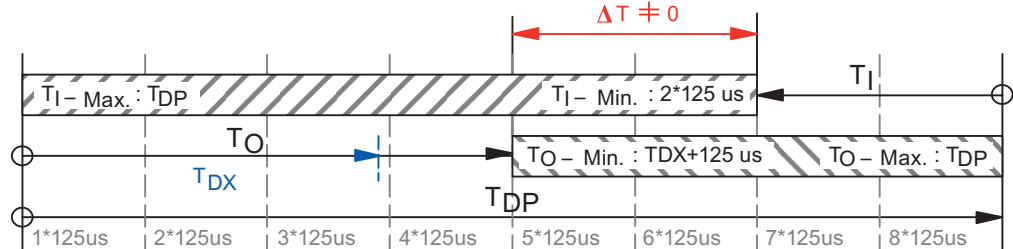

Figure 5-18 Graphic illustration of the boundary conditions

## Typical parameter values

Equidistant DP cycle ( $T_{DP}$ )	2.000 ms
Actual value acquisition ( $T_i$ )	0.250 ms
Setpoint acceptance ( $T_o$ )	1.000 ms

### Note

The ADI4 DP slaves

- Order number (MLFB): 6FC5 211-0BA01-0AA0
- Order number (MLFB): 6FC5 211-0BA01-0AA1 or ...0AA2

manifest a different behavior for a parameter assignment deviating from the boundary conditions indicated above for actual value acquisition ( $T_i$ ) and setpoint acceptance ( $T_o$ ).

- ADI4 DP slave with MLFB ...-0AA0  
If parameters are assigned that deviate from the boundary conditions indicated above, they are ignored by this ADI4 DP slave, as parameters are fixed internally. The ADI4 DP slave establishes cyclic communication with the DP master using values that differ from the parameterized preset values without an error message.
- ADI4 DP slave with MLFB ...0AA1 or ...0AA2  
If parameters are assigned that deviate from the boundary conditions indicated above and these parameters are downloaded to the ADI4 DP slave, the ADI4 DP slave does **not** establish cyclic communication with the DP master.





## Further information

### 6.1 Wiring of drive ready signals

In order that a drive connected to the ADI4 can be switched-on via the S7 function block FB 401 (MC\_POWER), the ready signal of the drive must be connected to one of the digital inputs, "Drive Ready" signal, axis x (DRVx\_RDY), interface (X6-2) of the ADI4.

The ready signal must still be available at the ADI4 input even after the drive has been switched on.

---

#### Note

##### Drives without ready signal

If a ready signal is not available for a drive, then 24 V can be statically assigned to the corresponding digital ready signal input "Drive Ready" axis x (DRVx\_RDY) of the ADI4. However, this approach has the disadvantage that when a drive fails, this is no longer detected by the S7 function block FB 401 (MC\_POWER). FB 401 returns the status "TRUE" at its output even after a drive failure.

---

### 6.2 Supported SSI encoder formats

SSI encoders with the following formats are supported:

1. "Christmas tree" formats whose net data length (MsgLength, see Chapter "Encoder type (Page 53)") is the **same** as the number of significant data bits:
  - 25 bit with 12-bit multiturn and 13-bit singleturn information (MsgLength = 25)
  - 21 bit with 8-bit multiturn and 13-bit singleturn information (MsgLength = 21)
  - 13 bit with 13-bit singleturn information (MsgLength = 13)
2. Left-justified "Christmas tree" formats whose net data length (MsgLength) is **not equal** to the number of significant data bits:
  - 25 bit with 12-bit multiturn and 12-bit singleturn information (MsgLength = 24)
  - 21 bit with 8-bit multiturn and 12-bit singleturn information (MsgLength = 20)
  - 13 bit with 12-bit singleturn information (MsgLength = 12)

#### Note

SSI encoders with net data lengths not equal to the number of significant data bits can only be used if the complete net data length does not have to be read!

3. All right-justified "Christmas tree" formats, which fulfill the condition under 1.

Examples for Christmas tree formats that are supported

25-bit multiturn encoder, Christmas tree format, multiturn: 12-bit, singleturn: 13 bit $\Rightarrow$ resolution: $2^{13} = 8192$																								
Multiturn												Singleturn												
SSI Cycle Number																								
1	2	3	4	5	6	7	8	9	10	11	12	13	14	15	16	17	18	19	20	21	22	23	24	25
M12	M11	M10	M9	M8	M7	M6	M5	M4	M3	M2	M1	S1	S2	S3	S4	S5	S6	S7	S8	S9	S10	S11	S12	S13
25-bit multiturn encoder, Christmas tree format (multiturn: 12-bit, singleturn: 12 bit $\Rightarrow$ resolution: $2^{13} = 8192$ )																								
Multiturn												Singleturn												
SSI Cycle Number																								
1	2	3	4	5	6	7	8	9	10	11	12	13	14	15	16	17	18	19	20	21	22	23	24	25
M12	M11	M10	M9	M8	M7	M6	M5	M4	M3	M2	M1	S1	S2	S3	S4	S5	S6	S7	S8	S9	S10	S11	S12	0
25-bit multiturn encoder, Christmas tree format (multiturn: 8-bit, singleturn: 12 bit $\Rightarrow$ resolution: $2^{13} = 8192$ )																								
Multiturn												Singleturn												
SSI Cycle Number																								
1	2	3	4	5	6	7	8	9	10	11	12	13	14	15	16	17	18	19	20	21	22	23	24	25
0	0	0	0	M8	M7	M6	M5	M4	M3	M2	M1	S1	S2	S3	S4	S5	S6	S7	S8	S9	S10	S11	S12	0
25-bit multiturn encoder, Christmas tree format (multiturn: 9-bit, singleturn: 13 bit $\Rightarrow$ resolution: $2^{13} = 8192$ )																								
Multiturn												Singleturn												
SSI Cycle Number																								
1	2	3	4	5	6	7	8	9	10	11	12	13	14	15	16	17	18	19	20	21	22	23	24	25
0	0	0	M9	M8	M7	M6	M5	M4	M3	M2	M1	S1	S2	S3	S4	S5	S6	S7	S8	S9	S10	S11	S12	S13
21-bit multiturn encoder, Christmas tree format (multiturn: 8-bit, singleturn: 13 bit $\Rightarrow$ resolution: $2^{13} = 8192$ )																								
Multiturn								Singleturn																
SSI Cycle Number																								
1	2	3	4	5	6	7	8	9	10	11	12	13	14	15	16	17	18	19	20	21				
M8	M7	M6	M5	M4	M3	M2	M1	S1	S2	S3	S4	S5	S6	S7	S8	S9	S10	S11	S12	S13				
13-bit singleturn encoder (left aligned) $\Rightarrow$ resolution: $2^{13} = 8192$																								
Singleturn																								
SSI Cycle Number																								
1	2	3	4	5	6	7	8	9	10	11	12	13												
S1	S2	S3	S4	S5	S6	S7	S8	S9	S10	S11	S12	S13												

6.3 Linear encoder with distance-coded zero marks / reference marks

Machine data

The following machine data must be set for the commissioning of the measuring system of a machine axis with linear encoder and distance-coded zero marks / reference marks:

Number	Identifier: \$MA_	Meaning
30240	ENC_TYPE	Encoder type (data transmission)
31000	ENC_IS_LINEAR	Encoder type (type of construction) Linear encoders

Number	Identifier: \$MA_	Meaning
31010	ENC_GRID_POINT_DIST	Signal period or scale division / EXE factor
31040	ENC_IS_DIRECT	Encoder mounting method: Direct measuring system
32100	AX_MOTION_DIR	Traversing direction (does not affect the control sense)
32110	ENC_FEEDBACK_POL	Encoder value polarity (affects the control sense)
34090	REFP_MOVE_DIST_CORR	Zero point/reference point offset The offset between the machine zero point and the first reference mark.
34200	ENC_REFP_MODE	Homing mode
34300	ENC_REFP_MARKER_DIST	Reference mark distance (basic distance)
34310	ENC_MARKER_INC	Interval between two reference marks Note Heidenhain: For all linear encoders with distance-coded zero marks / reference marks 20 µm
34320	ENC_INVERS	Orientation of the measuring system in relation to axis motion

## Example

The following example illustrates how the mounting conditions of the machine axis and linear encoder have to be taken into account in the machine data for the machine axis concerned.

Type of linear encoder with distance-coded zero marks / reference marks used:

Heidenhain: LS 476 C

Technical characteristics (extract)	Value
Measuring length	270 mm
Reference mark distance	20 mm
Signal period of the incremental signals with scale division of 0.02 and integrated interpolation: 5x	0.004 mm
Distance between two reference marks (specific to Heidenhain)	0.02 mm

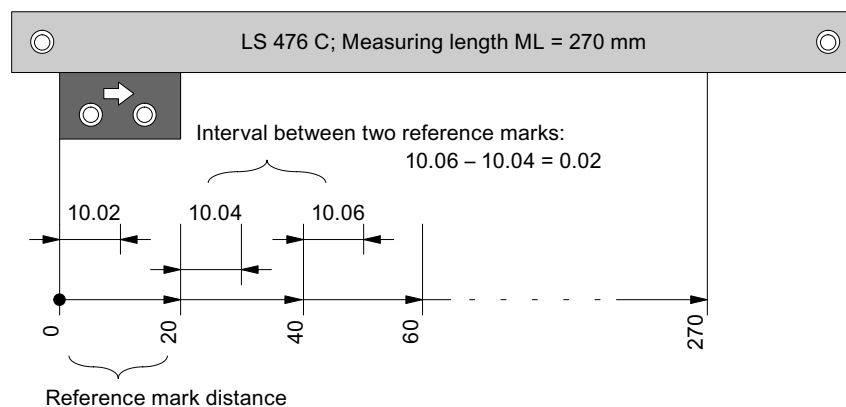

Figure 6-1 Linear encoder: LS 476 C

6.3 Linear encoder with distance-coded zero marks / reference marks

Because of the various possibilities regarding the orientation of the machine axis and linear encoder (same sense / opposite sense), it is necessary to distinguish between two scenarios.

Machine data remains the same in both cases:

Number	Identifier: \$MA_	Value
30240	ENC_TYPE	2
31000	ENC_IS_LINEAR	1
31010 *	ENC_GRID_POINT_DIST	0.004
31040	ENC_IS_DIRECT	1
34200	ENC_REFP_MODE	3
34300 *	ENC_REFP_MARKER_DIST	20
34310 *	ENC_MARKER_INC	0.02
*) Technical characteristics of the encoder		

Scenario 1: Equidirectional orientation

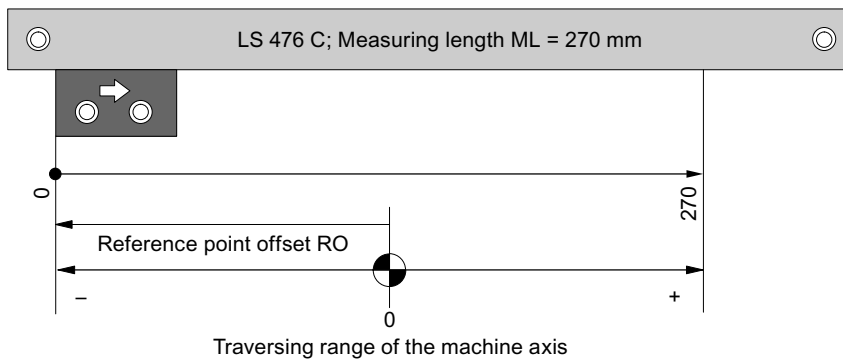

Figure 6-2 Machine axis with linear encoder: Equidirectional orientation

Orientation-dependent machine data

32100	AX_MOTION_DIR	1
32110	ENC_FEEDBACK_POL	1
34090	REFP_MOVE_DIST_CORR	RO
34320	ENC_INVERS	0

**Scenario 2: Inverse orientation**

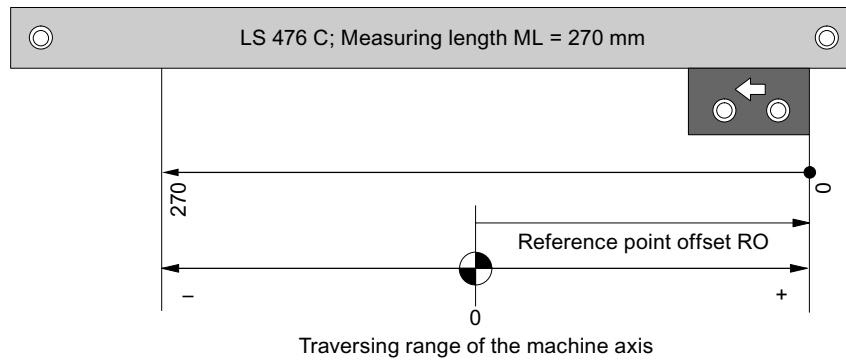

Figure 6-3 Machine axis with linear encoder: Inverse orientation

Orientation-dependent machine data

32100	AX_MOTION_DIR	1
32110	ENC_FEEDBACK_POL	-1
34090	REFP_MOVE_DIST_CORR	RO
34320	ENC_INVERS	1



# Index

(

- (S2): PROFIBUS address, 22
- (SINUMERIK 802D sl), 29, 32, 52, 69, 79
- (SINUMERIK 840D sl), 42, 54, 57, 69
- (SINUMERIK 840Di sl), 27, 41, 54
- (SINUMERIK), 56
- (X1): External power supply
  - Connection,
  - Connection cables,
  - Supply voltage,
- (X2): PROFIBUS DP
  - Cables,
  - Connection,
  - Connectors,
  - Data rate,
- (X3): Analog setpoint interface
  - Connection,
  - Pin assignment,
  - Prefabricated cables,
  - Resolution of setpoint outputs,
- (X4-1/X4-2/X5-1/X5-2)
  - Encoder interfaces: Connectable measuring systems,
  - Encoder interfaces: Connection,
  - Encoder interfaces: Encoder supply voltages,
  - Encoder interfaces: Maximum cable lengths,
  - Encoder interfaces: Pin assignment,
  - Encoder interfaces: Prefabricated cables,
- (X6-1)
  - Digital outputs: Connecting cables,
  - Digital outputs: Connection,
  - Digital outputs: General electrical properties,
  - Digital outputs: Relay contact: Ready signal,
  - Digital outputs: Supply voltage,
- (X6-2)
  - Digital inputs: Connecting cables,
  - Digital inputs: Connection,
  - Digital inputs: External supply voltage P24OUText,
  - Digital inputs: General electrical properties,
  - Digital inputs: Internal supply voltage P24OUT,

## 6

- 611U conformant mode, 49, 52, 58
  - None, 59, 60
  - with, 60, 61

## A

- Activating
  - Equidistant cycle, 63
- Actual encoder value
  - Additional, 50
- Actual value acquisition, 72
- Additional encoder actual value, 50
- ADI4 DP slave, 42
- ADI4 module, 35
- Alignment, 75

## B

- Boundary conditions, 41, 61, 78
  - Encoders without axes, 61
  - External encoder interface, 61
  - On-the-fly measurement, 61
  - Probe, 61
  - SINUMERIK 802D sl, 79
  - Speed actual value, 61

## C

- Cable routing, 35
- Cables
  - PROFIBUS DP, 21
- Configuration, 44
- Connectable measuring systems
  - Encoder interfaces, 27
- Connecting cable
  - Digital inputs, 33
  - Digital outputs, 31
- Connection
  - Analog setpoint interface, 22
  - Digital inputs, 31
  - Digital outputs, 28
  - Encoder interfaces, 24
  - PROFIBUS DP, 21
- Connection cables
  - External power supply, 20
- Connectors
  - PROFIBUS DP, 21
- Consistency, 51
- Controller commissioning, 82

## D

- Data rate
  - PROFIBUS DP, 21
- Diagnostic LEDs
  - EXCHANGE, 34
  - OVTEMP, 34
  - POWER, 34
  - READY, 34
- Digital inputs, 35
  - Interface, 31
- Digital outputs, 35
  - Interface, 28
- Direction of rotation signal, 55
- Direction of rotation signals, 56
- Distance-coded zero marks
  - SINUMERIK 840Di sl, 82
- DP cycle TDP, 67
- DP cycle time, 72
- DP slave SINAMICS S120, 42

## E

- Encoder control word, 49
- Encoder error, 49
- Encoder interfaces, 24
  - Maximum cable lengths, 25
- Encoder supply voltages
  - Encoder interfaces, 26
- Encoder type, 53
  - SSI, 54
  - TTL, 53
- Encoder type not available, 53
- Encoder zero mark, 58, 59, 60
- Encoders without axes, 61
- Entering
  - Message frame type, 46
  - PROFIBUS address, 45
- Equidistant DP cycle, 66
  - Activating, 63
- Equidistant master cycl. proportion, 64
- Equipotential bonding, 12
- Error codes
  - Gx\_XIST2, 50
- Essential features, 17
- EXCHANGE, 34
- External encoder interface, 61
- External supply voltage P24OUText
  - Digital inputs, 33
- External zero mark, 58, 60

## F

- Features
  - Essential, 17
- Find reference mark, 49, 58
- Fine resolution, 57
  - SINUMERIK 840Di sl, 57
- Firmware version, 17
- Function parameters, 52
  - SINUMERIK 802D sl, 52

## G

- GAP, 72
- GC, 72
- General, 17
- General electrical properties
  - Digital inputs, 34
  - Digital outputs, 30
- Global Control telegram, 72
- Grounding, 37
- Grounding connections, 12
- Gx\_STW, 49
- Gx\_XIST2, 50

## H

- Homing
  - Encoder zero mark, 59
  - External zero mark, 60

## I

- I/O addresses, 51
- Input time, 72
- Installation, 34
- Interface
  - (S2): PROFIBUS address, 22
  - (X1): External power supply, 20
  - (X2): PROFIBUS DP, 21
  - (X3): Analog setpoint interface, 22
- Interface
  - (X4-1/X4-2/X5-1/X5-2): Encoder interfaces, 24
- Interface
  - (X6-1): Digital outputs, 28
- Interface
  - (X6-1): Digital outputs, 28
- Interface
  - (X6-2): Digital inputs, 31
- Internal supply voltage P24OUT
  - Digital inputs, 32



**L**

Linear encoders  
SINUMERIK, 82

**M**

M3, spindle CW, 56  
M4, spindle CCW, 56  
M5, spindle stop, 56  
Master application cycle, 69, 72  
MD34990  
SINUMERIK 840D sl, 54  
SINUMERIK 840Di sl, 54  
Message frame structure, 48  
Message frame type  
Entering, 46  
MLFB  
6FC5 211-0BA01-0AA1,

**N**

Noise immunity, 13

**O**

On-the-fly measurement, 61  
Order number, 17  
Output time, 72  
Overview of connections, 17  
OVTEMP, 34

**P**

Parameter assignment, 41  
Parameter assignment of the DP communication, 62  
Parameter assignment sequence, 43  
Pin assignment  
Analog setpoint interface, 22  
Encoder interfaces, 24  
POWER, 34  
Power cables, 13  
Power supply, 35  
Preconditions  
SINUMERIK 840D sl, 42  
SINUMERIK 840Di sl, 41  
Prefabricated cables  
Analog setpoint interface, 23  
Encoder interfaces, 25  
Probe, 61

PROFIBUS address, 22  
Entering, 45  
PROFIBUS DP parameter assignment, 43  
PROFIBUS parameters, 45  
PROFINET, 16  
Properties, 17

**R**

READY, 34  
Reference marks  
SINUMERIK 840Di sl, 82  
Relay contact  
Digital outputs, 30  
RESERVE, 72  
Reserved bits for fine resolution, 57  
SINUMERIK 840Di sl, 57  
Resolution of setpoint outputs, 23

**S**

Safe operation, 9  
Sequence  
Parameter assignment, 43  
Setpoint transfer, 74  
Shielded signal cables, 12  
Shutdown delay, 56  
Shutdown ramp, 56  
Signal cables, 13  
Sign-of-life failures, 57  
SIMATIC STEP 7, 41, 42  
SINUMERIK  
Linear encoders, 82  
SINUMERIK 802D sl, 79  
SINUMERIK 840Di sl  
Reference marks, 82  
SlaveOM, 42  
Smoothing time constant  
SINUMERIK 840D sl, 54  
SINUMERIK 840Di sl, 54  
Speed actual value, 61  
Supply voltage  
Digital outputs, 29  
External power supply, 21  
Supply voltages (+24 VDC), 36

**T**

TDP, 67  
TDX, 64  
Ti, 72

TMAPC, 69, 72  
To, 74  
TOKEN, 72  
Tolerable sign-of-life failures, 57  
Total length, 51

## **U**

Unipolar motor, 55  
    SINUMERIK, 56  
Unipolar spindle, 55  
    SINUMERIK, 56