

PCS 7 Standard Architectures

SIMATIC PCS 7 V8.0 SP1

[Application description](#) • January 2014

Applications & Tools

Answers for industry.

SIEMENS

Siemens Industry Online Support

This article is taken from the Siemens Industry Online Support. The following link takes you directly to the download page for this document:

<http://support.automation.siemens.com/WW/view/en/32201963>

Security information

Siemens provides products and solutions with industrial security functions that support the secure operation of plants, solutions, machines, equipment and/or networks. They are important components in a holistic industrial security concept. With this in mind, Siemens' products and solutions undergo continuous development. Siemens recommends strongly that you regularly check for product updates.

For the secure operation of Siemens products and solutions, it is necessary to take suitable preventive action (e.g. cell protection concept) and integrate each component into a holistic, state-of-the-art industrial security concept. Third-party products that may be in use should also be considered. For more information about industrial security, visit <http://www.siemens.com/industrialsecurity>.

To stay informed about product updates as they occur, sign up for a product-specific newsletter. For more information, visit <http://support.automation.siemens.com>.

Warranty and liability

Note

The Application Examples are not binding and do not claim to be complete regarding the circuits shown, equipping and any eventuality. The Application Examples do not represent customer-specific solutions. They are only intended to provide support for typical applications. You are responsible for ensuring that the described products are used correctly. These application examples do not relieve you of the responsibility to use safe practices in application, installation, operation and maintenance. When using these Application Examples, you recognize that we cannot be made liable for any damage/claims beyond the liability clause described. We reserve the right to make changes to these Application Examples at any time without prior notice. If there are any deviations between the recommendations provided in these application examples and other Siemens publications – e.g. Catalogs – the contents of the other documents have priority.

We do not accept any liability for the information contained in this document.

Any claims against us – based on whatever legal reason – resulting from the use of the examples, information, programs, engineering and performance data etc., described in this Application Example shall be excluded. Such an exclusion shall not apply in the case of mandatory liability, e.g. under the German Product Liability Act ("Produkthaftungsgesetz"), in case of intent, gross negligence, or injury of life, body or health, guarantee for the quality of a product, fraudulent concealment of a deficiency or breach of a condition which goes to the root of the contract ("wesentliche Vertragspflichten"). The damages for a breach of a substantial contractual obligation are, however, limited to the foreseeable damage, typical for the type of contract, except in the event of intent or gross negligence or injury to life, body or health. The above provisions do not imply a change of the burden of proof to your detriment.

Any form of duplication or distribution of these Application Examples or excerpts hereof is prohibited without the expressed consent of Siemens Industry Sector.

Security information

Siemens provides products and solutions with industrial security functions that support the secure operation of plants, solutions, machines, equipment and/or networks. They are important components in a holistic industrial security concept. With this in mind, Siemens' products and solutions undergo continuous development. Siemens recommends strongly that you regularly check for product updates.

For the secure operation of Siemens products and solutions, it is necessary to take suitable preventive action (e.g. cell protection concept) and integrate each component into a holistic, state-of-the-art industrial security concept. Third-party products that may be in use should also be considered. For more information about industrial security, visit <http://www.siemens.com/industrialsecurity>.

To stay informed about product updates as they occur, sign up for a product-specific newsletter. For more information, visit <http://support.automation.siemens.com>.

Table of contents

	Warranty and liability	3
1	Introduction	7
2	Selection guide for the standard architectures.....	8
2.1	Entry-level systems (e.g. PCS 7 BOX RTX)	9
2.2	Single-user system	9
2.3	Multiple-user system	10
2.4	Client/server system	10
2.5	Client/Server System with several servers	11
3	Entry-level systems.....	12
3.1	Entry-level system	13
3.2	Separate ES in the entry-level system.....	15
3.3	Entry-level system with dual monitor	17
3.4	Entry-level SIMATIC PCS 7 BOX RTX as ES and OS Client	19
3.5	SIMATIC PCS 7 AS RTX system	21
4	Single-user system.....	23
4.1	Single-user system	24
4.2	Single-user station with dual monitor.....	26
4.3	Single-user station with web server.....	28
5	System with multiple OS single stations.....	31
5.1	Multiple OS single stations.....	32
5.2	Redundant OS single stations.....	35
5.3	Multiple OS single stations with dual monitor.....	38
5.4	Plain system configuration without OS server.....	41
6	Client/server system	43
6.1	Client/server	44
6.2	Client/server with operator control and monitoring on the ES and OS Server.....	47
6.3	Client/server operation on a server architecture	50
6.4	Client/server operation on a redundant server architecture.....	53
6.5	Redundant client/server	56
6.6	Client/server system with Web Server.....	59
6.7	Client/server system with DataMonitor server.....	62
6.8	Client/server system with terminal server	65
6.9	Client/server with dual monitor	68
6.10	Client/server system with multi-user engineering.....	71
7	Multi-server.....	74
7.1	Multi-server single bus architecture.....	75
7.2	Redundant multi-server bus architecture.....	78
8	SIMATIC BATCH.....	81
8.1	SIMATIC BATCH single-user station.....	82
8.2	SIMATIC BATCH single-user system in an OS client/server architecture	84
8.3	SIMATIC BATCH client/server	87
8.4	Separate SIMATIC BATCH Server.....	90
8.5	Redundant SIMATIC BATCH client/server architecture	92
8.6	SIMATIC BATCH multi-server.....	96

9	SIMATIC Route Control	99
9.1	SIMATIC Route Control single-user station	100
9.2	SIMATIC Route Control client/server architecture	103
9.3	Redundant SIMATIC Route Control client/server architecture	106
9.4	SIMATIC Route Control multi-server	110
10	SIMATIC Route Control and SIMATIC BATCH	113
10.1	SIMATIC Route Control and SIMATIC BATCH single-user station	114
10.2	SIMATIC Route Control and SIMATIC BATCH client/server	117
10.3	Redundant SIMATIC Route Control and SIMATIC BATCH client/server.....	120
10.4	SIMATIC Route Control and SIMATIC BATCH multi-server.....	124
11	Archiving	128
11.1	Client/server	129
11.2	Redundant OS Server and single Process Historian.....	132
11.3	Redundant OS Server and redundant Process Historian	136
11.4	Client/server system with StoragePlus	140
12	SIMATIC PDM	143
12.1	SIMATIC PDM stand-alone.....	145
12.2	SIMATIC PDM with SIMATIC Field PG at the system bus	147
12.3	SIMATIC PDM and PCS 7 Starter System	149
12.4	SIMATIC PDM and PCS 7 Single-user System	151
12.5	SIMATIC PDM and PCS 7 client/server system	154
12.6	SIMATIC PDM and non-SIMATIC S7 master	157
12.7	SIMATIC MS PDM.....	159
13	Asset management	161
13.1	Asset Management Starter System.....	162
13.2	Asset Management Single-user station	164
13.3	Asset Management Client/server	169
13.4	Asset Management Client/server with a single maintenance server	175
13.5	Redundant Asset Management Client/server	178
14	Fieldbus	184
14.1	Single DP-PA / DP-FF fieldbus	187
14.2	Single optical DP-PA / DP-FF fieldbus	190
14.3	Redundant DP-PA / DP-FF fieldbus	193
14.4	Redundant optical DP-PA / DP-FF fieldbus	196
14.5	PROFINET IO fieldbus of a single automation system.....	199
14.6	PROFINET IO fieldbus in a high-availability automation system	200
15	Network architecture	202
15.1	Star architectures	203
15.2	Fault-tolerant ring architectures.....	204
15.2.1	High speed ring fault tolerance.....	204
15.2.2	Ring connectivity, standby redundancy	205
15.3	Fault-tolerant ring architectures in fiber-optic cable	206
15.4	Electrical fault-tolerant ring architectures.....	208
15.5	(Double) redundant bus architectures	210
15.6	Fault-tolerant ring 1GB.....	212

Table of contents

15.7	Redundancy concept - system bus	214
15.7.1	Introduction	214
15.7.2	Single-user AS 41x-x-1H automation system	214
15.7.3	Redundant AS 410-5H automation system.....	217
15.8	Redundancy concept - terminal bus	221
15.8.1	Introduction	221
15.8.2	Redundant terminal bus.....	222
16	Safety Systems.....	225
16.1	Single-user station with Safety System	226
16.2	Client/server with Safety System.....	228
16.3	Client/server with redundant Safety System	231
17	Possibilities for data exchange.....	235
17.1	Client/server system and OpenPCS 7	236
17.2	Small client/server system and OpenPCS 7	239
17.3	Large client/server system and OpenPCS 7	242
18	AS-OS PO Count	246
18.1	Starter System with 250 process objects.....	248
18.2	Single-user System with 1000 process objects.....	250
18.3	Client/server system with 2000 process objects	252
18.4	Redundant client/server system with 3000 process objects	255
18.5	Multi-server System with 5000 process objects	258

1 Introduction

This document describes the architectures and components of SIMATIC PCS 7 in a basic structure. In addition to the mentioned architectures, various options and configured versions are also displayed. SIMATIC PCS 7 is a highly scalable process control system with numerous topologies that are based on redundancy as well as optional hardware and software features.

This document should help you by simplifying your choice:

- Architectures based on the number of users, inputs and outputs
- SIMATIC PCS 7 options, for example, SIMATIC BATCH, SIMATIC Route Control, Asset Management and Fieldbus
- Degree of system availability and network topologies

Note

For the sake of simplicity, the architectures shown in this document contain only the necessary basic licenses. In order to achieve the desired quantity structure, in addition to the basic licenses you must also take into account the corresponding set of volume licenses.

Figure 1-1: Caption

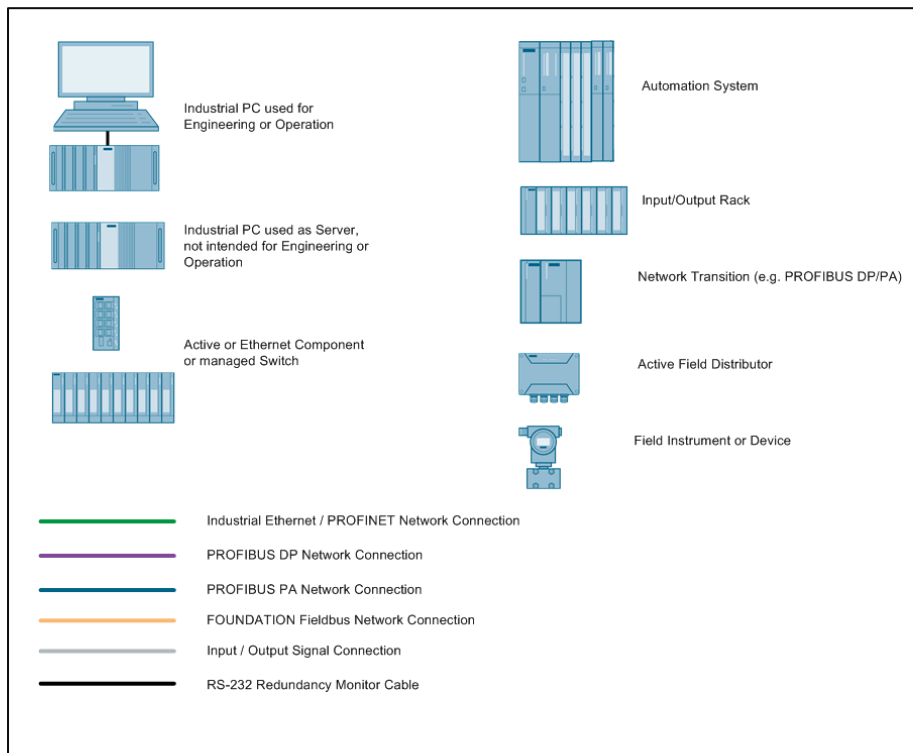

Note

This caption shows merely schematic representations of the components and does not show the real picture of the individual components, as their shape, the terminal type and the modular structure of the selected components may be different.

2 Selection guide for the standard architectures

Selected SIMATIC components are used to create a DCS with a scalable and flexible architecture. The choice of a system architecture that meets your requirements and your demands on the required properties, such as size, availability and number of fulfilled operator stations, is a process that is supported by a selection guide for the standard architecture.

As a result, you receive an overview of the selected architecture and its components. You also receive instructions for generating a bill of material.

SIMATIC PCS 7 enables a seamless extension of your system with full use of existing equipment. Both software and hardware components satisfy this requirement equally.

When choosing your architecture, you should first determine the following system criteria:

1. Number of inputs and outputs for the process
2. Number of operators that work with the system

Number of inputs and outputs connected to the system

To determine the number of signals entering or leaving the system, you must consider several media:



1. The number digital and analog I/O to be installed.
2. The number of variables (boolean, integer or floating point) exchanged between the PCS 7 System and external systems such as PLCs, serial interfaces, etc., and running on protocols such as Modbus, PROFIBUS, PROFINET or Ethernet.
3. Inputs and outputs that are read or written via bus systems, such as AS-Interface.

Number of persons operating the system

The chosen architecture must be designed for the total number of users, operators and engineers who eventually work on the system. This number determines the required number of individual workplaces.

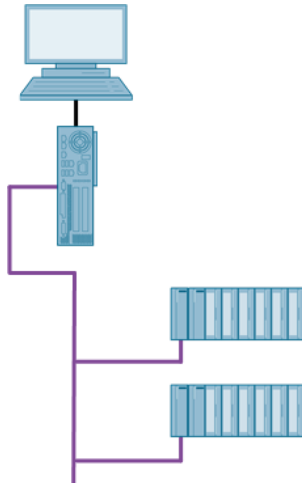

2.1 Entry-level systems (e.g. PCS 7 BOX RTX)

Table 2-1

Number of inputs/outputs:	
50 - 300	
Number of operators:	
one to two	
	

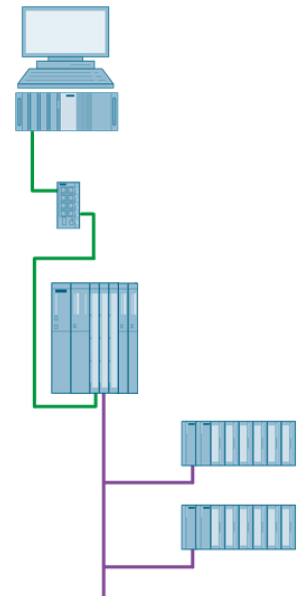

2.2 Single-user system

Table 2-2

Number of inputs/outputs:	
250 – 600	
Number of operators:	
one to two	
	

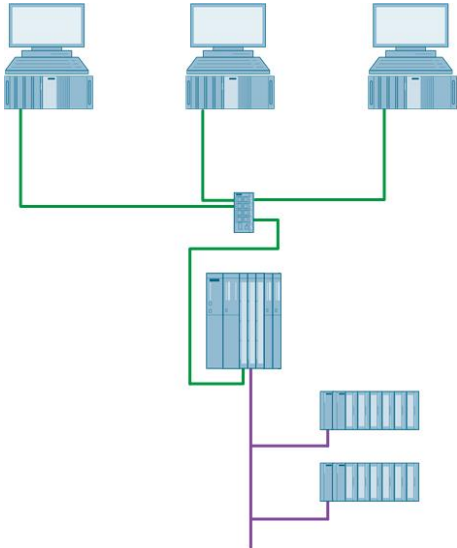

2.3 Multiple-user system

Table 2-3

Number of inputs/outputs:	
500 -1,000	
Number of operators:	
two to five	
	

2.4 Client/server system

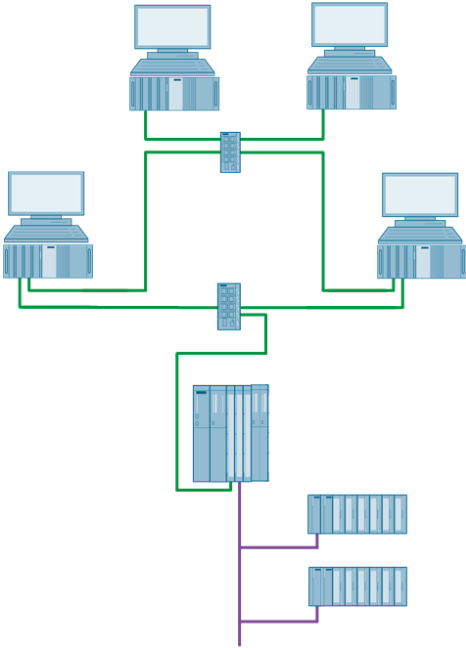
Table 2-4

Number of inputs/outputs:	
800 -2,000	
Number of operators:	
three to sixteen	
	

2.5 Client/Server System with several servers

Table 2-5

Number of inputs/outputs:	<p>The diagram illustrates a network architecture. At the top, there are six client workstations, each consisting of a monitor and a tower PC. These are connected to a central server rack. The server rack contains several server units. Below the server rack, there are two large server cabinets, each with a red vertical line indicating a power or cooling section. The network is connected to a central switch or hub, which is then connected to the server rack and the server cabinets. The connections are shown as green lines.</p>
1,500 -120,000	
Number of operators:	
twelve to thirty-two	



3 Entry-level systems

Entry-level systems

If one or two operators and less than 300 I/O must be supported, the SIMATIC PCS 7 BOX RTX system is a powerful and also cost-effective solution.

The PCS 7 BOX RTX has a software OS, based on the proven WinAC technology (Windows Automation Center). This software CPU runs with Ardence RTX® real-time operating system under Windows. It provides a high-performance control logic for the design and memory.

The PCS 7 BOX RTX is available in two versions:

1. Automation system (AS), Operator System (OS) and Engineering System (ES)
2. Automation system (AS) and Operator System (OS)

The PCS 7 BOX RTX can be equipped with a "2 Screen" Multi VGA graphics card, which enables the connection of two monitors to the system.

Separate Engineering System

Engineering can be carried out by a separate Engineering System. In this case, the SIMATIC PCS 7 BOX RTX consists of just the AS and OS. Thus, the Engineering System may be used as an Operator System.

SIMATIC PCS 7 BOX RTX as an OS client

When combined with a larger SIMATIC PCS 7 system, the SIMATIC PCS 7 BOX can be used as an OS client for the OS server. At the same time, the AS is connected with the OS server as part of the SIMATIC PCS 7 BOX RTX.

SIMATIC PCS 7 AS RTX system

SIMATIC PCS 7 provides a Microbox automation system with a software controller for less demanding applications. The Microbox system is based on the SIMATIC Microbox PC427C platform, on which the Windows XP Embedded operating system runs. When combined with the Windows real-time extension Ardence RTX® and the WinAC RTX software controller, this system offers a compact controller for applications at system level.

SIMATIC PCS 7 OS Client 427C (Microbox)

The SIMATIC Microbox PC is also available as an OS client in the version SIMATIC PCS 7 OS Client 427C and can be used as a client for the Operator System and SIMATIC Batch in SIMATIC PCS 7 systems.

Note

Fieldbus components, racks, modules and field devices are not listed in the following bill of materials.

3.1 Entry-level system

Figure 3-1

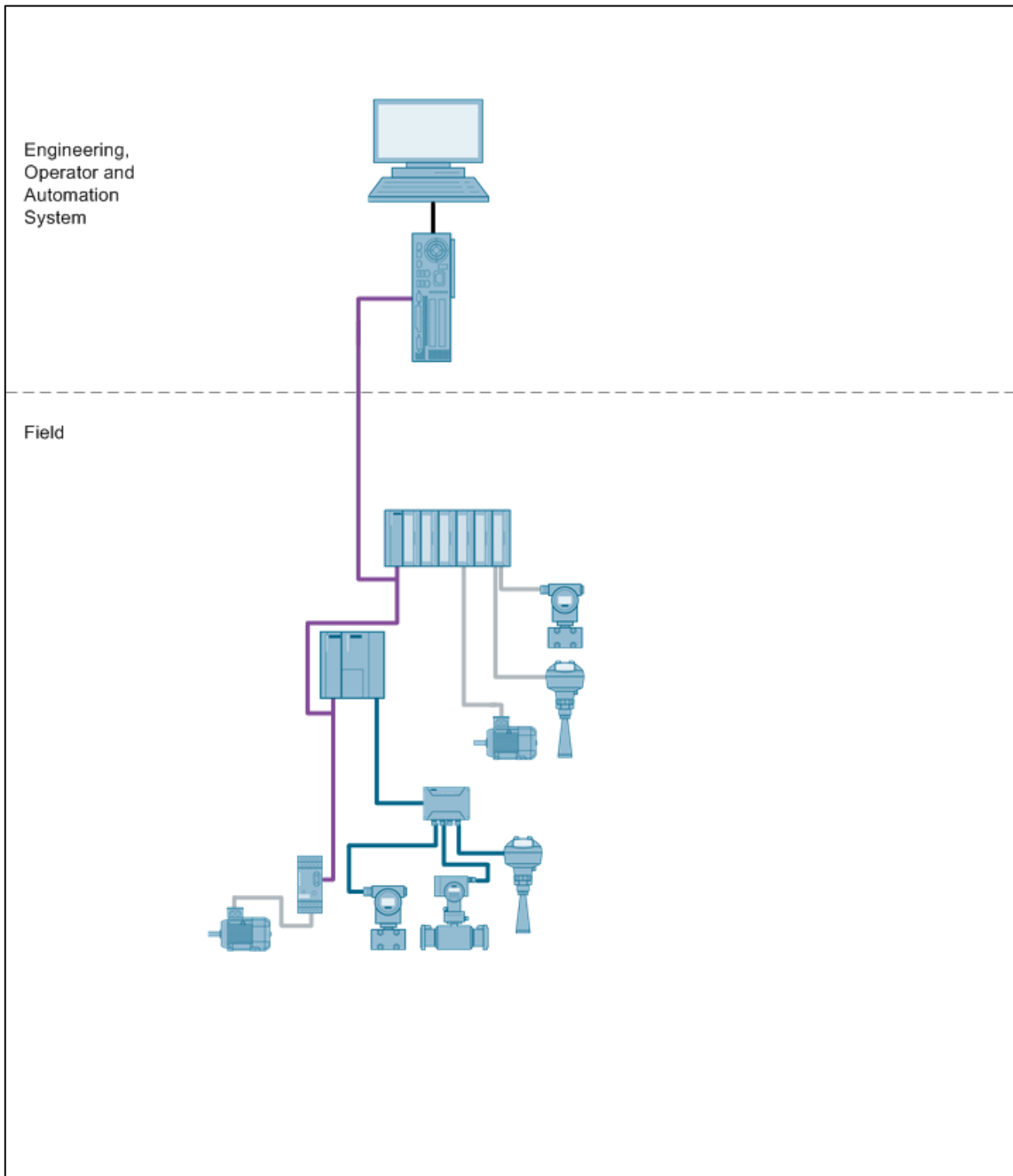

Bill of material for the PCS 7 BOX RTX based entry-level system

Table 3-1

Required	Optional	Product number	Product description	Note
Engineering, operator and automation system				
1		6ES7650-4AA11-0GA0	SIMATIC PCS 7 BOX RTX V8.0 SP1 ALL-IN-ONE SYSTEM (ES, OS AND AS)	1) 2)
	1	6ES7 652-0XD08-2YB5	SOFTWARE SIMATIC PCS 7 SFC VISUALIZATION V8.0	
	1	6ES7 658-1CX17-2YA5	SOFTWARE SIMATIC PCS 7 VERSION CROSS MANAGER V7.1	
	1	6ES7 658-1FX08-2YA5	SOFTWARE SIMATIC PCS 7 VERSION TRAIL V8.0	
	1	6ES7 658-1DX08-2YB5	SOFTWARE SIMATIC PCS 7 IMPORT EXPORT ASSISTANT V8.0	

Note

¹⁾ Please use the PCS 7 BOX configurator, as the PCS 7 BOX is available in different versions, e.g. 24V DC or 110/230V AC.

²⁾ The number of POs can be increased later on by means of extra volume licenses.

3.2 Separate ES in the entry-level system

Figure 3-2

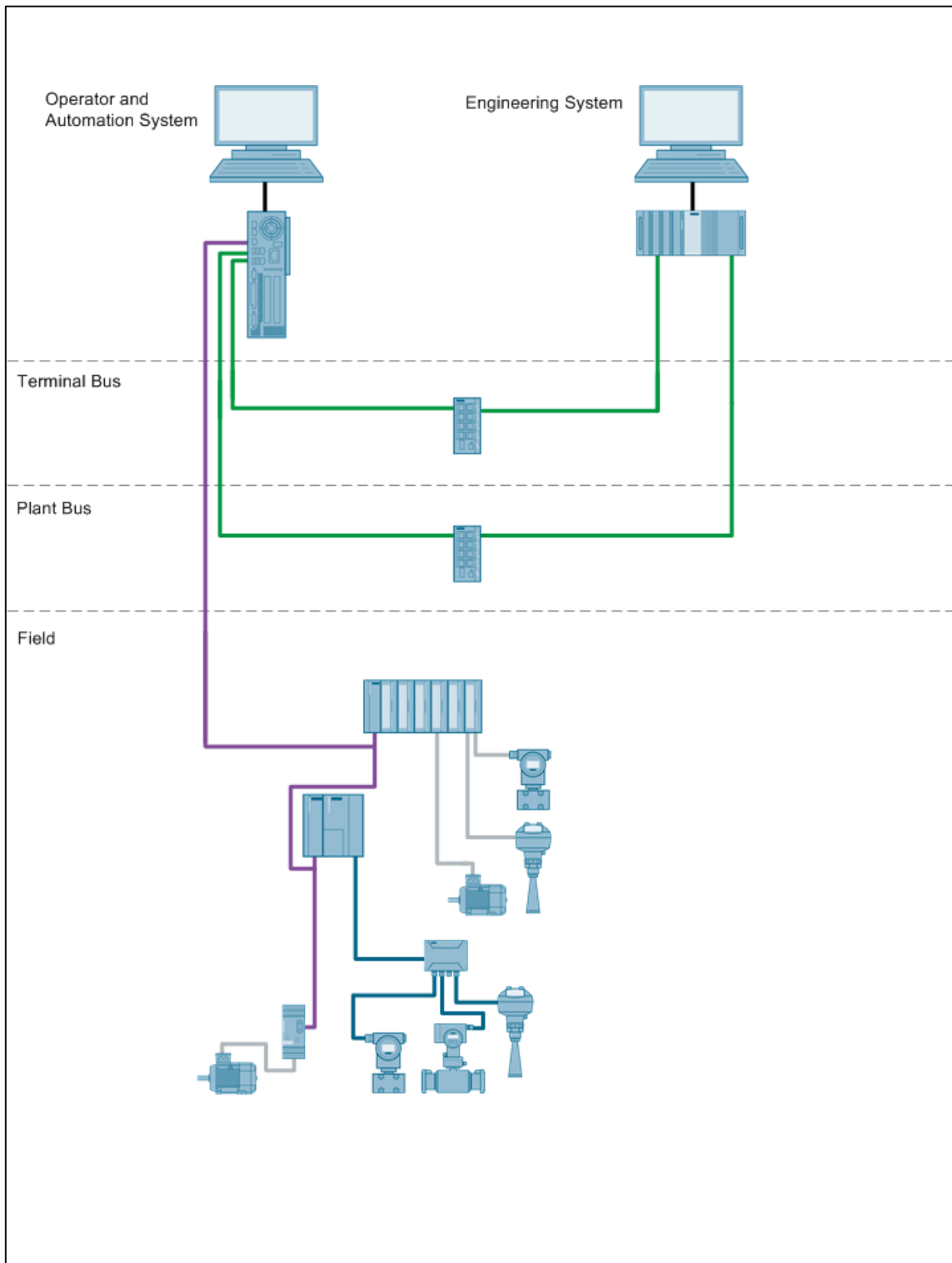

Bill of material for the PCS 7 BOX RTX based entry-level system with a separate Engineering System

Table 3–2

Required	Optional	Product number	Product description	Note
Operator and automation system				
1		6ES7650-4AA11-0HA0	SIMATIC PCS 7 BOX RTX V8.0 RUNTIME SYSTEM (OS AND AS)	1) 2)
	1	6ES7 652-0XD08-2YB5	SOFTWARE SIMATIC PCS 7 SFC VISUALIZATION V8.0	
Engineering System				
1		6ES7660-2AA30-1CA0	SIMATIC PCS 7 INDUSTRIAL WORKSTATION IPC547DIPC847C, CORE I7, ES/OS SINGLESTATION, RAID1 (500GB INTERNAL), 8GB DDR3, BCE, PCS 7 V8.0 SP1, WIN 7	3)
1		6ES7 658-5AX08-0YA5	SOFTWARE SIMATIC PCS 7 AS/OS ENGINEERING V8.0	
	1	6ES7 658-1CX17-2YA5	SOFTWARE SIMATIC PCS 7 VERSION CROSS MANAGER V7.1	
	1	6ES7 658-1FX08-2YA5	SOFTWARE SIMATIC PCS 7 VERSION TRAIL V8.0	
	1	6ES7 658-1DX08-2YB5	SOFTWARE SIMATIC PCS 7 IMPORT EXPORT ASSISTANT V8.0	
Terminal bus				
1		6GK5 208-0BA10-2AA3	SIMATIC NET SCALANCE X208, MANAGED IE SWITCH, 8 X 10/100MBIT/S	4)
2		6XV1 870-3QH60	SIMATIC NET INDUSTRIAL ETHERNET TP CORD CABLE RJ45/RJ45, 6M	
System bus				
1		6GK5 208-0BA10-2AA3	SIMATIC NET SCALANCE X208, MANAGED IE SWITCH, 8 X 10/100MBIT/S	4)
2		6XV1 870-3QH60	SIMATIC NET INDUSTRIAL ETHERNET TP CORD CABLE RJ45/RJ45, 6M	

Note

1) Please use the PCS 7 BOX configurator, as the PCS 7 BOX is available in different versions, e.g. 24V DC or 110/230V AC.

2) The number of POs can be increased later on by means of extra volume licenses.

3) The Engineering System is not intended for use as a secondary Operator System.

4) SCALANCE switch requires a 24VDC power supply (not listed).

3.3 Entry-level system with dual monitor

Figure 3-3

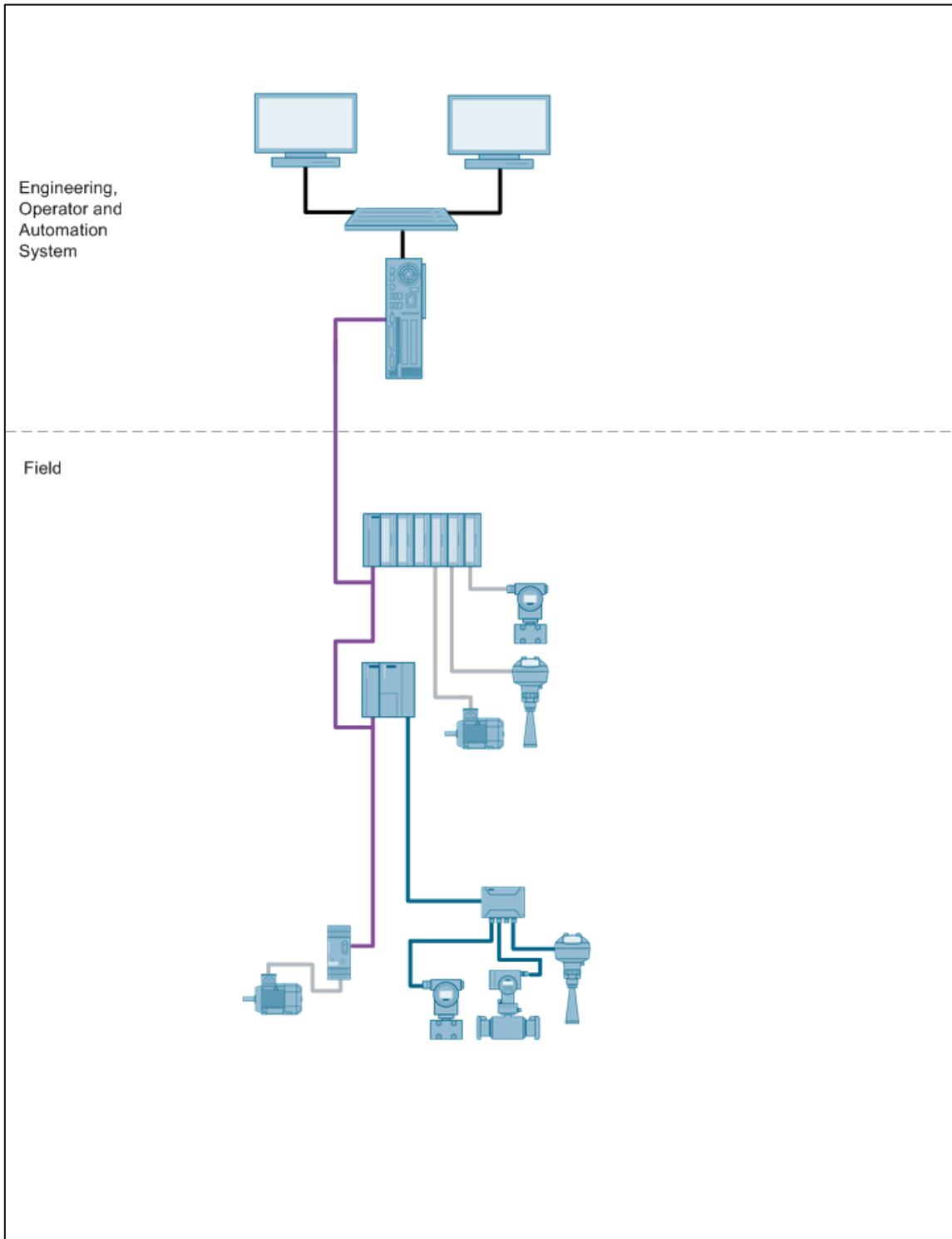

Bill of material for the PCS 7 BOX RTX based entry-level system with dual monitor

Table 3-3

Required	Optional	Product number	Product description	Note
Engineering, operator and automation system				
1		6ES7650-4AA11-0GA0	SIMATIC PCS 7 BOX RTX V8.0 SP1 ALL-IN-ONE SYSTEM (ES, OS AND AS)	1) 2)
1		6ES7 652-0XX04-1XE0	SIMATIC PCS 7 MULTI MONITOR VGA 2-SCREEN CARD	
	1	6ES7 652-0XD08-2YB5	SOFTWARE SIMATIC PCS 7 SFC VISUALIZATION V8.0	
	1	6ES7 658-1CX17-2YA5	SOFTWARE SIMATIC PCS 7 VERSION CROSS MANAGER V7.1	
	1	6ES7 658-1FX08-2YA5	SOFTWARE SIMATIC PCS 7 VERSION TRAIL V8.0	
	1	6ES7 658-1DX08-2YB5	SOFTWARE SIMATIC PCS 7 IMPORT EXPORT ASSISTANT V8.0	

Note

¹⁾ Please use the PCS 7 BOX configurator, as the PCS 7 BOX is available in different versions, e.g. 24V DC or 110/230V AC.

²⁾ The number of POs can be increased later on by means of extra volume licenses.

3.4 Entry-level SIMATIC PCS 7 BOX RTX as ES and OS Client

Figure 3-4

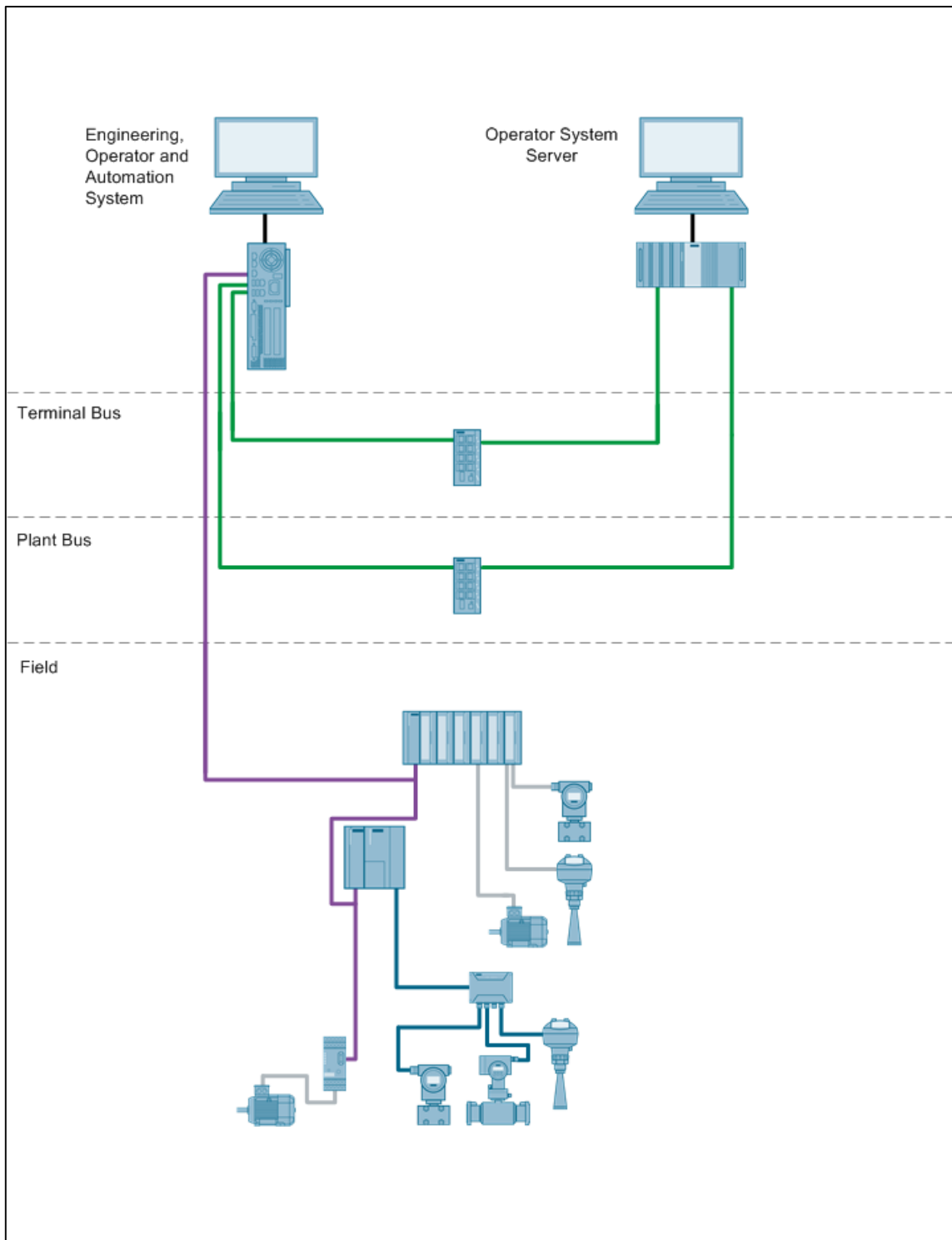

Copyright © Siemens AG 2013 All rights reserved

Bill of material for the entry-level system with PCS 7 BOX RTX as an OS client

Table 3-4

Required	Optional	Product number	Product description	Note
Engineering, operator and automation system				
1		6ES7 650-4AA11-0GA0	SIMATIC PCS 7 BOX RTX V8.0 SP1 ALL-IN-ONE SYSTEM (ES, OS AND AS)	1) 2)
	1	6ES7 652-0XD08-2YB5	SOFTWARE SIMATIC PCS 7 SFC VISUALIZATION V8.0	
	1	6ES7 658-1CX17-2YA5	SOFTWARE SIMATIC PCS 7 VERSION CROSS MANAGER V7.1	
	1	6ES7 658-1FX08-2YA5	SOFTWARE SIMATIC PCS 7 VERSION TRAIL V8.0	
	1	6ES7 658-1DX08-2YB5	SOFTWARE SIMATIC PCS 7 IMPORT EXPORT ASSISTANT V8.0	
Operator System server				
1		6ES7660-2BA30-1DA0	SIMATIC PCS 7 INDUSTRIAL WORKSTATION IPC847C, CORE I7, OS SERVER, RAID1 (500GB INTERNAL), 8GB DDR3, BCE, PCS 7 V8.0 SP1, WIN SERVER 2008	
1		6ES7 658-2BA08-0YA0	SOFTWARE SIMATIC PCS 7 OS SOFTWARE SERVER V8.0 (PO 100)	2)
	1	6ES7 652-0XD08-2YB5	SOFTWARE SIMATIC PCS 7 SFC VISUALIZATION V8.0	
Terminal bus				
1		6GK5 208-0BA10-2AA3	SIMATIC NET SCALANCE X208, MANAGED IE SWITCH, 8 X 10/100MBIT/S	3)
2		6XV1 870-3QH60	SIMATIC NET INDUSTRIAL ETHERNET TP CORD CABLE RJ45/RJ45, 6M	
System bus				
1		6GK5 208-0BA10-2AA3	SIMATIC NET SCALANCE X208, MANAGED IE SWITCH, 8 X 10/100MBIT/S	3)
2		6XV1 870-3QH60	SIMATIC NET INDUSTRIAL ETHERNET TP CORD CABLE RJ45/RJ45, 6M	

Note

¹⁾ Please use the PCS 7 BOX configurator, as the PCS 7 BOX is available in different versions, e.g. 24V DC or 110/230V AC.

²⁾ The number of POs can be increased later on by means of extra volume licenses.

³⁾ SCALANCE switch requires a 24VDC power supply (not listed).

3.5 SIMATIC PCS 7 AS RTX system

Figure 3-5

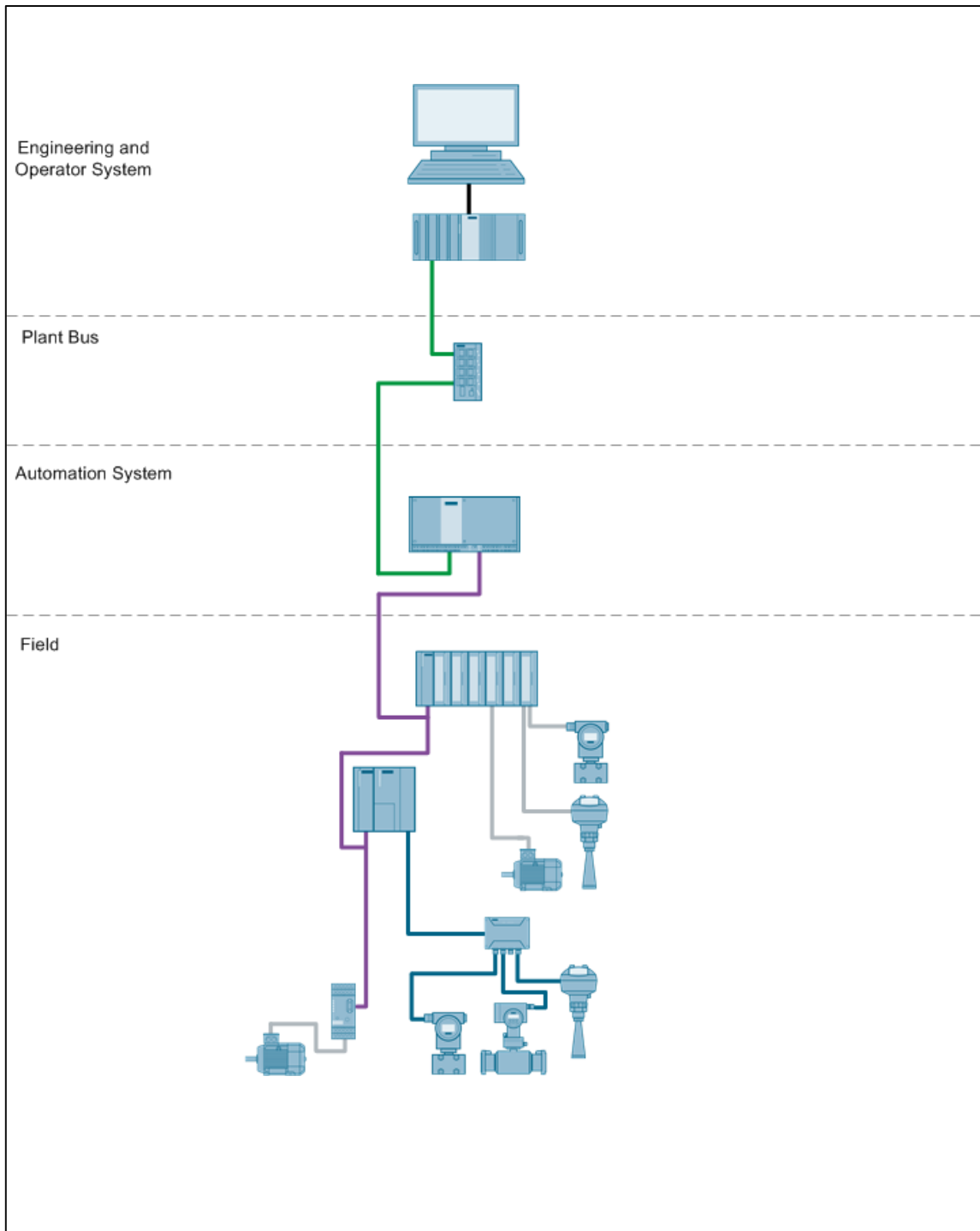

Copyright © Siemens AG 2013 All rights reserved

Bill of material for the SIMATIC PCS 7 AS RTX system

Table 3-5

Required	Optional	Product number	Product description	Note
Automation system				
1		6ES7 654-0UE13-0XX0	SIMATIC PCS 7 AS RTX AUTOMATION SYSTEM BASED ON IPC427C, AS RT PO 100	1) 3)
Engineering System and Operator System				
1		6ES7660-2AA30-1CA0	SIMATIC PCS 7 INDUSTRIAL WORKSTATION IPC547DIPC847C, CORE I7, ES/OS SINGLESTATION, RAID1 (500GB INTERNAL), 8GB DDR3, BCE, PCS 7 V8.0 SP1, WIN 7	
1		6ES7 658-5AX08-0YA5	SOFTWARE SIMATIC PCS 7 AS/OS ENGINEERING V8.0	
1		6ES7 658-2AA08-0YA0	SOFTWARE SIMATIC PCS 7 OS SOFTWARE SINGLE STATION V8.0 (PO 100)	1)
	1	6ES7 652-0XD08-2YB5	SOFTWARE SIMATIC PCS 7 SFC VISUALIZATION V8.0	
	1	6ES7 658-1CX17-2YA5	SOFTWARE SIMATIC PCS 7 VERSION CROSS MANAGER V7.1	
	1	6ES7 658-1FX08-2YA5	SOFTWARE SIMATIC PCS 7 VERSION TRAIL V8.0	
	1	6ES7 658-1DX08-2YB5	SOFTWARE SIMATIC PCS 7 IMPORT EXPORT ASSISTANT V8.0	
System bus				
1		6GK5 208-0BA10-2AA3	SIMATIC NET SCALANCE X208, MANAGED IE SWITCH, 8 X 10/100MBIT/S	2)
2		6XV1 870-3QH60	SIMATIC NET INDUSTRIAL ETHERNET TP CORD CABLE RJ45/RJ45, 6M	

Note

- 1) The number of POs can be increased later on by means of extra volume licenses.
- 2) SCALANCE switch requires a 24VDC power supply (not listed)
- 3) PCS 7 AS RTX controller needs to be supplied with 24 VDC (not listed)

4 Single-user system

Single-user system

For small process control systems, where engineering or operation tasks are carried out by only one user, the single-user architecture of PCS 7 offers a cost-effective solution. In this architecture, the functionality of the Engineering System (ES) and the Operator System (OS) is integrated into one PC.

Dual-Monitor

A single station or an Engineering System can be expanded with a "2 screen" or "4 screen" Multi VGA graphics card, which enables connection of up to four monitors per system.

4.1 Single-user system

Figure 4-1

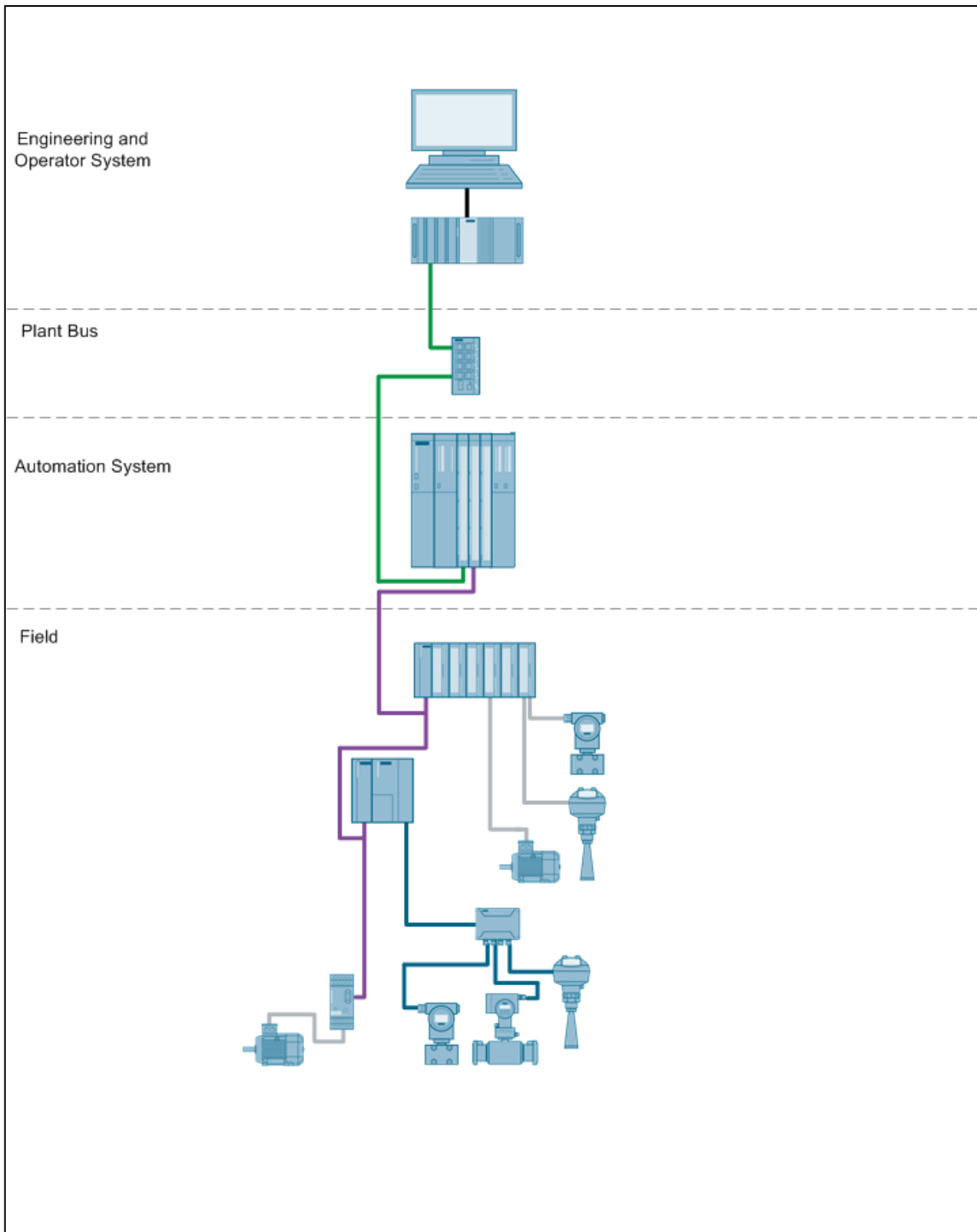

Bill of material for the single-user system

Table 4–1

Required	Optional	Product number	Product description	Note
Engineering and Operator System				
1		6ES7660-2AA30-1CA0	SIMATIC PCS 7 INDUSTRIAL WORKSTATION IPC547DIPC847C, CORE I7, ES/OS SINGLESTATION, RAID1 (500GB INTERNAL), 8GB DDR3, BCE, PCS 7 V8.0 SP1, WIN 7	
1		6ES7 658-5AX08-0YA5	SOFTWARE SIMATIC PCS 7 AS/OS ENGINEERING V8.0	
1		6ES7 658-2AA08-0YA0	SOFTWARE SIMATIC PCS 7 OS SOFTWARE SINGLE STATION V8.0 (PO 100)	1)
	1	6ES7 652-0XD08-2YB5	SOFTWARE SIMATIC PCS 7 SFC VISUALIZATION V8.0	
	1	6ES7 658-1CX17-2YA5	SOFTWARE SIMATIC PCS 7 VERSION CROSS MANAGER V7.1	
	1	6ES7 658-1FX08-2YA5	SOFTWARE SIMATIC PCS 7 VERSION TRAIL V8.0	
	1	6ES7 658-1DX08-2YB5	SOFTWARE SIMATIC PCS 7 IMPORT EXPORT ASSISTANT V8.0	
System bus				
1		6GK5 208-0BA10-2AA3	SIMATIC NET SCALANCE X208, MANAGED IE SWITCH, 8 X 10/100MBIT/S	2)
2		6XV1 870-3QH60	SIMATIC NET INDUSTRIAL ETHERNET TP CORD CABLE RJ45/RJ45, 6M	
Automation system				
1		6ES7 654-6CL03-3BF0	SIMATIC PCS 7 SINGLE AS, CPU 410-5H, 1X DP-MODULE, 1x PROFINET-IO, SYSTEM EXPANSIONS CARD 500 PO, AS RT PO 100, CP443-1IE, UR2 ALU RACK, 1 X UC 120/230V 10A POWER SUPPLY	1) 3)

Note

¹⁾ The number of POs can be increased later on by means of extra volume licenses.

²⁾ SCALANCE switch requires a 24VDC power supply (not listed).

³⁾ Please use the PCS 7 AS configurator, as the PCS 7 AS 410-5H is available in different versions, e.g. 24V DC or 110/230V AC.

4.2 Single-user station with dual monitor

Figure 4-2

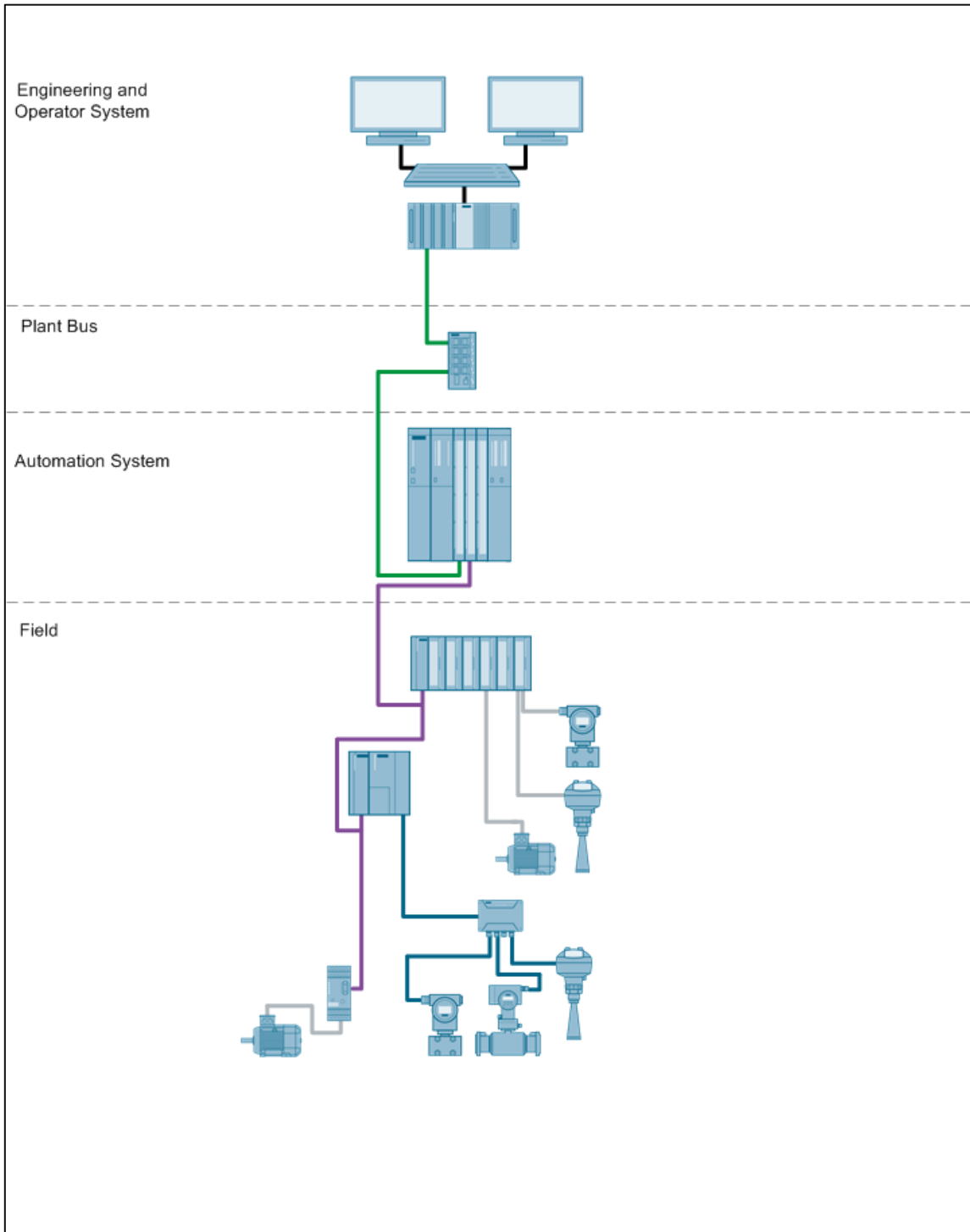

Bill of material for the single-user system with dual monitor

Table 4–2

Required	Optional	Product number	Product description	Note
Engineering and Operator System				
1		6ES7660-2AA50-1CB0	SIMATIC PCS 7 INDUSTRIAL WORKSTATION IPC847C, CORE I7, ES/OS SINGLESTATION, RAID1 (500GB INTERNAL), 8GB DDR3, BCE, MULTI VGA 2-SCREEN CARD PCS 7 V8.0 SP1, WIN 7	¹⁾
1		6ES7 658-5AX08-0YA5	SOFTWARE SIMATIC PCS 7 AS/OS ENGINEERING V8.0	
1		6ES7 658-2AA08-0YA0	SOFTWARE SIMATIC PCS 7 OS SOFTWARE SINGLE STATION V8.0 (PO 100)	²⁾
	1	6ES7 652-0XD08-2YB5	SOFTWARE SIMATIC PCS 7 SFC VISUALIZATION V8.0	
	1	6ES7 658-1CX17-2YA5	SOFTWARE SIMATIC PCS 7 VERSION CROSS MANAGER V7.1	
	1	6ES7 658-1FX08-2YA5	SOFTWARE SIMATIC PCS 7 VERSION TRAIL V8.0	
	1	6ES7 658-1DX08-2YB5	SOFTWARE SIMATIC PCS 7 IMPORT EXPORT ASSISTANT V8.0	
System bus				
1		6GK5 208-0BA10-2AA3	SIMATIC NET SCALANCE X208, MANAGED IE SWITCH, 8 X 10/100MBIT/S	³⁾
2		6XV1 870-3QH60	SIMATIC NET INDUSTRIAL ETHERNET TP CORD CABLE RJ45/RJ45, 6M	
Automation system				
1		6ES7 654-6CL03-3BF0	SIMATIC PCS 7 SINGLE AS, CPU 410-5H, 1X DP-MODULE, 1x PROFINET-IO, SYSTEM EXPANSIONS CARD 500 PO, AS RT PO 100, CP443-1IE, UR2 ALU RACK, 1 X UC 120/230V 10A POWER SUPPLY	²⁾ ⁴⁾

Note

- ¹⁾ If quad Multi VGA is available, the number of monitors must be increased accordingly.
- ²⁾ The number of POs can be increased later on by means of extra volume licenses.
- ³⁾ SCALANCE switch requires a 24VDC power supply (not listed).
- ⁴⁾ Please use the PCS 7 AS configurator, as the PCS 7 AS 410-5H is available in different versions, e.g. 24V DC or 110/230V AC.

4.3 Single-user station with web server

Figure 4-3

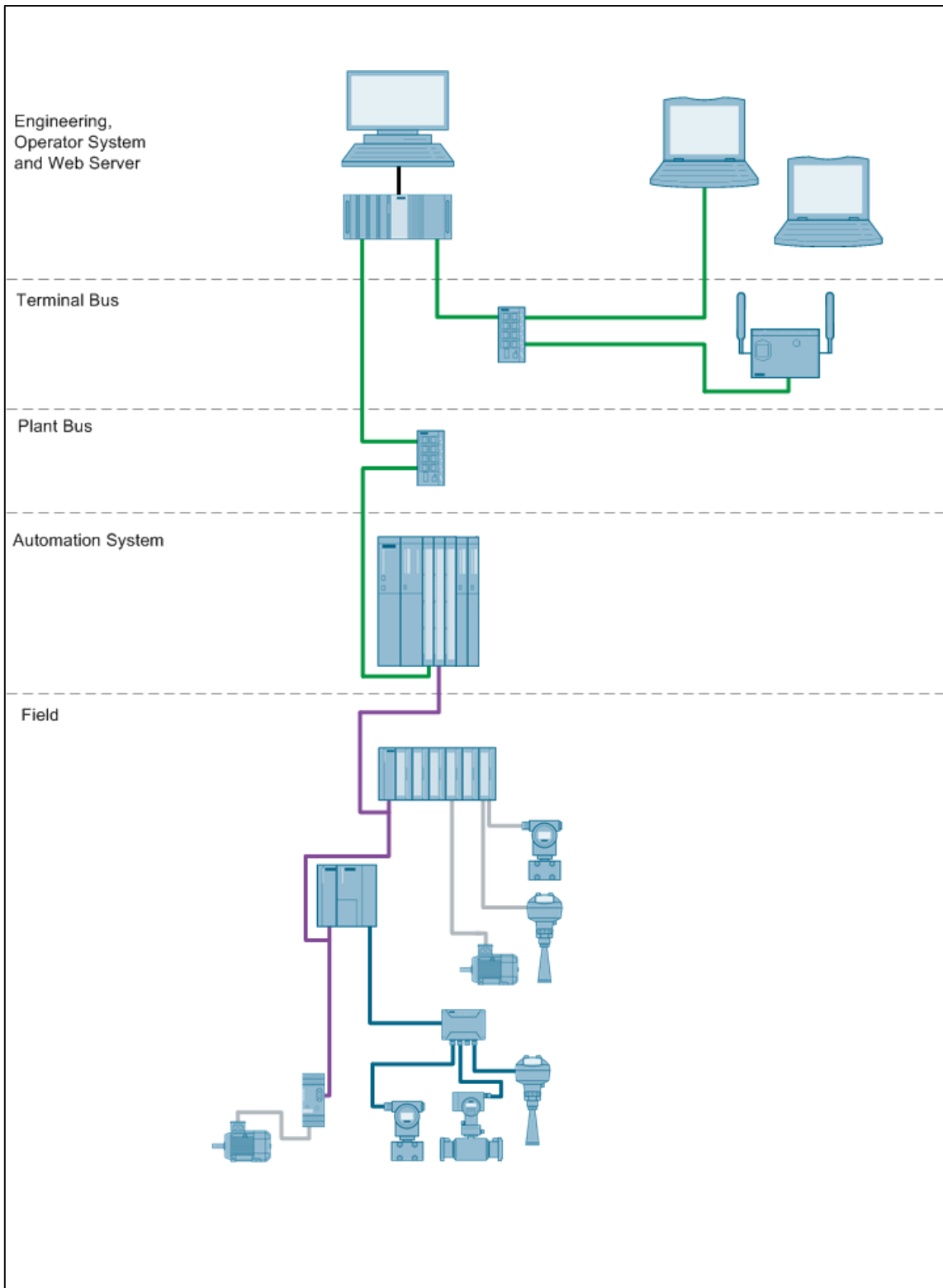

Copyright © Siemens AG 2013 All rights reserved

Bill of material for the single-user system with web server

Table 4–3

Required	Optional	Product number	Product description	Note
Engineering and Operator System				
1		6ES7660-2BA30-1DA0	SIMATIC PCS 7 INDUSTRIAL WORKSTATION IPC847D, CORE I7, OS SERVER, RAID1 (500GB INTERNAL), 8GB DDR3, BCE, PCS 7 V8.0 SP1, WIN SERVER 2008	
1		6ES7 658-5AX08-0YA5	SOFTWARE SIMATIC PCS 7 AS/OS ENGINEERING V8.0	
1		6ES7 658-2AA08-0YA0	SOFTWARE SIMATIC PCS 7 OS SOFTWARE SINGLE STATION V8.0 (PO 100)	1)
1		6ES7658-2HX08-2YB0	SOFTWARE SIMATIC PCS 7 WEB DIAGNOSE SERVER V8.0	5)
	1	6ES7 652-0XD08-2YB5	SOFTWARE SIMATIC PCS 7 SFC VISUALIZATION V8.0	
	1	6ES7 658-1CX17-2YA5	SOFTWARE SIMATIC PCS 7 VERSION CROSS MANAGER V7.1	
	1	6ES7 658-1FX08-2YA5	SOFTWARE SIMATIC PCS 7 VERSION TRAIL V8.0	
	1	6ES7 658-1DX08-2YB5	SOFTWARE SIMATIC PCS 7 IMPORT EXPORT ASSISTANT V8.0	
Terminal bus				
1		6GK5 208-0BA10-2AA3	SIMATIC NET SCALANCE X208, MANAGED IE SWITCH, 8 X 10/100MBIT/S	4)
2		6XV1 870-3QH60	SIMATIC NET INDUSTRIAL ETHERNET TP CORD CABLE RJ45/RJ45, 6M	
System bus				
1		6GK5 208-0BA10-2AA3	SIMATIC NET SCALANCE X208, MANAGED IE SWITCH, 8 X 10/100MBIT/S	2)
2		6XV1 870-3QH60	SIMATIC NET INDUSTRIAL ETHERNET TP CORD CABLE RJ45/RJ45, 6M	
Wireless LAN				
1		6GK5 788-1AA60-2AB0	IWLAN ACCESS POINT SCALANCE W788-1PRO	2) 4)
1		6GK1 907-0DC10-6AA3	POWER M12 CABLE CONNECTOR PRO	6)
1		6XV1 870-3QH60	SIMATIC NET INDUSTRIAL ETHERNET TP CORD CABLE RJ45/RJ45, 6M	

4 Single-user system

Required	Optional	Product number	Product description	Note
Automation system				
1		6ES7654-6CL03-3BF0	SIMATIC PCS 7 SINGLE AS, CPU 410-5H, 1X DP-MODULE, 1x PROFINET-IO, SYSTEM EXPANSIONS CARD 500 PO, AS RT PO 100, CP443-1IE, UR2 ALU RACK, 1 X UC 120/230V 10A POWER SUPPLY	1) 3)
Web client system				
2		6ES7658-2JX08-2YB0	SOFTWARE SIMATIC PCS 7 WEB DIAGNOSE CLIENT V8.0	5)

Note

The laptop (web clients) hardware is not listed.

¹⁾ The number of POs can be increased later on by means of extra volume licenses.

²⁾ SCALANCE switch requires a 24VDC power supply (not listed).

³⁾ Please use the PCS 7 AS configurator, as the PCS 7 AS 410-5H is available in different versions, e.g. 24V DC or 110/230V AC. ⁴⁾ Wireless LAN access point with approval for USA and Canada, approval for other countries requires a different version of W788-1PRO.

⁵⁾ Alternative to the Diagnostic licenses for servers and clients, server-based licensing can be selected for up to 3 web clients.

⁶⁾ The selected cable is based on the architecture in which Access Point W88-1PRO is powered by a separate 24 VDC current source.

5 System with multiple OS single stations

System with multiple OS single stations

Two to five users and typically up to 1000 inputs and outputs can be supported and controlled with one SIMATIC PCS 7 System, composed of several single stations.

In such an architecture, the system can consist of up to 8 single stations. The single stations are configured and loaded from an Engineering System (ES) in a single OS project. Since the entire database is copied to all single stations, the entire plant can be controlled from a single location. It can be archived simultaneously on all single stations. However, there is no synchronization between the single locations, and archives for alarms and tags run independent from each other.

Redundancy

Two OS single stations can be optionally equipped with redundancy software and hardware components to create a high availability Operator System. In this case, the archive synchronization occurs between the redundant single stations. Terminal bus, system bus, automation system/s (AS) and fieldbus can also be set as redundant. This redundancy option for the OS is limited to two OS single stations.

Quantity structures

OS single station configurations are only intended for small and medium-sized plants in the lower area. If more than two OS single stations are to be deployed, a client/server architecture is generally more economical.

In contrast to OS servers, OS single stations have the following restrictions:

- Released number: 8 OS single stations
- Max. number of process objects per OS single station: 5,000 POs
- Number of measuring points per OS single station: around 3,000

Dual-Monitor

Every OS or ES can be equipped with a "2 screen" or "4 screen" Multi VGA graphics card, which enables connection of up to four monitors per system.

Note

For more than one redundant pair of OSs, there is neither the availability of the archive synchronization nor a redundancy for alarms and process variables under each other.

When connected with SIMATIC BATCH, there is a restriction that allows BATCH to be only used on one of the OS single stations. A separate project must be created for such OS single station.

5.1 Multiple OS single stations

Figure 5-1

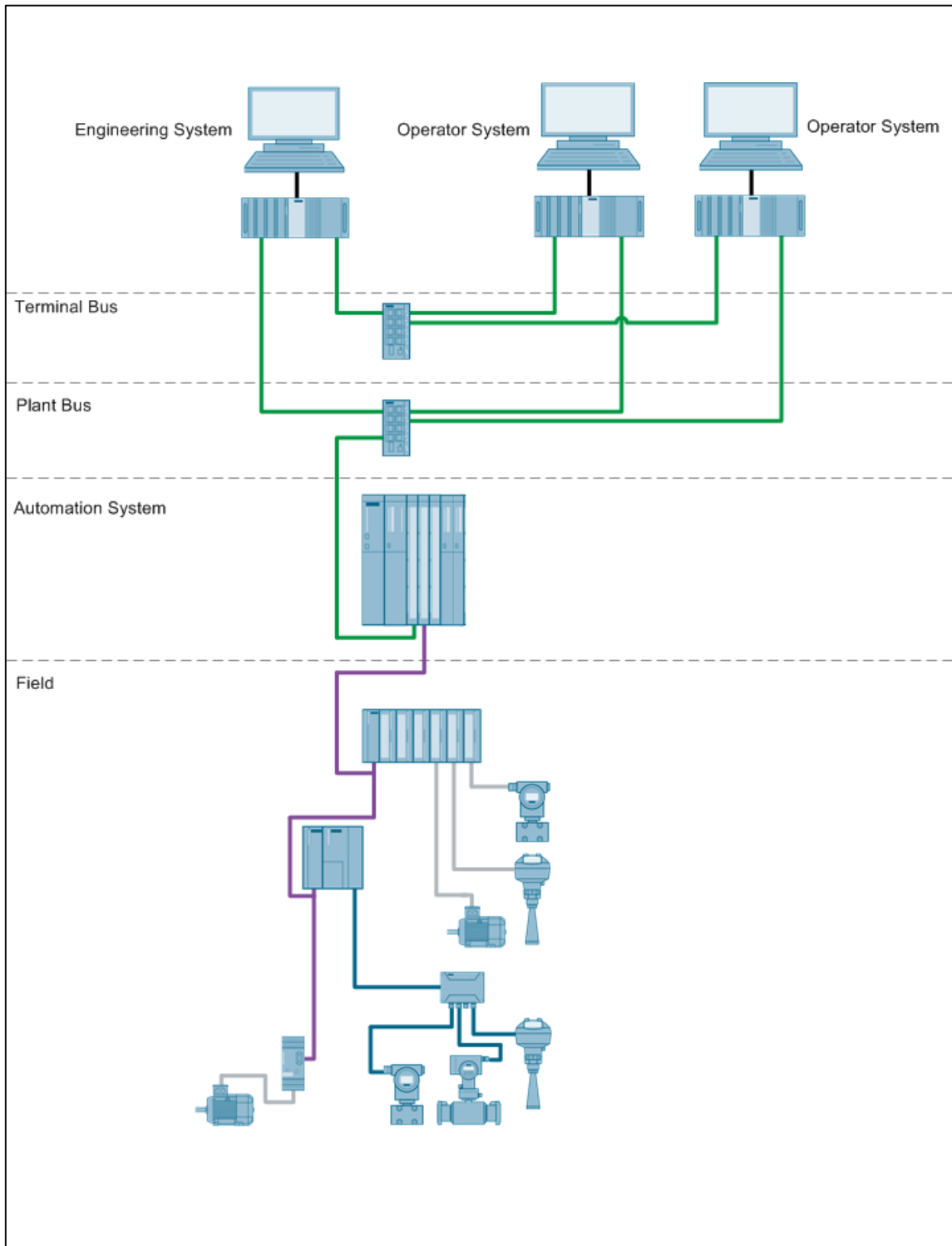

Bill of material for multiple OS single stations

Table 5-1

Required	Optional	Product number	Product description	Note
Engineering System				
1		6ES7660-2AA30-1CA0	SIMATIC PCS 7 INDUSTRIAL WORKSTATION IPC547DIPC847C, CORE I7, ES/OS SINGLESTATION, RAID1 (500GB INTERNAL), 8GB DDR3, BCE, PCS 7 V8.0 SP1, WIN 7	
1		6ES7 658-5AX08-0YA5	SOFTWARE SIMATIC PCS 7 AS/OS ENGINEERING V8.0	
	1	6ES7 658-1CX17-2YA5	SOFTWARE SIMATIC PCS 7 VERSION CROSS MANAGER V7.1	
	1	6ES7 658-1FX08-2YA5	SOFTWARE SIMATIC PCS 7 VERSION TRAIL V8.0	
	1	6ES7 658-1DX08-2YB5	SOFTWARE SIMATIC PCS 7 IMPORT EXPORT ASSISTANT V8.0	
Human machine interface				
2		6ES7660-2AA30-1CA0	SIMATIC PCS 7 INDUSTRIAL WORKSTATION IPC547DIPC847C, CORE I7, ES/OS SINGLESTATION, RAID1 (500GB INTERNAL), 8GB DDR3, BCE, PCS 7 V8.0 SP1, WIN 7	
2		6ES7 658-2AA08-0YA0	SOFTWARE SIMATIC PCS 7 OS SOFTWARE SINGLE STATION V8.0 (PO 100)	¹⁾
	2	6ES7 652-0XD08-2YB5	SOFTWARE SIMATIC PCS 7 SFC VISUALIZATION V8.0	

5 System with multiple OS single stations

Required	Optional	Product number	Product description	Note
Terminal bus				
1		6GK5 208-0BA10-2AA3	SIMATIC NET SCALANCE X208, MANAGED IE SWITCH, 8 X 10/100MBIT/S	²⁾
3		6XV1 870-3QH60	SIMATIC NET INDUSTRIAL ETHERNET TP CORD CABLE RJ45/RJ45, 6M	
System bus				
1		6GK5 208-0BA10-2AA3	SIMATIC NET SCALANCE X208, MANAGED IE SWITCH, 8 X 10/100MBIT/S	²⁾
4		6XV1 870-3QH60	SIMATIC NET INDUSTRIAL ETHERNET TP CORD CABLE RJ45/RJ45, 6M	
Automation system				
1		6ES7654-6CN03-3BF0	SIMATIC PCS 7 SINGLE AS, CPU 410-5H, 1X DP-MODULE, 1x PROFINET-IO, SYSTEM EXPANSIONS CARD 1000 PO, AS RT PO 100, CP443-1IE, UR2 ALU RACK, 1 X UC 120/230V 10A POWER SUPPLY	³⁾

Note

- ¹⁾ The number of POs can be increased later on by means of extra volume licenses.
- ²⁾ SCALANCE switch requires a 24VDC power supply (not listed).
- ³⁾ Please use the PCS 7 AS configurator, as the PCS 7 AS 410-5H is available in different versions, e.g. 24V DC or 110/230V AC.

5.2 Redundant OS single stations

Figure 5-2

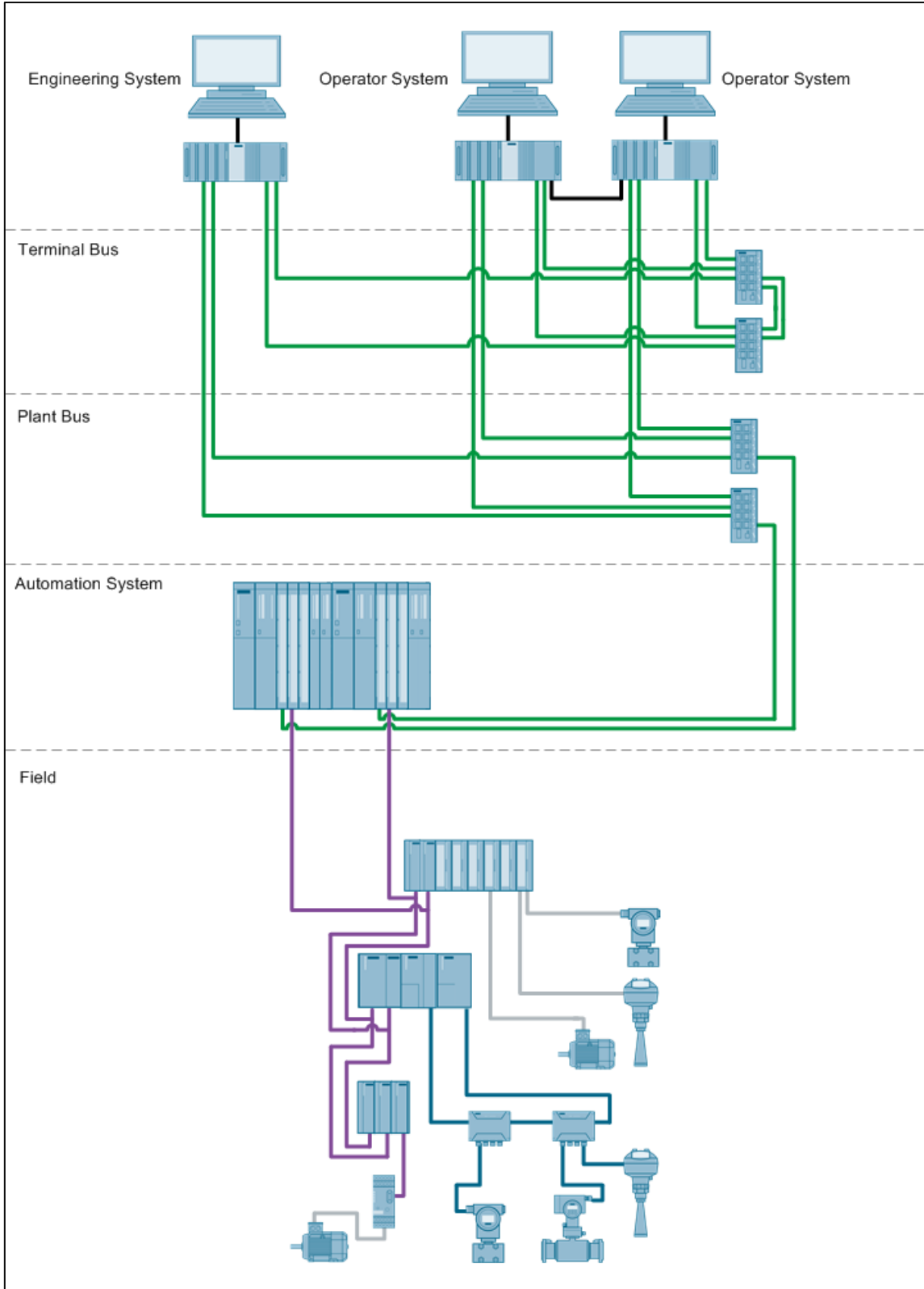

Bill of material for redundant OS single stations

Table 5–2

Required	Optional	Product number	Product description	Note
Engineering System				
1		6ES7660-2AA31-1CA0	SIMATIC PCS 7 INDUSTRIAL WORKSTATION IPC847C, CORE I7, ES/OS SINGLESTATION, RAID1 (500GB INTERNAL), 8GB DDR3, INDUSTRIAL ETHERNET (CP1623), PCS 7 V8.0 SP1, WIN 7	
1		6GK1 162-3AA00	SIMATIC NET COMMUNICATION PROCESSOR CP 1623 PCI EXPRESS	1)
1		6ES7 652-0XX01-1XF1	SIMATIC PCS 7 REDUNDANT TERMINAL BUS ADAPTER PACKAGE, 2 X INTEL PCI-E (EXPRESS) NETWORK CARD	2)
1		6ES7 658-5AX08-0YA5	SOFTWARE SIMATIC PCS 7 AS/OS ENGINEERING V8.0	
1		6GK1 716-0HB08-1AC0	SIMATIC NET, S7-REDCONNECT POWERPACK	4)
	1	6ES7 658-1CX17-2YA5	SOFTWARE SIMATIC PCS 7 VERSION CROSS MANAGER V7.1	
	1	6ES7 658-1FX08-2YA5	SOFTWARE SIMATIC PCS 7 VERSION TRAIL V8.0	
	1	6ES7 658-1DX08-2YB5	SOFTWARE SIMATIC PCS 7 IMPORT EXPORT ASSISTANT V8.0	
Operator System				
2		6ES7660-2AA31-1CA0	SIMATIC PCS 7 INDUSTRIAL WORKSTATION IPC847C, CORE I7, ES/OS SINGLESTATION, RAID1 (500GB INTERNAL), 8GB DDR3, INDUSTRIAL ETHERNET (CP1623), PCS 7 V8.0 SP1, WIN 7	
2			LCD MONITOR, 19"	
2		6ES7 648-0CB00-0YA0	SIMATIC PC KEYBOARD GERMAN / INTERNATIONAL USB INTERFACE	
2		6GK1 162-3AA00	SIMATIC NET COMMUNICATION PROCESSOR CP 1623 PCI EXPRESS	1)
1		6ES7 652-0XX01-1XF1	SIMATIC PCS 7 REDUNDANT TERMINAL BUS ADAPTER PACKAGE, 2 X INTEL PCI-E (EXPRESS) NETWORK CARD	2)
1		6ES7652-3AA08-2YA0	SOFTWARE SIMATIC PCS 7 OS SINGLE STATION REDUNDANCY V8.0 (PO 100)	3) 7)
2		6GK1 716-0HB08-1AC0	SIMATIC NET, S7-REDCONNECT POWERPACK	4)
	2	6ES7 652-0XD08-2YB5	SOFTWARE SIMATIC PCS 7 SFC VISUALIZATION V8.0	

5 System with multiple OS single stations

Required	Optional	Product number	Product description	Note
Terminal bus				
2		6GK5 208-0BA10-2AA3	SIMATIC NET SCALANCE X208, MANAGED IE SWITCH, 8 X 10/100MBIT/S	⁵⁾
6		6XV1 870-3QH60	SIMATIC NET INDUSTRIAL ETHERNET TP CORD CABLE RJ45/RJ45, 6M	
System bus				
2		6GK5 208-0BA10-2AA3	SIMATIC NET SCALANCE X208, MANAGED IE SWITCH, 8 X 10/100MBIT/S	⁵⁾
8		6XV1 870-3QH60	SIMATIC NET INDUSTRIAL ETHERNET TP CORD CABLE RJ45/RJ45, 6M	
Automation system				
1		6ES7656-6CL33-1CF0	SIMATIC PCS 7 REDUNDANCY AS, 2X CPU 410-5H, 2 DP-MODULE, 2X PROFINET-IO, SYSTEM EXPANSION CARD 500 PO, AS RT PO 100, 2 X 2 10M SYNC-MODULE AND 2 X 1M FO, 2 X CP443-1 IE/PN, 1 X UR2-H ALU RACK, 2 X UC 120/230V 10A RED. POWER SUPPLY	⁶⁾

Note

- ¹⁾ Required in case a redundant system bus is selected.
- ²⁾ Required in case a redundant terminal bus is selected.
- ³⁾ The number of POs can be increased later on by means of extra volume licenses.
- ⁴⁾ Required in case a redundant system bus or a redundant automation system is selected.
- ⁵⁾ SCALANCE switch requires a 24VDC power supply (not listed).
- ⁶⁾ Please use the PCS 7 AS configurator, as the PCS 7 AS 410-5H is available in different versions, e.g. 24V DC or 110/230V AC.
- ⁷⁾ The redundant OS single station is supplied with an RS-232 serial connection cable. If there is a long distance between the redundant systems, one can use an Ethernet connection as an alternative. This requires additional Ethernet network interface cards in the PCs.

5.3 Multiple OS single stations with dual monitor

Figure 5-3

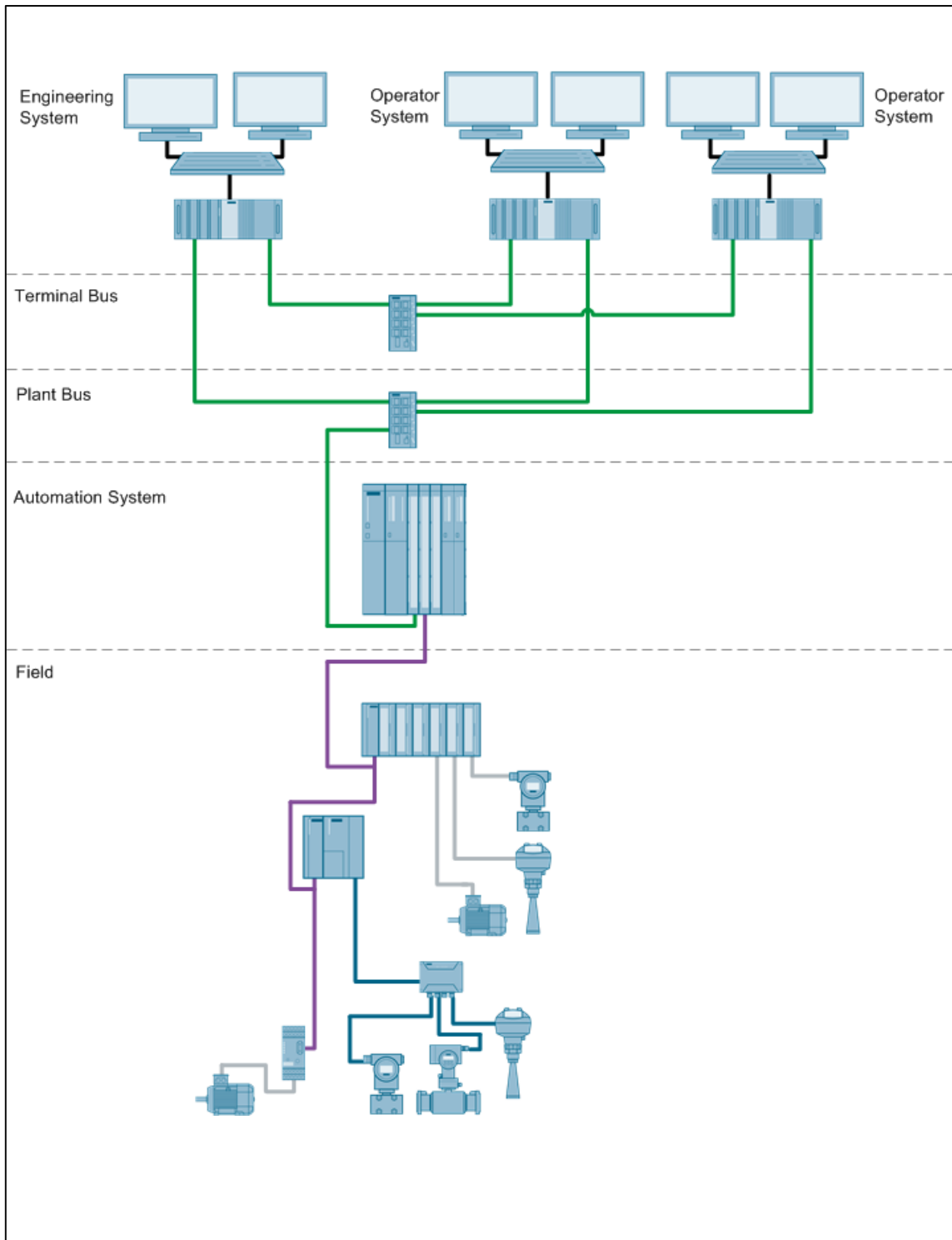

Copyright © Siemens AG 2013 All rights reserved

Bill of material for multiple OS single stations with dual monitor

Table 5–3

Required	Optional	Product number	Product description	Note
Engineering System and Operator System				
1		6ES7660-2AA50-1CB0	SIMATIC PCS 7 INDUSTRIAL WORKSTATION IPC847C, CORE I7, ES/OS SINGLESTATION, RAID1 (500GB INTERNAL), 8GB DDR3, BCE, MULTI VGA 2-SCREEN CARD PCS 7 V8.0 SP1, WIN 7	¹⁾
1		6ES7 658-5AX08-0YA5	SOFTWARE SIMATIC PCS 7 AS/OS ENGINEERING V8.0	
	1	6ES7 652-0XD08-2YB5	SOFTWARE SIMATIC PCS 7 SFC VISUALIZATION V8.0	
	1	6ES7 658-1CX17-2YA5	SOFTWARE SIMATIC PCS 7 VERSION CROSS MANAGER V7.1	
	1	6ES7 658-1FX08-2YA5	SOFTWARE SIMATIC PCS 7 VERSION TRAIL V8.0	
	1	6ES7 658-1DX08-2YB5	SOFTWARE SIMATIC PCS 7 IMPORT EXPORT ASSISTANT V8.0	
Operator System				
2		6ES7660-2AA50-1CB0	SIMATIC PCS 7 INDUSTRIAL WORKSTATION IPC847C, CORE I7, ES/OS SINGLESTATION, RAID1 (500GB INTERNAL), 8GB DDR3, BCE, MULTI VGA 2-SCREEN CARD PCS 7 V8.0 SP1, WIN 7	¹⁾
2		6ES7 658-2AA08-0YA0	SOFTWARE SIMATIC PCS 7 OS SOFTWARE SINGLE STATION V8.0 (PO 100)	²⁾
	2	6ES7 652-0XD08-2YB5	SOFTWARE SIMATIC PCS 7 SFC VISUALIZATION V8.0	

5 System with multiple OS single stations

Required	Optional	Product number	Product description	Note
Terminal bus				
1		6GK5 208-0BA10-2AA3	SIMATIC NET SCALANCE X208, MANAGED IE SWITCH, 8 X 10/100MBIT/S	³⁾
3		6XV1 870-3QH60	SIMATIC NET INDUSTRIAL ETHERNET TP CORD CABLE RJ45/RJ45, 6M	
System bus				
1		6GK5 208-0BA10-2AA3	SIMATIC NET SCALANCE X208, MANAGED IE SWITCH, 8 X 10/100MBIT/S	³⁾
4		6XV1 870-3QH60	SIMATIC NET INDUSTRIAL ETHERNET TP CORD CABLE RJ45/RJ45, 6M	
Automation system				
1		6ES7 654-6CN03-3BF0	SIMATIC PCS 7 SINGLE AS, CPU 410-5H, 1X DP-MODULE, 1x PROFINET-IO, SYSTEM EXPANSIONS CARD 1000 PO, AS RT PO 100, CP443-1IE, UR2 ALU RACK, 1 X UC 120/230V 10A POWER SUPPLY	⁴⁾

Note

- ¹⁾ If quad Multi VGA is available, the number of monitors must be increased accordingly.
- ²⁾ The number of POs can be increased later on by means of extra volume licenses.
- ³⁾ SCALANCE switch requires a 24VDC power supply (not listed).
- ⁴⁾ Please use the PCS 7 AS configurator, as the PCS 7 AS 410-5H is available in different versions, e.g. 24V DC or 110/230V AC.

5.4 Plain system configuration without OS server

For small and medium-sized plants, implementation is now also possible in a very plain system configuration without OS server. In this case, only OS single-user stations are used, and the number can be expanded up to a maximum of 8 single-user stations.

The separation, which is usually carried out by the system and terminal bus in an OS server / OS client structure, does not happen in this case and therefore there is a direct connection between each single-user station and the AS.

Figure 5-4 Plain system configuration

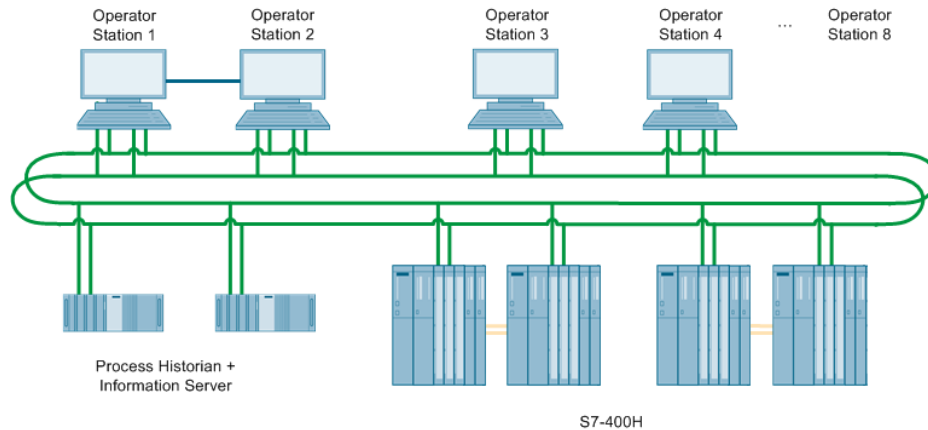

Bill of material for redundant OS single stations

Table 5-4

Required	Optional	Product number	Product description	Note
Engineering System				
1		6ES7 660-2AA31-1CA0	SIMATIC PCS 7 INDUSTRIAL WORKSTATION IPC847C, CORE I7, ES/OS SINGLESTATION, RAID1 (500GB FRONT MOUNTED), 8GB DDR3, INDUSTRIAL ETHERNET (CP1623), PCS 7 V8.0 SP1, WIN 7	
1		6GK1 162-3AA00	SIMATIC NET COMMUNICATION PROCESSOR CP 1623 PCI EXPRESS	1)
1		6GK1711-1EW08-2AA0	SIMATIC NET SOFTNET-IE RNA V8.2 REDUNDANT NETWORK ACCESS	2)
1		6ES7 658-5AX08-0YA5	SOFTWARE SIMATIC PCS 7 AS/OS ENGINEERING V8.0	
1		6GK1 716-0HB08-1AC0	SIMATIC NET, S7-REDCONNECT POWERPACK	4)
	1	6ES7 658-1CX17-2YA5	SOFTWARE SIMATIC PCS 7 VERSION CROSS MANAGER V7.1	
	1	6ES7 658-1FX08-2YA5	SOFTWARE SIMATIC PCS 7 VERSION TRAIL V8.0	
	1	6ES7 658-1DX08-2YB5	SOFTWARE SIMATIC PCS 7 IMPORT EXPORT ASSISTANT V8.0	

5 System with multiple OS single stations

Required	Optional	Product number	Product description	Note
Operator System				
3		6ES7 660-2AA31-1CA0	SIMATIC PCS 7 INDUSTRIAL WORKSTATION IPC847C, CORE I7, ES/OS SINGLESTATION, RAID1 (500GB FRONT MOUNTED), 8GB DDR3, INDUSTRIAL ETHERNET (CP1623), PCS 7 V8.0 SP1, WIN 7	
3		6GK1 162-3AA00	SIMATIC NET COMMUNICATION PROCESSOR CP 1623 PCI EXPRESS	1)
3		6GK1711-1EW08-2AA0	SIMATIC NET SOFTNET-IE RNA V8.2 REDUNDANT NETWORK ACCESS	2)
1		6ES7652-3AA08-2YA0	SOFTWARE SIMATIC PCS 7 OS SINGLE STATION REDUNDANCY V8.0 (PO 100)	3) 7)
3		6GK1 716-0HB08-1AC0	SIMATIC NET, S7-REDCONNECT POWERPACK	4)
	3	6ES7 652-0XD08-2YB5	SOFTWARE SIMATIC PCS 7 SFC VISUALIZATION V8.0	
Terminal / system bus				
3		6GK5 208-0BA10-2AA3	SIMATIC NET SCALANCE X208, MANAGED IE SWITCH, 8 X 10/100MBIT/S	5)
18		6XV1 870-3QH60	SIMATIC NET INDUSTRIAL ETHERNET TP CORD CABLE RJ45/RJ45, 6M	
Automation system				
2		6ES7 654-6CN33-1CF0	SIMATIC PCS 7 REDUNDANCY AS, 2X CPU 410-5H, 2 DP-MODULE, 2X PROFINET-IO, SYSTEM EXPANSION CARD 1000 PO, AS RT PO 100, 2 X 2 10M SYNC-MODULE AND 2 X 1M FO, 2 X CP443-1 IE/PN, 1 X UR2-H ALU RACK, 2 X UC 120/230V 10A RED. POWER SUPPLY	6)

Note

^{1) 2)} Required in case a redundant bus is selected.

³⁾ The number of POs can be increased later on by means of extra volume licenses.

⁴⁾ Required in case a redundant bus or a redundant automation system is selected.

⁵⁾ SCALANCE switch requires a 24VDC power supply (not listed).

⁶⁾ Please use the PCS 7 AS configurator, as the PCS 7 AS 410-5H is available in different versions, e.g. 24V DC or 110/230V AC.⁷⁾ The redundant OS single station is supplied with an RS-232 serial connection cable. If there is a long distance between the redundant systems, one can use an Ethernet connection as an alternative. This requires additional Ethernet network interface cards in the PCs.

6 Client/server system

Client/server system

Medium to large systems can benefit a lot from the SIMATIC PCS 7 client/server architecture. The central administration of real-time and historical values, easy entry of application changes and cost reduction are all features of SIMATIC PCS 7 systems. The basic system of a client/server architecture is composed of an OS server and two or more OS clients. The ES has a connection to both the terminal bus and the system bus, so that changes can be loaded from both the OSs and the ASs. If needed and when there are no engineering tasks pending, the ES can be used as an OS client.

Operation via server

If you operate no more than 4 OS clients on one OS server, you can use an OS server as an operator control and monitoring station.

Redundancy

With the use of a redundant OS server (optional redundant process historian), SIMATIC PCS 7 can support redundancy at all levels. Therefore, the accessing of OS clients to real-time/historical values and storing of historical data offer higher availability.

On the hardware level, the system supports redundant ring structures to ensure even there an increased availability.

Dual-Monitor

OS clients can be equipped with a "2 screen" or "4 screen" Multi VGA graphics card, which enables connection of up to four monitors per OS client. You can decide whether to use a Multi VGA card for each OS client.

Web Server

A dedicated OS client can be equipped with the SIMATIC PCS 7 Web server software, which enables operator control and monitoring of up to 50 web clients via Internet/Intranet. The server licensing allows more than 50 users to access one web server simultaneously.

Note

An OS server supports up to 32 OS clients.

6.1 Client/server

Figure 6-1

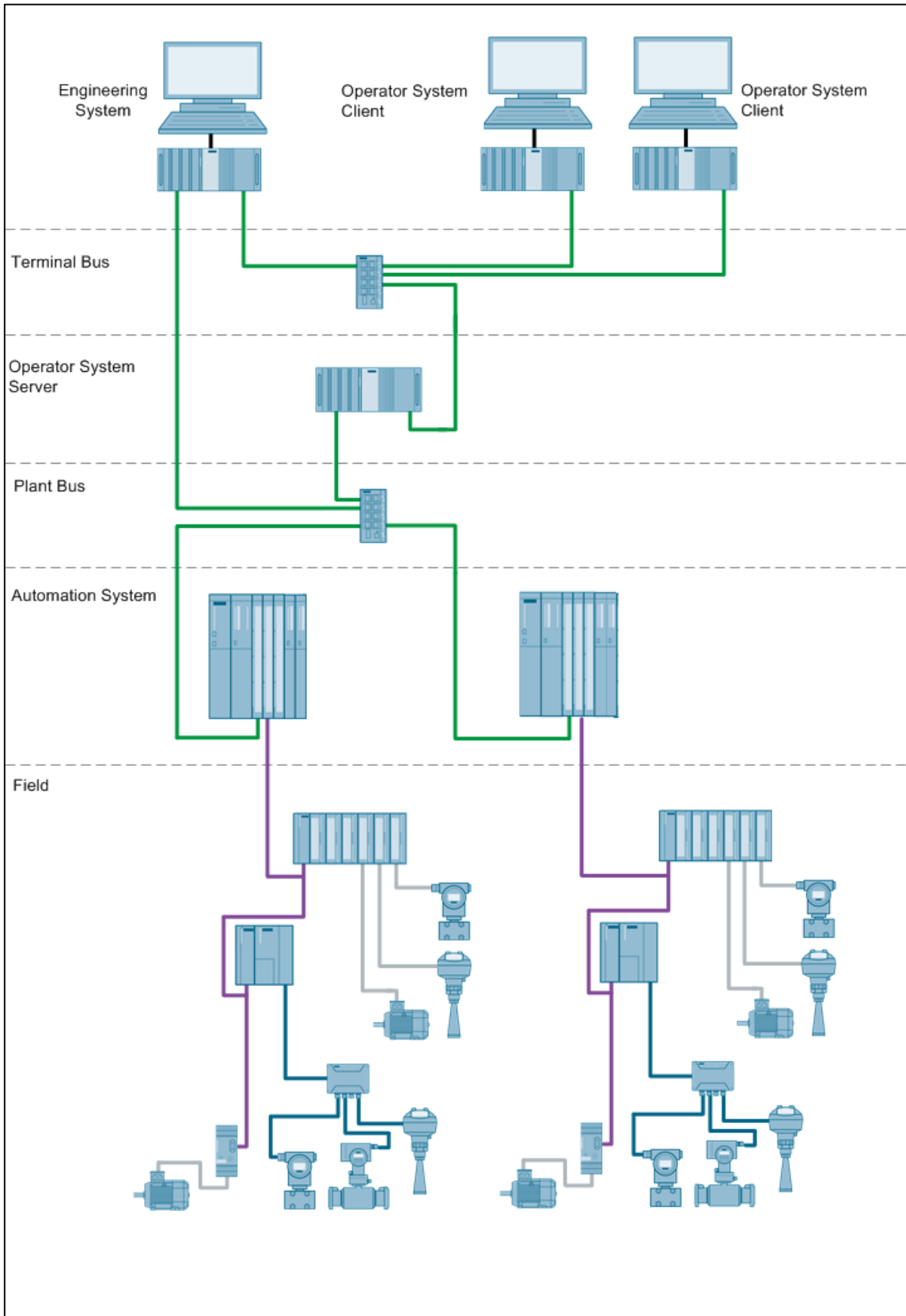

Bill of material for the client/server system

Table 6–1

Required	Optional	Product number	Product description	Note
Engineering System				
1		6ES7660-2AA30-1CA0	SIMATIC PCS 7 INDUSTRIAL WORKSTATION IPC847C, CORE I7, ES/OS SINGLESTATION, RAID1 (500GB INTERNAL), 8GB DDR3, BCE, PCS 7 V8.0 SP1, WIN 7	
1		6ES7 658-5AX08-0YA5	SOFTWARE SIMATIC PCS 7 AS/OS ENGINEERING V8.0	
	1	6ES7 658-1CX17-2YA5	SOFTWARE SIMATIC PCS 7 VERSION CROSS MANAGER V7.1	
	1	6ES7 658-1FX08-2YA5	SOFTWARE SIMATIC PCS 7 VERSION TRAIL V8.0	
	1	6ES7 658-1DX08-2YB5	SOFTWARE SIMATIC PCS 7 IMPORT EXPORT ASSISTANT V8.0	
Operator System server				
1		6ES7660-2BA30-1DA0	SIMATIC PCS 7 INDUSTRIAL WORKSTATION IPC847C, CORE I7, OS SERVER, RAID1 (500GB INTERNAL), 8GB DDR3, BCE, PCS 7 V8.0 SP1, WIN SERVER 2008	
1		6ES7 658-2BA08-0YA0	SOFTWARE SIMATIC PCS 7 OS SOFTWARE SERVER V8.0 (PO 100)	¹⁾
Operator System client				
2		6ES7660-1CA18-1CA0	SIMATIC PCS 7 INDUSTRIAL WORKSTATION IPC647C, CORE I7, OS CLIENT, 500GB INTERNAL, 4GB DDR3, PCS 7 V8.0 SP1, WIN 7	
2		6ES7 658-2CX08-0YB5	SOFTWARE SIMATIC PCS 7 OS CLIENT V8.0	
	2	6ES7 652-0XD08-2YB5	SOFTWARE SIMATIC PCS 7 SFC VISUALIZATION V8.0	

Required	Optional	Product number	Product description	Note
Terminal bus				
1		6GK5 208-0BA10-2AA3	SIMATIC NET SCALANCE X208, MANAGED IE SWITCH, 8 X 10/100MBIT/S	²⁾
4		6XV1 870-3QH60	SIMATIC NET INDUSTRIAL ETHERNET TP CORD CABLE RJ45/RJ45, 6M	
System bus				
1		6GK5 208-0BA10-2AA3	SIMATIC NET SCALANCE X208, MANAGED IE SWITCH, 8 X 10/100MBIT/S	²⁾
4		6XV1 870-3QH60	SIMATIC NET INDUSTRIAL ETHERNET TP CORD CABLE RJ45/RJ45, 6M	
Automation system				
2		6ES7 654-6CN03-3BF0	SIMATIC PCS 7 SINGLE AS, CPU 410-5H, 1X DP-MODULE, 1x PROFINET-IO, SYSTEM EXPANSIONS CARD 1000 PO, AS RT PO 100, CP443-1IE, UR2 ALU RACK, 1 X UC 120/230V 10A POWER SUPPLY	³⁾

Note

- ¹⁾ The number of POs can be increased later on by means of extra volume licenses.
- ²⁾ SCALANCE switch requires a 24VDC power supply (not listed).
- ³⁾ Please use the PCS 7 AS configurator, as the PCS 7 AS 410-5H is available in different versions, e.g. 24V DC or 110/230V AC.

6.2 Client/server with operator control and monitoring on the ES and OS Server

Figure 6-2

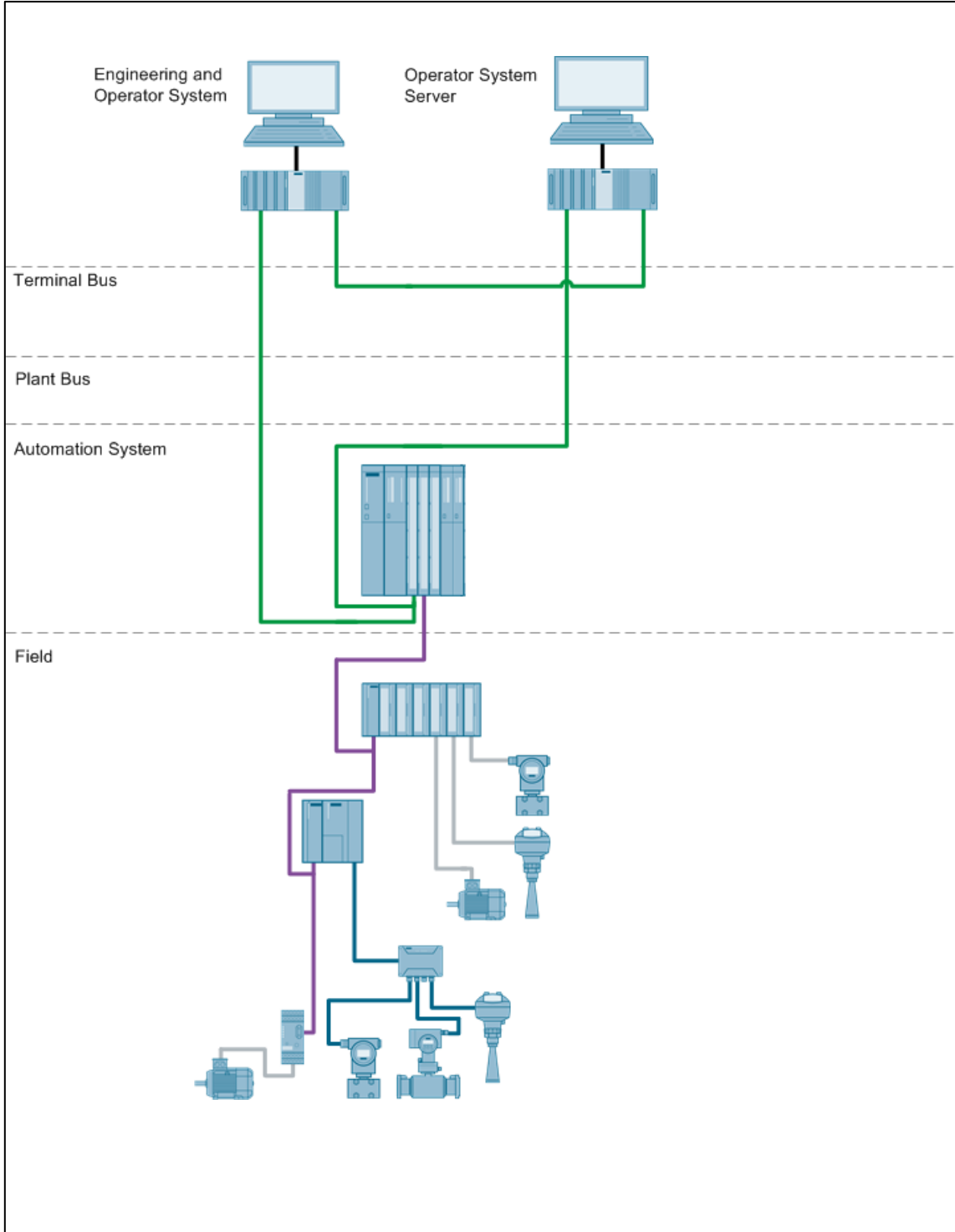

Bill of material for client/server architecture with operator control and monitoring on the ES and OS Server

Table 6–2

Required	Optional	Product number	Product description	Note
Engineering System				
1		6ES7660-2AA30-1CA0	SIMATIC PCS 7 INDUSTRIAL WORKSTATION IPC847C, CORE I7, ES/OS SINGLESTATION, RAID1 (500GB INTERNAL), 8GB DDR3, BCE, PCS 7 V8.0 SP1, WIN 7	
1		6ES7 658-5AX08-0YA5	SOFTWARE SIMATIC PCS 7 AS/OS ENGINEERING V8.0	
	1	6ES7 652-0XD08-2YB5	SOFTWARE SIMATIC PCS 7 SFC VISUALIZATION V8.0	
	1	6ES7 658-1CX17-2YA5	SOFTWARE SIMATIC PCS 7 VERSION CROSS MANAGER V7.1	
	1	6ES7 658-1FX08-2YA5	SOFTWARE SIMATIC PCS 7 VERSION TRAIL V8.0	
	1	6ES7 658-1DX08-2YB5	SOFTWARE SIMATIC PCS 7 IMPORT EXPORT ASSISTANT V8.0	
1		6ES7 658-2CX08-0YB5	SOFTWARE SIMATIC PCS 7 OS CLIENT V8.0	2)
Operator System server				
1		6ES7660-2BA30-1DA0	SIMATIC PCS 7 INDUSTRIAL WORKSTATION IPC847C, CORE I7, OS SERVER, RAID1 (500GB INTERNAL), 8GB DDR3, BCE, PCS 7 V8.0 SP1, WIN SERVER 2008	
1		6ES7 648-0CB00-0YA0	SIMATIC PC KEYBOARD GERMAN / INTERNATIONAL USB INTERFACE	
1		6ES7 658-2BA08-0YA0	SOFTWARE SIMATIC PCS 7 OS SOFTWARE SERVER V8.0 (PO 100)	1)
	1	6ES7 652-0XD08-2YB5	SOFTWARE SIMATIC PCS 7 SFC VISUALIZATION V8.0	

Required	Optional	Product number	Product description	Note
Terminal bus				
1		6XV1 870-3RH60	SIMATIC NET INDUSTRIAL ETHERNET TP XP CORD RJ45/RJ45, 6M	
System bus				
2		6XV1 870-3QH60	SIMATIC NET INDUSTRIAL ETHERNET TP CORD CABLE RJ45/RJ45, 6M	
Automation system				
1		6ES7 654-6CP03-3BF0	SIMATIC PCS 7 SINGLE AS, CPU 410-5H, 1X DP-MODULE, 1x PROFINET-IO, SYSTEM EXPANSIONS CARD 1600 PO, AS RT PO 100, CP443-1IE, UR2 ALU RACK, 1 X UC 120/230V 10A POWER SUPPLY	³⁾

Note

- ¹⁾ The number of POs can be increased later on by means of extra volume licenses.
- ²⁾ The maximum number of remote OS clients via operator control on is three. One OS client with dual monitor is equivalent to 2 OS clients. A maximum of 4 monitors can be controlled remotely from an OS server.
- ³⁾ Please use the PCS 7 AS configurator, as the PCS 7 AS 410-5H is available in different versions, e.g. 24V DC or 110/230V AC.

6.3 Client/server operation on a server architecture

Figure 6-3

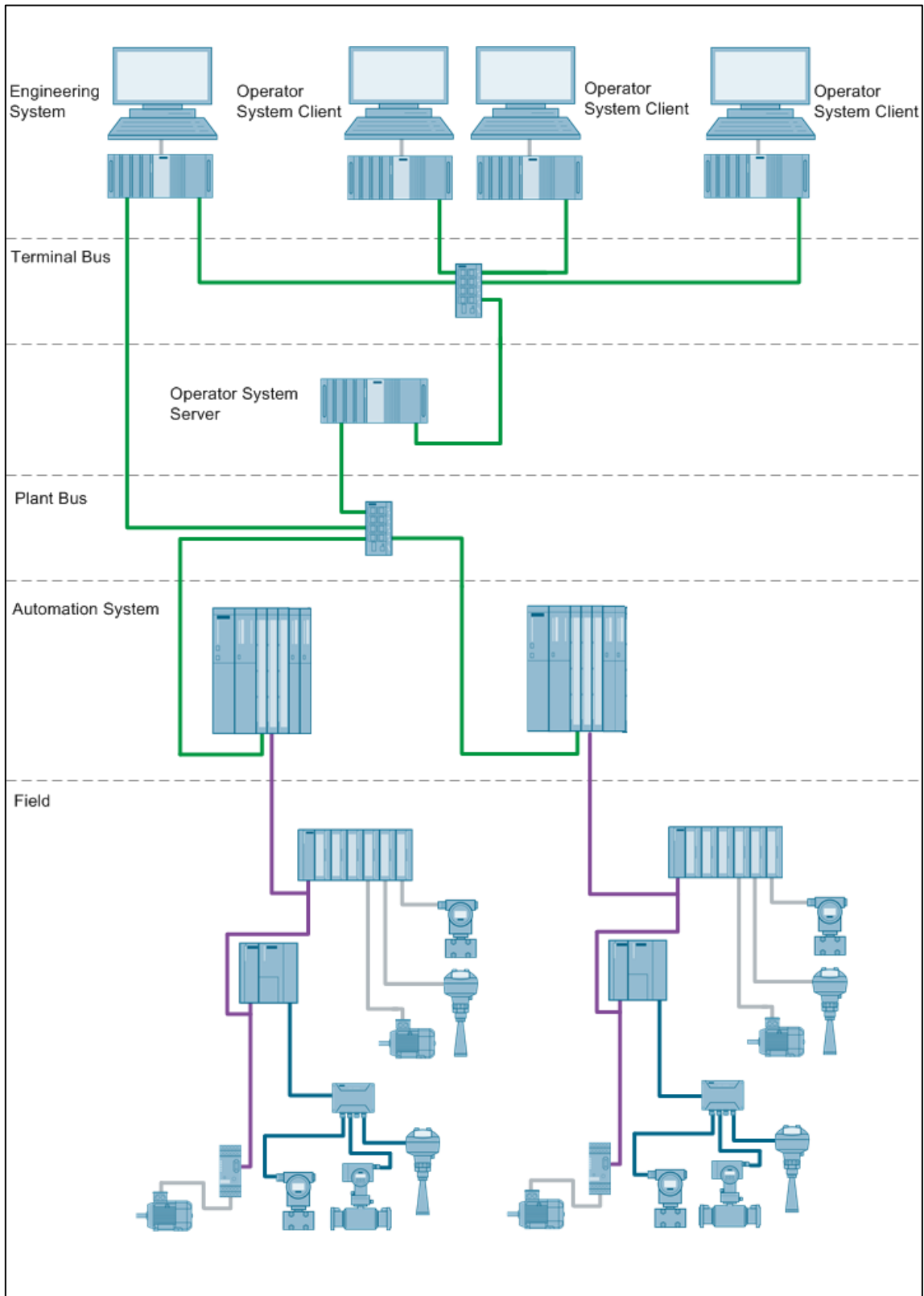

Copyright © Siemens AG 2013 All rights reserved

Bill of material for client/server operation on a server

Table 6–3

Required	Optional	Product number	Product description	Note
Engineering System				
1		6ES7660-2AA30-1CA0	SIMATIC PCS 7 INDUSTRIAL WORKSTATION IPC847C, CORE I7, ES/OS SINGLESTATION, RAID1 (500GB INTERNAL), 8GB DDR3, BCE, PCS 7 V8.0 SP1, WIN 7	
1		6ES7 658-5AX08-0YA5	SOFTWARE SIMATIC PCS 7 AS/OS ENGINEERING V8.0	
	1	6ES7 658-1CX17-2YA5	SOFTWARE SIMATIC PCS 7 VERSION CROSS MANAGER V7.1	
	1	6ES7 658-1FX08-2YA5	SOFTWARE SIMATIC PCS 7 VERSION TRAIL V8.0	
	1	6ES7 658-1DX08-2YB5	SOFTWARE SIMATIC PCS 7 IMPORT EXPORT ASSISTANT V8.0	
Operator System server				
1		6ES7660-2BA30-1DA0	SIMATIC PCS 7 INDUSTRIAL WORKSTATION IPC847C, CORE I7, OS SERVER, RAID1 (500GB INTERNAL), 8GB DDR3, BCE, PCS 7 V8.0 SP1, WIN SERVER 2008	
1		6ES7 658-2BA08-0YA0	SOFTWARE SIMATIC PCS 7 OS SOFTWARE SERVER V8.0 (PO 100)	¹⁾
	1	6ES7 652-0XD08-2YB5	SOFTWARE SIMATIC PCS 7 SFC VISUALIZATION V8.0	
Operator System client				
3		6ES7660-1CA18-1CA0	SIMATIC PCS 7 INDUSTRIAL WORKSTATION IPC647C, CORE I7, OS CLIENT, 500GB INTERNAL, 4GB DDR3, PCS 7 V8.0 SP1, WIN 7	²⁾
3		6ES7 658-2CX08-0YB5	SOFTWARE SIMATIC PCS 7 OS CLIENT V8.0	
	3	6ES7 652-0XD08-2YB5	SOFTWARE SIMATIC PCS 7 SFC VISUALIZATION V8.0	

Required	Optional	Product number	Product description	Note
Terminal bus				
1		6GK5 208-0BA10-2AA3	SIMATIC NET SCALANCE X208, MANAGED IE SWITCH, 8 X 10/100MBIT/S	³⁾
5		6XV1 870-3QH60	SIMATIC NET INDUSTRIAL ETHERNET TP CORD CABLE RJ45/RJ45, 6M	
System bus				
1		6GK5 208-0BA10-2AA3	SIMATIC NET SCALANCE X208, MANAGED IE SWITCH, 8 X 10/100MBIT/S	³⁾
4		6XV1 870-3QH60	SIMATIC NET INDUSTRIAL ETHERNET TP CORD CABLE RJ45/RJ45, 6M	
Automation system				
2		6ES7 654-6CN03-3BF0	SIMATIC PCS 7 SINGLE AS, CPU 410-5H, 1X DP-MODULE, 1x PROFINET-IO, SYSTEM EXPANSIONS CARD 1000 PO, AS RT PO 100, CP443-1IE, UR2 ALU RACK, 1 X UC 120/230V 10A POWER SUPPLY	⁴⁾

Note

- ¹⁾ The number of POs can be increased later on by means of extra volume licenses.
- ²⁾ The maximum number of remote OS clients via operator control on is three. One OS client with dual monitor is equivalent to 2 OS clients. A maximum of 4 monitors can be controlled remotely from an OS server.
- ³⁾ SCALANCE switch requires a 24VDC power supply (not listed).
- ⁴⁾ Please use the PCS 7 AS configurator, as the PCS 7 AS 410-5H is available in different versions, e.g. 24V DC or 110/230V AC.

6.4 Client/server operation on a redundant server architecture

Figure 6-4

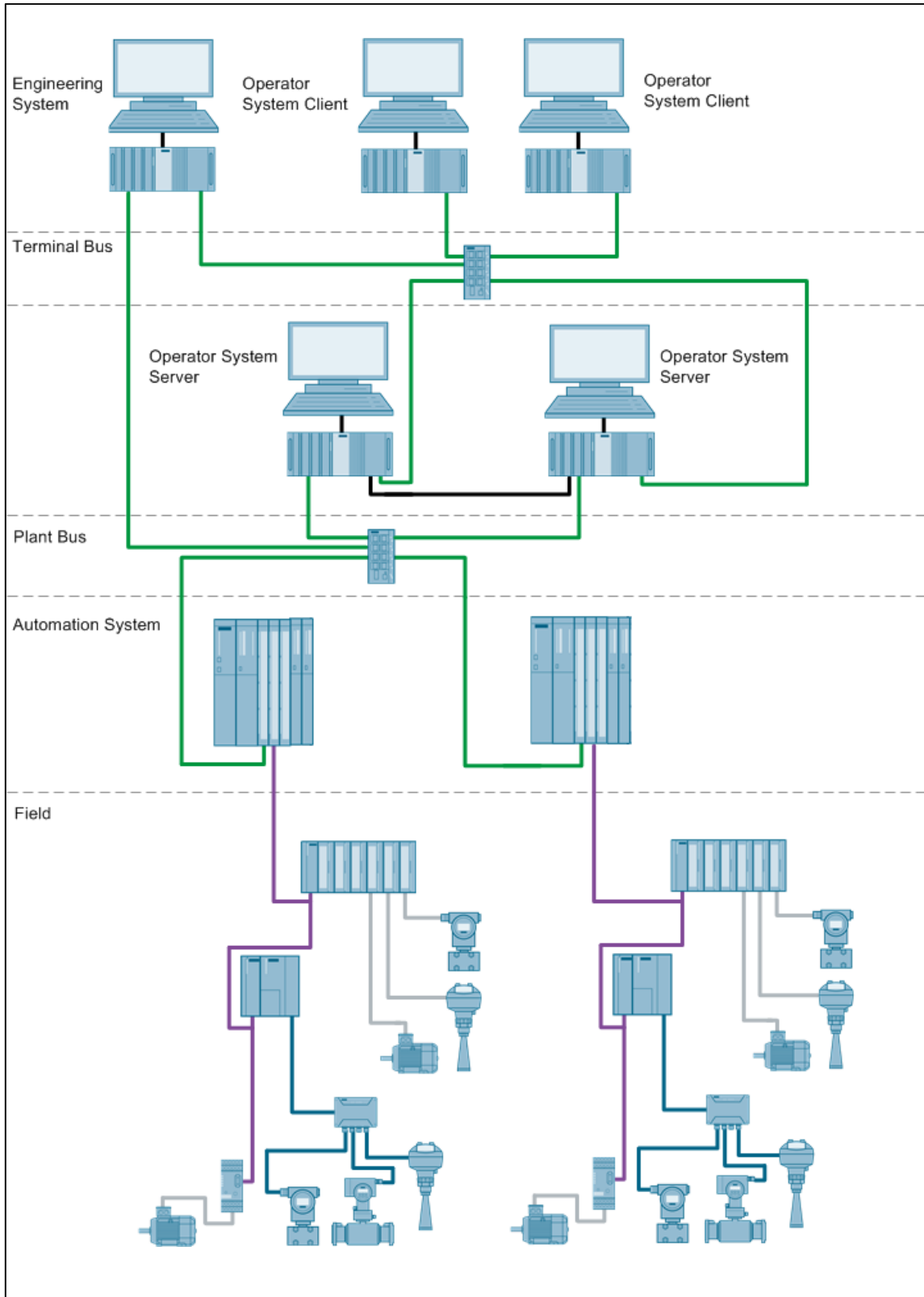

Bill of material for client/server operation on a redundant server

Table 6-4

Required	Optional	Product number	Product description	Note
Engineering System				
1		6ES7660-2AA30-1CA0	SIMATIC PCS 7 INDUSTRIAL WORKSTATION IPC847C, CORE I7, ES/OS SINGLESTATION, RAID1 (500GB INTERNAL), 8GB DDR3, BCE, PCS 7 V8.0 SP1, WIN 7	
1		6ES7 658-5AX08-0YA5	SOFTWARE SIMATIC PCS 7 AS/OS ENGINEERING V8.0	
	1	6ES7 658-1CX17-2YA5	SOFTWARE SIMATIC PCS 7 VERSION CROSS MANAGER V7.1	
	1	6ES7 658-1FX08-2YA5	SOFTWARE SIMATIC PCS 7 VERSION TRAIL V8.0	
	1	6ES7 658-1DX08-2YB5	SOFTWARE SIMATIC PCS 7 IMPORT EXPORT ASSISTANT V8.0	
Operator System server				
2		6ES7660-2BA30-1DA0	SIMATIC PCS 7 INDUSTRIAL WORKSTATION IPC847C, CORE I7, OS SERVER, RAID1 (500GB INTERNAL), 8GB DDR3, BCE, PCS 7 V8.0 SP1, WIN SERVER 2008	
1		6ES7 652-3BA08-2YA0	SOFTWARE SIMATIC PCS 7 OS SERVER REDUNDANCY V8.0 (PO 100)	1) 5)
	2	6ES7 652-0XD08-2YB5	SOFTWARE SIMATIC PCS 7 SFC VISUALIZATION V8.0	
Operator System client				
2		6ES7660-1CA18-1CA0	SIMATIC PCS 7 INDUSTRIAL WORKSTATION IPC647C, CORE I7, OS CLIENT, 500GB INTERNAL, 4GB DDR3, PCS 7 V8.0 SP1, WIN 7	2)
2		6ES7 658-2CX08-0YB5	SOFTWARE SIMATIC PCS 7 OS CLIENT V8.0	
	2	6ES7 652-0XD08-2YB5	SOFTWARE SIMATIC PCS 7 SFC VISUALIZATION V8.0	

Required	Optional	Product number	Product description	Note
Terminal bus				
1		6GK5 208-0BA10-2AA3	SIMATIC NET SCALANCE X208, MANAGED IE SWITCH, 8 X 10/100MBIT/S	³⁾
5		6XV1 870-3QH60	SIMATIC NET INDUSTRIAL ETHERNET TP CORD CABLE RJ45/RJ45, 6M	
System bus				
1		6GK5 208-0BA10-2AA3	SIMATIC NET SCALANCE X208, MANAGED IE SWITCH, 8 X 10/100MBIT/S	³⁾
4		6XV1 870-3QH60	SIMATIC NET INDUSTRIAL ETHERNET TP CORD CABLE RJ45/RJ45, 6M	
Automation system				
2		6ES7 654-6CN03-3BF0	SIMATIC PCS 7 SINGLE AS, CPU 410-5H, 1X DP-MODULE, 1x PROFINET-IO, SYSTEM EXPANSIONS CARD 1000 PO, AS RT PO 100, CP443-1IE, UR2 ALU RACK, 1 X UC 120/230V 10A POWER SUPPLY	⁴⁾

Note

- ¹⁾ The number of POs can be increased later on by means of extra volume licenses.
- ²⁾ The maximum number of remote OS clients on the redundant OS server is two. One OS client with dual monitor is equivalent to 2 OS clients.
- ³⁾ SCALANCE switch requires a 24VDC power supply (not listed).
- ⁴⁾ Please use the PCS 7 AS configurator, as the PCS 7 AS 410-5H is available in different versions, e.g. 24V DC or 110/230V AC.
- ⁵⁾ The redundant OS server is supplied with an RS-232 serial connection cable. If there is a long distance between the redundant systems, one can use an Ethernet connection as an alternative. This requires additional Ethernet network interface cards in the systems.

6.5 Redundant client/server

Figure 6-5

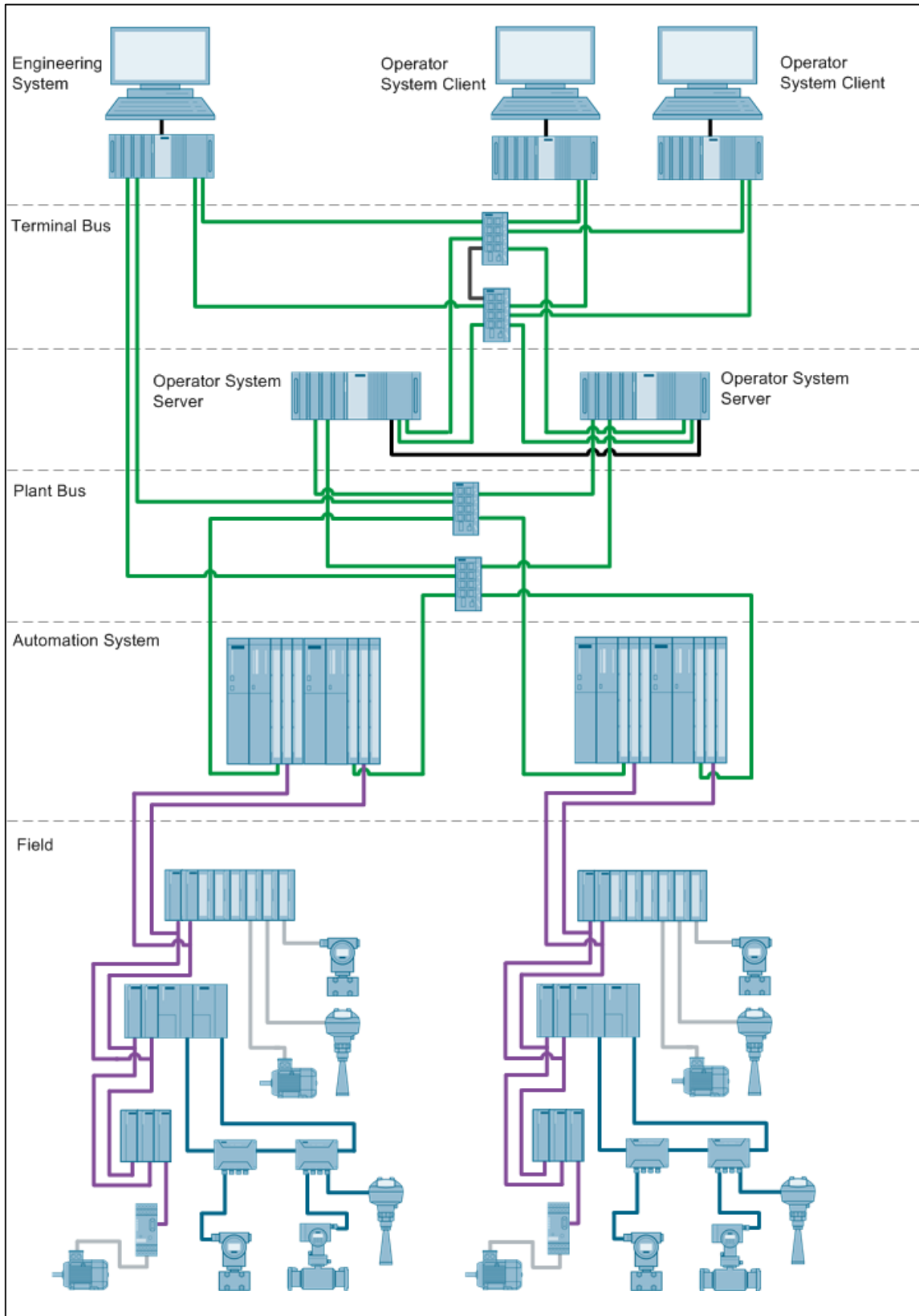

Copyright © Siemens AG 2013 All rights reserved

Bill of material for the redundant client/server system

Table 6–5

Required	Optional	Product number	Product description	Note
Engineering System				
1		6ES7 660-2AA31-1CA0	SIMATIC PCS 7 INDUSTRIAL WORKSTATION IPC847C, CORE I7, ES/OS SINGLESTATION, RAID1 (500GB FRONT MOUNTED), 8GB DDR3, INDUSTRIAL ETHERNET (CP1623), PCS 7 V8.0 SP1, WIN 7	
1		6ES7 658-5AX08-0YA5	SOFTWARE SIMATIC PCS 7 AS/OS ENGINEERING V8.0	
1		6GK1 162-3AA00	SIMATIC NET COMMUNICATION PROCESSOR CP 1623 PCI EXPRESS	1)
1		6GK1 716-0HB08-1AC0	SIMATIC NET, S7-REDCONNECT POWERPACK	4)
1		6ES7 652-0XX01-1XF1	SIMATIC PCS 7 REDUNDANT TERMINAL BUS ADAPTER PACKAGE, 2 X INTEL PCI-E (EXPRESS) NETWORK CARD	2)
	1	6ES7 658-1CX17-2YA5	SOFTWARE SIMATIC PCS 7 VERSION CROSS MANAGER V7.1	
	1	6ES7 658-1FX08-2YA5	SOFTWARE SIMATIC PCS 7 VERSION TRAIL V8.0	
	1	6ES7 658-1DX08-2YB5	SOFTWARE SIMATIC PCS 7 IMPORT EXPORT ASSISTANT V8.0	
Operator System server				
2		6ES7660-2BB31-1DA0	SIMATIC PCS 7 INDUSTRIAL WORKSTATION IPC847C, CORE I7, OS SERVER, RAID1 (500GB FRONT MOUNTED), 8GB DDR3, INDUSTRIAL ETHERNET (CP1623), PCS 7 V8.0 SP1, WIN SERVER 2008	
1		6ES7 652-3BA08-2YA0	SOFTWARE SIMATIC PCS 7 OS SERVER REDUNDANCY V8.0 (PO 100)	3) 7)
2		6GK1 162-3AA00	SIMATIC NET COMMUNICATION PROCESSOR CP 1623 PCI EXPRESS	1)
2		6GK1 716-0HB08-1AC0	SIMATIC NET, S7-REDCONNECT POWERPACK	4)
2		6ES7 652-0XX01-1XF1	SIMATIC PCS 7 REDUNDANT TERMINAL BUS ADAPTER PACKAGE, 2 X INTEL PCI-E (EXPRESS) NETWORK CARD	2)
Operator System client				
2		6ES7660-1CA18-1CA0	SIMATIC PCS 7 INDUSTRIAL WORKSTATION IPC647C, CORE I7, OS CLIENT, 500GB INTERNAL, 4GB DDR3, PCS 7 V8.0 SP1, WIN 7	
2		6ES7 652-0XX01-1XF1	SIMATIC PCS 7 REDUNDANT TERMINAL BUS ADAPTER PACKAGE, 2 X INTEL PCI-E (EXPRESS) NETWORK CARD	2)
2		6ES7 658-2CX08-0YB5	SOFTWARE SIMATIC PCS 7 OS CLIENT V8.0	
	2	6ES7 652-0XD08-2YB5	SOFTWARE SIMATIC PCS 7 SFC VISUALIZATION V8.0	

Required	Optional	Product number	Product description	Note
Terminal bus				
2		6GK5 208-0BA10-2AA3	SIMATIC NET SCALANCE X208, MANAGED IE SWITCH, 8 X 10/100MBIT/S	⁵⁾
12		6XV1 870-3QH60	SIMATIC NET INDUSTRIAL ETHERNET TP CORD CABLE RJ45/RJ45, 6M	
System bus				
2		6GK5 208-0BA10-2AA3	SIMATIC NET SCALANCE X208, MANAGED IE SWITCH, 8 X 10/100MBIT/S	⁵⁾
10		6XV1 870-3QH60	SIMATIC NET INDUSTRIAL ETHERNET TP CORD CABLE RJ45/RJ45, 6M	
Automation system				
2		6ES7 656-6CN33-1CF0	SIMATIC PCS 7 REDUNDANCY AS, 2X CPU 410-5H, 2 DP-MODULE, 2X PROFINET-IO, SYSTEM EXPANSION CARD 1000 PO, AS RT PO 100, 2 X 2 10M SYNC-MODULE AND 2 X 1M FO, 2 X CP443-1 IE/PN, 1 X UR2-H ALU RACK, 2 X UC 120/230V 10A RED. POWER SUPPLY	⁶⁾

Note

- ¹⁾ Required in case a redundant system bus is chosen
- ²⁾ Required in case a redundant terminal bus is chosen.
- ³⁾ The number of POs can be increased later on by means of extra volume licenses.
- ⁴⁾ Required in case a redundant system bus or a redundant automation system is chosen.
- ⁵⁾ SCALANCE switch requires a 24VDC power supply (not listed).
- ⁶⁾ Please use the PCS 7 AS configurator, as the PCS 7 AS 410-5H is available in different versions, e.g. 24V DC or 110/230V AC.
- ⁷⁾ The redundant OS server is supplied with an RS-232 serial connection cable. If there is a long distance between the redundant systems, one can use an Ethernet connection as an alternative. This requires additional Ethernet network interface cards in the systems.

6.6 Client/server system with Web Server

Figure 6-6

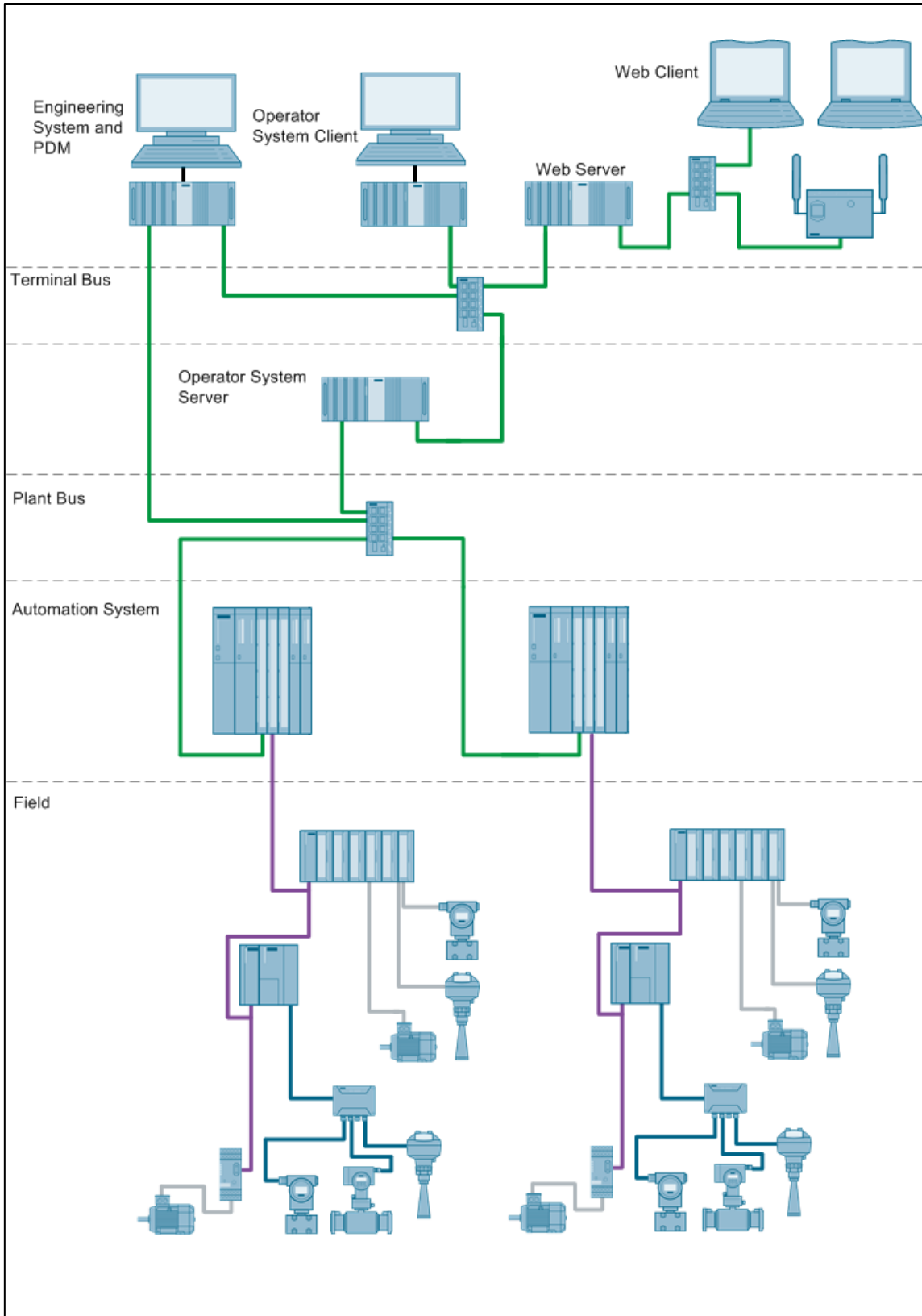

Bill of material for the client/server system with Web Server

Table 6–6

Required	Optional	Product number	Product description	Note
Engineering System				
1		6ES7660-2AA30-1CA0	SIMATIC PCS 7 INDUSTRIAL WORKSTATION IPC847C, CORE I7, ES/OS SINGLESTATION, RAID1 (500GB INTERNAL), 8GB DDR3, BCE, PCS 7 V8.0 SP1, WIN 7	
1		6ES7 658-5AX08-0YA5	SOFTWARE SIMATIC PCS 7 AS/OS ENGINEERING V8.0	
	1	6ES7 658-1CX17-2YA5	SOFTWARE SIMATIC PCS 7 VERSION CROSS MANAGER V7.1	
	1	6ES7 658-1FX08-2YA5	SOFTWARE SIMATIC PCS 7 VERSION TRAIL V8.0	
	1	6ES7 658-1DX08-2YB5	SOFTWARE SIMATIC PCS 7 IMPORT EXPORT ASSISTANT V8.0	
Operator System server				
1		6ES7660-2BA30-1DA0	SIMATIC PCS 7 INDUSTRIAL WORKSTATION IPC847C, CORE I7, OS SERVER, RAID1 (500GB INTERNAL), 8GB DDR3, BCE, PCS 7 V8.0 SP1, WIN SERVER 2008	
1		6ES7 658-2BA08-0YA0	SOFTWARE SIMATIC PCS 7 OS SOFTWARE SERVER V8.0 (PO 100)	¹⁾
Operator System client				
1		6ES7660-1CA18-1CA0	SIMATIC PCS 7 INDUSTRIAL WORKSTATION IPC647C, CORE I7, OS CLIENT, 500GB INTERNAL, 4GB DDR3, PCS 7 V8.0 SP1, WIN 7	
1		6ES7 658-2CX08-0YB5	SOFTWARE SIMATIC PCS 7 OS CLIENT V8.0	
	1	6ES7 652-0XD08-2YB5	SOFTWARE SIMATIC PCS 7 SFC VISUALIZATION V8.0	
Web Server				
1		6ES7660-2BA30-1DA0	SIMATIC PCS 7 INDUSTRIAL WORKSTATION IPC847C, CORE I7, OS SERVER, RAID1 (500GB INTERNAL), 8GB DDR3, BCE, PCS 7 V8.0 SP1, WIN SERVER 2008	
1		6ES7 658-2CX08-0YB5	SOFTWARE SIMATIC PCS 7 OS CLIENT V8.0	
1		6ES7 658-2GX08-2YB0	SOFTWARE SIMATIC PCS 7 WEB SERVER BASIC V8.0	
1		6ES7 658-2GF00-0XB0	SOFTWARE SIMATIC PCS 7 WEB SERVER (5 CLIENTS)	²⁾

Required	Optional	Product number	Product description	Note
Terminal bus				
1		6GK5 208-0BA10-2AA3	SIMATIC NET SCALANCE X208, MANAGED IE SWITCH, 8 X 10/100MBIT/S	³⁾
7		6XV1 870-3QH60	SIMATIC NET INDUSTRIAL ETHERNET TP CORD CABLE RJ45/RJ45, 6M	
System bus				
1		6GK5 208-0BA10-2AA3	SIMATIC NET SCALANCE X208, MANAGED IE SWITCH, 8 X 10/100MBIT/S	³⁾
4		6XV1 870-3QH60	SIMATIC NET INDUSTRIAL ETHERNET TP CORD CABLE RJ45/RJ45, 6M	
Automation system				
2		6ES7 654-6CN03-3BF0	SIMATIC PCS 7 SINGLE AS, CPU 410-5H, 1X DP-MODULE, 1x PROFINET-IO, SYSTEM EXPANSIONS CARD 1000 PO, AS RT PO 100, CP443-1IE, UR2 ALU RACK, 1 X UC 120/230V 10A POWER SUPPLY	⁴⁾

Note

Laptops that are used as web clients are not listed. Wireless LAN that is used for laptop connection is not listed.

¹⁾ The number of POs can be increased later on by means of extra volume licenses.

²⁾ The number of web clients can be increased later on by means of cumulative web server licenses.

³⁾ SCALANCE switch requires a 24VDC power supply (not listed).

⁴⁾ Please use the PCS 7 AS configurator, as the PCS 7 AS 410-5H is available in different versions, e.g. 24V DC or 110/230V AC.

6.7 Client/server system with DataMonitor server

Figure 6-7

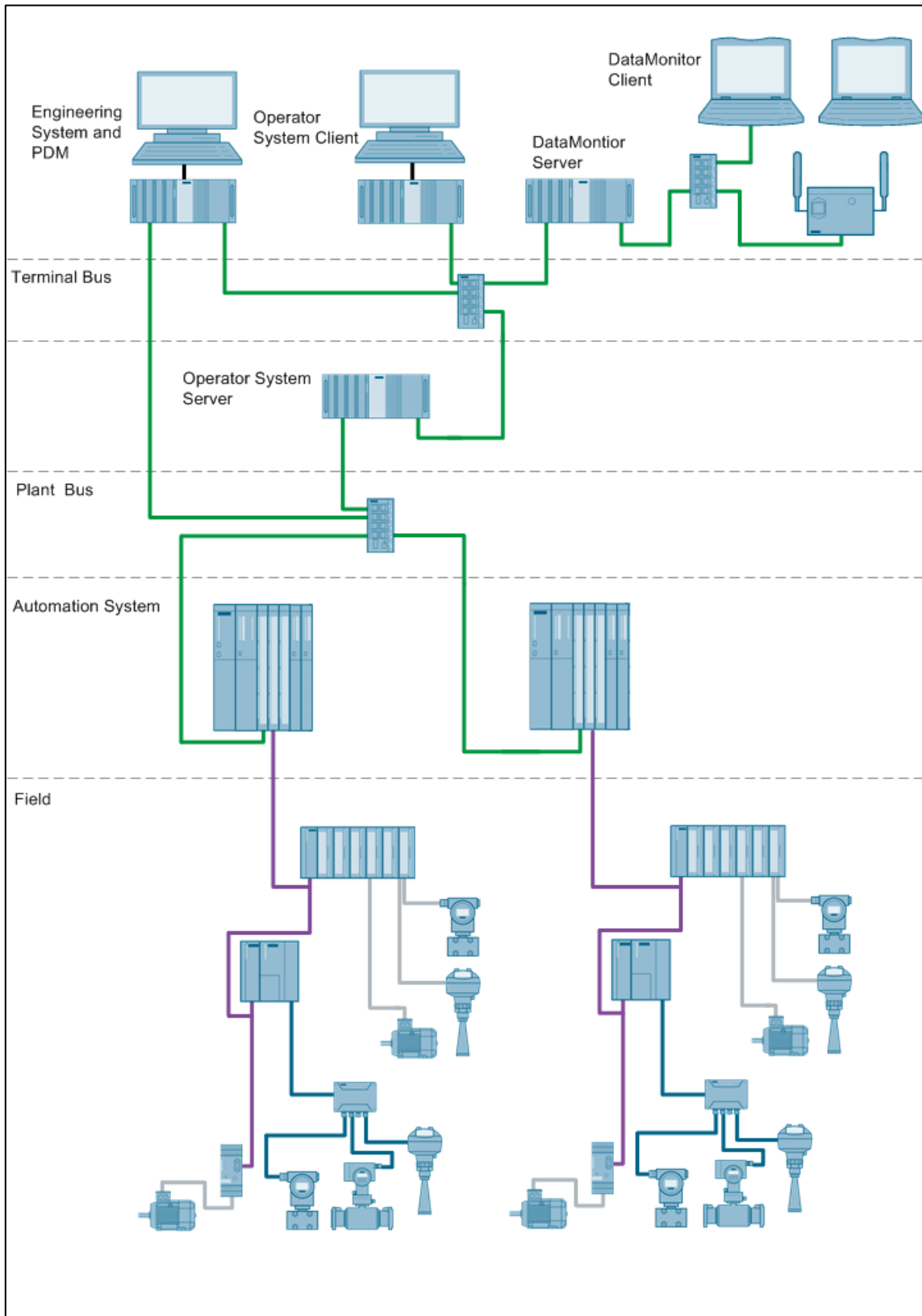

Copyright © Siemens AG 2013 All rights reserved

Bill of material for the client/server system with DataMonitor server

Table 6–7

Required	Optional	Product number	Product description	Note
Engineering System				
1		6ES7660-2AA30-1CA0	SIMATIC PCS 7 INDUSTRIAL WORKSTATION IPC847C, CORE I7, ES/OS SINGLESTATION, RAID1 (500GB INTERNAL), 8GB DDR3, BCE, PCS 7 V8.0 SP1, WIN 7	
1		6ES7 658-5AX08-0YA5	SOFTWARE SIMATIC PCS 7 AS/OS ENGINEERING V8.0	
	1	6ES7 658-1CX17-2YA5	SOFTWARE SIMATIC PCS 7 VERSION CROSS MANAGER V7.1	
	1	6ES7 658-1FX08-2YA5	SOFTWARE SIMATIC PCS 7 VERSION TRAIL V8.0	
	1	6ES7 658-1DX08-2YB5	SOFTWARE SIMATIC PCS 7 IMPORT EXPORT ASSISTANT V8.0	
Operator System server				
1		6ES7660-2BA30-1DA0	SIMATIC PCS 7 INDUSTRIAL WORKSTATION IPC847C, CORE I7, OS SERVER, RAID1 (500GB INTERNAL), 8GB DDR3, BCE, PCS 7 V8.0 SP1, WIN SERVER 2008	
1		6ES7 658-2BA08-0YA0	SOFTWARE SIMATIC PCS 7 OS SOFTWARE SERVER V8.0 (PO 100)	¹⁾
Operator System client				
1		6ES7660-1CA18-1CA0	SIMATIC PCS 7 INDUSTRIAL WORKSTATION IPC647C, CORE I7, OS CLIENT, 500GB INTERNAL, 4GB DDR3, PCS 7 V8.0 SP1, WIN 7	
1		6ES7 658-2CX08-0YB5	SOFTWARE SIMATIC PCS 7 OS CLIENT V8.0	
	1	6ES7 652-0XD08-2YB5	SOFTWARE SIMATIC PCS 7 SFC VISUALIZATION V8.0	
DataMonitor Server				
1		6ES7660-2BA30-1DA0	SIMATIC PCS 7 INDUSTRIAL WORKSTATION IPC847C, CORE I7, OS SERVER, RAID1 (500GB INTERNAL), 8GB DDR3, BCE, PCS 7 V8.0 SP1, WIN SERVER 2008	²⁾
1		6ES7 658-2CX08-0YB5	SOFTWARE SIMATIC PCS 7 OS CLIENT V8.0	
1		6AV6 371-1DN07-0AX0	SOFTWARE SIMATIC WINCC/DATAMONITOR V7.0 SERVER AND CLIENT (3 CLIENTS)	

Required	Optional	Product number	Product description	Note
Terminal bus				
1		6GK5 208-0BA10-2AA3	SIMATIC NET SCALANCE X208, MANAGED IE SWITCH, 8 X 10/100MBIT/S	³⁾
7		6XV1 870-3QH60	SIMATIC NET INDUSTRIAL ETHERNET TP CORD CABLE RJ45/RJ45, 6M	
System bus				
1		6GK5 208-0BA10-2AA3	SIMATIC NET SCALANCE X208, MANAGED IE SWITCH, 8 X 10/100MBIT/S	³⁾
4		6XV1 870-3QH60	SIMATIC NET INDUSTRIAL ETHERNET TP CORD CABLE RJ45/RJ45, 6M	
Automation system				
2		6ES7 654-6CN03-3BF0	SIMATIC PCS 7 SINGLE AS, CPU 410-5H, 1X DP-MODULE, 1x PROFINET-IO, SYSTEM EXPANSIONS CARD 1000 PO, AS RT PO 100, CP443-1IE, UR2 ALU RACK, 1 X UC 120/230V 10A POWER SUPPLY	⁴⁾

Note

Laptops that are used as DataMonitoring clients are not listed. Wireless LAN that is used for laptop connection is not listed.

¹⁾ The number of POs can be increased later on by means of extra volume licenses.

²⁾ Installation of the DataMonitor server:
 - restore DVD (Windows Server 2003/2008)
 - software DataMonitor server
 - OS client and DataMonitor server licenses

³⁾ SCALANCE switch requires a 24VDC power supply (not listed).

⁴⁾ Please use the PCS 7 AS configurator, as the PCS 7 AS 410-5H is available in different versions, e.g. 24V DC or 110/230V AC.

6.8 Client/server system with terminal server

Figure 6-8

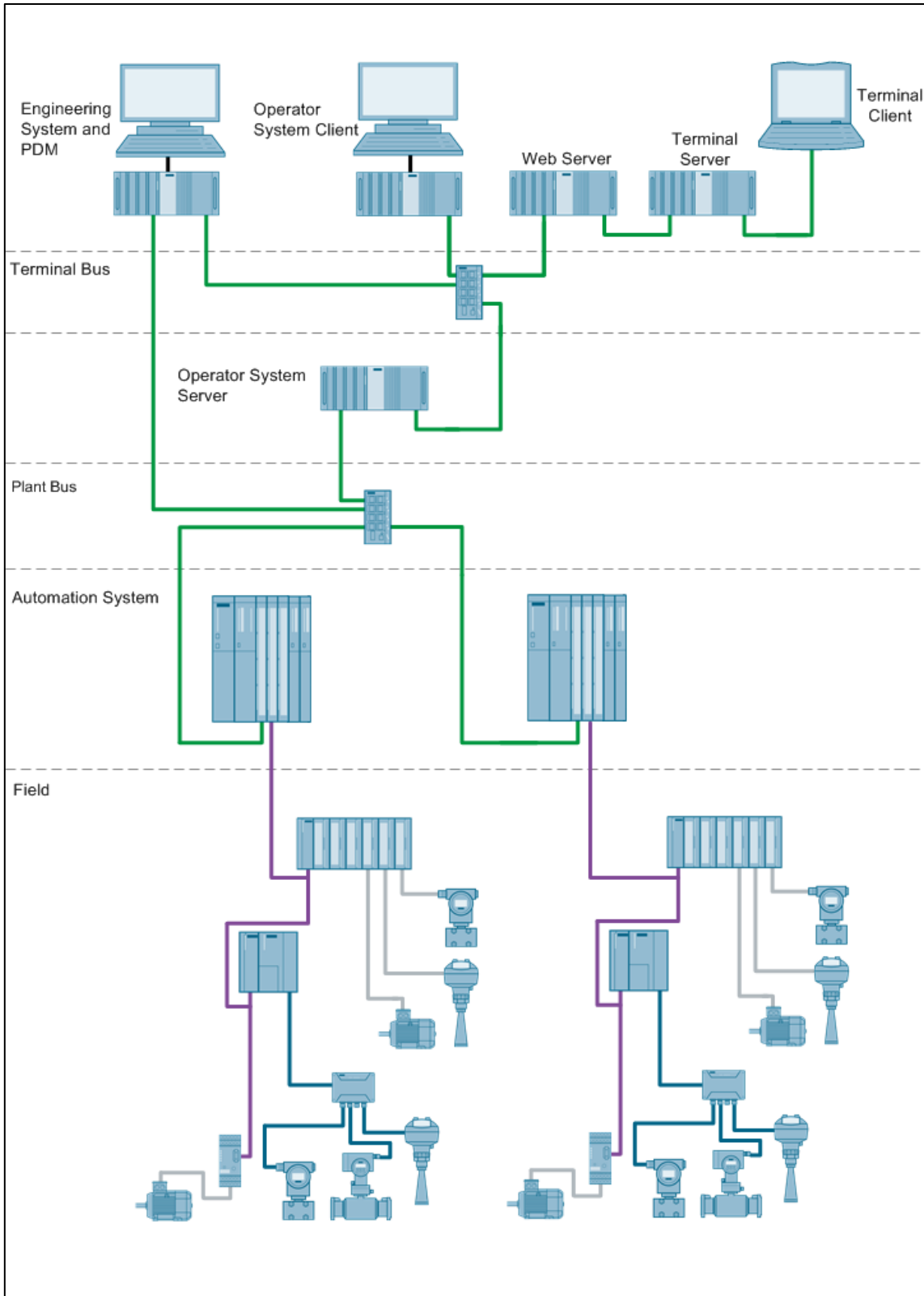

Copyright © Siemens AG 2013 All rights reserved

Bill of material for the client/server System with terminal server

Table 6–8

Required	Optional	Product number	Product description	Note
Engineering System				
1		6ES7660-2AA30-1CA0	SIMATIC PCS 7 INDUSTRIAL WORKSTATION IPC847C, CORE I7, ES/OS SINGLESTATION, RAID1 (500GB INTERNAL), 8GB DDR3, BCE, PCS 7 V8.0 SP1, WIN 7	
1		6ES7 658-5AX08-0YA5	SOFTWARE SIMATIC PCS 7 AS/OS ENGINEERING V8.0	
	1	6ES7 658-1CX17-2YA5	SOFTWARE SIMATIC PCS 7 VERSION CROSS MANAGER V7.1	
	1	6ES7 658-1FX08-2YA5	SOFTWARE SIMATIC PCS 7 VERSION TRAIL V8.0	
	1	6ES7 658-1DX08-2YB5	SOFTWARE SIMATIC PCS 7 IMPORT EXPORT ASSISTANT V8.0	
Operator System server				
1		6ES7660-2BA30-1DA0	SIMATIC PCS 7 INDUSTRIAL WORKSTATION IPC847C, CORE I7, OS SERVER, RAID1 (500GB INTERNAL), 8GB DDR3, BCE, PCS 7 V8.0 SP1, WIN SERVER 2008	
1		6ES7 658-2BA08-0YA0	SOFTWARE SIMATIC PCS 7 OS SOFTWARE SERVER V8.0 (PO 100)	¹⁾
Operator System client				
1		6ES7660-1CA18-1CA0	SIMATIC PCS 7 INDUSTRIAL WORKSTATION IPC647C, CORE I7, OS CLIENT, 500GB INTERNAL, 4GB DDR3, PCS 7 V8.0 SP1, WIN 7	
1		6ES7 658-2CX08-0YB5	SOFTWARE SIMATIC PCS 7 OS CLIENT V8.0	
	1	6ES7 652-0XD08-2YB5	SOFTWARE SIMATIC PCS 7 SFC VISUALIZATION V8.0	
Web Server				
1		6ES7660-2BA30-1DA0	SIMATIC PCS 7 INDUSTRIAL WORKSTATION IPC847C, CORE I7, OS SERVER, RAID1 (500GB INTERNAL), 8GB DDR3, BCE, PCS 7 V8.0 SP1, WIN SERVER 2008	
1		6ES7 658-2CX08-0YB5	SOFTWARE SIMATIC PCS 7 OS CLIENT V8.0	
1		6ES7 658-2GX08-2YB0	SOFTWARE SIMATIC PCS 7 WEB SERVER BASIC V8.0	
1		6ES7 658-2GF00-0XB0	SOFTWARE SIMATIC PCS 7 WEB SERVER (5 CLIENTS)	²⁾

Required	Optional	Product number	Product description	Note
Terminal servers				
1		6ES7660-2BA30-1DA0	SIMATIC PCS 7 INDUSTRIAL WORKSTATION IPC847C, CORE I7, OS SERVER, RAID1 (500GB INTERNAL), 8GB DDR3, BCE, PCS 7 V8.0 SP1, WIN SERVER 2008 INCL: 5 CAL	²⁾
Terminal bus				
1		6GK5 208-0BA10-2AA3	SIMATIC NET SCALANCE X208, MANAGED IE SWITCH, 8 X 10/100MBIT/S	³⁾
7		6XV1 870-3QH60	SIMATIC NET INDUSTRIAL ETHERNET TP CORD CABLE RJ45/RJ45, 6M	
System bus				
1		6GK5 208-0BA10-2AA3	SIMATIC NET SCALANCE X208, MANAGED IE SWITCH, 8 X 10/100MBIT/S	³⁾
4		6XV1 870-3QH60	SIMATIC NET INDUSTRIAL ETHERNET TP CORD CABLE RJ45/RJ45, 6M	
Automation system				
2		6ES7 654-6CN03-3BF0	SIMATIC PCS 7 SINGLE AS, CPU 410-5H, 1X DP-MODULE, 1x PROFINET-IO, SYSTEM EXPANSIONS CARD 1000 PO, AS RT PO 100, CP443-1IE, UR2 ALU RACK, 1 X UC 120/230V 10A POWER SUPPLY	⁴⁾

Note

Laptops that are used as terminal clients are not listed. Wireless LAN that is used for laptop connection is not listed.

- ¹⁾ The number of POs can be increased later on by means of extra volume licenses.
- ²⁾ The number of terminal clients can be increased by means of POWERPACKs.
- ³⁾ SCALANCE switch requires a 24VDC power supply (not listed).
- ⁴⁾ Please use the PCS 7 AS configurator, as the PCS 7 AS 410-5H is available in different versions, e.g. 24V DC or 110/230V AC.

6.9 Client/server with dual monitor

Figure 6-9

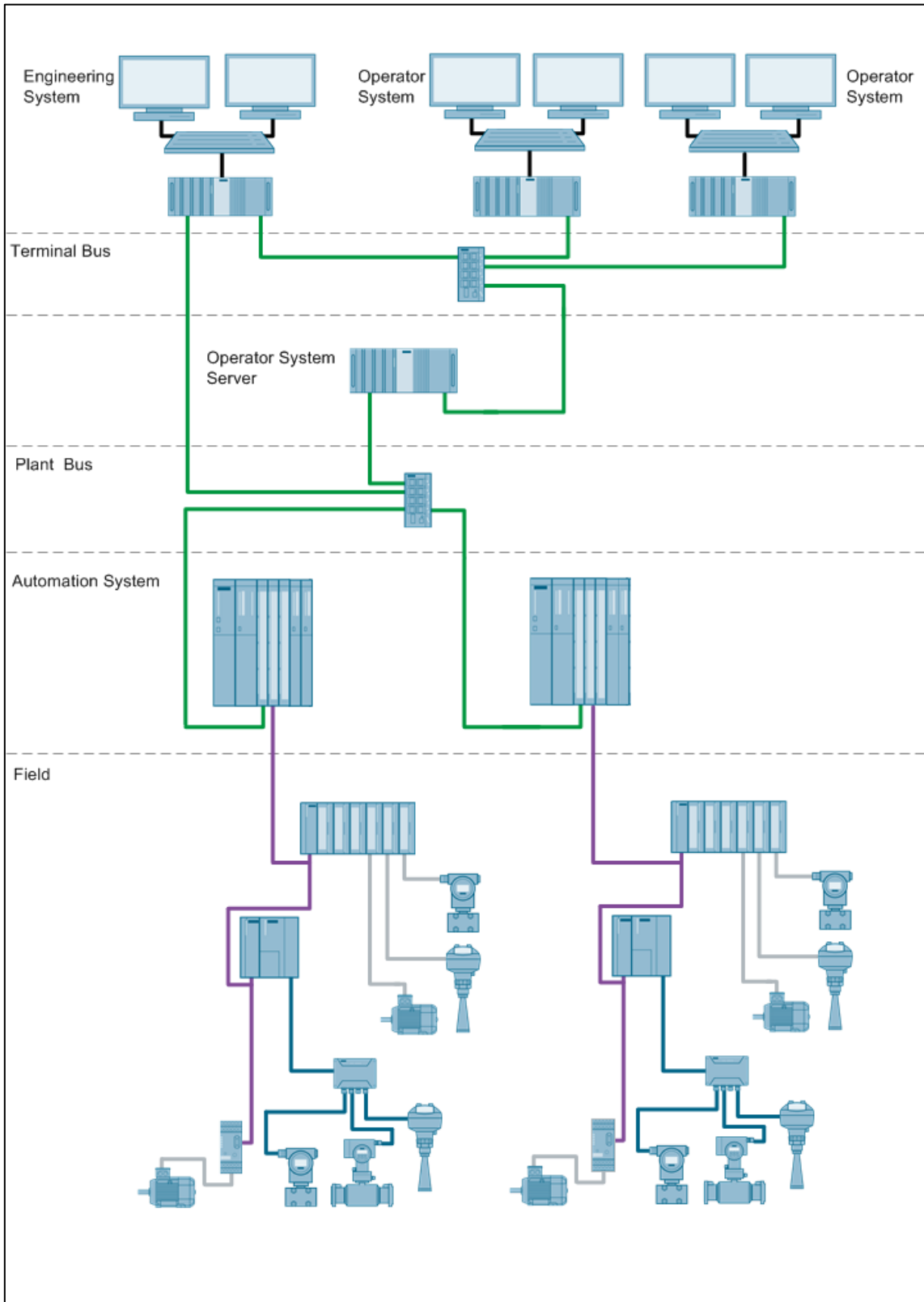

Bill of material for the client/server with dual monitor

Table 6–9

Required	Optional	Product number	Product description	Note
Engineering System				
1		6ES7660-2AA50-1CB0	SIMATIC PCS 7 INDUSTRIAL WORKSTATION IPC847C, CORE I7, ES/OS SINGLESTATION, RAID1 (500GB INTERNAL), 8GB DDR3, BCE, MULTI VGA 2-SCREEN CARD PCS 7 V8.0 SP1, WIN 7	¹⁾
1		6ES7 658-5AX08-0YA5	SOFTWARE SIMATIC PCS 7 AS/OS ENGINEERING V8.0	
	1	6ES7 658-1CX17-2YA5	SOFTWARE SIMATIC PCS 7 VERSION CROSS MANAGER V7.1	
	1	6ES7 658-1FX08-2YA5	SOFTWARE SIMATIC PCS 7 VERSION TRAIL V8.0	
	1	6ES7 658-1DX08-2YB5	SOFTWARE SIMATIC PCS 7 IMPORT EXPORT ASSISTANT V8.0	
Operator System server				
1		6ES7660-2BA30-1DA0	SIMATIC PCS 7 INDUSTRIAL WORKSTATION IPC847C, CORE I7, OS SERVER, RAID1 (500GB INTERNAL), 8GB DDR3, BCE, PCS 7 V8.0 SP1, WIN SERVER 2008	
1		6ES7 658-2BA08-0YA0	SOFTWARE SIMATIC PCS 7 OS SOFTWARE SERVER V8.0 (PO 100)	²⁾
Operator System client				
2		6ES7660-1CA18-1CB0	SIMATIC PCS 7 INDUSTRIAL WORKSTATION IPC647C, CORE I7, OS CLIENT, 500GB INTERNAL, 4GB DDR3 MULTI VGA 2-SCREEN CARD PCS 7 V8.0 SP1, WIN 7	¹⁾
2		6ES7 658-2CX08-0YB5	SOFTWARE SIMATIC PCS 7 OS CLIENT V8.0	
	2	6ES7 652-0XD08-2YB5	SOFTWARE SIMATIC PCS 7 SFC VISUALIZATION V8.0	

Required	Optional	Product number	Product description	Note
Terminal bus				
1		6GK5 208-0BA10-2AA3	SIMATIC NET SCALANCE X208, MANAGED IE SWITCH, 8 X 10/100MBIT/S	³⁾
4		6XV1 870-3QH60	SIMATIC NET INDUSTRIAL ETHERNET TP CORD CABLE RJ45/RJ45, 6M	
System bus				
1		6GK5 208-0BA10-2AA3	SIMATIC NET SCALANCE X208, MANAGED IE SWITCH, 8 X 10/100MBIT/S	³⁾
4		6XV1 870-3QH60	SIMATIC NET INDUSTRIAL ETHERNET TP CORD CABLE RJ45/RJ45, 6M	
Automation system				
2		6ES7 654-6CN03-3BF0	SIMATIC PCS 7 SINGLE AS, CPU 410-5H, 1X DP-MODULE, 1x PROFINET-IO, SYSTEM EXPANSIONS CARD 1000 PO, AS RT PO 100, CP443-1IE, UR2 ALU RACK, 1 X UC 120/230V 10A POWER SUPPLY	⁴⁾

Note

- ¹⁾ If quad Multi VGA is available, the number of monitors must be increased accordingly.
- ²⁾ The number of POs can be increased later on by means of extra volume licenses.
- ³⁾ SCALANCE switch requires a 24VDC power supply (not listed).
- ⁴⁾ Please use the PCS 7 AS configurator, as the PCS 7 AS 410-5H is available in different versions, e.g. 24V DC or 110/230V AC.

6.10 Client/server system with multi-user engineering

Figure 6-10

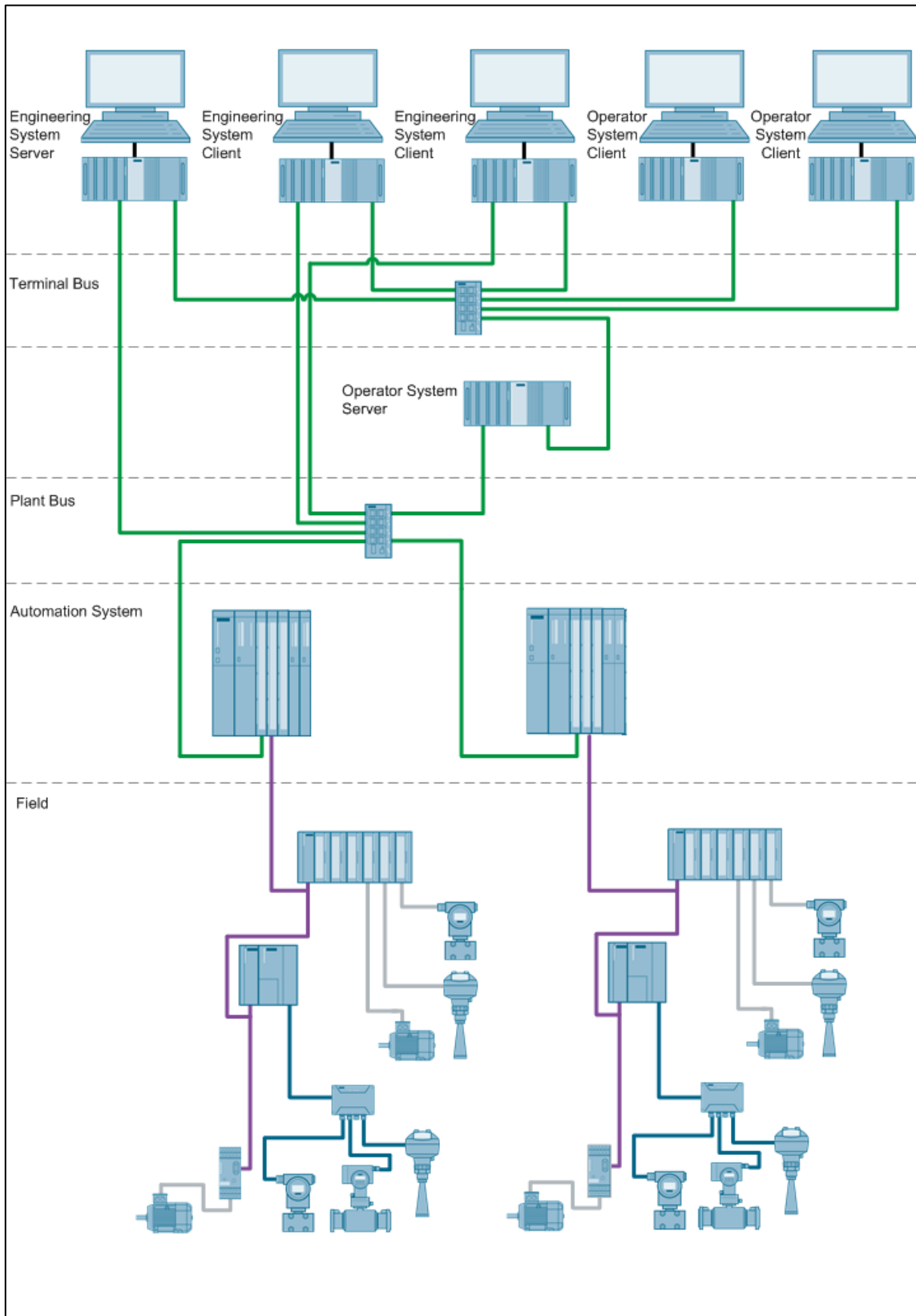

Bill of material for the client/server system with multi-user engineering

Table 6–10

Required	Optional	Product number	Product description	Note
Engineering System server				
1		6ES7660-2BA30-1DA0	SIMATIC PCS 7 INDUSTRIAL WORKSTATION IPC847C, CORE I7, OS SERVER, RAID1 (500GB INTERNAL), 8GB DDR3, BCE, PCS 7 V8.0 SP1, WIN SERVER 2008	
1		6ES7 658-5AX08-0YA5	SOFTWARE SIMATIC PCS 7 AS/OS ENGINEERING V8.0	1)
	1	6ES7 658-1CX17-2YA5	SOFTWARE SIMATIC PCS 7 VERSION CROSS MANAGER V7.1	
	1	6ES7 658-1FX08-2YA5	SOFTWARE SIMATIC PCS 7 VERSION TRAIL V8.0	
	1	6ES7 658-1DX08-2YB5	SOFTWARE SIMATIC PCS 7 IMPORT EXPORT ASSISTANT V8.0	
Engineering System client				
2		6ES7660-2AA30-1CA0	SIMATIC PCS 7 INDUSTRIAL WORKSTATION IPC847C, CORE I7, ES/OS SINGLESTATION, RAID1 (500GB INTERNAL), 8GB DDR3, BCE, PCS 7 V8.0 SP1, WIN 7	
2		6ES7658-1AF08-0YB5	SOFTWARE PCS 7 ENG V8.0 AS UNLIMITED	
Operator System server				
1		6ES7660-2BA30-1DA0	SIMATIC PCS 7 INDUSTRIAL WORKSTATION IPC847C, CORE I7, OS SERVER, RAID1 (500GB INTERNAL), 8GB DDR3, BCE, PCS 7 V8.0 SP1, WIN SERVER 2008	
1		6ES7 658-2BA08-0YA0	SOFTWARE SIMATIC PCS 7 OS SOFTWARE SERVER V8.0 (PO 100)	2)
Operator System client				
2		6ES7660-1CA18-1CA0	SIMATIC PCS 7 INDUSTRIAL WORKSTATION IPC647C, CORE I7, OS CLIENT, 500GB INTERNAL, 4GB DDR3, PCS 7 V8.0 SP1, WIN 7	
2		6ES7 658-2CX08-0YB5	SOFTWARE SIMATIC PCS 7 OS CLIENT V8.0	
	2	6ES7 652-0XD08-2YB5	SOFTWARE SIMATIC PCS 7 SFC VISUALIZATION V8.0	

Required	Optional	Product number	Product description	Note
Terminal bus				
1		6GK5 208-0BA10-2AA3	SIMATIC NET SCALANCE X208, MANAGED IE SWITCH, 8 X 10/100MBIT/S	³⁾
6		6XV1 870-3QH60	SIMATIC NET INDUSTRIAL ETHERNET TP CORD CABLE RJ45/RJ45, 6M	
System bus				
1		6GK5 208-0BA10-2AA3	SIMATIC NET SCALANCE X208, MANAGED IE SWITCH, 8 X 10/100MBIT/S	³⁾
6		6XV1 870-3QH60	SIMATIC NET INDUSTRIAL ETHERNET TP CORD CABLE RJ45/RJ45, 6M	
Automation system				
2		6ES7 654-6CN03-3BF0	SIMATIC PCS 7 SINGLE AS, CPU 410-5H, 1X DP-MODULE, 1x PROFINET-IO, SYSTEM EXPANSIONS CARD 1000 PO, AS RT PO 100, CP443-1IE, UR2 ALU RACK, 1 X UC 120/230V 10A POWER SUPPLY	⁴⁾

Note

- ¹⁾ Only the Engineering System server is equipped with the OS Engineering Toolset.
- ²⁾ The number of POs can be increased later on by means of extra volume licenses.
- ³⁾ SCALANCE switch requires a 24VDC power supply (not listed).
- ⁴⁾ Please use the PCS 7 AS configurator, as the PCS 7 AS 410-5H is available in different versions, e.g. 24V DC or 110/230V AC.

7 Multi-server

Multi-server system

In large systems, the multi-server architecture of SIMATIC PCS 7 enables the use of large distributed systems. In this case, several OS servers, single or redundant, are used to supply a large number of OS clients with real-time and historical values.

If needed and when there are no engineering tasks pending, the Engineering System can be used as an OS client.

Redundant bus

The connection availability between the OS servers and the AS as well as between the OS servers and OS clients can be increased with redundant interfaces and network components.

Note

An OS server supports up to 32 OS clients.

The number of OS clients in the system can be greater than 32, but each OS server supports up to 32 OS clients.

The maximum number of OS servers in a system is 12; an OS client can be connected to a maximum of 12 OS servers.

7.1 Multi-server single bus architecture

Figure 7-1

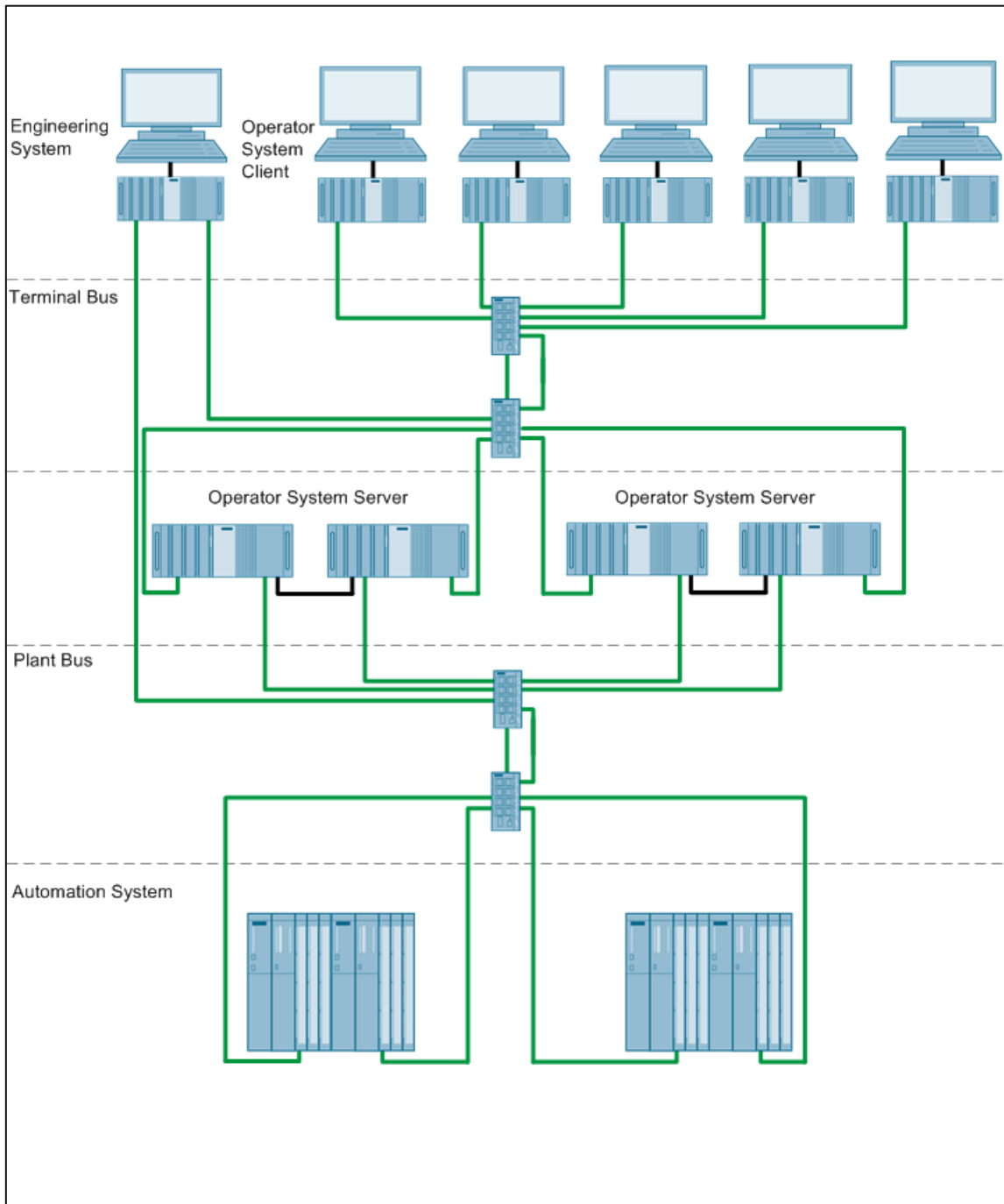

Bill of material for the multi-server single bus system

Table 7-1

Required	Optional	Product number	Product description	Note
Engineering System				
1		6ES7 660-2AA31-1CA0	SIMATIC PCS 7 INDUSTRIAL WORKSTATION IPC847C, CORE I7, ES/OS SINGLESTATION, RAID1 (500GB FRONT MOUNTED), 8GB DDR3, INDUSTRIAL ETHERNET (CP1623), PCS 7 V8.0 SP1, WIN 7	
1		6GK1 716-0HB08-1AC0	SIMATIC NET, S7-REDCONNECT POWERPACK	1)
1		6ES7 658-5AX08-0YA5	SOFTWARE SIMATIC PCS 7 AS/OS ENGINEERING V8.0	
	1	6ES7 658-1CX17-2YA5	SOFTWARE SIMATIC PCS 7 VERSION CROSS MANAGER V7.1	
	1	6ES7 658-1FX08-2YA5	SOFTWARE SIMATIC PCS 7 VERSION TRAIL V8.0	
	1	6ES7 658-1DX08-2YB5	SOFTWARE SIMATIC PCS 7 IMPORT EXPORT ASSISTANT V8.0	
Operator System server				
4		6ES7660-2BB31-1DA0	SIMATIC PCS 7 INDUSTRIAL WORKSTATION IPC847C, CORE I7, OS SERVER, RAID1 (500GB FRONT MOUNTED), 8GB DDR3, INDUSTRIAL ETHERNET (CP1623), PCS 7 V8.0 SP1, WIN SERVER 2008	
4		6GK1 716-0HB08-1AC0	SIMATIC NET, S7-REDCONNECT POWERPACK	1)
2		6ES7 652-3BA08-2YA0	SOFTWARE SIMATIC PCS 7 OS SERVER REDUNDANCY V8.0 (PO 100)	2) 5)
Operator System client				
5		6ES7660-1CA18-1CA0	SIMATIC PCS 7 INDUSTRIAL WORKSTATION IPC647C, CORE I7, OS CLIENT, 500GB INTERNAL, 4GB DDR3, PCS 7 V8.0 SP1, WIN 7	
5		6ES7 658-2CX08-0YB5	SOFTWARE SIMATIC PCS 7 OS CLIENT V8.0	
	5	6ES7 652-0XD08-2YB5	SOFTWARE SIMATIC PCS 7 SFC VISUALIZATION V8.0	

Required	Optional	Product number	Product description	Note
Terminal bus				
2		6GK5 216-0BA00-2AA3	SIMATIC NET SCALANCE X216, MANAGED IE SWITCH, 16 X 10/100MBIT/S	³⁾
12		6XV1 870-3QH60	SIMATIC NET INDUSTRIAL ETHERNET TP CORD CABLE RJ45/RJ45, 6M	
System bus				
2		6GK5 208-0BA10-2AA3	SIMATIC NET SCALANCE X208, MANAGED IE SWITCH, 8 X 10/100MBIT/S	³⁾
11		6XV1 870-3QH60	SIMATIC NET INDUSTRIAL ETHERNET TP CORD CABLE RJ45/RJ45, 6M	
Automation system				
2		6ES7 656-6CQ33-1CF0	SIMATIC PCS 7 REDUNDANCY AS, 2X CPU 410-5H, 2 DP-MODULE, 2X PROFINET-IO, SYSTEM EXPANSION CARD 2k+ PO, AS RT PO 100, 2 X 2 10M SYNC-MODULE AND 2 X 1M FO, 2 X CP443-1 IE/PN, 1 X UR2-H ALU RACK, 2 X UC 120/230V 10A RED. POWER SUPPLY	⁴⁾

Note

- ¹⁾ Required for redundant automation systems.
- ²⁾ The number of POs can be increased later on by means of extra volume licenses.
- ³⁾ SCALANCE switch requires a 24VDC power supply (not listed).
- ⁴⁾ Please use the PCS 7 AS configurator, as the PCS 7 AS 410-5H is available in different versions, e.g. 24V DC or 110/230V AC.

7.2 Redundant multi-server bus architecture

Figure 7-2

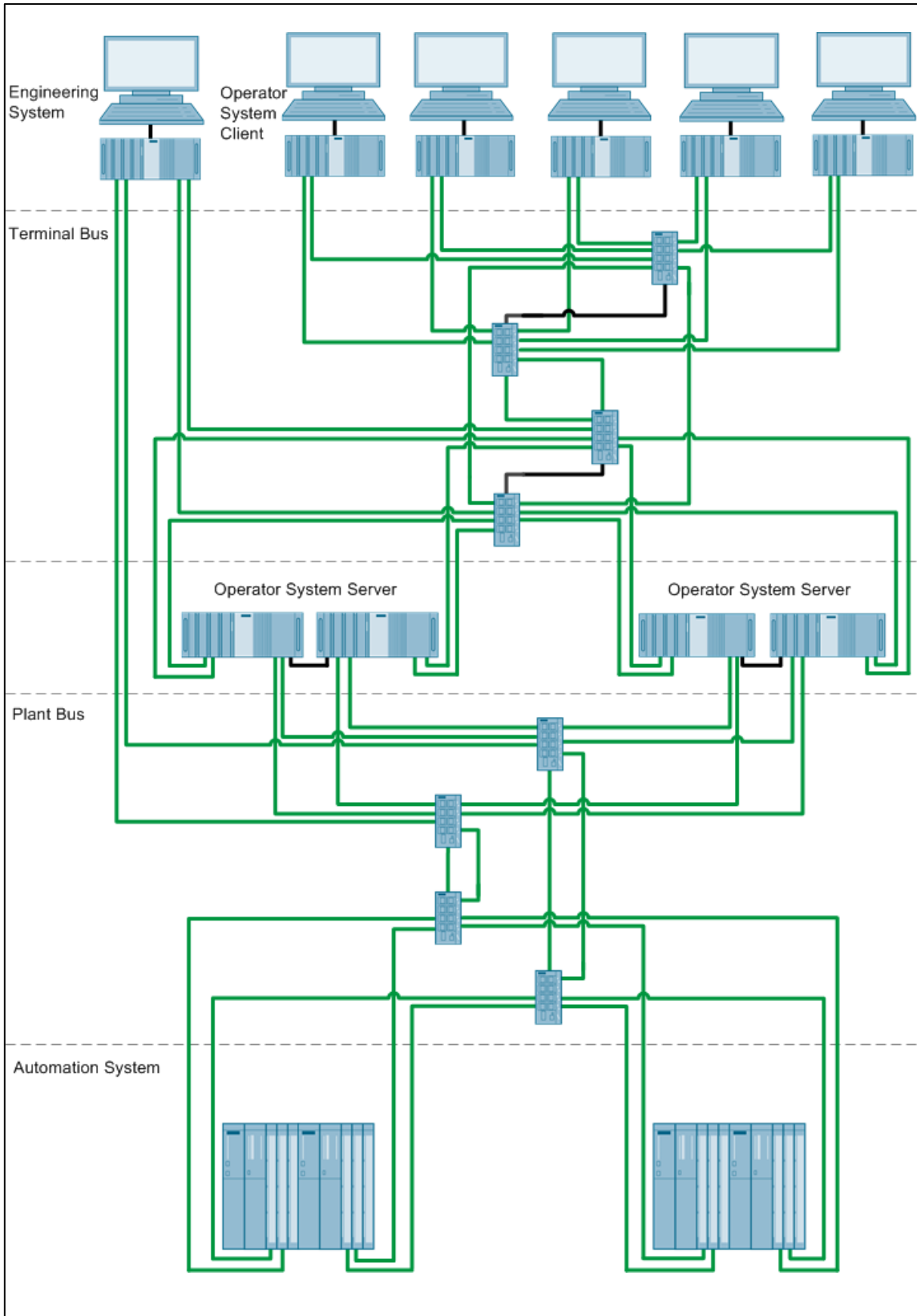

Copyright © Siemens AG 2013 All rights reserved

Bill of material for the redundant multi-server bus system

Table 7-2

Required	Optional	Product number	Product description	Note
Engineering System				
1		6ES7 660-2AA31-1CA0	SIMATIC PCS 7 INDUSTRIAL WORKSTATION IPC847C, CORE I7, ES/OS SINGLESTATION, RAID1 (500GB FRONT MOUNTED), 8GB DDR3, INDUSTRIAL ETHERNET (CP1623), PCS 7 V8.0 SP1, WIN 7	
1		6ES7 658-5AX08-0YA5	SOFTWARE SIMATIC PCS 7 AS/OS ENGINEERING V8.0	
1		6GK1 162-3AA00	SIMATIC NET COMMUNICATION PROCESSOR CP 1623 PCI EXPRESS	
1		6GK1 716-0HB08-1AC0	SIMATIC NET, S7-REDCONNECT POWERPACK	
1		6ES7 652-0XX01-1XF1	SIMATIC PCS 7 REDUNDANT TERMINAL BUS ADAPTER PACKAGE, 2 X INTEL PCI-E (EXPRESS) NETWORK CARD	
	1	6ES7 658-1CX17-2YA5	SOFTWARE SIMATIC PCS 7 VERSION CROSS MANAGER V7.1	
	1	6ES7 658-1FX08-2YA5	SOFTWARE SIMATIC PCS 7 VERSION TRAIL V8.0	
	1	6ES7 658-1DX08-2YB5	SOFTWARE SIMATIC PCS 7 IMPORT EXPORT ASSISTANT V8.0	
Operator System server				
4		6ES7660-2BB31-1DA0	6ES7660-2BB31-1DA0	
4		6GK1 162-3AA00	SIMATIC NET COMMUNICATION PROCESSOR CP 1623 PCI EXPRESS	
4		6GK1 716-0HB08-1AC0	SIMATIC NET, S7-REDCONNECT POWERPACK	
4		6ES7 652-0XX01-1XF1	SIMATIC PCS 7 REDUNDANT TERMINAL BUS ADAPTER PACKAGE, 2 X INTEL PCI-E (EXPRESS) NETWORK CARD	
2		6ES7 652-3BA08-2YA0	SOFTWARE SIMATIC PCS 7 OS SERVER REDUNDANCY V8.0 (PO 100)	1) 4)

Required	Optional	Product number	Product description	Note
Operator System client				
5		6ES7660-1CA18-1CA0	SIMATIC PCS 7 INDUSTRIAL WORKSTATION IPC647C, CORE I7, OS CLIENT, 500GB INTERNAL, 4GB DDR3, PCS 7 V8.0 SP1, WIN 7	
5		6ES7 652-0XX01-1XF1	SIMATIC PCS 7 REDUNDANT TERMINAL BUS ADAPTER PACKAGE, 2 X INTEL PCI-E (EXPRESS) NETWORK CARD	
5		6ES7 658-2CX08-0YB5	SOFTWARE SIMATIC PCS 7 OS CLIENT V8.0	
	5	6ES7 652-0XD08-2YB5	SOFTWARE SIMATIC PCS 7 SFC VISUALIZATION V8.0	
Terminal bus				
2		6GK5 216-0BA00-2AA3	SIMATIC NET SCALANCE X216, MANAGED IE SWITCH, 16 X 10/100MBIT/S	²⁾
4		6GK5 204-0BA00-2BA3	SCALANCE X204IRT, MANAGED IE IRT SWITCH, 4 X 10/100MBIT/S	
28		6XV1 870-3QH60	SIMATIC NET INDUSTRIAL ETHERNET TP CORD CABLE RJ45/RJ45, 6M	
System bus				
2		6GK5 216-0BA00-2AA3	SIMATIC NET SCALANCE X216, MANAGED IE SWITCH, 16 X 10/100MBIT/S	²⁾
16		6XV1 870-3QH60	SIMATIC NET INDUSTRIAL ETHERNET TP CORD CABLE RJ45/RJ45, 6M	
Automation system				
2		6ES7 656-6CQ34-1CF0	SIMATIC PCS 7 REDUNDANCY AS, 2X CPU 410-5H, 2 DP-MODULE, 2X PROFINET-IO, SYSTEM EXPANSION CARD 1600 PO, AS RT PO 100, 2 X 2 10M SYNC-MODULE AND 2 X 1M FO, 2 X 2 CP443-1 IE/PN, 1 X UR2-H ALU RACK, 2 X UC 120/230V 10A RED. POWER SUPPLY	³⁾

Note

- ¹⁾ The number of POs can be increased later on by means of extra volume licenses.
- ²⁾ SCALANCE switch requires a 24VDC power supply (not listed).
- ³⁾ Please use the PCS 7 AS configurator, as the PCS 7 AS 410-5H is available in different versions, e.g. 24V DC or 110/230V AC.⁴⁾ The redundant OS server is supplied with an RS-232 serial connection cable. If there is a long distance between the redundant systems, one can use an Ethernet connection as an alternative. This requires additional Ethernet network interface cards in the systems.

8 SIMATIC BATCH

SIMATIC BATCH

SIMATIC BATCH is the SIMATIC PCS 7 standard software for ISA-88 recipe management and batch management. SIMATIC BATCH is based on a scalable and modular software that can be used in all SIMATIC PCS 7 architectures.

SIMATIC BATCH uses a standard client / server architecture with clients for recipe editing and batch control. SIMATIC BATCH clients can be installed on SIMATIC PCS 7 single-user systems, server/client systems and PCs, on which no further SIMATIC PCS 7 software is available.

Starter System

The smallest system that supports SIMATIC BATCH is the single-user station architecture. All functions, engineering, operation and batch controls are installed on one single PC. Batch functions and operations are performed in the automation system.

Client/server

Mid-sized systems that support multiple users and require no redundancy are implemented as client/server systems. SIMATIC BATCH follows the Operator System architecture seamlessly by distributing the Batch server and client applications on the corresponding Operator System PCs.

Redundant client/server

When redundancy is required and the number of servers must be kept as small as possible, SIMATIC BATCH allows the operation of a redundant Batch server based on the redundant OS server PCs.

Redundant client/multi-server

When it comes to large, high-performance applications, the SIMATIC PCS 7 client/server architecture allows the distribution of applications over multiple PCs. In this case, the Batch server and the OS server run on two independent PCs. Each of them can be implemented redundantly, which achieves a very high availability. The OS client PCs can run the Batch client application and access both the OS server and the Batch server. If necessary, both the OS client and Batch client application can also run on separate PCs.

8.1 SIMATIC BATCH single-user station

Figure 8-1

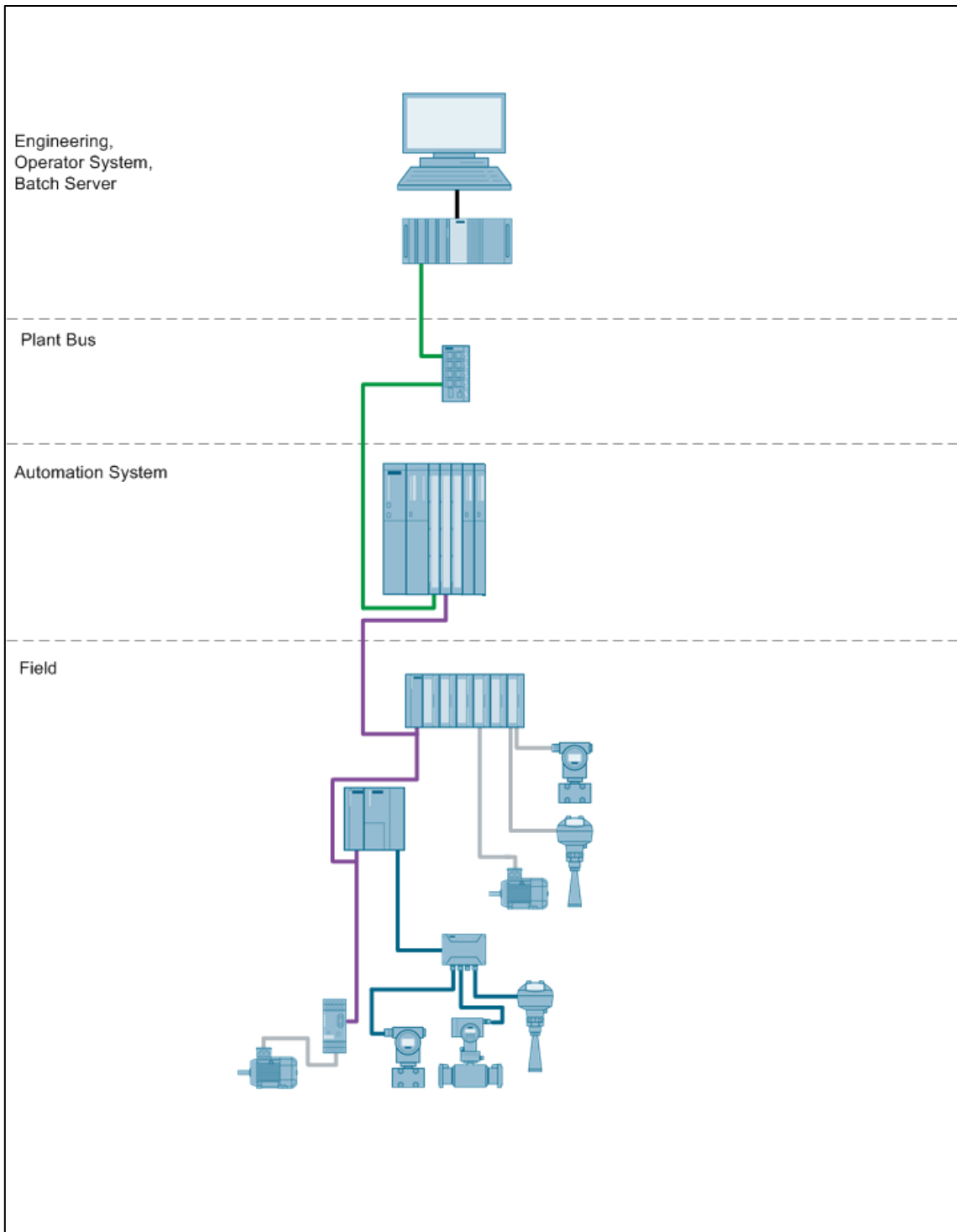

Bill of material for the SIMATIC BATCH single-user station architecture

Table 8–1

Required	Optional	Product number	Product description	Note
Engineering, Operator System and Batch server				
1		6ES7660-2AA30-1CA0	SIMATIC PCS 7 INDUSTRIAL WORKSTATION IPC847C, CORE I7, ES/OS SINGLESTATION, RAID1 (500GB INTERNAL), 8GB DDR3, BCE, PCS 7 V8.0 SP1, WIN 7	
1		6ES7 658-5AX08-0YA5	SOFTWARE SIMATIC PCS 7 AS/OS ENGINEERING V8.0	
1		6ES7 658-2AA08-0YA0	SOFTWARE SIMATIC PCS 7 OS SOFTWARE SINGLE STATION V8.0 (PO 100)	1)
	1	6ES7 652-0XD08-2YB5	SOFTWARE SIMATIC PCS 7 SFC VISUALIZATION V8.0	
	1	6ES7 658-1CX17-2YA5	SOFTWARE SIMATIC PCS 7 VERSION CROSS MANAGER V7.1	
	1	6ES7 658-1DX08-2YB5	SOFTWARE SIMATIC PCS 7 IMPORT EXPORT ASSISTANT V8.0	
	1	6ES7 658-1FX08-2YA5	SOFTWARE SIMATIC PCS 7 VERSION TRAIL V8.0	
1		6ES7 657-0UX08-0YB0	SOFTWARE SIMATIC BATCH SINGLE STATION PACKAGE V8.0	
1		6ES7 657-0XA00-0YB0	SOFTWARE SIMATIC BATCH (1 UNIT) V8.0	4)
System bus				
1		6GK5 208-0BA10-2AA3	SIMATIC NET SCALANCE X208, MANAGED IE SWITCH, 8 X 10/100MBIT/S	2)
2		6XV1 870-3QH60	SIMATIC NET INDUSTRIAL ETHERNET TP CORD CABLE RJ45/RJ45, 6M	
Automation system				
1		6ES7 654-6CL03-3BF0	SIMATIC PCS 7 SINGLE AS, CPU 410-5H, 1X DP-MODULE, 1x PROFINET-IO, SYSTEM EXPANSIONS CARD 500 PO, AS RT PO 100, CP443-1IE, UR2 ALU RACK, 1 X UC 120/230V 10A POWER SUPPLYSIMATIC	1) 3)

Note

- 1) The number of POs can be increased later on by means of extra volume licenses.
- 2) SCALANCE switch requires a 24VDC power supply (not listed).
- 3) Please use the PCS 7 AS configurator, as the PCS 7 AS 410-5H is available in different versions, e.g. 24V DC or 110/230V AC.
- 4) The number of batch units can be increased by means of cumulative batch unit licenses.

8.2 SIMATIC BATCH single-user system in an OS client/server architecture

Figure 8-2

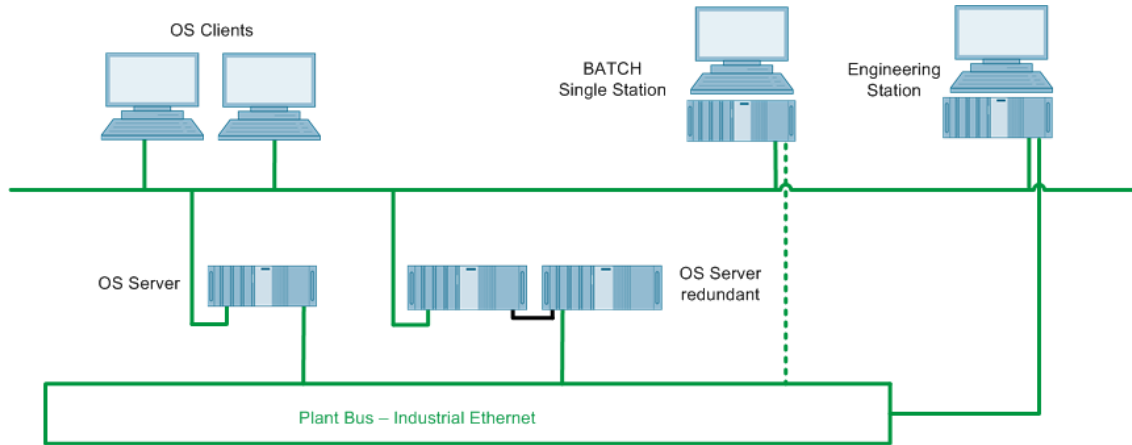

Bill of material for the SIMATIC BATCH client/server system

Table 8-2

Required	Optional	Product number	Product description	Note
Engineering System				
1		6ES7660-2AA30-1CA0	SIMATIC PCS 7 INDUSTRIAL WORKSTATION IPC847C, CORE I7, ES/OS SINGLESTATION, RAID1 (500GB INTERNAL), 8GB DDR3, BCE, PCS 7 V8.0 SP1, WIN 7	
1		6ES7 658-5AX08-0YA5	SOFTWARE SIMATIC PCS 7 AS/OS ENGINEERING V8.0	
	1	6ES7 658-1CX17-2YA5	SOFTWARE SIMATIC PCS 7 VERSION CROSS MANAGER V7.1	
	1	6ES7 658-1FX08-2YA5	SOFTWARE SIMATIC PCS 7 VERSION TRAIL V8.0	
	1	6ES7 658-1DX08-2YB5	SOFTWARE SIMATIC PCS 7 IMPORT EXPORT ASSISTANT V8.0	

8 SIMATIC BATCH

Required	Optional	Product number	Product description	Note
Operator System server				
1		6ES7660-2BA30-1DA0	SIMATIC PCS 7 INDUSTRIAL WORKSTATION IPC847C, CORE I7, OS SERVER, RAID1 (500GB INTERNAL), 8GB DDR3, BCE, PCS 7 V8.0 SP1, WIN SERVER 2008	
1		6ES7 658-2BA08-0YA0	SOFTWARE SIMATIC PCS 7 OS SOFTWARE SERVER V8.0 (PO 100)	¹⁾
Operator System client				
2		6ES7660-1CA18-1CA0	SIMATIC PCS 7 INDUSTRIAL WORKSTATION IPC647C, CORE I7, OS CLIENT, 500GB INTERNAL, 4GB DDR3, PCS 7 V8.0 SP1, WIN 7	
2		6ES7 658-2CX08-0YB5	SOFTWARE SIMATIC PCS 7 OS CLIENT V8.0	
	2	6ES7 652-0XD08-2YB5	SOFTWARE SIMATIC PCS 7 SFC VISUALIZATION V8.0	
Terminal bus				
1		6GK5 208-0BA10-2AA3	SIMATIC NET SCALANCE X208, MANAGED IE SWITCH, 8 X 10/100MBIT/S	²⁾
7		6XV1 870-3QH60	SIMATIC NET INDUSTRIAL ETHERNET TP CORD CABLE RJ45/RJ45, 6M	
System bus				
1		6GK5 208-0BA10-2AA3	SIMATIC NET SCALANCE X208, MANAGED IE SWITCH, 8 X 10/100MBIT/S	²⁾
5		6XV1 870-3QH60	SIMATIC NET INDUSTRIAL ETHERNET TP CORD CABLE RJ45/RJ45, 6M	
Automation system				
2		6ES7 654-6CN03-3BF0	SIMATIC PCS 7 SINGLE AS, CPU 410-5H, 1X DP-MODULE, 1x PROFINET-IO, SYSTEM EXPANSIONS CARD 1000 PO, AS RT PO 100, CP443-1IE, UR2 ALU RACK, 1 X UC 120/230V 10A POWER SUPPLY SIMATIC	³⁾

8 SIMATIC BATCH

Required	Optional	Product number	Product description	Note
BATCH single station				
1		6ES7660-2AA30-1CA0	SIMATIC PCS 7 INDUSTRIAL WORKSTATION IPC847C, CORE I7, ES/OS SINGLESTATION, RAID1 (500GB INTERNAL), 8GB DDR3, BCE, PCS 7 V8.0 SP1, WIN 7	
1		6ES7 657-0UX08-0YB0	SIMATIC BATCH Single Station Package V8.0 / including SIMATIC BATCH Recipe System	5)
1		6ES7 657-0XA00-0YB0	SOFTWARE SIMATIC BATCH (1 UNIT) V8.0	4)

Note

- 1) The number of POs can be increased later on by means of extra volume licenses.
- 2) SCALANCE switch requires a 24VDC power supply (not listed).
- 3) Please use the PCS 7 AS configurator, as the PCS 7 AS 410-5H is available in different versions, e.g. 24V DC or 110/230V AC.
- 4) The number of batch units can be increased by means of cumulative batch unit licenses.
- 5) The SIMATIC BATCH recipe system license is required on at least one client of a client/server system (on all clients that could be used to create and edit recipes).

8.3 SIMATIC BATCH client/server

Figure 8-3

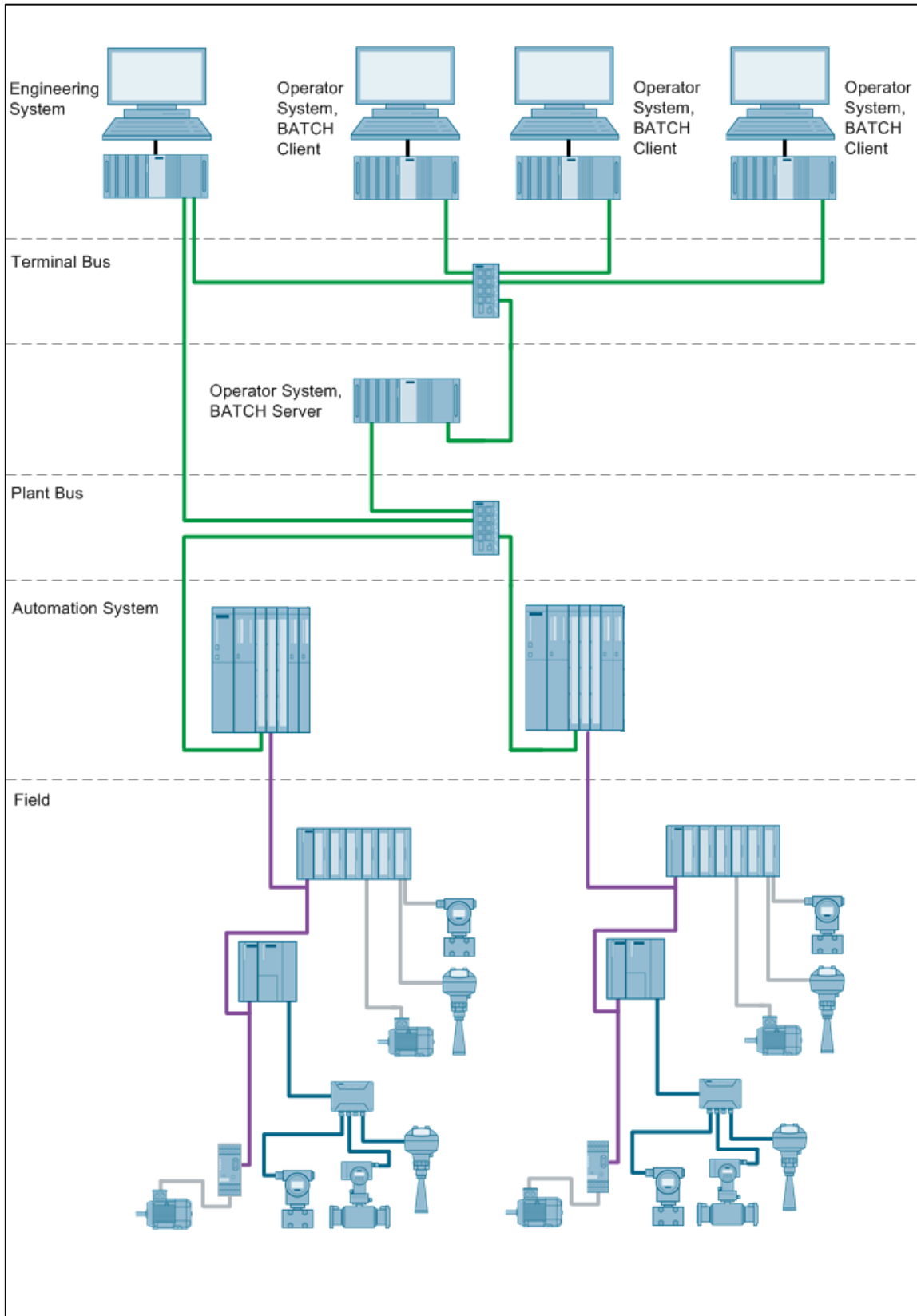

Copyright © Siemens AG 2013 All rights reserved

Bill of material for the SIMATIC BATCH client/server system

Table 8–3

Required	Optional	Product number	Product description	Note
Engineering System				
1		6ES7660-2AA30-1CA0	SIMATIC PCS 7 INDUSTRIAL WORKSTATION IPC847C, CORE I7, ES/OS SINGLESTATION, RAID1 (500GB INTERNAL), 8GB DDR3, BCE, PCS 7 V8.0 SP1, WIN 7	
1		6ES7 658-5AX08-0YA5	SOFTWARE SIMATIC PCS 7 AS/OS ENGINEERING V8.0	
	1	6ES7 658-1CX17-2YA5	SOFTWARE SIMATIC PCS 7 VERSION CROSS MANAGER V7.1	
	1	6ES7 658-1FX08-2YA5	SOFTWARE SIMATIC PCS 7 VERSION TRAIL V8.0	
	1	6ES7 658-1DX08-2YB5	SOFTWARE SIMATIC PCS 7 IMPORT EXPORT ASSISTANT V8.0	
Operator System, Batch server				
1		6ES7660-2BA30-1DA0	SIMATIC PCS 7 INDUSTRIAL WORKSTATION IPC847C, CORE I7, OS SERVER, RAID1 (500GB INTERNAL), 8GB DDR3, BCE, PCS 7 V8.0 SP1, WIN SERVER 2008	
1		6ES7 658-2BA08-0YA0	SOFTWARE SIMATIC PCS 7 OS SOFTWARE SERVER V8.0 (PO 100)	¹⁾
1		6ES7 657-0TX08-0YB0	SOFTWARE SIMATIC BATCH SERVER V8.0	
1		6ES7 657-0XB00-0YB0	SOFTWARE SIMATIC BATCH (10 UNITS) V8.0	⁴⁾
Operator System, Batch client				
3		6ES7660-1CA18-1CA0	SIMATIC PCS 7 INDUSTRIAL WORKSTATION IPC647C, CORE I7, OS CLIENT, 500GB INTERNAL, 4GB DDR3, PCS 7 V8.0 SP1, WIN 7	
3		6ES7 658-2CX08-0YB5	SOFTWARE SIMATIC PCS 7 OS CLIENT V8.0	
	3	6ES7 652-0XD08-2YB5	SOFTWARE SIMATIC PCS 7 SFC VISUALIZATION V8.0	
3		6ES7 657-0VX08-0YB5	SOFTWARE SIMATIC BATCH CLIENT V8.0	
1	2	6ES7 657-0AX08-0YB5	SOFTWARE SIMATIC BATCH RECIPE SYSTEM V8.0	⁵⁾

8 SIMATIC BATCH

Required	Optional	Product number	Product description	Note
Terminal bus				
1		6GK5 208-0BA10-2AA3	SIMATIC NET SCALANCE X208, MANAGED IE SWITCH, 8 X 10/100MBIT/S	²⁾
5		6XV1 870-3QH60	SIMATIC NET INDUSTRIAL ETHERNET TP CORD CABLE RJ45/RJ45, 6M	
System bus				
1		6GK5 208-0BA10-2AA3	SIMATIC NET SCALANCE X208, MANAGED IE SWITCH, 8 X 10/100MBIT/S	²⁾
4		6XV1 870-3QH60	SIMATIC NET INDUSTRIAL ETHERNET TP CORD CABLE RJ45/RJ45, 6M	
Automation system				
2		6ES7 654-6CN03-3BF0	SIMATIC PCS 7 SINGLE AS, CPU 410-5H, 1X DP-MODULE, 1x PROFINET-IO, SYSTEM EXPANSIONS CARD 1000 PO, AS RT PO 100, CP443-1IE, UR2 ALU RACK, 1 X UC 120/230V 10A POWER SUPPLY SIMATIC	³⁾

Note

- ¹⁾ The number of POs can be increased later on by means of extra volume licenses.
- ²⁾ SCALANCE switch requires a 24VDC power supply (not listed).
- ³⁾ Please use the PCS 7 AS configurator, as the PCS 7 AS 410-5H is available in different versions, e.g. 24V DC or 110/230V AC.
- ⁴⁾ The number of batch units can be increased by means of cumulative batch unit licenses.
- ⁵⁾ The SIMATIC BATCH recipe system license is required on at least one client of a client/server system (on all clients that could be used to create and edit recipes).

8.4 Separate SIMATIC BATCH Server

Figure 8-4

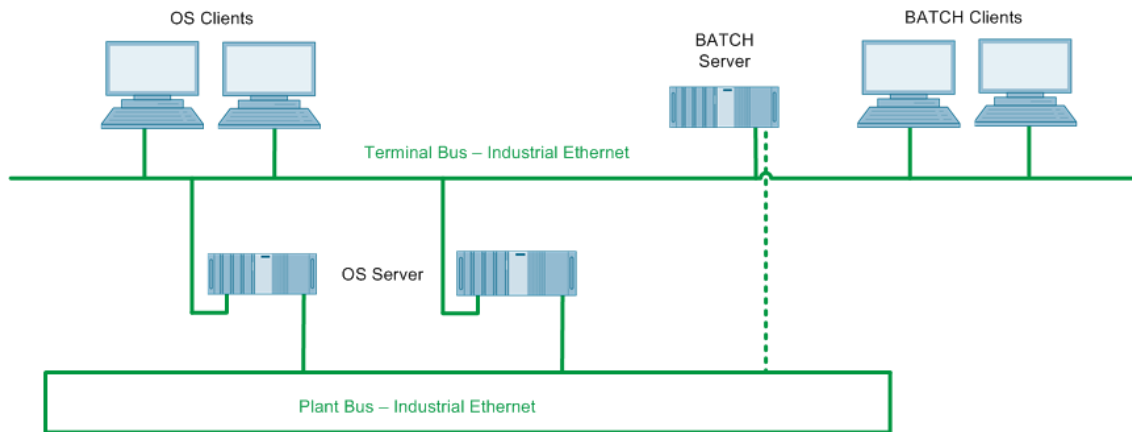

Bill of material for the SIMATIC BATCH client/server system

Table 8-4

Required	Optional	Product number	Product description	Note
Operator System, Batch server				
3		6ES7660-2BA30-1DA0	SIMATIC PCS 7 INDUSTRIAL WORKSTATION IPC847C, CORE I7, OS SERVER, RAID1 (500GB INTERNAL), 8GB DDR3, BCE, PCS 7 V8.0 SP1, WIN SERVER 2008	
2		6ES7 658-2BA08-0YA0	SOFTWARE SIMATIC PCS 7 OS SOFTWARE SERVER V8.0 (PO 100)	¹⁾
1		6ES7 657-0TX08-0YB0	SOFTWARE SIMATIC BATCH SERVER V8.0	
1		6ES7 657-0XB00-0YB0	SOFTWARE SIMATIC BATCH (10 UNITS) V8.0	⁴⁾

8 SIMATIC BATCH

Required	Optional	Product number	Product description	Note
Operator System, Batch client				
4		6ES7660-1CA18-1CA0	SIMATIC PCS 7 INDUSTRIAL WORKSTATION IPC547D, CORE I7, OS CLIENT, 500GB INTERNAL, 4GB DDR3, PCS 7 V8.0, WIN 7	
2		6ES7 658-2CX08-0YB5	SOFTWARE SIMATIC PCS 7 OS CLIENT V8.0	
	2	6ES7 652-0XD08-2YB5	SOFTWARE SIMATIC PCS 7 SFC VISUALIZATION V8.0	
2		6ES7 657-0VX08-0YB5	SOFTWARE SIMATIC BATCH CLIENT V8.0	
1	1	6ES7 657-0AX08-0YB5	SOFTWARE SIMATIC BATCH RECIPE SYSTEM V8.0	⁵⁾
Terminal bus				
1		6GK5 208-0BA10-2AA3	SIMATIC NET SCALANCE X208, MANAGED IE SWITCH, 8 X 10/100MBIT/S	²⁾
7		6XV1 870-3QH60	SIMATIC NET INDUSTRIAL ETHERNET TP CORD CABLE RJ45/RJ45, 6M	
System bus				
1		6GK5 208-0BA10-2AA3	SIMATIC NET SCALANCE X208, MANAGED IE SWITCH, 8 X 10/100MBIT/S	²⁾
3		6XV1 870-3QH60	SIMATIC NET INDUSTRIAL ETHERNET TP CORD CABLE RJ45/RJ45, 6M	
Automation system				
2		6ES7 654-6CN03-3BF0	SIMATIC PCS 7 SINGLE AS, CPU 410-5H, 1X DP-MODULE, 1x PROFINET-IO, SYSTEM EXPANSIONS CARD 1000 PO, AS RT PO 100, CP443-1IE, UR2 ALU RACK, 1 X UC 120/230V 10A POWER SUPPLY SIMATIC	³⁾

Note

- ¹⁾ The number of POs can be increased later on by means of extra volume licenses.
- ²⁾ SCALANCE switch requires a 24VDC power supply (not listed).
- ³⁾ Please use the PCS 7 AS configurator, as the PCS 7 AS 410-5H is available in different versions, e.g. 24V DC or 110/230V AC.
- ⁴⁾ The number of batch units can be increased by means of cumulative batch unit licenses.
- ⁵⁾ The SIMATIC BATCH recipe system license is required on at least one client of a client/server system (on all clients that could be used to create and edit recipes).

8.5 Redundant SIMATIC BATCH client/server architecture

Figure 8-5

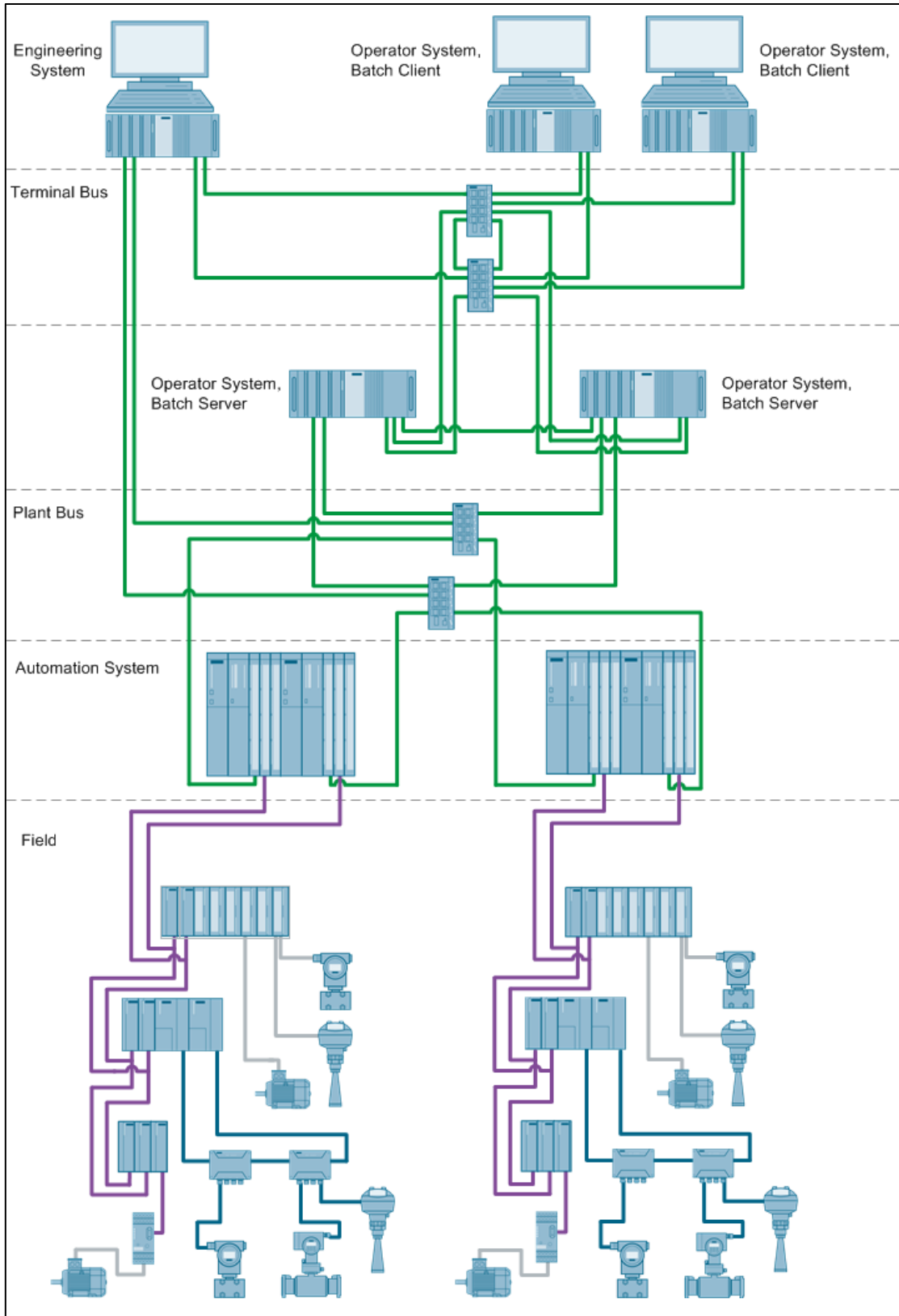

Bill of material for the redundant SIMATIC BATCH Client/server system

Table 8–5

Required	Optional	Product number	Product description	Note
Engineering System				
1		6ES7660-2BB31-1DA0	SIMATIC PCS 7 INDUSTRIAL WORKSTATION IPC847C, CORE I7, ES/OS SINGLESTATION, RAID1 (500GB FRONT MOUNTED), 8GB DDR3, INDUSTRIAL ETHERNET (CP1623), PCS 7 V8.0 SP1, WIN 7	
1		6ES7 658-5AX08-0YA5	SOFTWARE SIMATIC PCS 7 AS/OS ENGINEERING V8.0	
1		6GK1 162-3AA00	SIMATIC NET COMMUNICATION PROCESSOR CP 1623 PCI EXPRESS	1)
1		6GK1 716-0HB08-1AC0	SIMATIC NET, S7-REDCONNECT POWERPACK	4)
1		6ES7 652-0XX01-1XF1	SIMATIC PCS 7 REDUNDANT TERMINAL BUS ADAPTER PACKAGE, 2 X INTEL PCI-E (EXPRESS) NETWORK CARD	2)
	1	6ES7 658-1CX17-2YA5	SOFTWARE SIMATIC PCS 7 VERSION CROSS MANAGER V7.1	
	1	6ES7 658-1FX08-2YA5	SOFTWARE SIMATIC PCS 7 VERSION TRAIL V8.0	
	1	6ES7 658-1DX08-2YB5	SOFTWARE SIMATIC PCS 7 IMPORT EXPORT ASSISTANT V8.0	
Operator System, Batch server				
2		6ES7660-2BB31-1DA0	SIMATIC PCS 7 INDUSTRIAL WORKSTATION IPC847C, CORE I7, OS SERVER, RAID1 (500GB FRONT MOUNTED), 8GB DDR3, INDUSTRIAL ETHERNET (CP1623), PCS 7 V8.0 SP1, WIN SERVER 2008	
1		6ES7 652-3BA08-2YA0	SOFTWARE SIMATIC PCS 7 OS SERVER REDUNDANCY V8.0 (PO 100)	3)
2		6GK1 162-3AA00	SIMATIC NET COMMUNICATION PROCESSOR CP 1623 PCI EXPRESS	1)
2		6GK1 716-0HB08-1AC0	SIMATIC NET, S7-REDCONNECT POWERPACK	4)
2		6ES7 652-0XX01-1XF1	SIMATIC PCS 7 REDUNDANT TERMINAL BUS ADAPTER PACKAGE, 2 X INTEL PCI-E (EXPRESS) NETWORK CARD	2)
2		A5E02639550	DESKTOP ADAPTER NETWORK CARD	8)
1		6XV1 870-3RH60	SIMATIC NET INDUSTRIAL ETHERNET TP XP CORD RJ45/RJ45, 6M	
2		6ES7 657-0TX08-0YB0	SOFTWARE SIMATIC BATCH SERVER V8.0	
2		6ES7 657-0XB00-0YB0	SOFTWARE SIMATIC BATCH (10 UNITS) V8.0	7)

8 SIMATIC BATCH

Required	Optional	Product number	Product description	Note
Operator System, Batch client				
2		6ES7660-1CA18-1CA0	SIMATIC PCS 7 INDUSTRIAL WORKSTATION IPC647C, CORE I7, OS CLIENT, 500GB INTERNAL, 4GB DDR3, PCS 7 V8.0 SP1, WIN 7	
2		6ES7 652-0XX01-1XF1	SIMATIC PCS 7 REDUNDANT TERMINAL BUS ADAPTER PACKAGE, 2 X INTEL PCI-E (EXPRESS) NETWORK CARD	²⁾
2		6ES7 658-2CX08-0YB5	SOFTWARE SIMATIC PCS 7 OS CLIENT V8.0	
	2	6ES7 652-0XD08-2YB5	SOFTWARE SIMATIC PCS 7 SFC VISUALIZATION V8.0	
2		6ES7 657-0VX08-0YB5	SOFTWARE SIMATIC BATCH CLIENT V8.0	
1	1	6ES7 657-0AX08-0YB5	SOFTWARE SIMATIC BATCH RECIPE SYSTEM V8.0	⁹⁾
Terminal bus				
2		6GK5 208-0BA10-2AA3	SIMATIC NET SCALANCE X208, MANAGED IE SWITCH, 8 X 10/100MBIT/S	⁵⁾
12		6XV1 870-3QH60	SIMATIC NET INDUSTRIAL ETHERNET TP CORD CABLE RJ45/RJ45, 6M	
System bus				
2		6GK5 208-0BA10-2AA3	SIMATIC NET SCALANCE X208, MANAGED IE SWITCH, 8 X 10/100MBIT/S	⁵⁾
10		6XV1 870-3QH60	SIMATIC NET INDUSTRIAL ETHERNET TP CORD CABLE RJ45/RJ45, 6M	
Automation system				
2		6ES7 656-6CN33-1CF0	SIMATIC PCS 7 REDUNDANCY AS, 2X CPU 410-5H, 2 DP-MODULE, 2X PROFINET-IO, SYSTEM EXPANSION CARD 1000, AS RT PO 100, 2 X 2 10M SYNC-MODULE AND 2 X 1M FO, 2 X CP443-1 IE/PN, 1 X UR2-H ALU RACK, 2 X UC 120/230V 10A RED. POWER SUPPLY	⁶⁾

Note

- 1) Required in case a redundant system bus is chosen.
- 2) Required in case a redundant terminal bus is chosen.
- 3) The number of POs can be increased later on by means of extra volume licenses.
- 4) Required in case a redundant system bus or a redundant automation system is chosen.
- 5) SCALANCE switch requires a 24VDC power supply (not listed).
- 6) Please use the PCS 7 AS configurator, as the PCS 7 AS 410-5H is available in different versions, e.g. 24V DC or 110/230V AC.
- 7) The number of batch units can be increased by means of cumulative batch unit licenses.
- 8) Additional network cards are required for redundancy switching.
- 9) The SIMATIC BATCH recipe system license is required on at least one client of a client/server system (on all clients that should be used to create and edit recipes).

8.6 SIMATIC BATCH multi-server

Figure 8-6

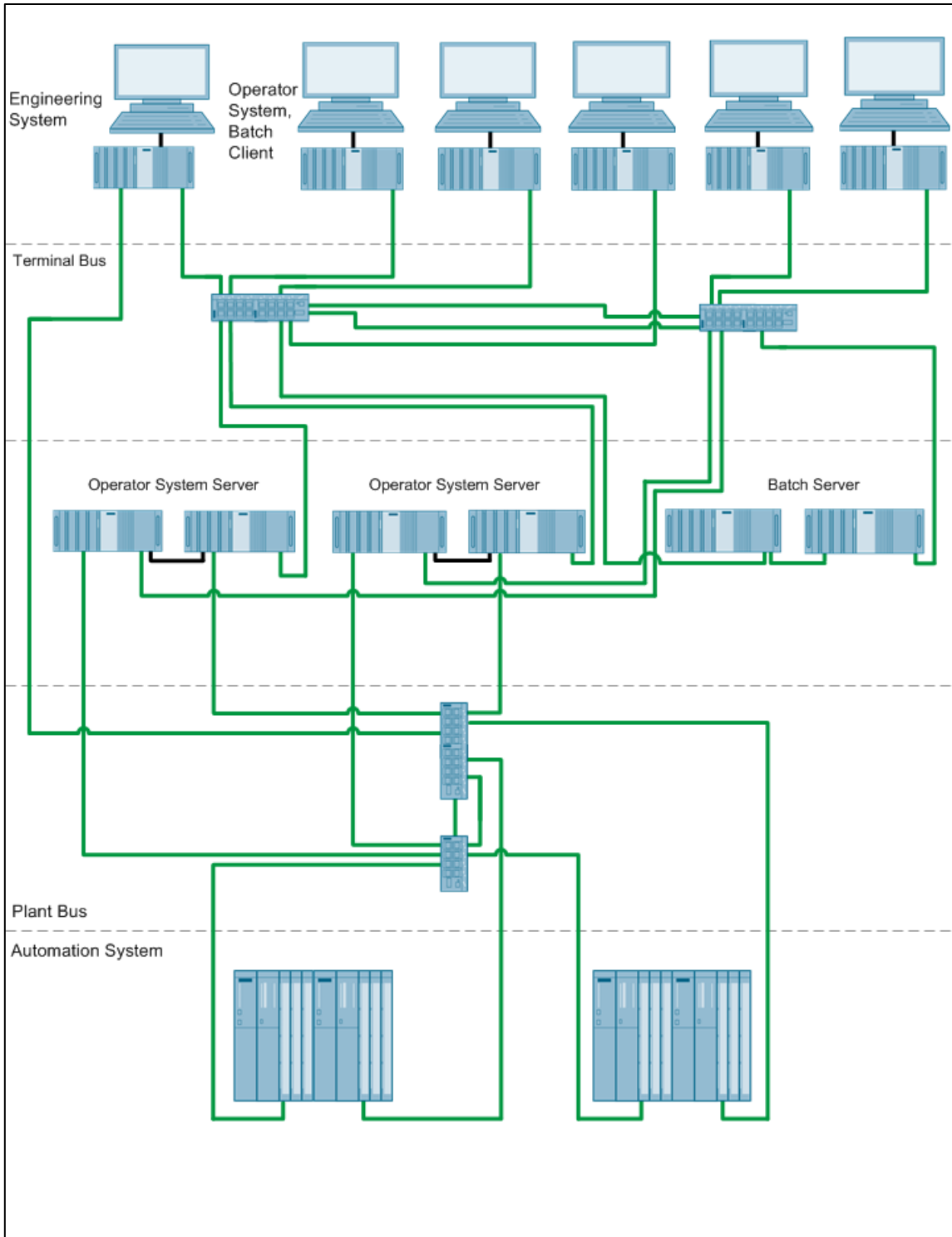

Copyright © Siemens AG 2013 All rights reserved

Bill of material for the SIMATIC BATCH multi-server

Table 8–6

Required	Optional	Product number	Product description	Note
Engineering System				
1		6ES7 660-2AA31-1CA0	SIMATIC PCS 7 INDUSTRIAL WORKSTATION IPC847C, CORE I7, ES/OS SINGLESTATION, RAID1 (500GB FRONT MOUNTED), 8GB DDR3, INDUSTRIAL ETHERNET (CP1623), PCS 7 V8.0 SP1, WIN 7	1)
1		6ES7 648-0CB00-0YA0	SIMATIC PC KEYBOARD GERMAN / INTERNATIONAL USB INTERFACE	
1		6GK1 716-0HB08-1AC0	SIMATIC NET, S7-REDCONNECT POWERPACK	1)
1		6ES7 658-5AX08-0YA5	SOFTWARE SIMATIC PCS 7 AS/OS ENGINEERING V8.0	
	1	6ES7 658-1CX17-2YA5	SOFTWARE SIMATIC PCS 7 VERSION CROSS MANAGER V7.1	
	1	6ES7 658-1FX08-2YA5	SOFTWARE SIMATIC PCS 7 VERSION TRAIL V8.0	
	1	6ES7 658-1DX08-2YB5	SOFTWARE SIMATIC PCS 7 IMPORT EXPORT ASSISTANT V8.0	
Operator System server				
4		6ES7660-2BB31-1DA0	SIMATIC PCS 7 INDUSTRIAL WORKSTATION IPC847C, CORE I7, OS SERVER, RAID1 (500GB FRONT MOUNTED), 8GB DDR3, INDUSTRIAL ETHERNET (CP1623), PCS 7 V8.0 SP1, WIN SERVER 2008	1)
4		6GK1 716-0HB08-1AC0	SIMATIC NET, S7-REDCONNECT POWERPACK	1)
2		6ES7 652-3BA08-2YA0	SOFTWARE SIMATIC PCS 7 OS SERVER REDUNDANCY V8.0 (PO 100)	2) 8)
Batch server				
2		6ES7660-2BA30-1DA0	SIMATIC PCS 7 INDUSTRIAL WORKSTATION IPC847C, CORE I7, OS SERVER, RAID1 (500GB INTERNAL), 8GB DDR3, BCE, PCS 7 V8.0 SP1, WIN SERVER 2008	6)
1		6XV1 870-3RH60	SIMATIC NET INDUSTRIAL ETHERNET TP XP CORD RJ45/RJ45, 6M	
2		6ES7 657-0TX08-0YB0	SOFTWARE SIMATIC BATCH SERVER V8.0	
2		6ES7 657-0XB00-0YB0	SOFTWARE SIMATIC BATCH (10 UNITS) V8.0	5)
Operator System, Batch client				
5		6ES7660-1CA18-1CA0	SIMATIC PCS 7 INDUSTRIAL WORKSTATION IPC647C, CORE I7, OS CLIENT, 500GB INTERNAL, 4GB DDR3, PCS 7 V8.0 SP1, WIN 7	
5		6ES7 658-2CX08-0YB5	SOFTWARE SIMATIC PCS 7 OS CLIENT V8.0	
	5	6ES7 652-0XD08-2YB5	SOFTWARE SIMATIC PCS 7 SFC VISUALIZATION V8.0	
2	3	6ES7 657-0VX08-0YB5	SOFTWARE SIMATIC BATCH CLIENT V8.0	
1	4	6ES7 657-0AX08-0YB5	SOFTWARE SIMATIC BATCH RECIPE SYSTEM V8.0	7)

Required	Optional	Product number	Product description	Note
Terminal bus				
2		6GK5 216-0BA00-2AA3	SIMATIC NET SCALANCE X216, MANAGED IE SWITCH, 16 X 10/100MBIT/S	³⁾
14		6XV1 870-3QH60	SIMATIC NET INDUSTRIAL ETHERNET TP CORD CABLE RJ45/RJ45, 6M	
System bus				
2		6GK5 208-0BA10-2AA3	SIMATIC NET SCALANCE X208, MANAGED IE SWITCH, 8 X 10/100MBIT/S	³⁾
10		6XV1 870-3QH60	SIMATIC NET INDUSTRIAL ETHERNET TP CORD CABLE RJ45/RJ45, 6M	
Automation system				
2		6ES7 656-6CQ33-1CF0	SIMATIC PCS 7 REDUNDANCY AS, 2X CPU 410-5H, 2 DP-MODULE, 2X PROFINET-IO, SYSTEM EXPANSION CARD 2k+ PO, AS RT PO 100, 2 X 2 10M SYNC-MODULE AND 2 X 1M FO, 2 X CP443-1 IE/PN, 1 X UR2-H ALU RACK, 2 X UC 120/230V 10A RED. POWER SUPPLY	⁴⁾

Note

- ¹⁾ Needed for a redundant automation system.
- ²⁾ The number of POs can be increased later on by means of POWERPACKs.
- ³⁾ SCALANCE switch requires a 24VDC power supply (not listed).
- ⁴⁾ Please use the PCS 7 AS configurator, as the PCS 7 AS 410-5H is available in different versions, e.g. 24V DC or 110/230V AC.
- ⁵⁾ The number of batch units can be increased by means of cumulative batch unit licenses.
- ⁶⁾ Second network card used for redundancy switching.
- ⁷⁾ The SIMATIC BATCH recipe system license is required on at least one client of a client/server system (on all clients that should be used to create and edit recipes).
- ⁸⁾ The redundant OS server is supplied with an RS-232 serial connection cable. If there is a long distance between the redundant systems, one can use an Ethernet connection as an alternative. This requires additional Ethernet network interface cards in the systems.

9 SIMATIC Route Control

SIMATIC Route Control

SIMATIC Route Control is an optional package of the SIMATIC PCS 7 process control system and is integrated into the PCS 7 engineering and runtime system. Route Control forms a system for the automatic or manual control of material transport (routes) in process plants. The system software Route Control (RC) has been available since PCS 7 V6.

Simple transport processes right up to comprehensive route combinations are possible during runtime. Plant operators only need to specify the source and target locations for the route request. Route Control allows users to determine, check, control and monitor transport routes and the route elements contained therein.

Starter System

The smallest system that supports all SIMATIC Route Control functions is the Single Station. Route Control engineering, server, client and the functionality of the automation system are all concentrated in one PC and run in parallel with the Operator System.

Client/server

Mid-sized systems that support multiple users and require no redundancy are implemented as client/server systems. SIMATIC Route Control scales seamlessly to the Operator System architecture by distributing the Route Control server and client applications on the corresponding Operator System PCs.

Redundant client/server

When redundancy is required and the number of servers must be kept as small as possible, SIMATIC Route Control allows the operation of a redundant Route Control server based on the redundant OS server.

Redundant client/multi-server

For large and high-performance applications, the SIMATIC PCS 7 client/server architecture allows the distribution of applications over multiple PCs. In this case, the Route Control server and the OS server run on two independent PCs. Each of them can be configured redundantly, which achieves a very high availability. The OS client PCs can access both the OS server and the Route Control server. If necessary, both the OS client and the Route Control client application can run on separate PCs.

9.1 SIMATIC Route Control single-user station

Figure 9-1

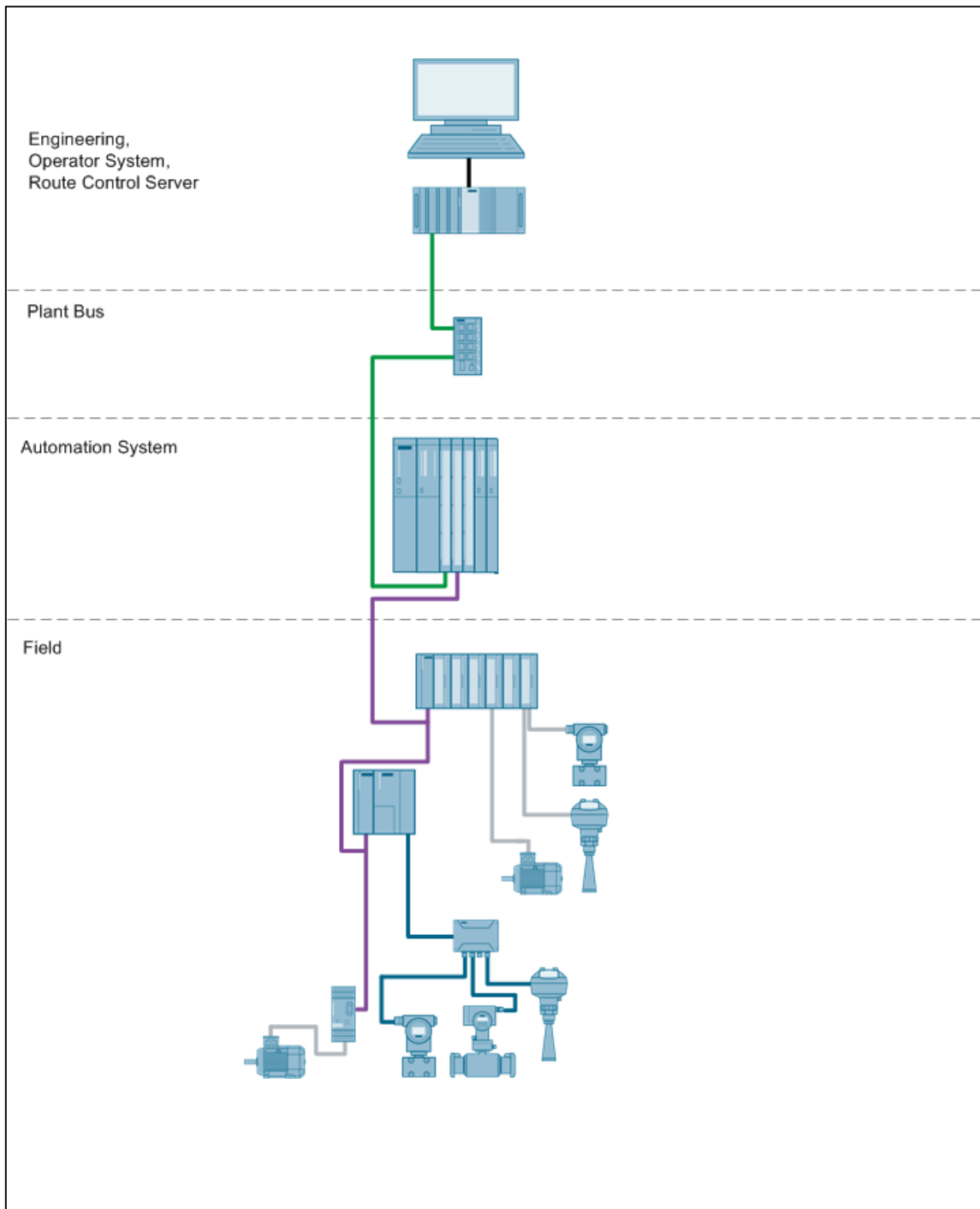

Bill of material for the SIMATIC Route Control single-user system

Table 9–1

Required	Optional	Product number	Product description	Note
Engineering, Operator System and Route Control server				
1		6ES7660-2AA30-1CA0	SIMATIC PCS 7 INDUSTRIAL WORKSTATION IPC847C, CORE I7, ES/OS SINGLESTATION, RAID1 (500GB INTERNAL), 8GB DDR3, BCE, PCS 7 V8.0 SP1, WIN 7	
1		6ES7 658-5AX08-0YA5	SOFTWARE SIMATIC PCS 7 AS/OS ENGINEERING V8.0	
1		6ES7 658-2AA08-0YA0	SOFTWARE SIMATIC PCS 7 OS SOFTWARE SINGLE STATION V8.0 (PO 100)	1)
	1	6ES7 652-0XD08-2YB5	SOFTWARE SIMATIC PCS 7 SFC VISUALIZATION V8.0	
	1	6ES7 658-1CX17-2YA5	SOFTWARE SIMATIC PCS 7 VERSION CROSS MANAGER V7.1	
	1	6ES7 658-1DX08-2YB5	SOFTWARE SIMATIC PCS 7 IMPORT EXPORT ASSISTANT V8.0	
	1	6ES7 658-1FX08-2YA5	SOFTWARE SIMATIC PCS 7 VERSION TRAIL V8.0	
1		6ES7 658-7DX08-0YB5	SOFTWARE SIMATIC ROUTE CONTROL ENGINEERING V8.0	
1		6ES7 658-7FX08-0YB0	SOFTWARE SIMATIC ROUTE CONTROL SERVER V8.0	
1		6ES7 658-7FF00-0XB0	SOFTWARE SIMATIC ROUTE CONTROL (10 ROUTES) V8.0	4)
1		6ES7 658-7EX08-0YB5	SOFTWARE SIMATIC ROUTE CONTROL CONTROL CENTER V8.0	

Required	Optional	Product number	Product description	Note
System bus				
1		6GK5 208-0BA10-2AA3	SIMATIC NET SCALANCE X208, MANAGED IE SWITCH, 8 X 10/100MBIT/S	2)
2		6XV1 870-3QH60	SIMATIC NET INDUSTRIAL ETHERNET TP CORD CABLE RJ45/RJ45, 6M	
Automation system				
1		6ES7 654-6CL03-3BF0	SIMATIC PCS 7 SINGLE AS, CPU 410-5H, 1X DP-MODULE, 1x PROFINET-IO, SYSTEM EXPANSIONS CARD 500 PO, AS RT PO 100, CP443-1IE, UR2 ALU RACK, 1 X UC 120/230V 10A POWER SUPPLYSIMATIC	1) 3)

Note

- 1) The number of POs can be increased later on by means of extra volume licenses.
- 2) SCALANCE switch requires a 24VDC power supply (not listed).
- 3) Please use the PCS 7 AS configurator, as the PCS 7 AS 410-5H is available in different versions, e.g. 24V DC or 110/230V AC.
- 4) At least one "SIMATIC Route Control Routes" license (for sets of 10/50) is required per project. The number of routes can be increased at a later stage with cumulative "SIMATIC Route Control Routes" licenses.

9.2 SIMATIC Route Control client/server architecture

Figure 9-2

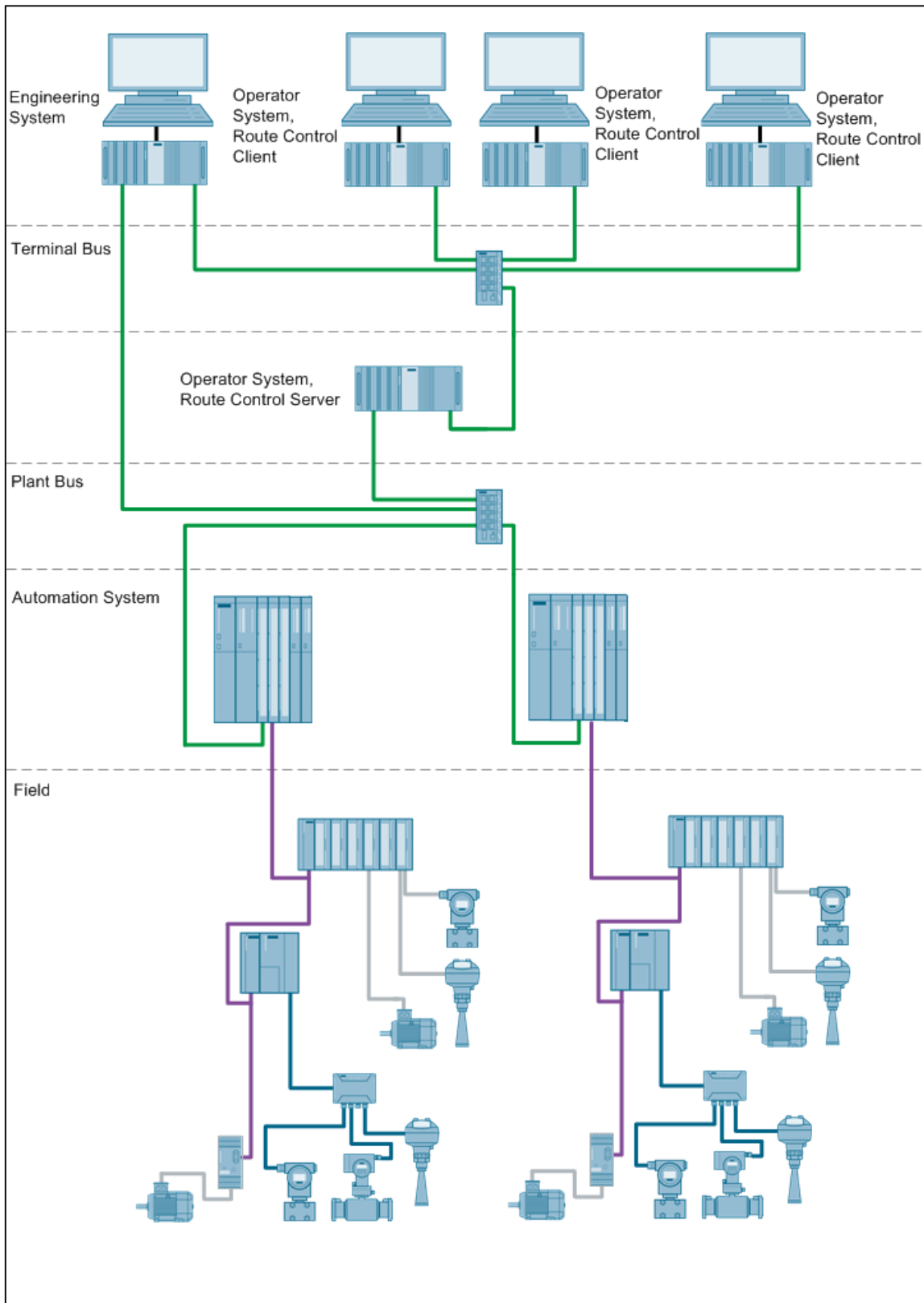

Copyright © Siemens AG 2013 All rights reserved

Bill of material for the SIMATIC Route Control client/server architecture

Table 9–2

Required	Optional	Product number	Product description	Note
Engineering System				
1		6ES7660-2AA30-1CA0	SIMATIC PCS 7 INDUSTRIAL WORKSTATION IPC847C, CORE I7, ES/OS SINGLESTATION, RAID1 (500GB INTERNAL), 8GB DDR3, BCE, PCS 7 V8.0 SP1, WIN 7	
1		6ES7 658-5AX08-0YA5	SOFTWARE SIMATIC PCS 7 AS/OS ENGINEERING V8.0	
1		6ES7 658-7DX08-0YB5	SOFTWARE SIMATIC ROUTE CONTROL ENGINEERING V8.0	
	1	6ES7 658-1CX17-2YA5	SOFTWARE SIMATIC PCS 7 VERSION CROSS MANAGER V7.1	
	1	6ES7 658-1FX08-2YA5	SOFTWARE SIMATIC PCS 7 VERSION TRAIL V8.0	
	1	6ES7 658-1DX08-2YB5	SOFTWARE SIMATIC PCS 7 IMPORT EXPORT ASSISTANT V8.0	
Operator System, Route Control server				
1		6ES7660-2BA30-1DA0	SIMATIC PCS 7 INDUSTRIAL WORKSTATION IPC847C, CORE I7, OS SERVER, RAID1 (500GB INTERNAL), 8GB DDR3, BCE, PCS 7 V8.0 SP1, WIN SERVER 2008	
1		6ES7 658-2BA08-0YA0	SOFTWARE SIMATIC PCS 7 OS SOFTWARE SERVER V8.0 (PO 100)	1)
1		6ES7 658-7FX08-0YB0	SOFTWARE SIMATIC ROUTE CONTROL SERVER V8.0	
1		6ES7 658-7FF00-0XB0	SOFTWARE SIMATIC ROUTE CONTROL (10 ROUTES) V8.0	4)
Operator System, Route Control client				
3		6ES7660-1CA18-1CA0	SIMATIC PCS 7 INDUSTRIAL WORKSTATION IPC647C, CORE I7, OS CLIENT, 500GB INTERNAL, 4GB DDR3, PCS 7 V8.0 SP1, WIN 7	
3		6ES7 658-2CX08-0YB5	SOFTWARE SIMATIC PCS 7 OS CLIENT V8.0	
	3	6ES7 652-0XD08-2YB5	SOFTWARE SIMATIC PCS 7 SFC VISUALIZATION V8.0	
3		6ES7 658-7EX08-0YB5	SOFTWARE SIMATIC ROUTE CONTROL CENTER V8.0	

Required	Optional	Product number	Product description	Note
Terminal bus				
1		6GK5 208-0BA10-2AA3	SIMATIC NET SCALANCE X208, MANAGED IE SWITCH, 8 X 10/100MBIT/S	²⁾
5		6XV1 870-3QH60	SIMATIC NET INDUSTRIAL ETHERNET TP CORD CABLE RJ45/RJ45, 6M	
System bus				
1		6GK5 208-0BA10-2AA3	SIMATIC NET SCALANCE X208, MANAGED IE SWITCH, 8 X 10/100MBIT/S	²⁾
4		6XV1 870-3QH60	SIMATIC NET INDUSTRIAL ETHERNET TP CORD CABLE RJ45/RJ45, 6M	
Automation system				
2		6ES7 654-6CN03-3BF0	SIMATIC PCS 7 SINGLE AS, CPU 410-5H, 1X DP-MODULE, 1x PROFINET-IO, SYSTEM EXPANSIONS CARD 1000 PO, AS RT PO 100, CP443-1IE, UR2 ALU RACK, 1 X UC 120/230V 10A POWER SUPPLY SIMATIC	³⁾

Note

- ¹⁾ The number of POs can be increased later on by means of extra volume licenses.
- ²⁾ SCALANCE switch requires a 24VDC power supply (not listed).
- ³⁾ Please use the PCS 7 AS configurator, as the PCS 7 AS 410-5H is available in different versions, e.g. 24V DC or 110/230V AC.
- ⁴⁾ At least one "SIMATIC Route Control Routes" license (for sets of 10/50) is required per project. The number of routes can be increased at a later stage with cumulative "SIMATIC Route Control Routes" licenses.

9.3 Redundant SIMATIC Route Control client/server architecture

Figure 9-3

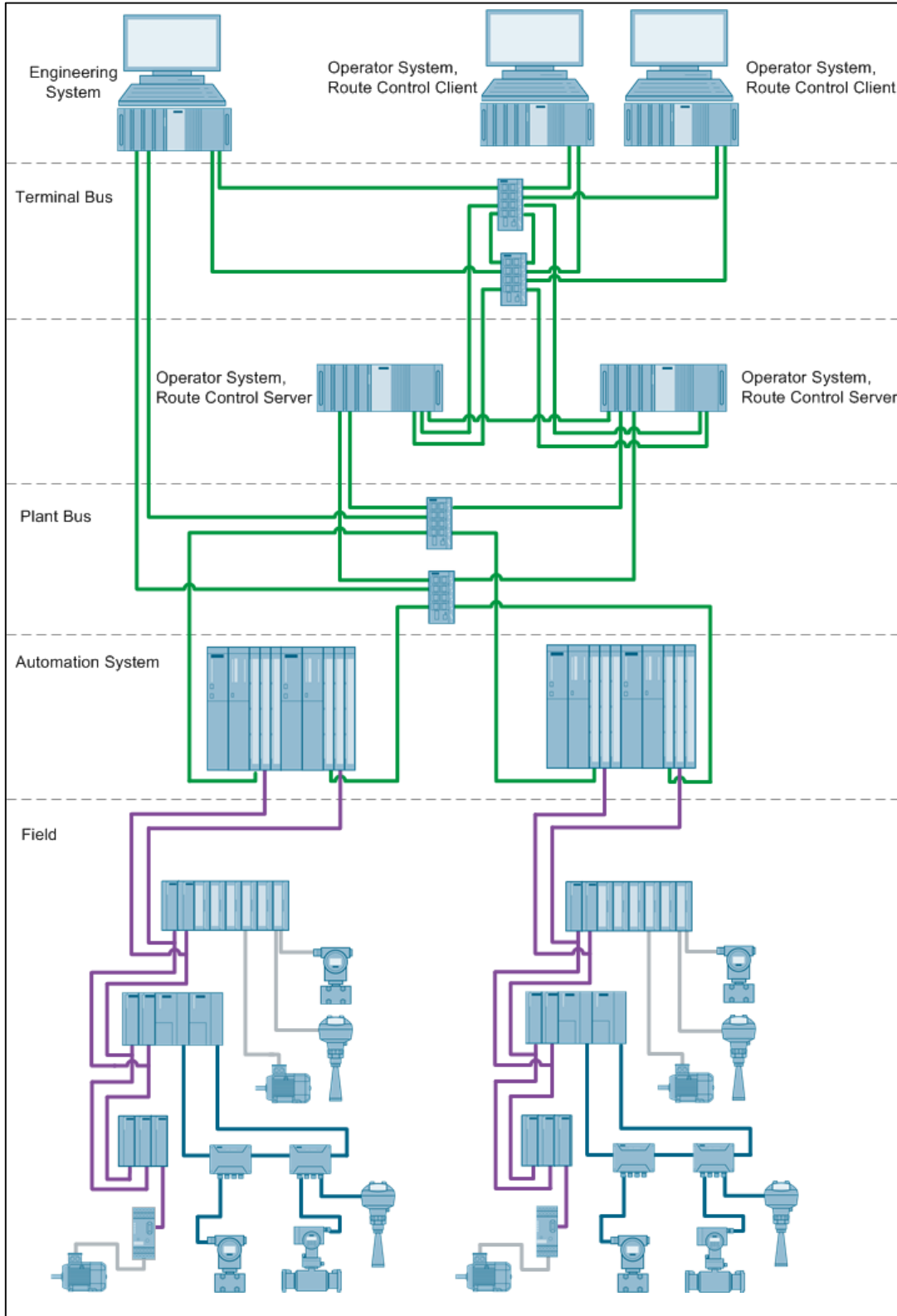

Copyright © Siemens AG 2013 All rights reserved

Bill of material for the redundant SIMATIC Route Control Client/server system

Table 9-3

Required	Optional	Product number	Product description	Note
Engineering System				
1		6ES7 660-2AA31-1CA0	SIMATIC PCS 7 INDUSTRIAL WORKSTATION IPC847C, CORE I7, ES/OS SINGLESTATION, RAID1 (500GB FRONT MOUNTED), 8GB DDR3, INDUSTRIAL ETHERNET (CP1623), PCS 7 V8.0 SP1, WIN 7	
1		6ES7 658-5AX08-0YA5	SOFTWARE SIMATIC PCS 7 AS/OS ENGINEERING V8.0	
1		6GK1 162-3AA00	SIMATIC NET COMMUNICATION PROCESSOR CP 1623 PCI EXPRESS	1)
1		6GK1 716-0HB08-1AC0	SIMATIC NET, S7-REDCONNECT POWERPACK	4)
1		6ES7 652-0XX01-1XF1	SIMATIC PCS 7 REDUNDANT TERMINAL BUS ADAPTER PACKAGE, 2 X INTEL PCI-E (EXPRESS) NETWORK CARD	2)
1		6ES7 658-7DX08-0YB5	SOFTWARE SIMATIC ROUTE CONTROL ENGINEERING V8.0	
	1	6ES7 658-1CX17-2YA5	SOFTWARE SIMATIC PCS 7 VERSION CROSS MANAGER V7.1	
	1	6ES7 658-1FX08-2YA5	SOFTWARE SIMATIC PCS 7 VERSION TRAIL V8.0	
	1	6ES7 658-1DX08-2YB5	SOFTWARE SIMATIC PCS 7 IMPORT EXPORT ASSISTANT V8.0	
Operator System, Route Control server				
2		6ES7660-2BB31-1DA0	SIMATIC PCS 7 INDUSTRIAL WORKSTATION IPC847C, CORE I7, OS SERVER, RAID1 (500GB FRONT MOUNTED), 8GB DDR3, INDUSTRIAL ETHERNET (CP1623), PCS 7 V8.0 SP1, WIN SERVER 2008	
1		6ES7 652-3BA08-2YA0	SOFTWARE SIMATIC PCS 7 OS SERVER REDUNDANCY V8.0 (PO 100)	3)
2		6GK1 162-3AA00	SIMATIC NET COMMUNICATION PROCESSOR CP 1623 PCI EXPRESS	1)
2		6GK1 716-0HB08-1AC0	SIMATIC NET, S7-REDCONNECT POWERPACK	4)
2		6ES7 652-0XX01-1XF1	SIMATIC PCS 7 REDUNDANT TERMINAL BUS ADAPTER PACKAGE, 2 X INTEL PCI-E (EXPRESS) NETWORK CARD	2)
2		A5E02639550	DESKTOP ADAPTER NETWORK CARD	8)
1		6XV1 870-3RH60	SIMATIC NET INDUSTRIAL ETHERNET TP XP CORD RJ45/RJ45, 6M	
2		6ES7 658-7FX08-0YB0	SOFTWARE SIMATIC ROUTE CONTROL SERVER V8.0	
1		6ES7 658-7FF00-0XB0	SOFTWARE SIMATIC ROUTE CONTROL (10 ROUTES) V8.0	7)

Required	Optional	Product number	Product description	Note
Operator System, Route Control client				
2		6ES7660-1CA18-1CA0	SIMATIC PCS 7 INDUSTRIAL WORKSTATION IPC647C, CORE I7, OS CLIENT, 500GB INTERNAL, 4GB DDR3, PCS 7 V8.0 SP1, WIN 7	
2		6ES7 652-0XX01-1XF1	SIMATIC PCS 7 REDUNDANT TERMINAL BUS ADAPTER PACKAGE, 2 X INTEL PCI-E (EXPRESS) NETWORK CARD	2)
2		6ES7 658-2CX08-0YB5	SOFTWARE SIMATIC PCS 7 OS CLIENT V8.0	
	2	6ES7 652-0XD08-2YB5	SOFTWARE SIMATIC PCS 7 SFC VISUALIZATION V8.0	
2		6ES7 658-7EX08-0YB5	SOFTWARE SIMATIC ROUTE CONTROL CONTROL CENTER V8.0	
Terminal bus				
2		6GK5 208-0BA10-2AA3	SIMATIC NET SCALANCE X208, MANAGED IE SWITCH, 8 X 10/100MBIT/S	5)
12		6XV1 870-3QH60	SIMATIC NET INDUSTRIAL ETHERNET TP CORD CABLE RJ45/RJ45, 6M	
System bus				
2		6GK5 208-0BA10-2AA3	SIMATIC NET SCALANCE X208, MANAGED IE SWITCH, 8 X 10/100MBIT/S	5)
12		6XV1 870-3QH60	SIMATIC NET INDUSTRIAL ETHERNET TP CORD CABLE RJ45/RJ45, 6M	
Automation system				
2		6ES7 656-6CN33-1CF0	SIMATIC PCS 7 REDUNDANCY AS, 2X CPU 410-5H, 2 DP-MODULE, 2X PROFINET-IO, SYSTEM EXPANSION CARD 1000, AS RT PO 100, 2 X 2 10M SYNC-MODULE AND 2 X 1M FO, 2 X CP443-1 IE/PN, 1 X UR2-H ALU RACK, 2 X UC 120/230V 10A RED. POWER SUPPLY	6)

Note

- 1) Required in case a redundant system bus is chosen.
- 2) Required in case a redundant terminal bus is chosen.
- 3) The number of POs can be increased later on by means of extra volume licenses.
- 4) Required in case a redundant system bus or a redundant automation system is chosen.
- 5) SCALANCE switch requires a 24VDC power supply (not listed).
- 6) Please use the PCS 7 AS configurator, as the PCS 7 AS 410-5H is available in different versions, e.g. 24V DC or 110/230V AC.
- 7) At least one "SIMATIC Route Control Routes" license (for sets of 10/50) is required per project. The number of routes can be increased at a later stage with cumulative "SIMATIC Route Control Routes" licenses.
- 8) Additional network cards are required for redundancy switching.

9.4 SIMATIC Route Control multi-server

Figure 9-4

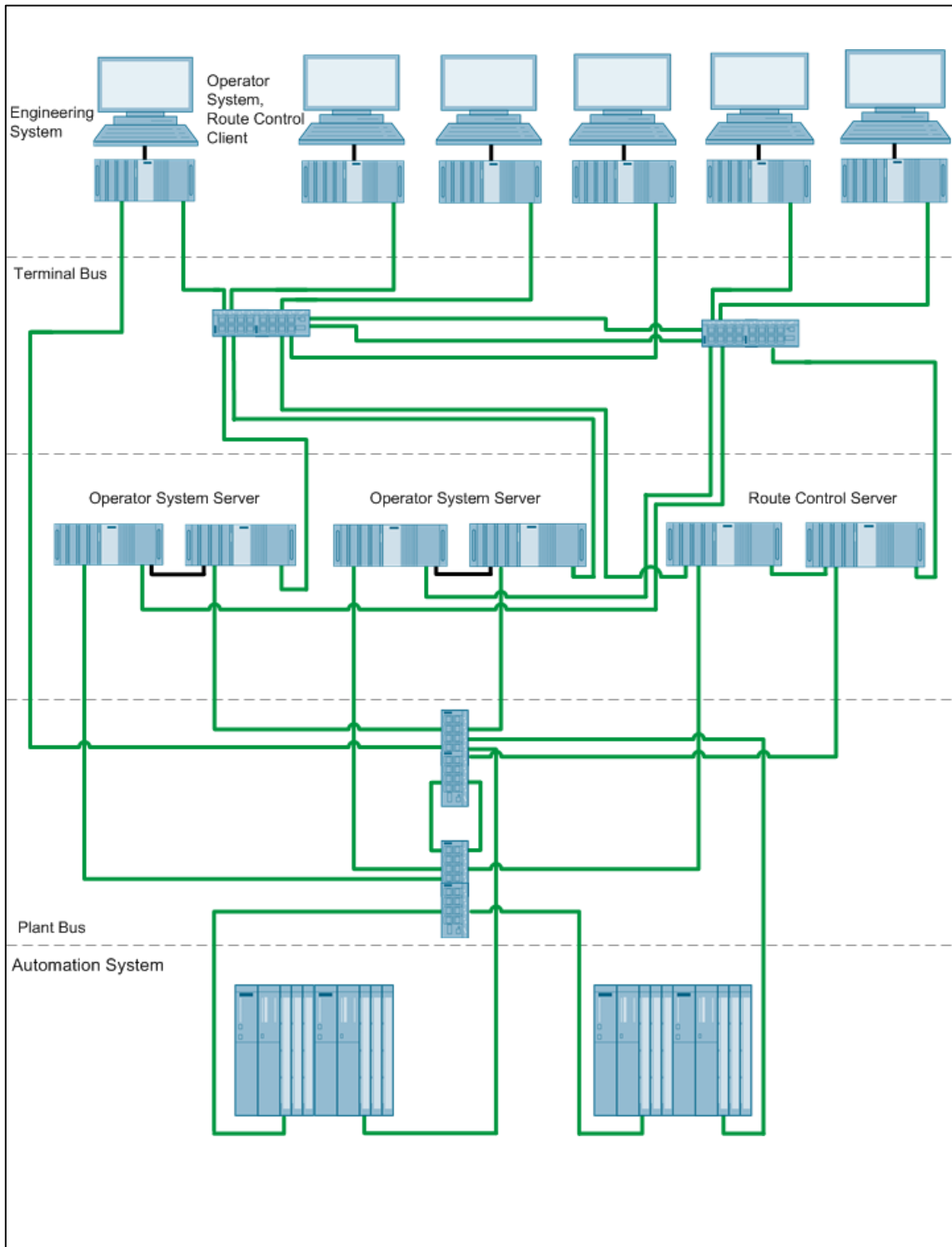

Copyright © Siemens AG 2013 All rights reserved

Bill of material for the Route Control multi-server

Table 9–4

Required	Optional	Product number	Product description	Note
Engineering System				
1		6ES7 660-3GG21-2CA0	SIMATIC PCS 7 INDUSTRIAL WORKSTATION IPC847C, CORE I7, ES/OS SINGLESTATION, RAID1 (500GB FRONT MOUNTED), 8GB DDR3, INDUSTRIAL ETHERNET (CP1623), PCS 7 V8.0 SP1, WIN 7	1)
1		6GK1 716-0HB08-1AC0	SIMATIC NET, S7-REDCONNECT POWERPACK	1)
1		6ES7 658-5AX08-0YA5	SOFTWARE SIMATIC PCS 7 AS/OS ENGINEERING V8.0	
1		6ES7 658-7DX08-0YB5	SOFTWARE SIMATIC ROUTE CONTROL ENGINEERING V8.0	
	1	6ES7 658-1CX17-2YA5	SOFTWARE SIMATIC PCS 7 VERSION CROSS MANAGER V7.1	
	1	6ES7 658-1FX08-2YA5	SOFTWARE SIMATIC PCS 7 VERSION TRAIL V8.0	
	1	6ES7 658-1DX08-2YB5	SOFTWARE SIMATIC PCS 7 IMPORT EXPORT ASSISTANT V8.0	
Operator System server				
4		6ES7660-2BB31-1DA0	SIMATIC PCS 7 INDUSTRIAL WORKSTATION IPC847C, CORE I7, OS SERVER, RAID1 (500GB FRONT MOUNTED), 8GB DDR3, INDUSTRIAL ETHERNET (CP1623), PCS 7 V8.0 SP1, WIN SERVER 2008	1)
4		6GK1 716-0HB08-1AC0	SIMATIC NET, S7-REDCONNECT POWERPACK	1)
2		6ES7 652-3BA08-2YA0	SOFTWARE SIMATIC PCS 7 OS SERVER REDUNDANCY V8.0 (PO 100)	2) 7)
Route Control Server				
2		6ES7660-2BB31-1DA0	SIMATIC PCS 7 INDUSTRIAL WORKSTATION IPC847C, CORE I7, OS SERVER, RAID1 (500GB FRONT MOUNTED), 8GB DDR3, INDUSTRIAL ETHERNET (CP1623), PCS 7 V8.0 SP1, WIN SERVER 2008	
2		A5E02639550	DESKTOP ADAPTER NETWORK CARD	6)
1		6XV1 870-3RH60	SIMATIC NET INDUSTRIAL ETHERNET TP XP CORD RJ45/RJ45, 6M	
2		6GK1 716-0HB08-1AC0	SIMATIC NET, S7-REDCONNECT POWERPACK	1)
2		6ES7 658-7FX08-0YB0	SOFTWARE SIMATIC ROUTE CONTROL SERVER V8.0	
1		6ES7 658-7FF00-0XB0	SOFTWARE SIMATIC ROUTE CONTROL (10 ROUTES) V8.0	5)

Required	Optional	Product number	Product description	Note
Operator System, Route Control client				
5		6ES7660-1CA18-1CA0	SIMATIC PCS 7 INDUSTRIAL WORKSTATION IPC647C, CORE I7, OS CLIENT, 500GB INTERNAL, 4GB DDR3, PCS 7 V8.0 SP1, WIN 7	
5		6ES7 658-2CX08-0YB5	SOFTWARE SIMATIC PCS 7 OS CLIENT V8.0	
	5	6ES7 652-0XD08-2YB5	SOFTWARE SIMATIC PCS 7 SFC VISUALIZATION V8.0	
5		6ES7 658-7EX08-0YB5	SOFTWARE SIMATIC ROUTE CONTROL CONTROL CENTER V8.0	
Terminal bus				
2		6GK5 216-0BA00-2AA3	SIMATIC NET SCALANCE X216, MANAGED IE SWITCH, 16 X 10/100MBIT/S	³⁾
14		6XV1 870-3QH60	SIMATIC NET INDUSTRIAL ETHERNET TP CORD CABLE RJ45/RJ45, 6M	
System bus				
2		6GK5 208-0BA10-2AA3	SIMATIC NET SCALANCE X208, MANAGED IE SWITCH, 8 X 10/100MBIT/S	³⁾
13		6XV1 870-3QH60	SIMATIC NET INDUSTRIAL ETHERNET TP CORD CABLE RJ45/RJ45, 6M	
Automation system				
2		6ES7 656-6CQ33-1CF0	SIMATIC PCS 7 REDUNDANCY AS, 2X CPU 410-5H, 2 DP-MODULE, 2X PROFINET-IO, SYSTEM EXPANSION CARD 2k+, AS RT PO 100, 2 X 2 10M SYNC-MODULE AND 2 X 1M FO, 2 X CP443-1 IE/PN, 1 X UR2-H ALU RACK, 2 X UC 120/230V 10A RED. POWER SUPPLY	⁴⁾

Note

- ¹⁾ Required for a redundant automation system.
- ²⁾ The number of POs can be increased later on by means of extra volume licenses.
- ³⁾ SCALANCE switch requires a 24VDC power supply (not listed).
- ⁴⁾ Please use the PCS 7 AS configurator, as the PCS 7 AS 410-5H is available in different versions, e.g. 24V DC or 110/230V AC.
- ⁵⁾ At least one "SIMATIC Route Control Routes" license (for sets of 10/50) is required per project. The number of routes can be increased at a later stage with cumulative "SIMATIC Route Control Routes" licenses.
- ⁶⁾ Additional network cards are required for redundancy switching.
- ⁷⁾ The redundant OS server is supplied with an RS-232 serial connection cable. If there is a long distance between the redundant systems, one can use an Ethernet connection as an alternative. This requires additional Ethernet network interface cards in the systems.

10 SIMATIC Route Control and SIMATIC BATCH

SIMATIC Route Control and SIMATIC BATCH

For batch applications requiring a transparent material transport between sub-systems, SIMATIC PCS 7 supports the integration of SIMATIC BATCH and SIMATIC Route Control in a single system. The ISA-88-based recipe management and batch processing software SIMATIC BATCH binds seamlessly with Route Control and allows material transport to be controlled via the recipe functions in the control recipe. Both SIMATIC BATCH and Route Control can be used for systems that range from starter size up to distributed client/server architectures.

Starter System

The smallest system is the single-user station architecture in which all functions, engineering, operation, batch control and path control are installed on a single PC. Batch functions and operations as well as material transport are performed in the automation system.

Client/server

Mid-sized systems that support multiple users and require no redundancy are implemented as client/server systems. SIMATIC BATCH and SIMATIC Route Control use the OS architecture by utilizing the batch and Route Control server/client applications on the corresponding OS PCs.

Redundant client/server

When redundancy is required and the number of servers must be kept as small as possible, SIMATIC BATCH and SIMATIC Route Control can be used on the basis of redundant OS servers (a combination of three redundant functions and two servers).

Redundant client/multi-server

When it comes to large, high-performance applications, the SIMATIC PCS 7 client/server architecture allows the distribution of applications over multiple PCs. In this case, the Batch server, Route Control server and OS server run on two or three independent PCs. Each of them can be configured redundantly, which achieves a very high availability. The OS client PCs can run the batch and Route Control client applications and access both the OS server and the batch and Route Control server. If necessary, both the OS client and Route Control and Batch client application can also run on separate PCs.

10.1 SIMATIC Route Control and SIMATIC BATCH single-user station

Figure 10-1

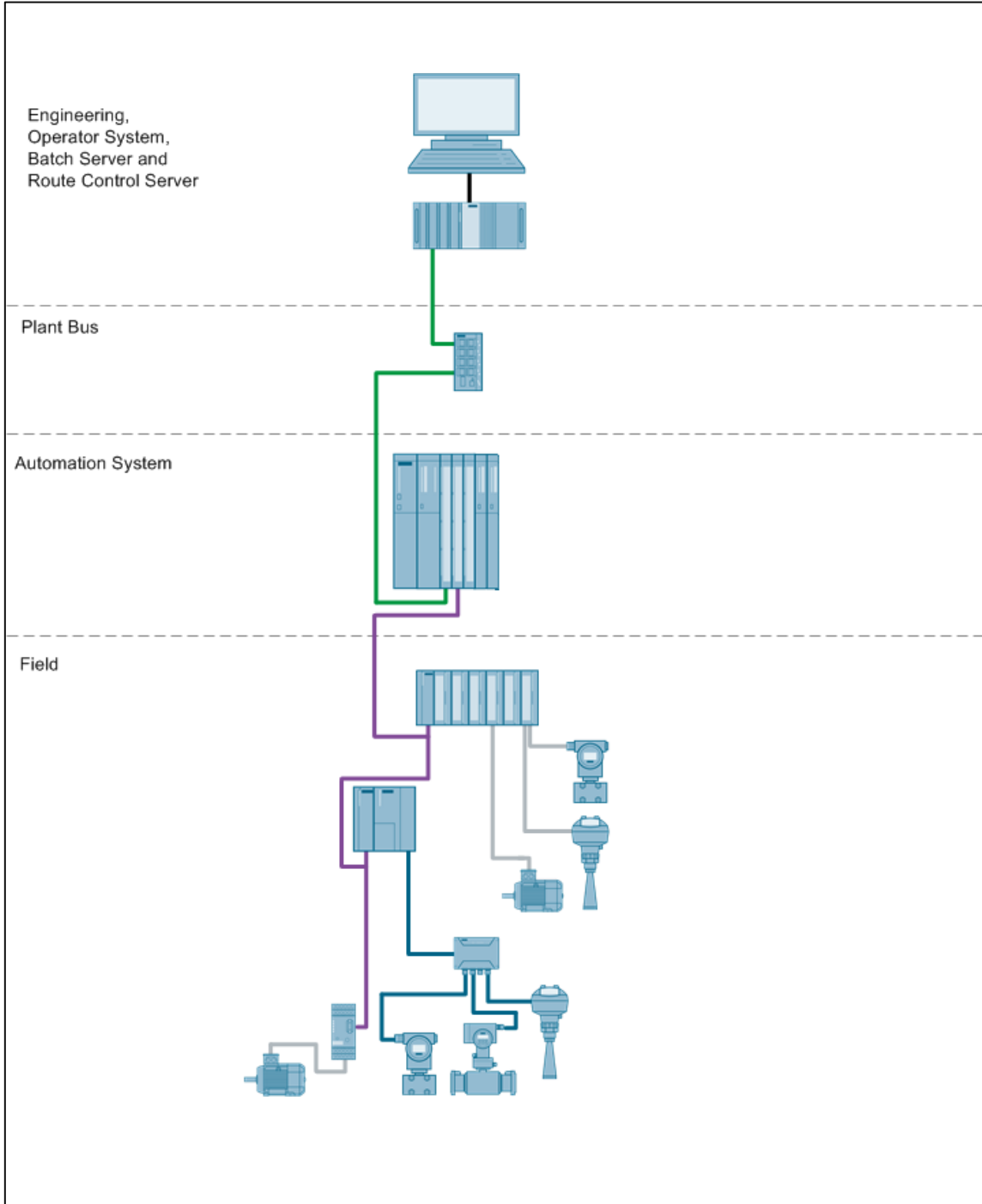

Bill of material for SIMATIC Route Control and SIMATIC BATCH single-user system

Table 10–1

Required	Optional	Product number	Product description	Note
Engineering, Operator System, Route Control and Batch server				
1		6ES7660-2AA30-1CA0	SIMATIC PCS 7 INDUSTRIAL WORKSTATION IPC847C, CORE I7, ES/OS SINGLESTATION, RAID1 (500GB INTERNAL), 8GB DDR3, BCE, PCS 7 V8.0 SP1, WIN 7	
1		6ES7 658-5AX08-0YA5	SOFTWARE SIMATIC PCS 7 AS/OS ENGINEERING V8.0	
1		6ES7 658-2AA08-0YA0	SOFTWARE SIMATIC PCS 7 OS SOFTWARE SINGLE STATION V8.0 (PO 100)	1)
	1	6ES7 652-0XD08-2YB5	SOFTWARE SIMATIC PCS 7 SFC VISUALIZATION V8.0	
	1	6ES7 658-1CX17-2YA5	SOFTWARE SIMATIC PCS 7 VERSION CROSS MANAGER V7.1	
	1	6ES7 658-1DX08-2YB5	SOFTWARE SIMATIC PCS 7 IMPORT EXPORT ASSISTANT V8.0	
	1	6ES7 658-1FX08-2YA5	SOFTWARE SIMATIC PCS 7 VERSION TRAIL V8.0	
1		6ES7 658-7DX08-0YB5	SOFTWARE SIMATIC ROUTE CONTROL ENGINEERING V8.0	
1		6ES7 658-7FX08-0YB0	SOFTWARE SIMATIC ROUTE CONTROL SERVER V8.0	
1		6ES7 658-7FF00-0XB0	SOFTWARE SIMATIC ROUTE CONTROL (10 ROUTES) V8.0	4)
1		6ES7 658-7EX08-0YB5	SOFTWARE SIMATIC ROUTE CONTROL CONTROL CENTER V8.0	
1		6ES7 657-0TX08-0YB0	SOFTWARE SIMATIC BATCH SERVER V8.0	
1		6ES7 657-0XB00-0YB0	SOFTWARE SIMATIC BATCH (10 UNITS) V8.0	5)

Required	Optional	Product number	Product description	Note
System bus				
1		6GK5 208-0BA10-2AA3	SIMATIC NET SCALANCE X208, MANAGED IE SWITCH, 8 X 10/100MBIT/S	2)
2		6XV1 870-3QH60	SIMATIC NET INDUSTRIAL ETHERNET TP CORD CABLE RJ45/RJ45, 6M	
Automation system				
1		6ES7 654-6CL03-3BF0	SIMATIC PCS 7 SINGLE AS, CPU 410-5H, 1X DP-MODULE, 1x PROFINET-IO, SYSTEM EXPANSIONS CARD 500 PO, AS RT PO 100, CP443-1IE, UR2 ALU RACK, 1 X UC 120/230V 10A POWER SUPPLYSIMATIC	1) 3)

Note

- 1) The number of POs can be increased later on by means of extra volume licenses.
- 2) SCALANCE switch requires a 24VDC power supply (not listed).
- 3) Please use the PCS 7 AS configurator, as the PCS 7 AS 410-5H is available in different versions, e.g. 24V DC or 110/230V AC.
- 4) At least one "SIMATIC Route Control Routes" license (for sets of 10/50) is required per project. The number of routes can be increased at a later stage with cumulative "SIMATIC Route Control Routes" licenses.
- 5) The number of batch units can be increased by means of cumulative batch unit licenses.

10.2 SIMATIC Route Control and SIMATIC BATCH client/server

Figure 10-2

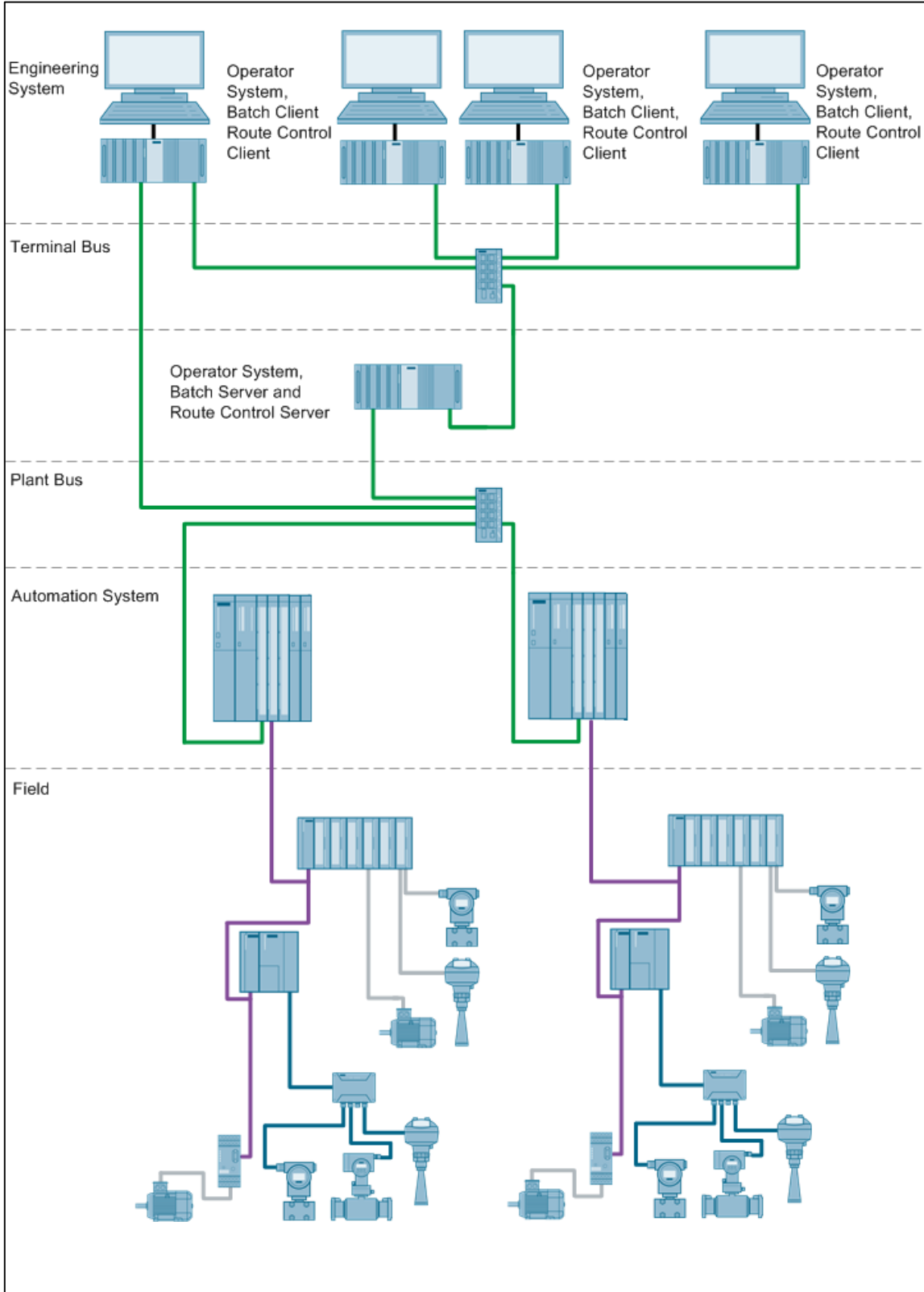

Copyright © Siemens AG 2013 All rights reserved

Bill of material for SIMATIC Route Control and SIMATIC BATCH client/server system

Table 10–2

Required	Optional	Product number	Product description	Note
Engineering System				
1		6ES7660-2AA30-1CA0	SIMATIC PCS 7 INDUSTRIAL WORKSTATION IPC847C, CORE I7, ES/OS SINGLESTATION, RAID1 (500GB INTERNAL), 8GB DDR3, BCE, PCS 7 V8.0 SP1, WIN 7	
1		6ES7 658-5AX08-0YA5	SOFTWARE SIMATIC PCS 7 AS/OS ENGINEERING V8.0	
1		6ES7 658-7DX08-0YB5	SOFTWARE SIMATIC ROUTE CONTROL ENGINEERING V8.0	
	1	6ES7 658-1CX17-2YA5	SOFTWARE SIMATIC PCS 7 VERSION CROSS MANAGER V7.1	
	1	6ES7 658-1FX08-2YA5	SOFTWARE SIMATIC PCS 7 VERSION TRAIL V8.0	
	1	6ES7 658-1DX08-2YB5	SOFTWARE SIMATIC PCS 7 IMPORT EXPORT ASSISTANT V8.0	
Operator System, Route Control and Batch server				
1		6ES7660-2BA30-1DA0	SIMATIC PCS 7 INDUSTRIAL WORKSTATION IPC847C, CORE I7, OS SERVER, RAID1 (500GB INTERNAL), 8GB DDR3, BCE, PCS 7 V8.0 SP1, WIN SERVER 2008	
1		6ES7 658-2BA08-0YA0	SOFTWARE SIMATIC PCS 7 OS SOFTWARE SERVER V8.0 (PO 100)	1)
1		6ES7 658-7FX08-0YB0	SOFTWARE SIMATIC ROUTE CONTROL SERVER V8.0	
1		6ES7 658-7FF00-0XB0	SOFTWARE SIMATIC ROUTE CONTROL (10 ROUTES) V8.0	6)
1		6ES7 657-0TX08-0YB0	SOFTWARE SIMATIC BATCH SERVER V8.0	
1		6ES7 657-0XB00-0YB0	SOFTWARE SIMATIC BATCH (10 UNITS) V8.0	4)
Operator System, Route Control and Batch client				
3		6ES7660-1CA18-1CA0	SIMATIC PCS 7 INDUSTRIAL WORKSTATION IPC647C, CORE I7, OS CLIENT, 500GB INTERNAL, 4GB DDR3, PCS 7 V8.0 SP1, WIN 7	
3		6ES7 658-2CX08-0YB5	SOFTWARE SIMATIC PCS 7 OS CLIENT V8.0	
	3	6ES7 652-0XD08-2YB5	SOFTWARE SIMATIC PCS 7 SFC VISUALIZATION V8.0	
3		6ES7 658-7EX08-0YB5	SOFTWARE SIMATIC ROUTE CONTROL CONTROL CENTER V8.0	
2	1	6ES7 657-0VX08-0YB5	SOFTWARE SIMATIC BATCH CLIENT V8.0	
1	2	6ES7 657-0AX08-0YB5	SOFTWARE SIMATIC BATCH RECIPE SYSTEM V8.0	5)

Required	Optional	Product number	Product description	Note
Terminal bus				
1		6GK5 208-0BA10-2AA3	SIMATIC NET SCALANCE X208, MANAGED IE SWITCH, 8 X 10/100MBIT/S	²⁾
5		6XV1 870-3QH60	SIMATIC NET INDUSTRIAL ETHERNET TP CORD CABLE RJ45/RJ45, 6M	
System bus				
1		6GK5 208-0BA10-2AA3	SIMATIC NET SCALANCE X208, MANAGED IE SWITCH, 8 X 10/100MBIT/S	²⁾
4		6XV1 870-3QH60	SIMATIC NET INDUSTRIAL ETHERNET TP CORD CABLE RJ45/RJ45, 6M	
Automation system				
2		6ES7 654-6CN03-3BF0	SIMATIC PCS 7 SINGLE AS, CPU 410-5H, 1X DP-MODULE, 1x PROFINET-IO, SYSTEM EXPANSIONS CARD 1000 PO, AS RT PO 100, CP443-1IE, UR2 ALU RACK, 1 X UC 120/230V 10A POWER SUPPLY SIMATIC	³⁾

Note

- ¹⁾ The number of POs can be increased later on by means of extra volume licenses.
- ²⁾ SCALANCE switch requires a 24VDC power supply (not listed).
- ³⁾ Please use the PCS 7 AS configurator, as the PCS 7 AS 410-5H is available in different versions, e.g. 24V DC or 110/230V AC.
- ⁴⁾ The number of batch units can be increased by means of cumulative batch unit licenses.
- ⁵⁾ The SIMATIC BATCH recipe system license is required on at least one client of a client/server system (on all clients that could be used to create and edit recipes).
- ⁶⁾ At least one "SIMATIC Route Control Routes" license (for sets of 10/50) is required per project. The number of routes can be increased at a later stage with cumulative "SIMATIC Route Control Routes" licenses.

10.3 Redundant SIMATIC Route Control and SIMATIC BATCH client/server

Figure 10-3

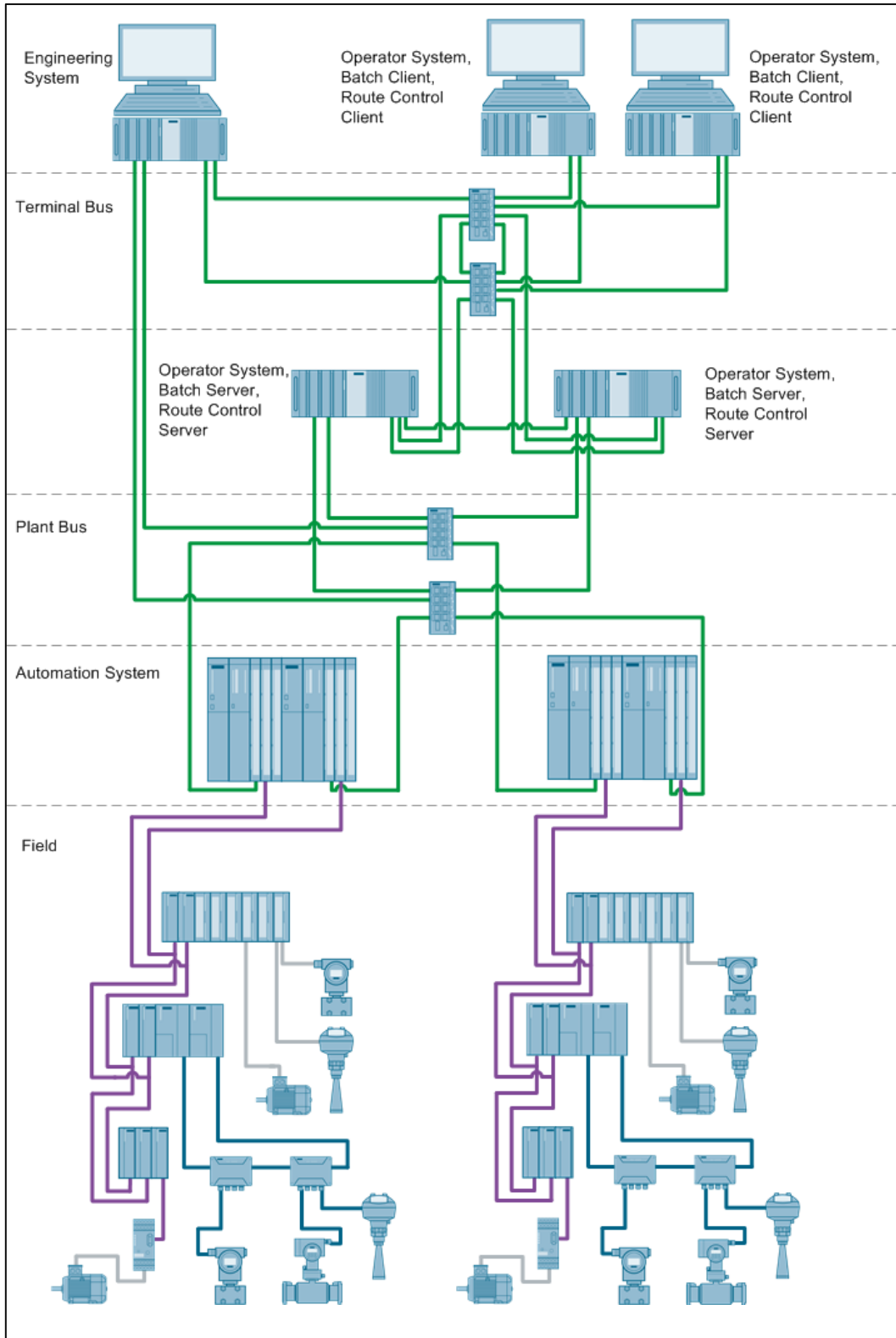

Copyright © Siemens AG 2013 All rights reserved

Bill of material for the redundant SIMATIC Route Control and SIMATIC BATCH client/server system

Table 10–3

Required	Optional	Product number	Product description	Note
Engineering System				
1		6ES7660-2AA30-1CA0	SIMATIC PCS 7 INDUSTRIAL WORKSTATION IPC847C, CORE I7, ES/OS SINGLESTATION, RAID1 (500GB INTERNAL), 8GB DDR3, BCE, PCS 7 V8.0 SP1, WIN 7	
1		6ES7 658-5AX08-0YA5	SOFTWARE SIMATIC PCS 7 AS/OS ENGINEERING V8.0	
1		6GK1 162-3AA00	SIMATIC NET COMMUNICATION PROCESSOR CP 1623 PCI EXPRESS	1)
1		6GK1 716-0HB08-1AC0	SIMATIC NET, S7-REDCONNECT POWERPACK	4)
1		6ES7 652-0XX01-1XF1	SIMATIC PCS 7 REDUNDANT TERMINAL BUS ADAPTER PACKAGE, 2 X INTEL PCI-E (EXPRESS) NETWORK CARD	2)
1		6ES7 658-7DX08-0YB5	SOFTWARE SIMATIC ROUTE CONTROL ENGINEERING V8.0	
	1	6ES7 658-1CX17-2YA5	SOFTWARE SIMATIC PCS 7 VERSION CROSS MANAGER V7.1	
	1	6ES7 658-1FX08-2YA5	SOFTWARE SIMATIC PCS 7 VERSION TRAIL V8.0	
	1	6ES7 658-1DX08-2YB5	SOFTWARE SIMATIC PCS 7 IMPORT EXPORT ASSISTANT V8.0	
Operator System, Route Control and Batch server				
2		6ES7660-2BB31-1DA0	SIMATIC PCS 7 INDUSTRIAL WORKSTATION IPC847C, CORE I7, OS SERVER, RAID1 (500GB FRONT MOUNTED), 8GB DDR3, INDUSTRIAL ETHERNET (CP1623), PCS 7 V8.0 SP1, WIN SERVER 2008	
1		6ES7 652-3BA08-2YA0	SOFTWARE SIMATIC PCS 7 OS SERVER REDUNDANCY V8.0 (PO 100)	3)
2		6GK1 162-3AA00	SIMATIC NET COMMUNICATION PROCESSOR CP 1623 PCI EXPRESS	1)
2		6GK1 716-0HB08-1AC0	SIMATIC NET, S7-REDCONNECT POWERPACK	4)
2		6ES7 652-0XX01-1XF1	SIMATIC PCS 7 REDUNDANT TERMINAL BUS ADAPTER PACKAGE, 2 X INTEL PCI-E (EXPRESS) NETWORK CARD	3)
2		A5E02639550	DESKTOP ADAPTER NETWORK CARD	8)
1		6XV1 870-3RH60	SIMATIC NET INDUSTRIAL ETHERNET TP XP CORD RJ45/RJ45, 6M	
2		6ES7 658-7FX08-0YB0	SOFTWARE SIMATIC ROUTE CONTROL SERVER V8.0	
2		6ES7 658-7FF00-0XB0	SOFTWARE SIMATIC ROUTE CONTROL (10 ROUTES) V8.0	10)
2		6ES7 657-0TX08-0YB0	SOFTWARE SIMATIC BATCH SERVER V8.0	
2		6ES7 657-0XB00-0YB0	SOFTWARE SIMATIC BATCH (10 UNITS) V8.0	7)

10 SIMATIC Route Control and SIMATIC BATCH

Required	Optional	Product number	Product description	Note
Operator System, Route Control and Batch client				
2		6ES7660-1CA18-1CA0	SIMATIC PCS 7 INDUSTRIAL WORKSTATION IPC647C, CORE I7, OS CLIENT, 500GB INTERNAL, 4GB DDR3, PCS 7 V8.0 SP1, WIN 7	
2		6ES7 652-0XX01-1XF1	SIMATIC PCS 7 REDUNDANT TERMINAL BUS ADAPTER PACKAGE, 2 X INTEL PCI-E (EXPRESS) NETWORK CARD	³⁾
2		6ES7 658-2CX08-0YB5	SOFTWARE SIMATIC PCS 7 OS CLIENT V8.0	
	2	6ES7 652-0XD08-2YB5	SOFTWARE SIMATIC PCS 7 SFC VISUALIZATION V8.0	
2		6ES7 658-7EX08-0YB5	SOFTWARE SIMATIC ROUTE CONTROL CONTROL CENTER V8.0	
2		6ES7 657-0VX08-0YB5	SOFTWARE SIMATIC BATCH CLIENT V8.0	
1	1	6ES7 657-0AX08-0YB5	SOFTWARE SIMATIC BATCH RECIPE SYSTEM V8.0	⁹⁾
Terminal bus				
2		6GK5 208-0BA10-2AA3	SIMATIC NET SCALANCE X208, MANAGED IE SWITCH, 8 X 10/100MBIT/S	⁵⁾
12		6XV1 870-3QH60	SIMATIC NET INDUSTRIAL ETHERNET TP CORD CABLE RJ45/RJ45, 6M	
System bus				
2		6GK5 208-0BA10-2AA3	SIMATIC NET SCALANCE X208, MANAGED IE SWITCH, 8 X 10/100MBIT/S	⁵⁾
12		6XV1 870-3QH60	SIMATIC NET INDUSTRIAL ETHERNET TP CORD CABLE RJ45/RJ45, 6M	
Automation system				
2		6ES7 656-6CN33-1CF0	SIMATIC PCS 7 REDUNDANCY AS, 2X CPU 410-5H, 2 DP-MODULE, 2X PROFINET-IO, SYSTEM EXPANSION CARD 1000, AS RT PO 100, 2 X 2 10M SYNC-MODULE AND 2 X 1M FO, 2 X CP443-1 IE/PN, 1 X UR2-H ALU RACK, 2 X UC 120/230V 10A RED. POWER SUPPLY	⁶⁾

Note

- ¹⁾ Required in case a redundant system bus is chosen.
- ²⁾ Required in case a redundant terminal bus is chosen.
- ³⁾ The number of POs can be increased later on by means of extra volume licenses.
- ⁴⁾ Required in case a redundant system bus or a redundant automation system is chosen.
- ⁵⁾ SCALANCE switch requires a 24VDC power supply (not listed).
- ⁶⁾ Please use the PCS 7 AS configurator, as the PCS 7 AS 410-5H is available in different versions, e.g. 24V DC or 110/230V AC.
- ⁷⁾ The number of batch units can be increased by means of cumulative batch unit licenses.
- ⁸⁾ Additional network cards are required for redundancy switching.
- ⁹⁾ The SIMATIC BATCH recipe system license is required on at least one client of a client/server system (on all clients that should be used to create and edit recipes).
- ¹⁰⁾ At least one "SIMATIC Route Control Routes" license (for sets of 10/50) is required per project. The number of routes can be increased at a later stage with cumulative "SIMATIC Route Control Routes" licenses.

10.4 SIMATIC Route Control and SIMATIC BATCH multi-server

Figure 10-4

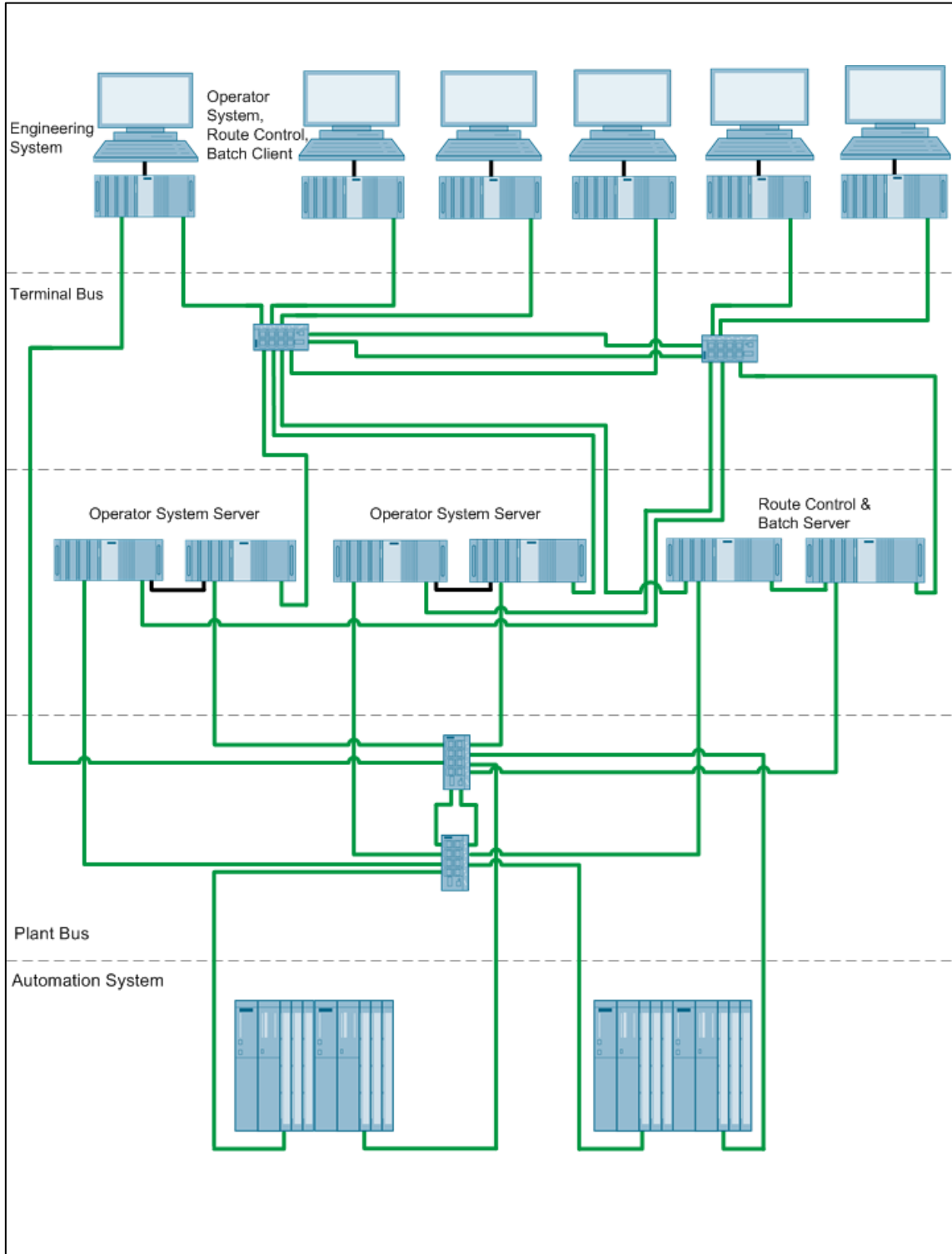

Copyright © Siemens AG 2013 All rights reserved

Bill of material for the SIMATIC Route Control and SIMATIC BATCH multi-server system

Table 10–4

Required	Optional	Product number	Product description	Note
Engineering System				
1		6ES7 660-2AA31-1CA0	SIMATIC PCS 7 INDUSTRIAL WORKSTATION IPC847C, CORE I7, ES/OS SINGLESTATION, RAID1 (500GB FRONT MOUNTED), 8GB DDR3, INDUSTRIAL ETHERNET (CP1623), PCS 7 V8.0 SP1, WIN 7	1)
1		6GK1 716-0HB08-1AC0	SIMATIC NET, S7-REDCONNECT POWERPACK	1)
1		6ES7 658-5AX08-0YA5	SOFTWARE SIMATIC PCS 7 AS/OS ENGINEERING V8.0	
1		6ES7 658-7DX08-0YB5	SOFTWARE SIMATIC ROUTE CONTROL ENGINEERING V8.0	
	1	6ES7 658-1CX17-2YA5	SOFTWARE SIMATIC PCS 7 VERSION CROSS MANAGER V7.1	
	1	6ES7 658-1FX08-2YA5	SOFTWARE SIMATIC PCS 7 VERSION TRAIL V8.0	
	1	6ES7 658-1DX08-2YB5	SOFTWARE SIMATIC PCS 7 IMPORT EXPORT ASSISTANT V8.0	
Operator System server				
4		6ES7660-2BB31-1DA0	SIMATIC PCS 7 INDUSTRIAL WORKSTATION IPC847C, CORE I7, OS SERVER, RAID1 (500GB FRONT MOUNTED), 8GB DDR3, INDUSTRIAL ETHERNET (CP1623), PCS 7 V8.0 SP1, WIN SERVER 2008	1)
4		6GK1 716-0HB08-1AC0	SIMATIC NET, S7-REDCONNECT POWERPACK	1)
2		6ES7 652-3BA08-2YA0	SOFTWARE SIMATIC PCS 7 OS SERVER REDUNDANCY V8.0 (PO 100)	2) 7)
Route Control and Batch server				
2		6ES7660-2BB31-1DA0	SIMATIC PCS 7 INDUSTRIAL WORKSTATION IPC847C, CORE I7, OS SERVER, RAID1 (500GB FRONT MOUNTED), 8GB DDR3, INDUSTRIAL ETHERNET (CP1623), PCS 7 V8.0 SP1, WIN SERVER 2008	
2		6GK1 716-0HB08-1AC0	SIMATIC NET, S7-REDCONNECT POWERPACK	1)
2		A5E02639550	DESKTOP ADAPTER NETWORK CARD	6)
1		6XV1 870-3RH60	SIMATIC NET INDUSTRIAL ETHERNET TP XP CORD RJ45/RJ45, 6M	
2		6ES7 658-7FX08-0YB0	SOFTWARE SIMATIC ROUTE CONTROL SERVER V8.0	
2		6ES7 658-7FF00-0XB0	SOFTWARE SIMATIC ROUTE CONTROL (10 ROUTES) V8.0	9)
2		6ES7 657-0TX08-0YB0	SOFTWARE SIMATIC BATCH SERVER V8.0	
2		6ES7 657-0XB00-0YB0	SOFTWARE SIMATIC BATCH (10 UNITS) V8.0	5)

10 SIMATIC Route Control and SIMATIC BATCH

Required	Optional	Product number	Product description	Note
Operator System, Route Control and Batch client				
5		6ES7660-1CA18-1CA0	SIMATIC PCS 7 INDUSTRIAL WORKSTATION IPC647C, CORE I7, OS CLIENT, 500GB INTERNAL, 4GB DDR3, PCS 7 V8.0 SP1, WIN 7	
5		6ES7 658-2CX08-0YB5	SOFTWARE SIMATIC PCS 7 OS CLIENT V8.0	
	5	6ES7 652-0XD08-2YB5	SOFTWARE SIMATIC PCS 7 SFC VISUALIZATION V8.0	
5		6ES7 658-7EX08-0YB5	SOFTWARE SIMATIC ROUTE CONTROL CONTROL CENTER V8.0	
2	3	6ES7 657-0VX08-0YB5	SOFTWARE SIMATIC BATCH CLIENT V8.0	
1	4	6ES7 657-0AX08-0YB5	SOFTWARE SIMATIC BATCH RECIPE SYSTEM V8.0	8)
Terminal bus				
2		6GK5 216-0BA00-2AA3	SIMATIC NET SCALANCE X216, MANAGED IE SWITCH, 16 X 10/100MBIT/S	3)
14		6XV1 870-3QH60	SIMATIC NET INDUSTRIAL ETHERNET TP CORD CABLE RJ45/RJ45, 6M	
System bus				
2		6GK5 208-0BA10-2AA3	SIMATIC NET SCALANCE X208, MANAGED IE SWITCH, 8 X 10/100MBIT/S	3)
13		6XV1 870-3QH60	SIMATIC NET INDUSTRIAL ETHERNET TP CORD CABLE RJ45/RJ45, 6M	
Automation system				
2		6ES7 656-6CQ33-1CF0	SIMATIC PCS 7 REDUNDANCY AS, 2X CPU 410-5H, 2 DP-MODULE, 2X PROFINET-IO, SYSTEM EXPANSION CARD 2k+, AS RT PO 100, 2 X 2 10M SYNC-MODULE AND 2 X 1M FO, 2 X CP443-1 IE/PN, 1 X UR2-H ALU RACK, 2 X UC 120/230V 10A RED. POWER SUPPLY	4)

Note

- ¹⁾ Needed for a redundant automation system.
- ²⁾ The number of POs can be increased later on by means of extra volume licenses.
- ³⁾ SCALANCE switch requires a 24VDC power supply (not listed).
- ⁴⁾ Please use the PCS 7 AS configurator, as the PCS 7 AS 410-5H is available in different versions, e.g. 24V DC or 110/230V AC.
- ⁵⁾ The number of batch units can be increased by means of cumulative batch unit licenses.
- ⁶⁾ Additional network cards are required for redundancy switching.
- ⁷⁾ The redundant OS server is supplied with an RS-232 serial connection cable. If there is a long distance between the redundant systems, one can use an Ethernet connection as an alternative. This requires additional Ethernet network interface cards in the systems.
- ⁸⁾ The SIMATIC BATCH recipe system license is required on at least one client of a client/server system (on all clients that should be used to create and edit recipes).
- ⁹⁾ At least one "SIMATIC Route Control Routes" license (for sets of 10/50) is required per project. The number of routes can be increased at a later stage with cumulative "SIMATIC Route Control Routes" licenses.

11 Archiving

SIMATIC PCS 7 archiving

The archiving of data for analysis purposes in OS clients, where the system collects large amounts of data over long periods, is supported by the Process Historian. The Process Historian collects the archive data from the OS servers. These can be visualized directly or with the assistance of the information server on OS clients or single stations. For long-term archiving, archive data from the Process Historian can be stored on external media (such as backup drives or DVDs) and retrieved for further analysis.

Client/server system

The Process Historian generally runs on a separate PC. The basic hardware for the Process Historian is the SIMATIC PCS 7 Industrial Workstation of the type IPC847C, server version, with an additional hard disk for the operating system and SIMATIC PCS 7 software. A RAID 5 hard disk configuration can be used for the database.

Note The use of a Fujitsu Primergy server is recommended for larger quantity structures (more than 3 OS servers in the maximum archive configuration) (see under Premium Server in the catalog ST PCS 7 AO, Add-ons for SIMATIC PCS 7).

All OS clients can retrieve data from the Process Historian, i.e. there is no difference between accessing data on the OS server and data on the Process Historian. Redundant OS server, single Process Historian

If redundant operation and monitoring are required and a high availability of archive data is not mandatory, a single Process Historian can be connected to a redundant OS server pair.

Redundant Process Historian

If high availability of archive data is needed, as from SIMATIC PCS 7 V8.0 SP1, SIMATIC PCS 7 offers the option of a redundant Process Historian.

Storage Plus

Storage plus is installed on a separate PC to create and administer a long-term archive. The data of the long-term archive can be retrieved from the separate PC, tested through a viewer and exported.

Information Server

The Information Server is the reporting system of the Process Historian. Based on the Microsoft Reporting Services, it offers web-based thin-client access to the historical data. Add-ins for Microsoft Word and Excel provide additional access to the database of the Process Historian. The Information Server can be installed and operated on the Process Historian hardware or on separate hardware. When the Process Historian is configured redundantly, the separation of the Information Server is mandatory. Any OS client version of the SIMATIC PCS 7 Industrial Workstation is suitable for the separate Information Server

11.1 Client/server

Figure 11-1

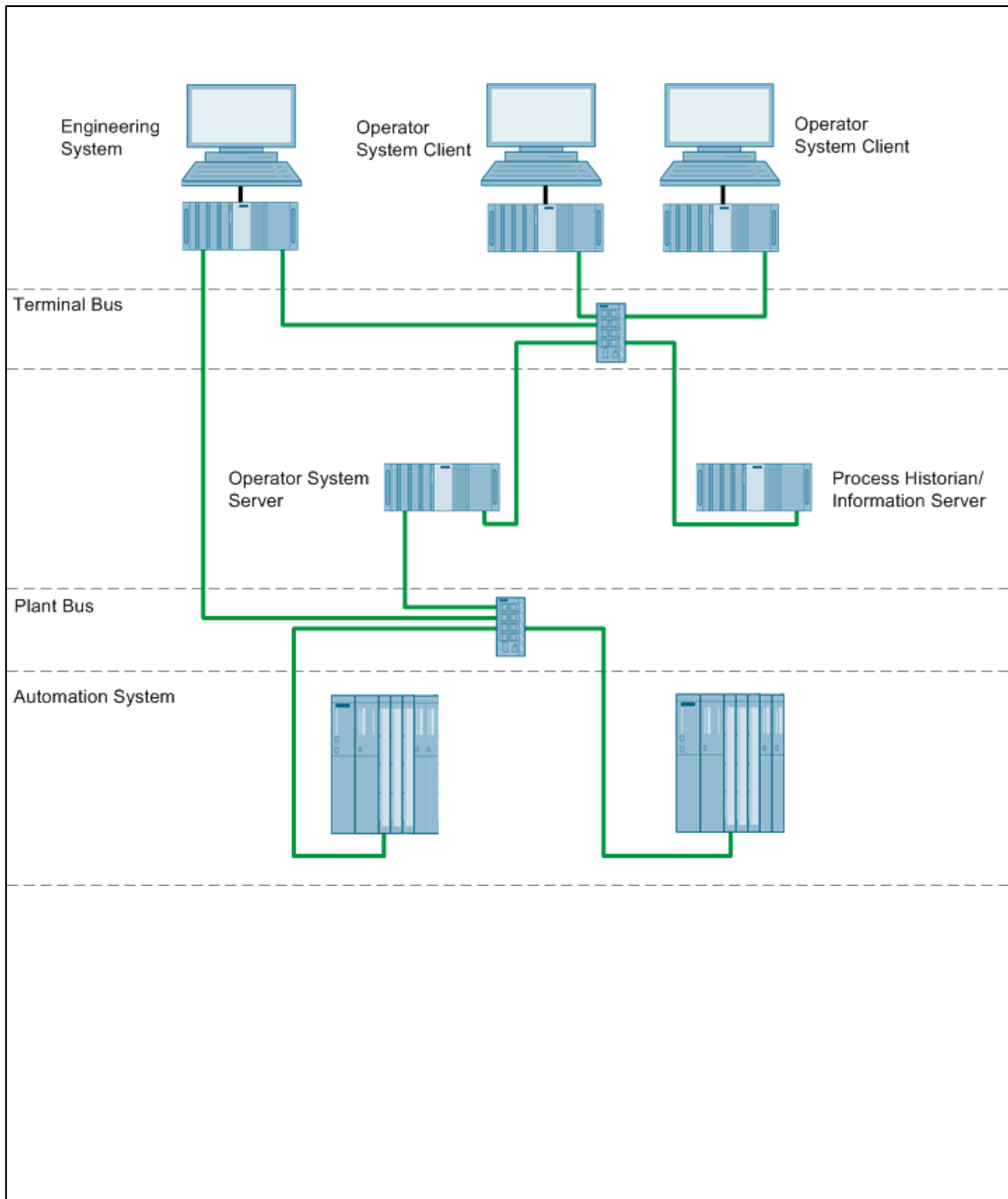

Copyright © Siemens AG 2013 All rights reserved

Bill of material for the client/server architecture

Table 11-1

Required	Optional	Product number	Product description	Note
Engineering System				
1		6ES7660-2AA30-1CA0	SIMATIC PCS 7 INDUSTRIAL WORKSTATION IPC847C, CORE I7, ES/OS SINGLESTATION, RAID1 (500GB INTERNAL), 8GB DDR3, BCE, PCS 7 V8.0 SP1, WIN 7	
1		6ES7 658-5AX08-0YA5	SOFTWARE SIMATIC PCS 7 AS/OS ENGINEERING V8.0	
	1	6ES7 658-1CX17-2YA5	SOFTWARE SIMATIC PCS 7 VERSION CROSS MANAGER V7.1	
	1	6ES7 658-1FX08-2YA5	SOFTWARE SIMATIC PCS 7 VERSION TRAIL V8.0	
	1	6ES7 658-1DX08-2YB5	SOFTWARE SIMATIC PCS 7 IMPORT EXPORT ASSISTANT V8.0	
Operator System server				
1		6ES7660-2BA30-1DA0	SIMATIC PCS 7 INDUSTRIAL WORKSTATION IPC847C, CORE I7, OS SERVER, RAID1 (500GB INTERNAL), 8GB DDR3, BCE, PCS 7 V8.0 SP1, WIN SERVER 2008	
1		6ES7 658-2BA08-0YA0	SOFTWARE SIMATIC PCS 7 OS SOFTWARE SERVER V8.0(PO 100)	1)
Process Historian				
1		6ES7660-2BH38-1DA0	SIMATIC PCS 7 INDUSTRIAL WORKSTATION IPC847C, CORE I7, OS SERVER, RAID5 (3 X 1 TB, HDD SAS) + SSD (100 GB SLC); INTERN., 8GB DDR3, PCS 7 V8.0 SP1, WIN SERVER 2008	
1		6ES7652-7BX08-2YB0	SOFTWARE SIMATIC PCS 7 PROCESS HISTORIAN BASIC PACKAGE V8.0	
	1	6ES7652-7EX08-2YB0	SOFTWARE SIMATIC PCS 7 INFORMATION BASIC PACKAGE V8.0, INCL. 1X CLIENT LICENSE	3) 5)
Operator System client				
2		6ES7660-1CA18-1CA0	SIMATIC PCS 7 INDUSTRIAL WORKSTATION IPC647C, CORE I7, OS CLIENT, 500GB INTERNAL, 4GB DDR3, PCS 7 V8.0 SP1, WIN 7	
2		6ES7 658-2CX08-0YB5	SOFTWARE SIMATIC PCS 7 OS CLIENT V8.0	
	2	6ES7 652-0XD08-2YB5	SOFTWARE SIMATIC PCS 7 SFC VISUALIZATION V8.0	

Required	Optional	Product number	Product description	Note
Terminal bus				
1		6GK5 208-0BA10-2AA3	SIMATIC NET SCALANCE X208, MANAGED IE SWITCH, 8 X 10/100MBIT/S	²⁾
5		6XV1 870-3QH60	SIMATIC NET INDUSTRIAL ETHERNET TP CORD CABLE RJ45/RJ45, 6M	
System bus				
1		6GK5 208-0BA10-2AA3	SIMATIC NET SCALANCE X208, MANAGED IE SWITCH, 8 X 10/100MBIT/S	²⁾
4		6XV1 870-3QH60	SIMATIC NET INDUSTRIAL ETHERNET TP CORD CABLE RJ45/RJ45, 6M	
Automation system				
2		6ES7 654-6CN03-3BF0	SIMATIC PCS 7 SINGLE AS, CPU 410-5H, 1X DP-MODULE, 1x PROFINET-IO, SYSTEM EXPANSIONS CARD 1000 PO, AS RT PO 100, CP443-1IE, UR2 ALU RACK, 1 X UC 120/230V 10A POWER SUPPLY SIMATIC	³⁾

Note

- ¹⁾ The number of POs can be increased later on by means of extra volume licenses.
- ²⁾ SCALANCE switch requires a 24VDC power supply (not listed).
- ³⁾ Please use the PCS 7 AS configurator, as the PCS 7 AS 410-5H is available in different versions, e.g. 24V DC or 110/230V AC.
- ⁴⁾ The tag inventory can be expanded to a maximum of 120 000 archive tags using cumulative SIMATIC PCS 7 OS/PH Archive volume licenses.
- ⁵⁾ The number of clients can be expanded with cumulative Information Server client access licenses.

11.2 Redundant OS Server and single Process Historian

Figure 11-2

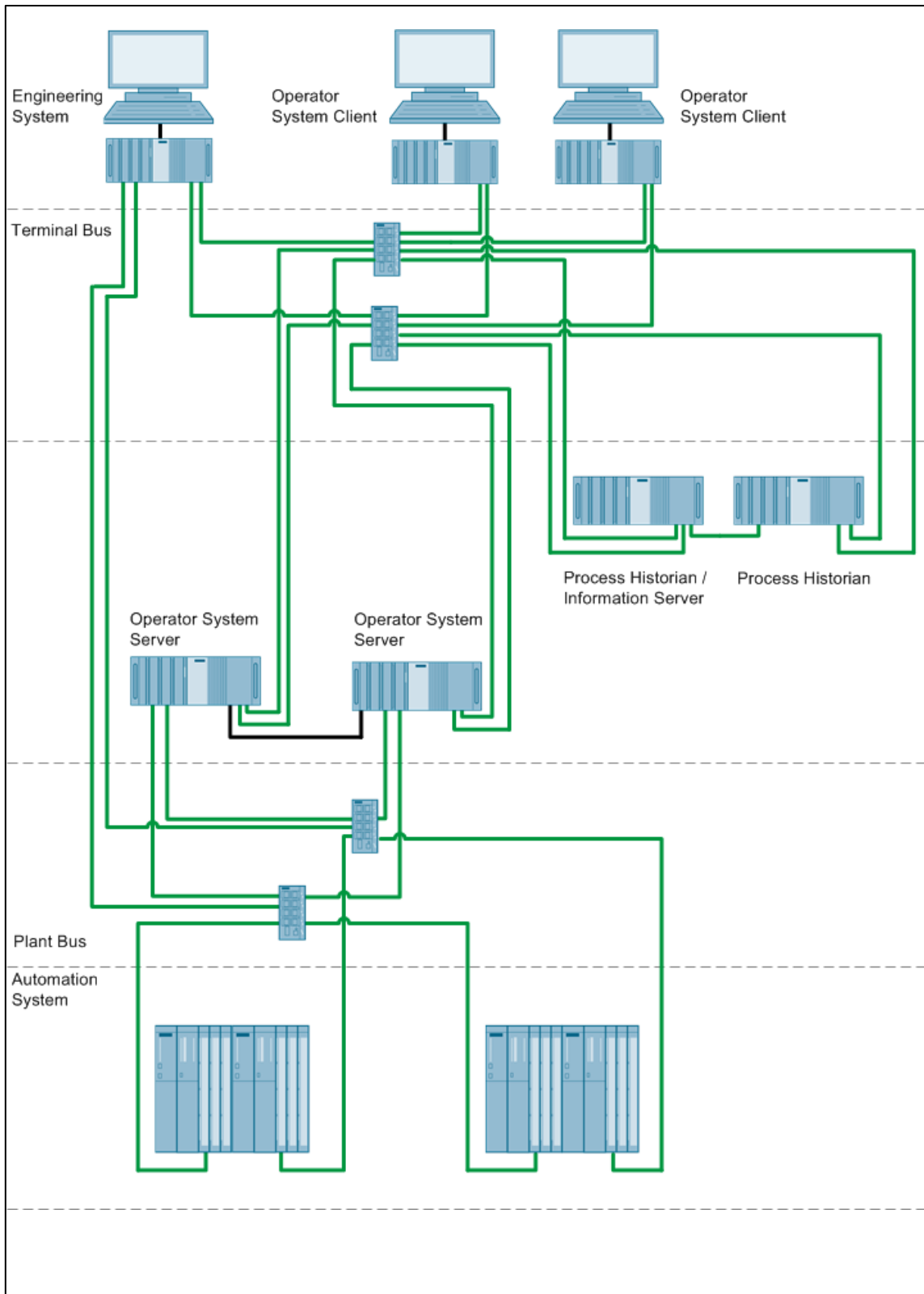

Copyright © Siemens AG 2013 All rights reserved

Bill of material for the redundant OS Server, single Central Archive server

Table 11–2

Required	Optional	Product number	Product description	Note
Engineering System				
1		6ES7660-2BB31-1DA0	SIMATIC PCS 7 INDUSTRIAL WORKSTATION IPC847C, CORE I7, OS SERVER, RAID1 (500GB FRONT MOUNTED), 8GB DDR3, INDUSTRIAL ETHERNET (CP1623), PCS 7 V8.0 SP1, WIN SERVER 2008	
1		6ES7 658-5AX08-0YA5	SOFTWARE SIMATIC PCS 7 AS/OS ENGINEERING V8.0	
1		6GK1 162-3AA00	SIMATIC NET COMMUNICATION PROCESSOR CP 1623 PCI EXPRESS	1)
1		6GK1 716-0HB08-1AC0	SIMATIC NET, S7-REDCONNECT POWERPACK	4)
1		6ES7 652-0XX01-1XF1	SIMATIC PCS 7 REDUNDANT TERMINAL BUS ADAPTER PACKAGE, 2 X INTEL PCI-E (EXPRESS) NETWORK CARD	2)
	1	6ES7 658-1CX17-2YA5	SOFTWARE SIMATIC PCS 7 VERSION CROSS MANAGER V7.1	
	1	6ES7 658-1FX08-2YA5	SOFTWARE SIMATIC PCS 7 VERSION TRAIL V8.0	
	1	6ES7 658-1DX08-2YB5	SOFTWARE SIMATIC PCS 7 IMPORT EXPORT ASSISTANT V8.0	
Operator System server				
2		6ES7660-2BB31-1DA0	SIMATIC PCS 7 INDUSTRIAL WORKSTATION IPC847C, CORE I7, OS SERVER, RAID1 (500GB FRONT MOUNTED), 8GB DDR3, INDUSTRIAL ETHERNET (CP1623), PCS 7 V8.0 SP1, WIN SERVER 2008	
1		6ES7 652-3BA08-2YA0	SOFTWARE SIMATIC PCS 7 OS SERVER REDUNDANCY V8.0 (PO 100)	3)
2		6GK1 162-3AA00	SIMATIC NET COMMUNICATION PROCESSOR CP 1623 PCI EXPRESS	1)
2		6GK1 716-0HB08-1AC0	SIMATIC NET, S7-REDCONNECT POWERPACK	4)
Process Historian				
1		6ES7660-2BH38-1DA0	SIMATIC PCS 7 INDUSTRIAL WORKSTATION IPC847C, CORE I7, OS SERVER, RAID5 (3 X 1 TB, HDD SAS) + SSD (100 GB SLC); INTERN., 8GB DDR3, PCS 7 V8.0 SP1, WIN SERVER 2008	
1		6ES7652-7BX08-2YB0	SOFTWARE SIMATIC PCS 7 PROCESS HISTORIAN BASIC PACKAGE V8.0	7)
	1	6ES7652-7EX08-2YB0	SOFTWARE SIMATIC PCS 7 INFORMATION BASIC PACKAGE V8.0, INCL. 1X CLIENT LICENSE	9)
1		6ES7 652-0XX01-1XF1	SIMATIC PCS 7 REDUNDANT TERMINAL BUS ADAPTER PACKAGE, 2 X INTEL PCI-E (EXPRESS) NETWORK CARD	2)

Required	Optional	Product number	Product description	Note
Operator System client				
2		6ES7660-1CA18-1CA0	SIMATIC PCS 7 INDUSTRIAL WORKSTATION IPC647C, CORE I7, OS CLIENT, 500GB INTERNAL, 4GB DDR3, PCS 7 V8.0 SP1, WIN 7	
2		6ES7 648-0CB00-0YA0	SIMATIC PC KEYBOARD GERMAN / INTERNATIONAL USB INTERFACE	
2		6ES7 652-0XX01-1XF1	SIMATIC PCS 7 REDUNDANT TERMINAL BUS ADAPTER PACKAGE, 2 X INTEL PCI-E (EXPRESS) NETWORK CARD	2)
2		6ES7 658-2CX08-0YB5	SOFTWARE SIMATIC PCS 7 OS CLIENT V8.0	
	2	6ES7 652-0XD08-2YB5	SOFTWARE SIMATIC PCS 7 SFC VISUALIZATION V8.0	
Terminal bus				
2		6GK5 208-0BA10-2AA3	SIMATIC NET SCALANCE X208, MANAGED IE SWITCH, 8 X 10/100MBIT/S	5)
12		6XV1 870-3QH60	SIMATIC NET INDUSTRIAL ETHERNET TP CORD CABLE RJ45/RJ45, 6M	
System bus				
2		6GK5 208-0BA10-2AA3	SIMATIC NET SCALANCE X208, MANAGED IE SWITCH, 8 X 10/100MBIT/S	5)
10		6XV1 870-3QH60	SIMATIC NET INDUSTRIAL ETHERNET TP CORD CABLE RJ45/RJ45, 6M	
Automation system				
2		6ES7 656-6CN33-1CF0	SIMATIC PCS 7 REDUNDANCY AS, 2X CPU 410-5H, 2 DP-MODULE, 2X PROFINET-IO, SYSTEM EXPANSION CARD 1000, AS RT PO 100, 2 X 2 10M SYNC-MODULE AND 2 X 1M FO, 2 X CP443-1 IE/PN, 1 X UR2-H ALU RACK, 2 X UC 120/230V 10A RED. POWER SUPPLY	6)

Note

- 1) Required in case a redundant system bus is chosen.
- 2) Required in case a redundant terminal bus is chosen.
- 3) The number of POs can be increased later on by means of extra volume licenses.
- 4) Required in case a redundant system bus or a redundant automation system is chosen.
- 5) SCALANCE switch requires a 24VDC power supply (not listed).
- 6) Please use the PCS 7 AS configurator, as the PCS 7 AS 410-5H is available in different versions, e.g. 24V DC or 110/230V AC.
- 7) The tag inventory can be expanded to a maximum of 120 000 archive tags using cumulative SIMATIC PCS 7 OS/PH Archive volume licenses.
- 8) The redundant OS server is supplied with an RS-232 serial connection cable. If there is a long distance between the redundant systems, one can use an Ethernet connection as an alternative. This requires additional Ethernet network interface cards in the systems.
- 9) The number of clients can be expanded with cumulative Information Server client access licenses.

11.3 Redundant OS Server and redundant Process Historian

Figure 11-3

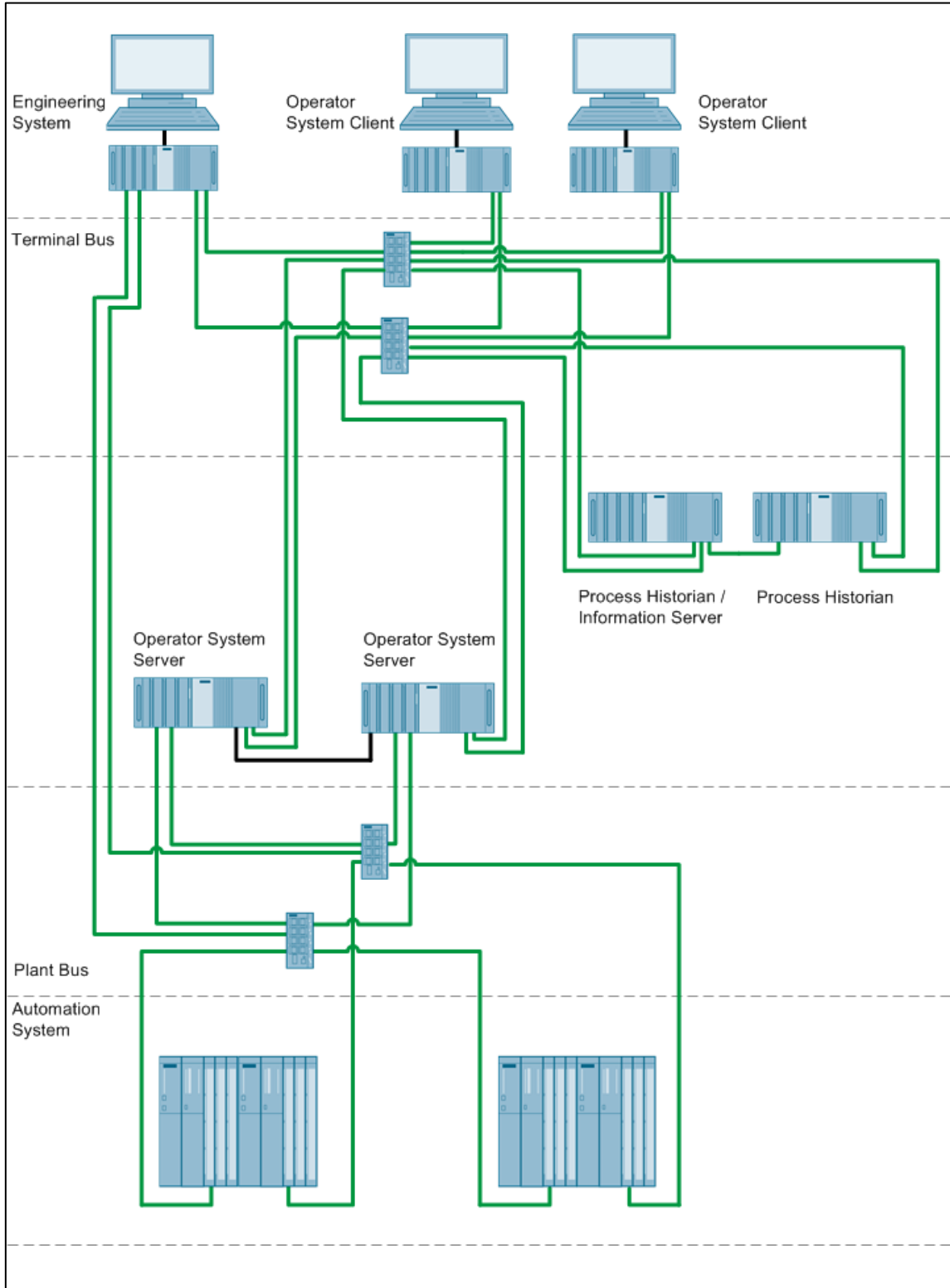

Copyright © Siemens AG 2013 All rights reserved

Bill of material for the redundant OS Server and redundant Central Archive server

Table 11–3

Required	Optional	Product number	Product description	Note
Engineering System				
1		6ES7 660-2AA31-1CA0	SIMATIC PCS 7 INDUSTRIAL WORKSTATION IPC847C, CORE I7, ES/OS SINGLESTATION, RAID1 (500GB FRONT MOUNTED), 8GB DDR3, INDUSTRIAL ETHERNET (CP1623), PCS 7 V8.0 SP1, WIN 7	
1		6ES7 658-5AX08-0YA5	SOFTWARE SIMATIC PCS 7 AS/OS ENGINEERING V8.0	
1		6GK1 162-3AA00	SIMATIC NET COMMUNICATION PROCESSOR CP 1623 PCI EXPRESS	1)
1		6GK1 716-0HB08-1AC0	SIMATIC NET, S7-REDCONNECT POWERPACK	4)
1		6ES7 652-0XX01-1XF1	SIMATIC PCS 7 REDUNDANT TERMINAL BUS ADAPTER PACKAGE, 2 X INTEL PCI-E (EXPRESS) NETWORK CARD	2)
	1	6ES7 658-1CX17-2YA5	SOFTWARE SIMATIC PCS 7 VERSION CROSS MANAGER V7.1	
	1	6ES7 658-1FX08-2YA5	SOFTWARE SIMATIC PCS 7 VERSION TRAIL V8.0	
	1	6ES7 658-1DX08-2YB5	SOFTWARE SIMATIC PCS 7 IMPORT EXPORT ASSISTANT V8.0	
Operator System server				
2		6ES7660-2BB31-1DA0	SIMATIC PCS 7 INDUSTRIAL WORKSTATION IPC847C, CORE I7, OS SERVER, RAID1 (500GB FRONT MOUNTED), 8GB DDR3, INDUSTRIAL ETHERNET (CP1623), PCS 7 V8.0 SP1, WIN SERVER 2008	
1		6ES7 652-3BA08-2YA0	SOFTWARE SIMATIC PCS 7 OS SERVER REDUNDANCY V8.0 (PO 100)	3)
2		6GK1 162-3AA00	SIMATIC NET COMMUNICATION PROCESSOR CP 1623 PCI EXPRESS	1)
2		6GK1 716-0HB08-1AC0	SIMATIC NET, S7-REDCONNECT POWERPACK	4)
Process Historian				
2		6ES7660-2BH38-1DA0	SIMATIC PCS 7 INDUSTRIAL WORKSTATION IPC847C, CORE I7, OS SERVER, RAID5 (3 X 1 TB, HDD SAS) + SSD (100 GB SLC); INTERN., 8GB DDR3, PCS 7 V8.0 SP1, WIN SERVER 2008	
1		6ES7652-7CX08-2YB0	SOFTWARE SIMATIC PCS 7 PROCESS HISTORIAN SERVER REDUNDANCYV8.0	7)
2		6ES7 652-0XX01-1XF1	SIMATIC PCS 7 REDUNDANT TERMINAL BUS ADAPTER PACKAGE, 2 X INTEL PCI-E (EXPRESS) NETWORK CARD	2)
2		A5E02639550	DESKTOP ADAPTER NETWORK CARD	
1		6XV1 870-3RH60	SIMATIC NET INDUSTRIAL ETHERNET TP XP CORD RJ45/RJ45, 6M	1
	1	6ES7652-7EX08-2YB0	SOFTWARE SIMATIC PCS 7 INFORMATION SERVER BASIC PACKAGE V8.0, INCL. 1X CLIENT LICENSE	8)

Required	Optional	Product number	Product description	Note
Operator System client				
2		6ES7660-1CA18-1CA0	SIMATIC PCS 7 INDUSTRIAL WORKSTATION IPC647C, CORE I7, OS CLIENT, 500GB INTERNAL, 4GB DDR3, PCS 7 V8.0 SP1, WIN 7	
2		6ES7 652-0XX01-1XF1	SIMATIC PCS 7 REDUNDANT TERMINAL BUS ADAPTER PACKAGE, 2 X INTEL PCI-E (EXPRESS) NETWORK CARD	²⁾
2		6ES7 658-2CX08-0YB5	SOFTWARE SIMATIC PCS 7 OS CLIENT V8.0	
	2	6ES7 652-0XD08-2YB5	SOFTWARE SIMATIC PCS 7 SFC VISUALIZATION V8.0	
Terminal bus				
2		6GK5 208-0BA10-2AA3	SIMATIC NET SCALANCE X208, MANAGED IE SWITCH, 8 X 10/100MBIT/S	⁵⁾
14		6XV1 870-3QH60	SIMATIC NET INDUSTRIAL ETHERNET TP CORD CABLE RJ45/RJ45, 6M	
System bus				
2		6GK5 208-0BA10-2AA3	SIMATIC NET SCALANCE X208, MANAGED IE SWITCH, 8 X 10/100MBIT/S	⁵⁾
10		6XV1 870-3QH60	SIMATIC NET INDUSTRIAL ETHERNET TP CORD CABLE RJ45/RJ45, 6M	
Automation system				
2		6ES7 656-6CN33-1CF0	SIMATIC PCS 7 REDUNDANCY AS, 2X CPU 410-5H, 2 DP-MODULE, 2X PROFINET-IO, SYSTEM EXPANSION CARD 1000, AS RT PO 100, 2 X 2 10M SYNC-MODULE AND 2 X 1M FO, 2 X CP443-1 IE/PN, 1 X UR2-H ALU RACK, 2 X UC 120/230V 10A RED. POWER SUPPLY	⁶⁾

Note

- 1) Required in case a redundant system bus is chosen.
- 2) Required in case a redundant terminal bus is chosen.
- 3) The number of POs can be increased later on by means of extra volume licenses.
- 4) Required in case a redundant system bus or a redundant automation system is chosen.
- 5) SCALANCE switch requires a 24VDC power supply (not listed).
- 6) Please use the PCS 7 AS configurator, as the PCS 7 AS 410-5H is available in different versions, e.g. 24V DC or 110/230V AC.
- 7) The tag inventory can be expanded to a maximum of 120 000 archive tags using cumulative SIMATIC PCS 7 OS/PH Archive volume licenses.
- 8) The redundant OS server is supplied with an RS-232 serial connection cable. If there is a long distance between the redundant systems, one can use an Ethernet connection as an alternative. This requires additional Ethernet network interface cards in the systems.
- 9) The number of clients can be expanded with cumulative Information Server client access licenses.

11.4 Client/server system with StoragePlus

Figure 11-4

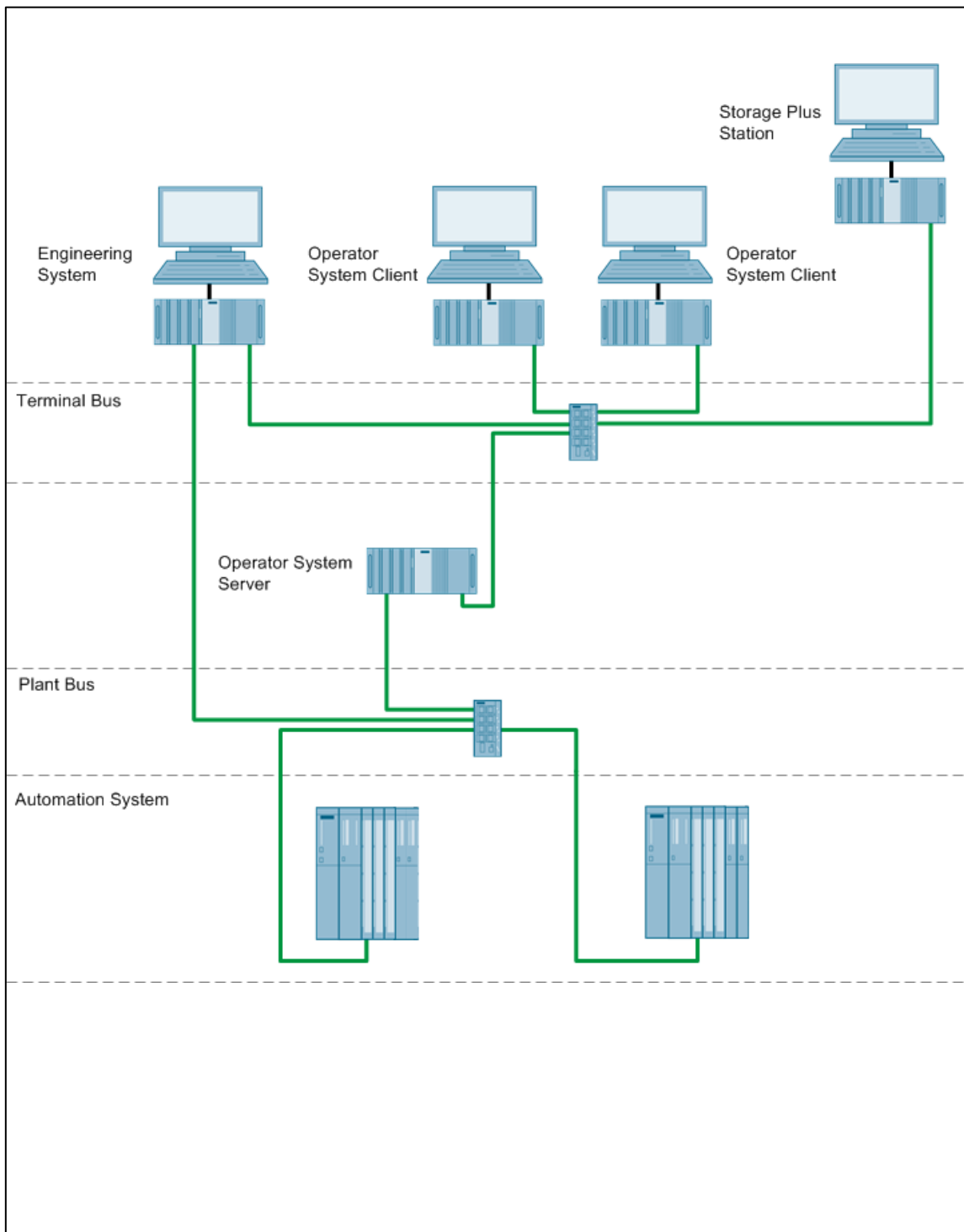

Copyright © Siemens AG 2013 All rights reserved

Bill of material for the client/server system with StoragePlus

Table 11-4

Required	Optional	Product number	Product description	Note
Engineering System				
1		6ES7660-2AA30-1CA0	SIMATIC PCS 7 INDUSTRIAL WORKSTATION IPC847C, CORE I7, ES/OS SINGLESTATION, RAID1 (500GB INTERNAL), 8GB DDR3, BCE, PCS 7 V8.0 SP1, WIN 7	
1		6ES7 658-5AX08-0YA5	SOFTWARE SIMATIC PCS 7 AS/OS ENGINEERING V8.0	
	1	6ES7 658-1CX17-2YA5	SOFTWARE SIMATIC PCS 7 VERSION CROSS MANAGER V7.1	
	1	6ES7 658-1FX08-2YA5	SOFTWARE SIMATIC PCS 7 VERSION TRAIL V8.0	
	1	6ES7 658-1DX08-2YB5	SOFTWARE SIMATIC PCS 7 IMPORT EXPORT ASSISTANT V8.0	
Operator System server				
1		6ES7660-2BA30-1DA0	SIMATIC PCS 7 INDUSTRIAL WORKSTATION IPC847C, CORE I7, OS SERVER, RAID1 (500GB INTERNAL), 8GB DDR3, BCE, PCS 7 V8.0 SP1, WIN SERVER 2008	
1		6ES7 658-2BA08-0YA0	SOFTWARE SIMATIC PCS 7 OS SOFTWARE SERVER V8.0 (PO 100)	¹⁾
Operator System client				
2		6ES7660-1CA18-1CA0	SIMATIC PCS 7 INDUSTRIAL WORKSTATION IPC647C, CORE I7, OS CLIENT, 500GB INTERNAL, 4GB DDR3, PCS 7 V8.0 SP1, WIN 7	
2		6ES7 658-2CX08-0YB5	SOFTWARE SIMATIC PCS 7 OS CLIENT V8.0	
	2	6ES7 652-0XD08-2YB5	SOFTWARE SIMATIC PCS 7 SFC VISUALIZATION V8.0	
Storage Plus station				
1		6ES7660-2AA30-1CA0	SIMATIC PCS 7 INDUSTRIAL WORKSTATION IPC847C, CORE I7, ES/OS SINGLESTATION, RAID1 (500GB INTERNAL), 8GB DDR3, BCE, PCS 7 V8.0 SP1, WIN 7	
1		6ES7 652-0XC08-2YB0	SOFTWARE SIMATIC PCS 7 STORAGE PLUS V8.0	

Required	Optional	Product number	Product description	Note
Terminal bus				
1		6GK5 208-0BA10-2AA3	SIMATIC NET SCALANCE X208, MANAGED IE SWITCH, 8 X 10/100MBIT/S	²⁾
5		6XV1 870-3QH60	SIMATIC NET INDUSTRIAL ETHERNET TP CORD CABLE RJ45/RJ45, 6M	
System bus				
1		6GK5 208-0BA10-2AA3	SIMATIC NET SCALANCE X208, MANAGED IE SWITCH, 8 X 10/100MBIT/S	²⁾
4		6XV1 870-3QH60	SIMATIC NET INDUSTRIAL ETHERNET TP CORD CABLE RJ45/RJ45, 6M	
Automation system				
2		6ES7 654-6CL03-3BF0	SIMATIC PCS 7 SINGLE AS, 4MB MEMORY CARD, CPU 416-3PN, 1X DP-MODULE, AS RT PO 100, CP443-1IE, UR2 ALU RACK, 1 X UC 120/230V 10A POWER SUPPLY	³⁾

Note

- ¹⁾ The number of POs can be increased later on by means of extra volume licenses.
- ²⁾ SCALANCE switch requires a 24VDC power supply (not listed).
- ³⁾ Please use the PCS 7 AS configurator, as the PCS 7 AS 410-5H is available in different versions, e.g. 24V DC or 110/230V AC.

12 SIMATIC PDM

SIMATIC PDM

The SIMATIC Process Device Manager (PDM) enables easy configuration of HART, FOUNDATION Fieldbus H1, PROFIBUS PA and PROFIBUS DP devices that are based on the open EDDL (Electronic Device Description Language) technology.

SIMATIC PDM is a universal tool for parameter assignment, diagnostics, commissioning, servicing and maintenance of field devices. In addition, Asset Management accesses the PDM diagnostic data from field devices.

PDM is fully integrated in the SIMATIC PCS 7 Engineering System.

SIMATIC PDM V8.1 supports communication with devices on PROFINET, PROFIBUS DP, PROFIBUS PA, FOUNDATION Fieldbus H1 and HART (ET200M or ET200iSP modules, modem, RS 232). SIMATIC PDM can be used during stand-alone operation as well as integrated in STEP 7 / PCS 7.

Note

In the PDM Readme file you can find a list of devices supported by a PDM version and profiles.

Stand-alone

When no integration into the PCS 7 Engineering System is required, PDM can also be used, among other things, for the stand-alone mode. The stand-alone version is installed on a standard PC and connected to the PROFIBUS DP fieldbus. This configuration allows you to carry out parameter assignment and maintenance tasks for HART, PROFIBUS PA, PROFIBUS DP and FOUNDATION Fieldbus devices. PROFIBUS DP/PA devices can be accessed from the LifeList. Connected HART devices can also be accessed from a HART modem (point-to-point).

SIMATIC PDM with SIMATIC Field PG at the system bus

In a PCS 7 system, maintenance, servicing and parameter transfer on field devices can be done using a service field PG with SIMATIC PDM. Its robust design is especially ideal for tough day-to-day industrial operation.

Starter System

It already makes economical sense to use the fully integrated version of SIMATIC PDM for a system that only has 100 inputs and outputs. Engineering and maintenance functions are accessible through the connections to HART, FOUNDATION Fieldbus, PROFIBUS PA and PROFIBUS DP devices that can be connected to a SIMATIC PCS 7 BOX RTX ES/OS system.

Single-user system (single station)

When using a single-user system, PDM connects to field devices via the Ethernet system bus and the routing functionality of the automation system.

Client/server system

PDM is installed in the Engineering System of medium to large system configurations, with or without a redundant server, and connected to field devices over the Ethernet system bus and the routing functionality of the automation system.

Non-SIMATIC S7 master

Non-PCS 7 PROFIBUS DP master can use the Ethernet to PROFIBUS DP (IE/PB Link) interfaces, which allow a seamless connection to lower-level field devices. By integrating PDM into STEP 7, more field devices can be managed comprehensively and their data can be archived and versioned just like in SIMATIC PCS 7.

SIMATIC MS PDM

The SIMATIC Maintenance Station PDM is a single-user system based on Microbox which can be used both in the PCS 7 environment and in any automation system that uses PROFIBUS communication. SIMATIC MS PDM works autonomously, i.e. independent from the automation projects and automation systems (controllers). SIMATIC MS PDM uses PDM-supported types of communication to exchange information with field devices. The connection of the Maintenance Station PDM with PROFIBUS streams is achieved via IE/PB links.

Note

The SIMATIC Maintenance Station PDM V1.0 is based on the system components of SIMATIC PCS 7 V7.1+SP3 (particularly PDM V6.1).

12.1 SIMATIC PDM stand-alone

Figure 12-1

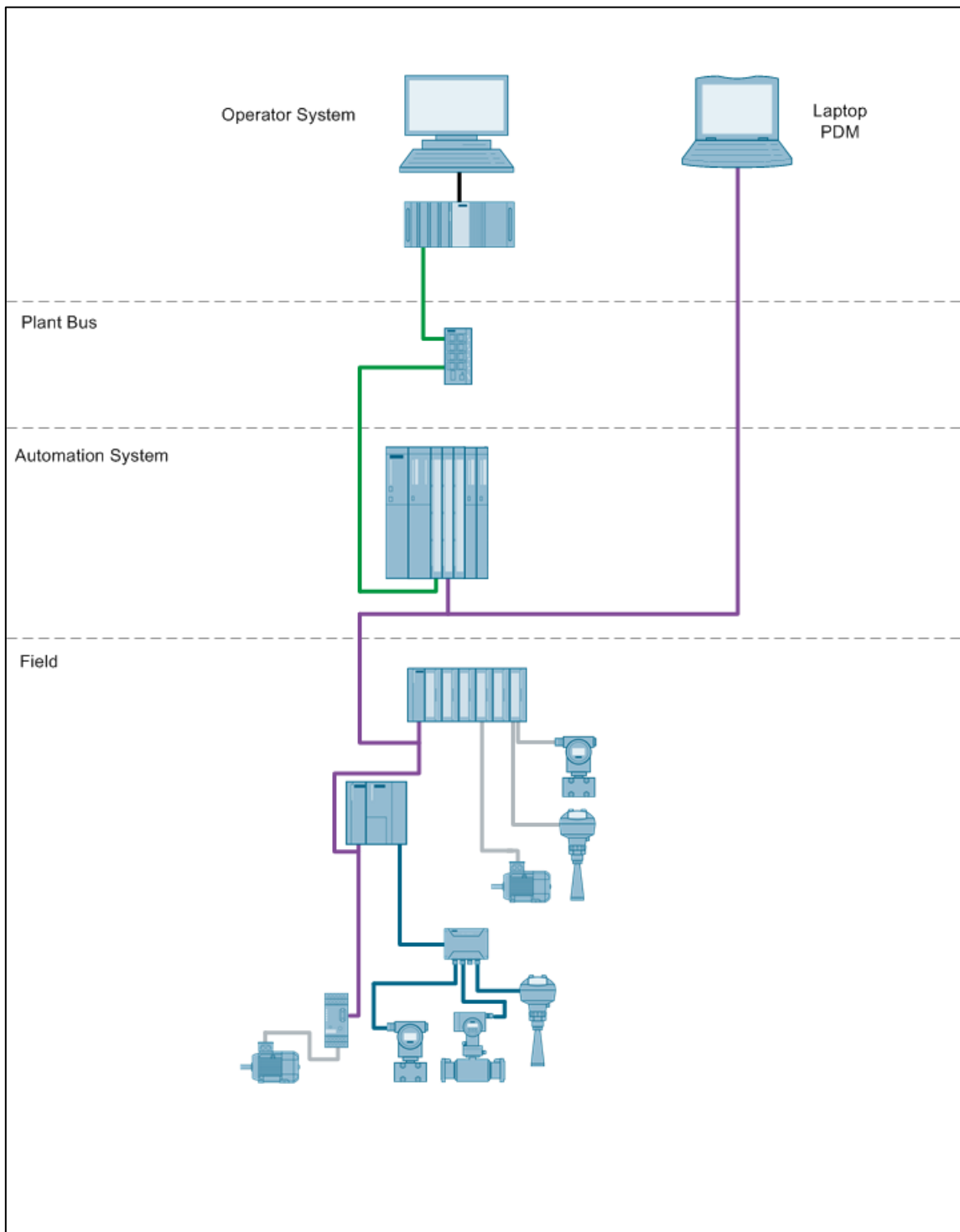

Bill of material for the SIMATIC PDM stand-alone system

Table 12-1

Required	Optional	Product number	Product description	Note
Laptop PDM				
1		6ES7 972-0CB20-0XA0	SIMATIC S7, PC ADAPTER USB NETWORK CARD	¹⁾
	1	6GK1 561-2AA01	CP5612 COMMUNICATION PROCESSOR PCI CARD (32 BIT / 64 BIT)	¹⁾
1		6ES7658-3AB18-0YA5	SOFTWARE SIMATIC PDM BASIC V8.1 (4 TAGs)	²⁾

Note

The SIMATIC PCS 7 single-user system is not listed.

¹⁾ USB network card for laptop use. Use CP5612 (or other approved network cards) for desktop PC systems.

²⁾ The number of TAGs can be increased by means of cumulative TAG licenses.

12.2 SIMATIC PDM with SIMATIC Field PG at the system bus

Figure 12-2

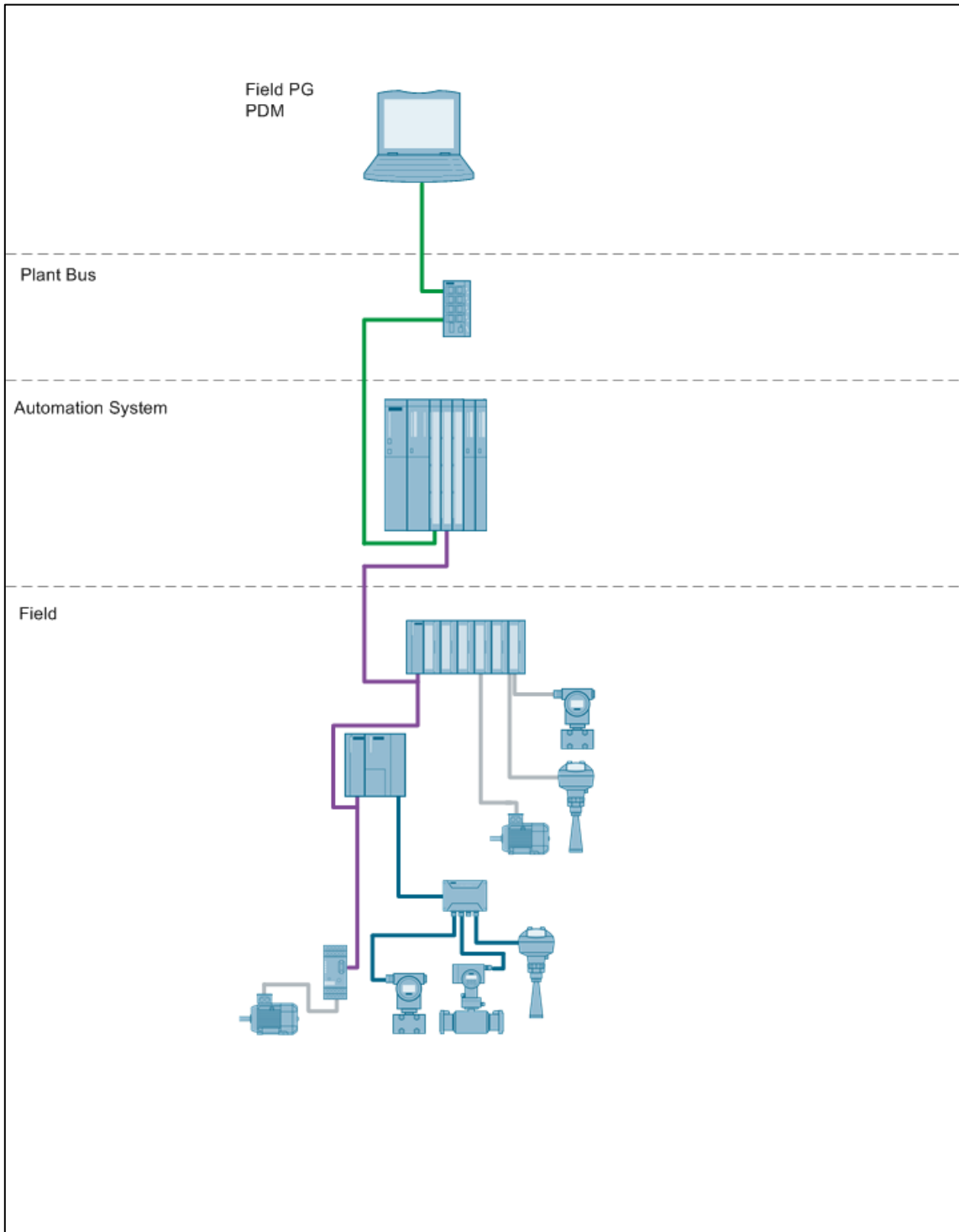

Bill of material for SIMATIC PDM with SIMATIC Field PG at the system bus

Table 12–2

Required	Optional	Product number	Product description	Note
Laptop PDM				
1		6ES7658-3JD18-0YA5	SOFTWARE SIMATIC PDM SERVICE V8.1 (100 TAGs)	¹⁾
1		6ES7658-3CX16-2YB5	SOFTWARE SIMATIC PDM ROUTING S7-400 V6.1	

NOTICE This configuration can also be used by service laptops. However, these must have an Ethernet network card that supports the ISO protocol (MAC addresses).

Note ¹⁾ The number of TAGs can be increased by means of cumulative TAG licenses.

12.3 SIMATIC PDM and PCS 7 Starter System

Figure 12-3

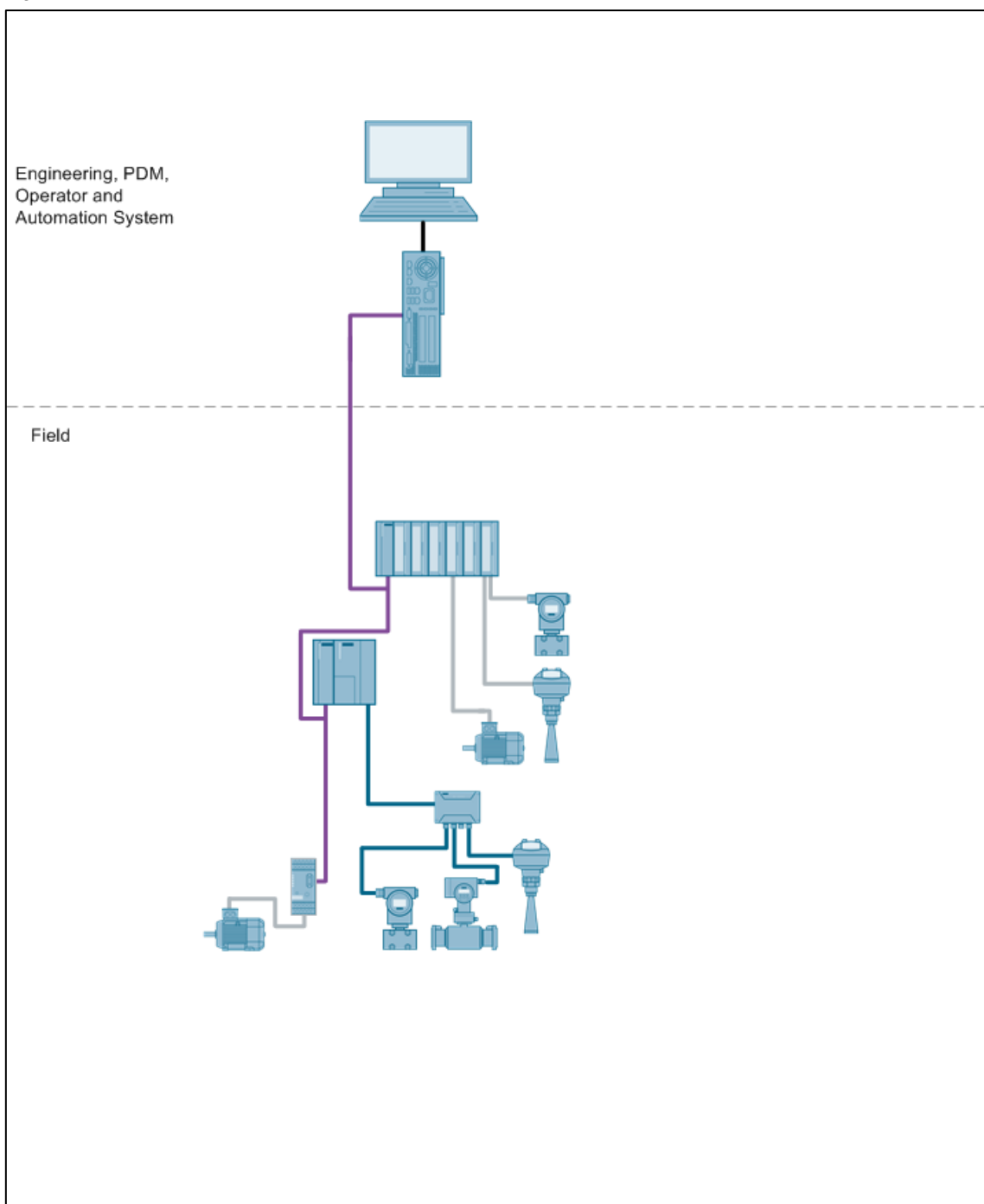

Bill of material for SIMATIC PDM and PCS 7 Starter System

Table 12-3

Required	Optional	Product number	Product description	Note
Engineering, PDM, operator and automation system				
1		6ES7650-4AA11-0GA0	SIMATIC PCS 7 BOX RTX V8.0 SP1 ALL-IN-ONE SYSTEM (ES, OS AND AS)	1) 3)
1		6ES7 648-0CB00-0YA0	SIMATIC PC KEYBOARD GERMAN / NTERNATIONAL USB INTERFACE	
	1	6ES7 652-0XD08-2YB5	SOFTWARE SIMATIC PCS 7 SFC VISUALIZATION V8.0	
	1	6ES7 658-1CX17-2YA5	SOFTWARE SIMATIC PCS 7 VERSION CROSS MANAGER V7.1	
	1	6ES7 658-1DX08-2YB5	SOFTWARE SIMATIC PCS 7 IMPORT EXPORT ASSISTANT V8.0	
	1	6ES7 658-1FX08-2YA5	SOFTWARE SIMATIC PCS 7 VERSION TRAIL V8.0	
1		6ES7 658-3LD08-0YA5	SOFTWARE SIMATIC PDM PCS 7 V8.1 (100 TAG)	2)
	1	6ES7 658-3QX18-2YB5	SOFTWARE SIMATIC PDM Communication FOUNDATION Fieldbus V8.1	3) 2)

Note

- 1) Please use the PCS 7 BOX configurator, as the PCS 7 BOX is available in different versions, e.g. 24V DC or 110/230V AC.
- 2) The number of TAGs can be increased by means of cumulative TAG licenses.
- 3) Optional for FOUNDATION Fieldbus communication

12.4 SIMATIC PDM and PCS 7 Single-user System

Figure 12-4

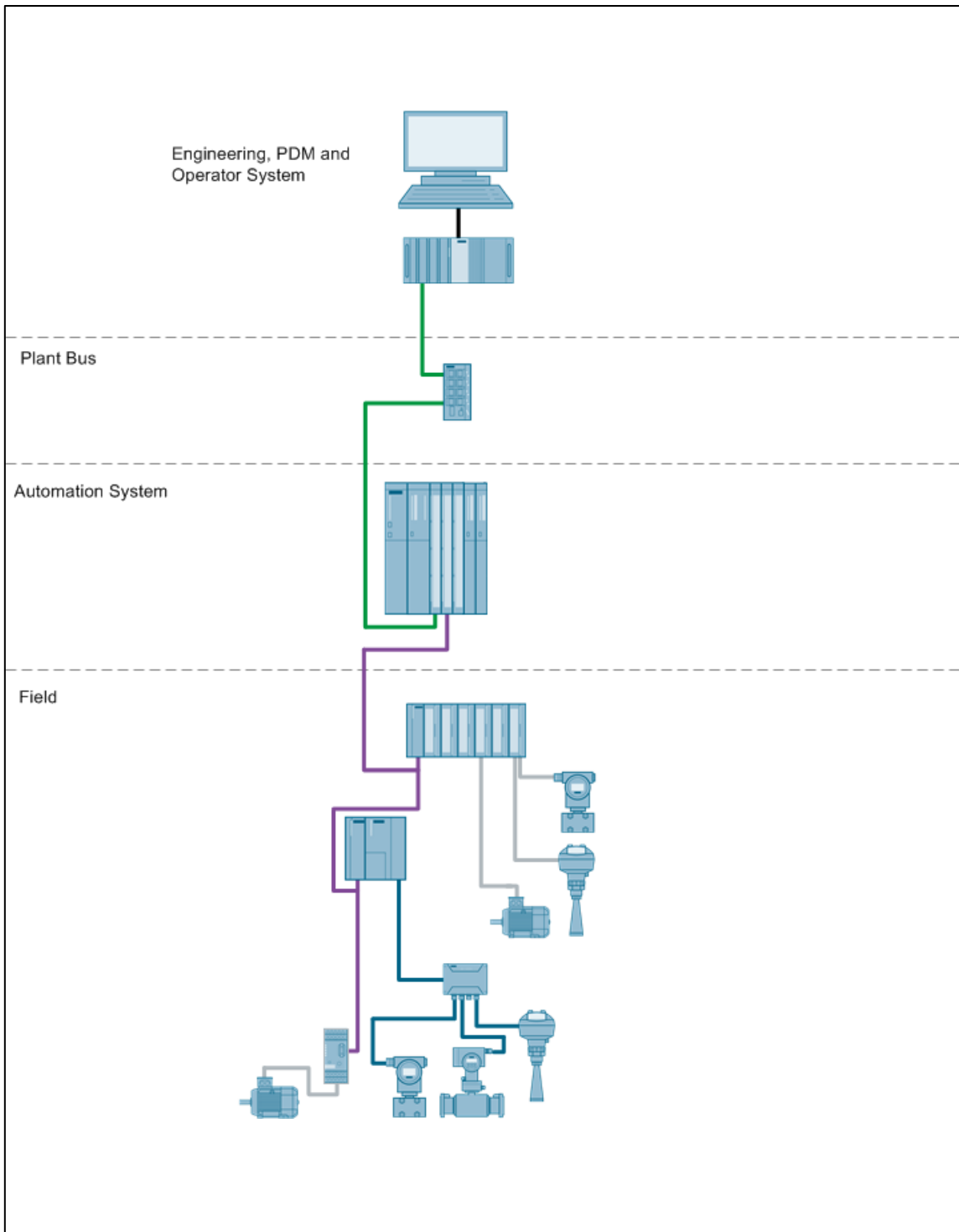

Bill of material for SIMATIC PDM and PCS 7 Single-user station

Table 12–4

Required	Optional	Product number	Product description	Note
Engineering System, PDM and Operator System				
1		6ES7660-2AA30-1CA0	SIMATIC PCS 7 INDUSTRIAL WORKSTATION IPC847C, CORE I7, ES/OS SINGLESTATION, RAID1 (500GB INTERNAL), 8GB DDR3, BCE, PCS 7 V8.0 SP1, WIN 7	
1		6ES7 658-5AX08-0YA5	SOFTWARE SIMATIC PCS 7 AS/OS ENGINEERING V8.0	
1		6ES7 658-2AA08-0YA0	SOFTWARE SIMATIC PCS 7 OS SOFTWARE SINGLE STATION V8.0 (PO 100)	1)
	1	6ES7 652-0XD08-2YB5	SOFTWARE SIMATIC PCS 7 SFC VISUALIZATION V8.0	
	1	6ES7 658-1CX17-2YA5	SOFTWARE SIMATIC PCS 7 VERSION CROSS MANAGER V7.1	
	1	6ES7 658-1DX08-2YB5	SOFTWARE SIMATIC PCS 7 IMPORT EXPORT ASSISTANT V8.0	
	1	6ES7 658-1FX08-2YA5	SOFTWARE SIMATIC PCS 7 VERSION TRAIL V8.0	
1		6ES7 658-3LD08-0YA5	SOFTWARE SIMATIC PDM PCS 7 V8.1 (100 TAG)	4)
	1	6ES7658-3QX18-2YB5	SOFTWARE SIMATIC PDM Communication FOUNDATION Fieldbus V8.1	5)
System bus				
1		6GK5 208-0BA10-2AA3	SIMATIC NET SCALANCE X208, MANAGED IE SWITCH, 8 X 10/100MBIT/S	2)
2		6XV1 870-3QH60	SIMATIC NET INDUSTRIAL ETHERNET TP CORD CABLE RJ45/RJ45, 6M	
Automation system				
1		6ES7 654-6CL03-3BF0	SIMATIC PCS 7 SINGLE AS, CPU 410-5H, 1X DP-MODULE, 1x PROFINET-IO, SYSTEM EXPANSIONS CARD 500 PO, AS RT PO 100, CP443-1IE, UR2 ALU RACK, 1 X UC 120/230V 10A POWER SUPPLYSIMATIC	1) 3) 6)

Note

- 1) The number of POs can be increased later on by means of extra volume licenses.
- 2) SCALANCE switch requires a 24VDC power supply (not listed).
- 3) Please use the PCS 7 AS configurator, as the PCS 7 AS 410-5H is available in different versions, e.g. 24V DC or 110/230V AC.
- 4) The number of TAGs can be increased by means of cumulative TAG licenses.
- 5) Optional for FOUNDATION Fieldbus communication
- 6) AS412/414/417-4-1H and AS412/414/417-4-2H controllers require CP443-5 Ext PROFIBUS communication modules for PDM Data Record Routing.

12.5 SIMATIC PDM and PCS 7 client/server system

Figure 12-5

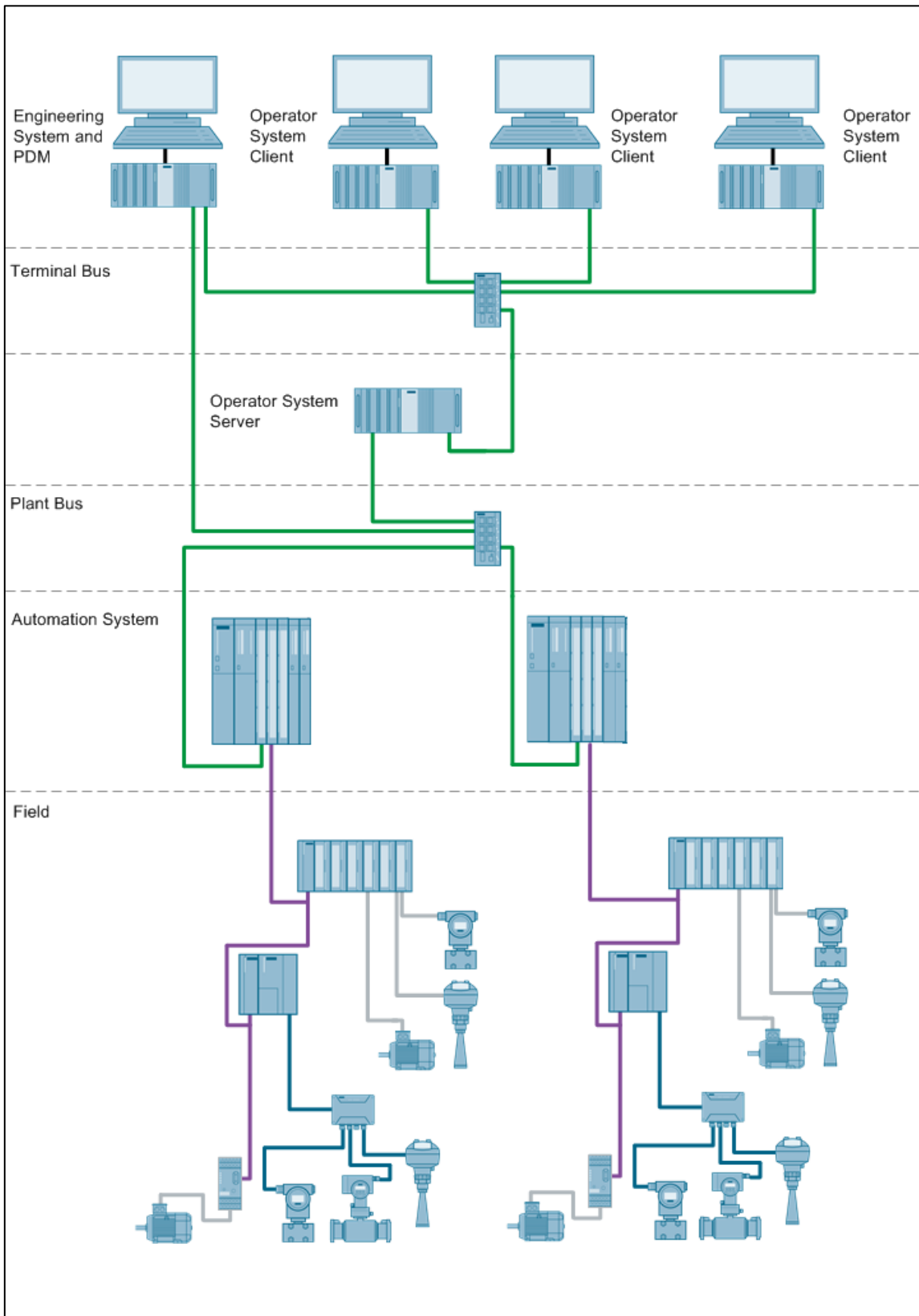

Bill of material for the SIMATIC PDM and PCS 7 client/server system

Table 12-5

Required	Optional	Product number	Product description	Note
Engineering System				
1		6ES7660-2AA30-1CA0	SIMATIC PCS 7 INDUSTRIAL WORKSTATION IPC847C, CORE I7, ES/OS SINGLESTATION, RAID1 (500GB INTERNAL), 8GB DDR3, BCE, PCS 7 V8.0 SP1, WIN 7	
1		6ES7 658-5AX08-0YA5	SOFTWARE SIMATIC PCS 7 AS/OS ENGINEERING V8.0	
	1	6ES7 658-1CX17-2YA5	SOFTWARE SIMATIC PCS 7 VERSION CROSS MANAGER V7.1	
	1	6ES7 658-1FX08-2YA5	SOFTWARE SIMATIC PCS 7 VERSION TRAIL V8.0	
	1	6ES7 658-1DX08-2YB5	SOFTWARE SIMATIC PCS 7 IMPORT EXPORT ASSISTANT V8.0	
1		6ES7658-3LD18-0YA5	SOFTWARE SIMATIC PDM PCS 7 V8.1 (100 TAG)	4)
	1	6ES7658-3QX18-2YB5	SOFTWARE SIMATIC PDM Communication FOUNDATION Fieldbus V8.1	5)
Operator System server				
1		6ES7660-2BA30-1DA0	SIMATIC PCS 7 INDUSTRIAL WORKSTATION IPC847C, CORE I7, OS SERVER, RAID1 (500GB INTERNAL), 8GB DDR3, BCE, PCS 7 V8.0 SP1, WIN SERVER 2008	
1		6ES7 658-2BA08-0YA0	SOFTWARE SIMATIC PCS 7 OS SOFTWARE SERVER V8.0 (PO 100)	1)
Operator System client				
3		6ES7660-1CA18-1CA0	SIMATIC PCS 7 INDUSTRIAL WORKSTATION IPC647C, CORE I7, OS CLIENT, 500GB INTERNAL, 4GB DDR3, PCS 7 V8.0 SP1, WIN 7	
3		6ES7 658-2CX08-0YB5	SOFTWARE SIMATIC PCS 7 OS CLIENT V8.0	
	3	6ES7 652-0XD08-2YB5	SOFTWARE SIMATIC PCS 7 SFC VISUALIZATION V8.0	

Required	Optional	Product number	Product description	Note
Terminal bus				
1		6GK5 208-0BA10-2AA3	SIMATIC NET SCALANCE X208, MANAGED IE SWITCH, 8 X 10/100MBIT/S	²⁾
5		6XV1 870-3QH60	SIMATIC NET INDUSTRIAL ETHERNET TP CORD CABLE RJ45/RJ45, 6M	
System bus				
1		6GK5 208-0BA10-2AA3	SIMATIC NET SCALANCE X208, MANAGED IE SWITCH, 8 X 10/100MBIT/S	²⁾
4		6XV1 870-3QH60	SIMATIC NET INDUSTRIAL ETHERNET TP CORD CABLE RJ45/RJ45, 6M	
Automation system				
2		6ES7 654-6CN03-3BF0	SIMATIC PCS 7 SINGLE AS, CPU 410-5H, 1X DP-MODULE, 1x PROFINET-IO, SYSTEM EXPANSIONS CARD 1000 PO, AS RT PO 100, CP443-1IE, UR2 ALU RACK, 1 X UC 120/230V 10A POWER SUPPLY SIMATIC	³⁾ ⁶⁾

Note

- ¹⁾ The number of POs can be increased later on by means of extra volume licenses.
- ²⁾ SCALANCE switch requires a 24VDC power supply (not listed).
- ³⁾ Please use the PCS 7 AS configurator, as the PCS 7 AS 410-5H is available in different versions, e.g. 24V DC or 110/230V AC.
- ⁴⁾ The number of TAGs can be increased by means of cumulative TAG licenses.
- ⁵⁾ Optional for FOUNDATION Fieldbus communication
- ⁶⁾ AS412/414/417-4-1H and AS412/414/417-4-2H controllers require CP443-5 Ext PROFIBUS communication modules for PDM Data Record Routing.

12.6 SIMATIC PDM and non-SIMATIC S7 master

Figure 12-6

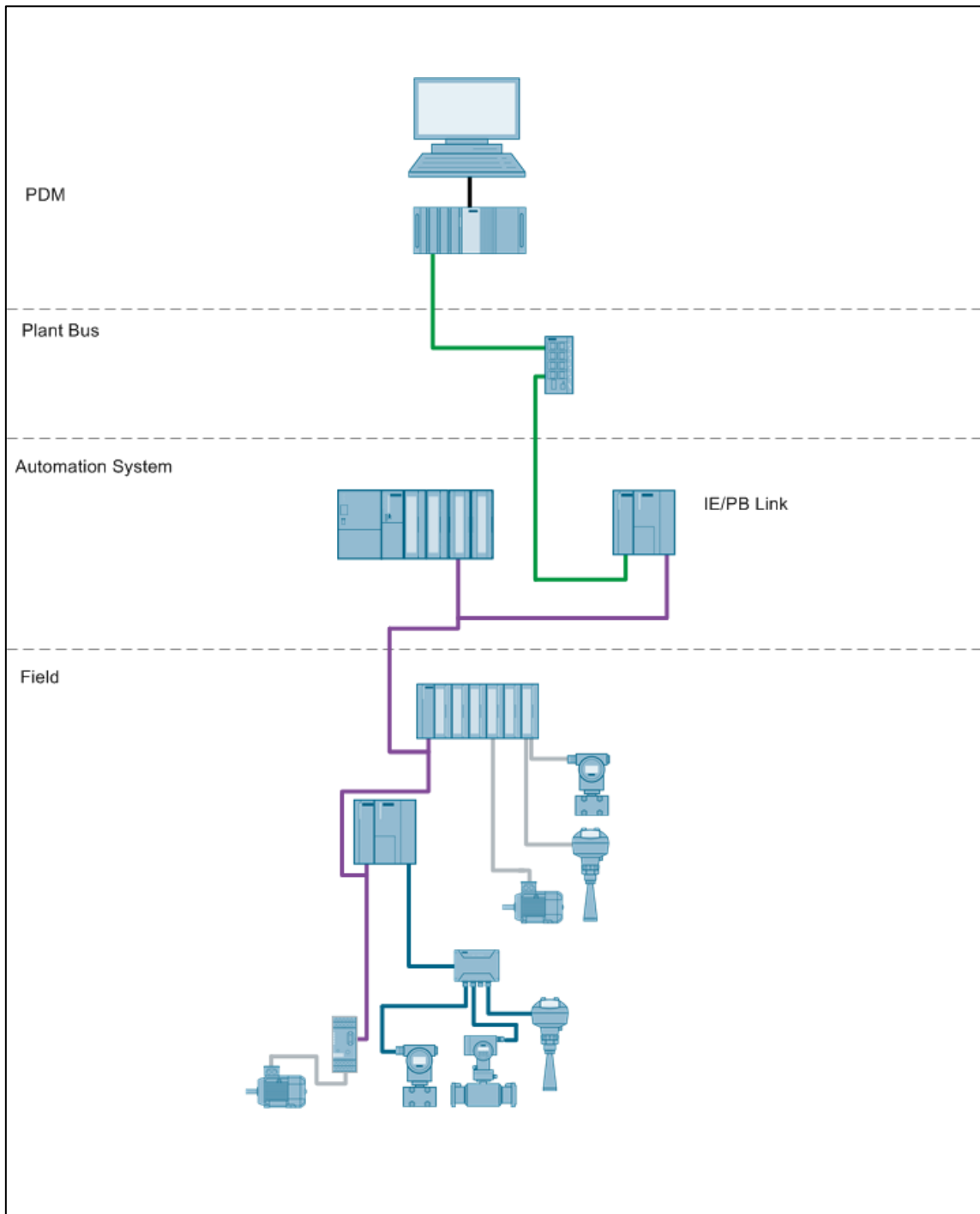

Bill of material for SIMATIC PDM and non-SIMATIC S7 master

Table 12–6

Required	Optional	Product number	Product description	Note
PDM				
1		6ES7660-2AA30-1CA0	SIMATIC PCS 7 INDUSTRIAL WORKSTATION IPC847C, CORE I7, ES/OS SINGLESTATION, RAID1 (500GB INTERNAL), 8GB DDR3, BCE, PCS 7 V8.0 SP1, WIN 7	
1		6ES7810-4CC10-0YA5	SOFTWARE SIMATIC S7 STEP7 V5.5 SP3	
	1	6ES7658-3KD18-0YA5	SOFTWARE SIMATIC PDM S7 V8.1 (100 TAGs)	3)
System bus				
1		6GK5 208-0BA10-2AA3	SIMATIC NET SCALANCE X208, MANAGED IE SWITCH, 8 X 10/100MBIT/S	1)
2		6XV1 870-3QH60	SIMATIC NET INDUSTRIAL ETHERNET TP CORD CABLE RJ45/RJ45, 6M	
1		6GK1 411-5AB00	IE/PB-Link PN IO NETWORK TRANSITION BETWEEN IND. ETHERNET UND PROFIBUS	2)

Note

- 1) SCALANCE switch requires a 24VDC power supply (not listed).
- 2) The IE/PB module requires a 24VDC power supply (not listed).
- 3) The number of TAGs can be increased by means of cumulative TAG licenses.

12.7 SIMATIC MS PDM

Figure 12–8

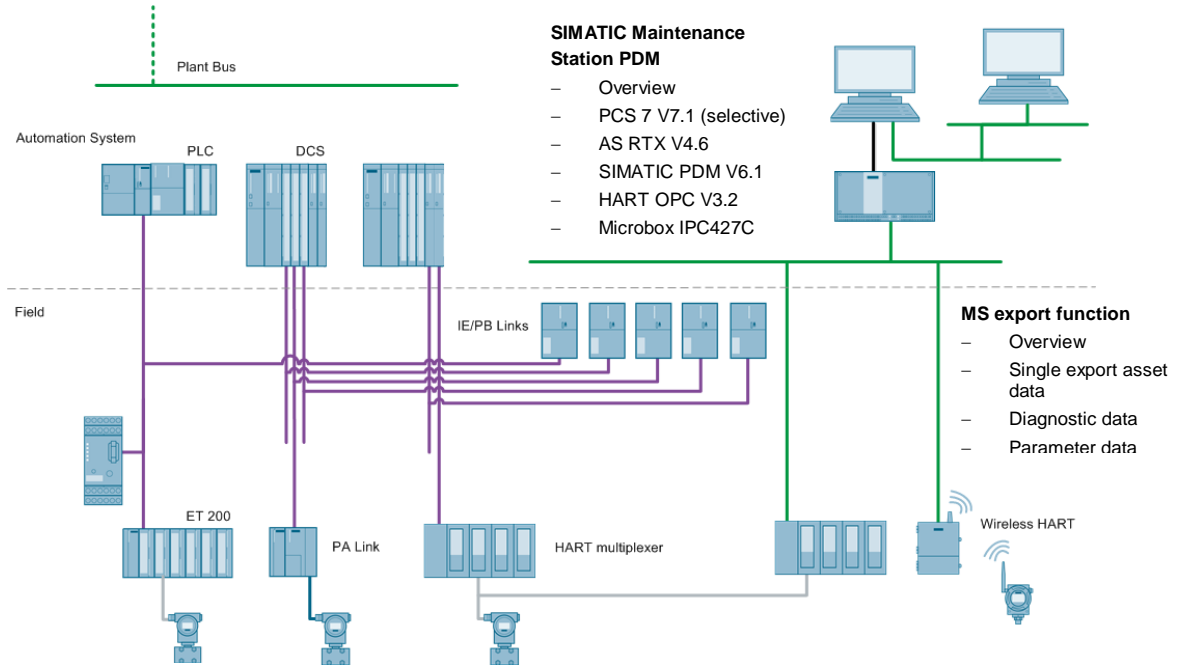

Bill of material for SIMATIC MS PDM

Table 12–8

Required	Optional	Product number	Product description	Note
PDM				
1		6ES7 650-0RJ01-0YX0	SIMATIC MAINTENANCE STATION PDM V1.0 (100 TAG), CORE2 DUO, 250 GB HDD, 2X ETHERNET RJ45, CP 5611, WIN XP PROF. MUI, PDM V6.1	1) 2) 3) 4)
5		6GK1 411-5AB00	IE/PB-Link PN IO NETWORK TRANSITION BETWEEN IND. ETHERNET UND PROFIBUS	5)

Note

- 1) Only the configuration for the SIMATIC PDM Maintenance Station is listed.
- 2) The number of PDM TAGs can be increased by means of PowerPacks.
- 3) The number of Asset TAGs can be increased by means of TAG expansions.
- 4) The number of process objects (PO) can be increased by means of PowerPacks.
- 5) The IE/PB module requires a 24VDC power supply (not listed).

13 Asset management

SIMATIC PCS 7 Asset Management

The functionality of SIMATIC PCS 7 asset management provides the operator with comprehensive diagnostic and maintenance information, at any time, is fully integrated in the Operator System and contains complete system information on one Maintenance Station.

The diagnostics screens structured according to the process cell hierarchy with the operating states of the SIMATIC PCS 7 components can be displayed on the SIMATIC PCS 7 Maintenance Station and also on the OS clients. More detailed diagnostic information determined by SIMATIC PDM is also displayed on the faceplates of these stations. However, enhanced online diagnostics functions in conjunction with HW Config can only be launched from the SIMATIC PCS 7 Maintenance Station.

Starter System

The SIMATIC PCS 7 BOX RTX system supports the full asset management functionality of the integrated automation system, the PC station and all connected field devices.

Single-user station

ES, OS and asset management functions are connected to the single-user station via the Ethernet system bus. Asset Management provides diagnostic and maintenance data of the automation system, the PC station, the active networking components and all connected field devices.

Client/server (redundant)

In a client/server architecture, the asset management system is modeled on the distributed client/server structure in SIMATIC PCS 7. The asset management system uses standard condition codes and messages from the PCS 7 OS. The maintenance server is based on an OS server. It can be realized as a combined OS/MS server (= on an existing OS server) or as a separate MS server.

The OS clients can access maintenance pictures in PCS 7 just like standard process images. These maintenance pictures include additional information for detailed diagnostics and troubleshooting of intelligent field devices.

13.1 Asset Management Starter System

Figure 13-1

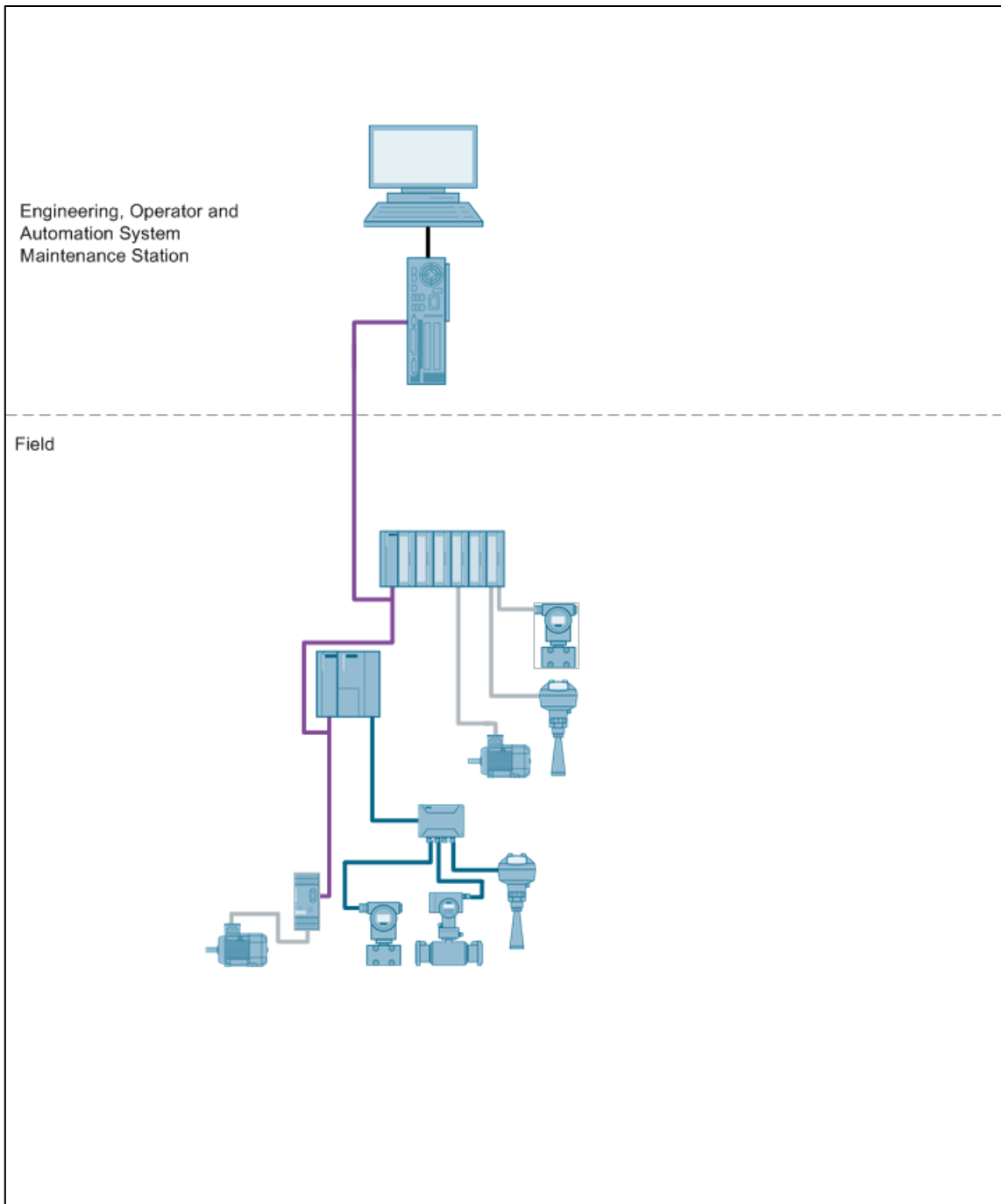

Bill of material for the Asset Management Starter System

Table 13–1

Required	Optional	Product number	Product description	Note
Engineering, operator and automation system				
1		6ES7650-4AA11-0GA0	SIMATIC PCS 7 BOX RTX V8.0 SP1 ALL-IN-ONE SYSTEM (ES, OS AND AS)	¹⁾
1		6ES7 658-7GB08-0YB0	SOFTWARE SIMATIC PCS 7 Maintenance Station Runtime Basic Package V8.0 (incl. SNMP-OPC server license and 100 Asset TAGs)	²⁾
	1	6ES7 652-0XD08-2YB5	SOFTWARE SIMATIC PCS 7 SFC VISUALIZATION V8.0	
	1	6ES7 658-1CX17-2YA5	SOFTWARE SIMATIC PCS 7 VERSION CROSS MANAGER V7.1	
	1	6ES7 658-1DX08-2YB5	SOFTWARE SIMATIC PCS 7 IMPORT EXPORT ASSISTANT V8.0	
	1	6ES7 658-1FX08-2YA5	SOFTWARE SIMATIC PCS 7 VERSION TRAIL V8.0	
1		6ES7 658-7GX08-0YB5	SOFTWARE SIMATIC PDM PCS 7 V8.1 (100 TAG)	³⁾
1		6ES7 658-7GX08-0YB5	SIMATIC PCS 7 Maintenance Station Engineering V8.0	
	1	6ES7 658-3QX18-2YB5	SOFTWARE SIMATIC PDM Communication FOUNDATION Fieldbus V8.1	⁴⁾

Note

Asset management does not necessarily need PDM, as it is rather optional!
PDM is useful when operating intelligent field devices or when using Assetmon modules (for the integration of non-intelligent devices in Asset Management).

Note

- ¹⁾ Please use the PCS 7 BOX configurator, as the PCS 7 BOX is available in different versions, e.g. 24V DC or 110/230V AC.
²⁾ The number of Asset TAGs can be increased by means of cumulative Asset TAG licenses.
³⁾ The number of TAGs can be increased by means of cumulative TAG licenses.
⁴⁾ Optional for FOUNDATION Fieldbus communication.

13.2 Asset Management Single-user station

Figure 13-2

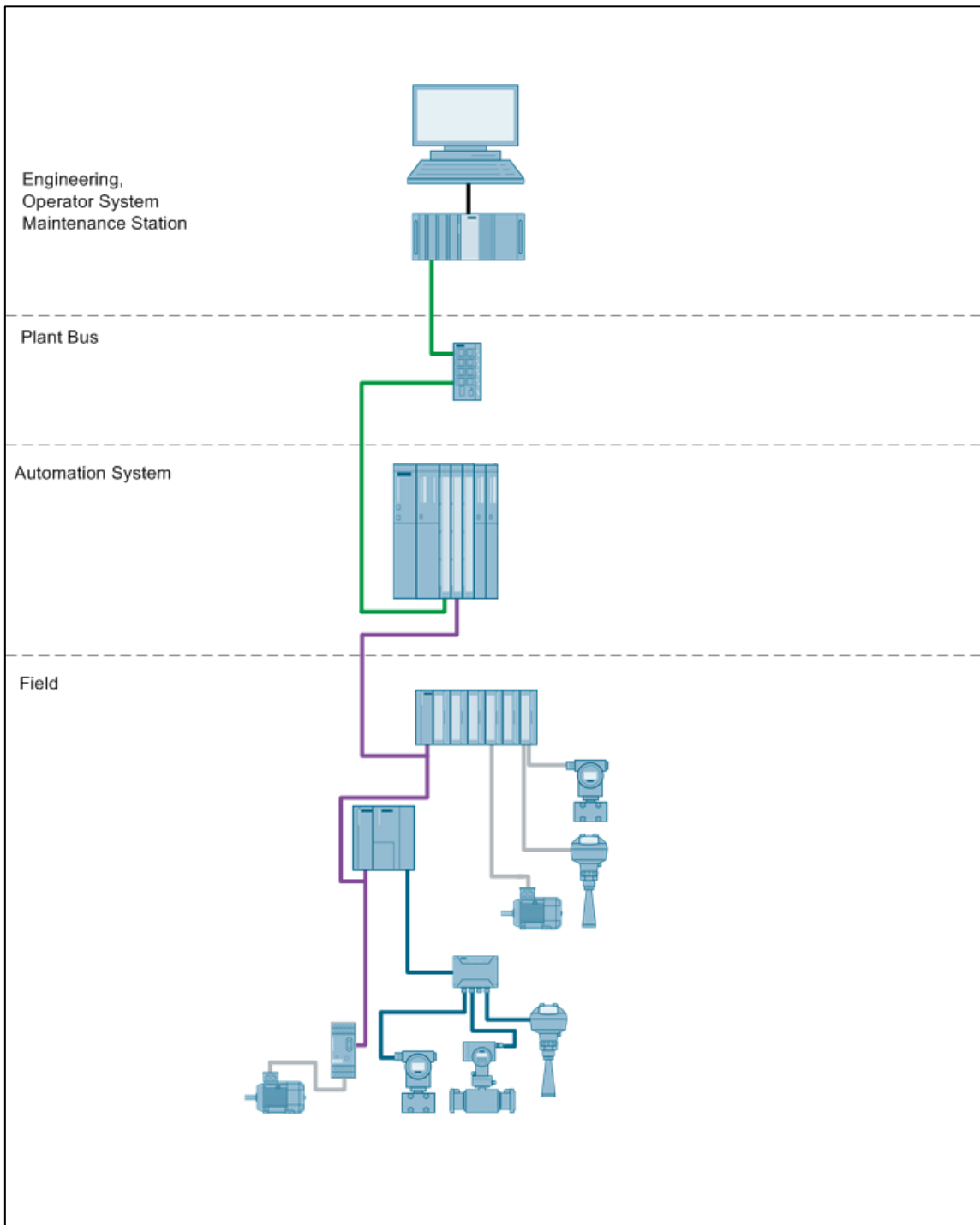

Bill of material for asset management single-user station

Table 13–2

Required	Optional	Product number	Product description	Note
Engineering System, PDM and Operator System				
1		6ES7660-2AA30-1CA0	SIMATIC PCS 7 INDUSTRIAL WORKSTATION IPC847C, CORE I7, ES/OS SINGLESTATION, RAID1 (500GB INTERNAL), 8GB DDR3, BCE, PCS 7 V8.0 SP1, WIN 7	
1		6ES7 658-5AX08-0YA5	SOFTWARE SIMATIC PCS 7 AS/OS ENGINEERING V8.0	
1		6ES7 658-2AA08-0YA0	SOFTWARE SIMATIC PCS 7 OS SOFTWARE SINGLE STATION V8.0 (PO 100)	1)
	1	6ES7 652-0XD08-2YB5	SOFTWARE SIMATIC PCS 7 SFC VISUALIZATION V8.0	
	1	6ES7 658-1CX17-2YA5	SOFTWARE SIMATIC PCS 7 VERSION CROSS MANAGER V7.1	
	1	6ES7 658-1DX08-2YB5	SOFTWARE SIMATIC PCS 7 IMPORT EXPORT ASSISTANT V8.0	
	1	6ES7 658-1FX08-2YA5	SOFTWARE SIMATIC PCS 7 VERSION TRAIL V8.0	
1		6ES7 658-3LD08-0YA5	SOFTWARE SIMATIC PDM PCS 7 V8.1 (100 TAG)	4)
1		6ES7 658-7GB08-0YB0	SOFTWARE SIMATIC PCS 7 Maintenance Station Runtime Basic Package V8.0 (incl. SNMP-OPC server license and 100 Asset TAGs)	5)
1		6ES7 658-7GX08-0YB5	SIMATIC PCS 7 Maintenance Station Engineering V8.0ASSET	
	1	6ES7 658-3QX18-2YB5	SOFTWARE SIMATIC PDM Communication FOUNDATION Fieldbus V8.1	6)
System bus				
1		6GK5 208-0BA10-2AA3	SIMATIC NET SCALANCE X208, MANAGED IE SWITCH, 8 X 10/100MBIT/S	2)
2		6XV1 870-3QH60	SIMATIC NET INDUSTRIAL ETHERNET TP CORD CABLE RJ45/RJ45, 6M	
Automation system				
1		6ES7 654-6CL03-3BF0	SIMATIC PCS 7 SINGLE AS, CPU 410-5H, 1X DP-MODULE, 1x PROFINET-IO, SYSTEM EXPANSIONS CARD 500 PO, AS RT PO 100, CP443-1IE, UR2 ALU RACK, 1 X UC 120/230V 10A POWER SUPPLYSIMATIC	1) 3)

Note

- ¹⁾ The number of POs can be increased later on by means of extra volume licenses.
- ²⁾ SCALANCE switch requires a 24VDC power supply (not listed).
- ³⁾ Please use the PCS 7 AS configurator, as the PCS 7 AS 410-5H is available in different versions, e.g. 24V DC or 110/230V AC.
- ⁴⁾ The number of TAGs can be increased by means of cumulative TAG licenses.⁵⁾ The number of Asset TAGs can be increased by means of cumulative Asset TAG licenses.
- ⁶⁾ Optional for FOUNDATION Fieldbus communication

Sample invoice with asset management single-user station

The following is a sample invoice with asset management tags, process objects and PDM tags for a given single-user configuration.

The single-user configuration consists of the following:

- an ES/OS/MS single-user station
- 200 PROFIBUS PA sensors and actuators
- 100 HART analog sensors and actuators
- 32 FOUNDATION Fieldbus H1 sensors and actuators
- 8 ET200M IO racks, total of 50 IO modules
- 80 PROFIBUS DP slaves with EDDL configuration
- 25 PROFIBUS DP slaves without EDDL configuration
- 1 AS 410-5H
- 5 PROFIBUS DP and PA networking segments
- Single plant bus, one switch
- Single terminal bus, one switch
- 120 process devices with asset monitoring functionality

The following is needed for the above mentioned configuration:

Table 13–3

Element	Count value	Asset Management tags	Process objects	PDM tags
Computer	1	1	0	0
PROFIBUS PA	200	200	0	200
HART	100	100	0	100
FOUNDATION Fieldbus H1	32	32	0	32
ET200M IM bus interface	8	8	0	0
ET200M module	50	0	0	0
PROFIBUS DP slaves - EDDL	80	80	0	80
PROFIBUS DP slaves - without EDDL	25	25	0	0

Element	Count value	Asset Management tags	Process objects	PDM tags
Automation system	1	1	0	0
System bus switches	1	1	0	0
Terminal bus switches	1	1	0	0
Networks	7	0	0	0
Process devices	120	120	120	120
Totals				
		569	120	531

Bill of material for the asset management single-user station, based on the sample invoice

Table 13–4

Required	Optional	Product number	Product description	Note
Engineering System, PDM and Operator System				
1		6ES7660-2AA30-1CA0	SIMATIC PCS 7 INDUSTRIAL WORKSTATION IPC847C, CORE I7, ES/OS SINGLESTATION, RAID1 (500GB INTERNAL), 8GB DDR3, BCE, PCS 7 V8.0 SP1, WIN 7	
1		6ES7 658-5AX08-0YA5	SOFTWARE SIMATIC PCS 7 AS/OS ENGINEERING V8.0	
1		6ES7 658-2AA08-0YA0	SOFTWARE SIMATIC PCS 7 OS SOFTWARE SINGLE STATION V8.0 (PO 100)	1)
1		6ES7 652-0XD08-2YB5	SOFTWARE SIMATIC PCS 7 SFC VISUALIZATION V8.0	
1		6ES7 658-1CX17-2YA5	SOFTWARE SIMATIC PCS 7 VERSION CROSS MANAGER V7.1	
1		6ES7 658-1DX08-2YB5	SOFTWARE SIMATIC PCS 7 IMPORT EXPORT ASSISTANT V8.0	
1		6ES7 658-1FX08-2YA5	SOFTWARE SIMATIC PCS 7 VERSION TRAIL V8.0	
1		6ES7 658-3LD08-0YA5	SOFTWARE SIMATIC PDM PCS 7 V8.1 (100 TAG)	4)
5		6ES7 658-3XC00-2YB5	SIMATIC PDM 10 TAGs	4)
5		6ES7 658-3XD00-2YB5	SIMATIC PDM 100 TAGs	4)
1		6ES7658-3QX18-2YB5	SOFTWARE SIMATIC PDM Communication FOUNDATION Fieldbus V8.1	6)
1		6ES7 658-7GB08-0YB0	SOFTWARE SIMATIC PCS 7 Maintenance Station Runtime Basic Package V8.0 (incl. SNMP-OPC server license and 100 Asset TAGs)	5)
1		6ES7 658-7GX08-0YB5	SIMATIC PCS 7 Maintenance Station Engineering V8.0	
5		6ES7 658-7GB00-2YB0	100 ASSET TAGS	5)

Required	Optional	Product number	Product description	Note
System bus				
1		6GK5 208-0BA10-2AA3	SIMATIC NET SCALANCE X208, MANAGED IE SWITCH, 8 X 10/100MBIT/S	2)
2		6XV1 870-3QH60	SIMATIC NET INDUSTRIAL ETHERNET TP CORD CABLE RJ45/RJ45, 6M	
Automation system				
1		6ES7 654-6CL03-3BF0	SIMATIC PCS 7 SINGLE AS, CPU 410-5H, 1X DP-MODULE, 1x PROFINET-IO, SYSTEM EXPANSIONS CARD 500 PO, AS RT PO 100, CP443-1IE, UR2 ALU RACK, 1 X UC 120/230V 10A POWER SUPPLYSIMATIC	1) 3)

Note

- 1) The number of POs can be increased later on by means of extra volume licenses.
- 2) SCALANCE switch requires a 24VDC power supply (not listed).
- 3) Please use the PCS 7 AS configurator, as the PCS 7 AS 410-5H is available in different versions, e.g. 24V DC or 110/230V AC.
- 4) The number of TAGs can be increased by means of cumulative TAG licenses in steps of 10/100/1000.
- 5) The number of Asset TAGs can be increased by means of cumulative Asset TAG licenses.
- 6) Optional for FOUNDATION Fieldbus communication⁴⁴

13.3 Asset Management Client/server

Figure 13-3

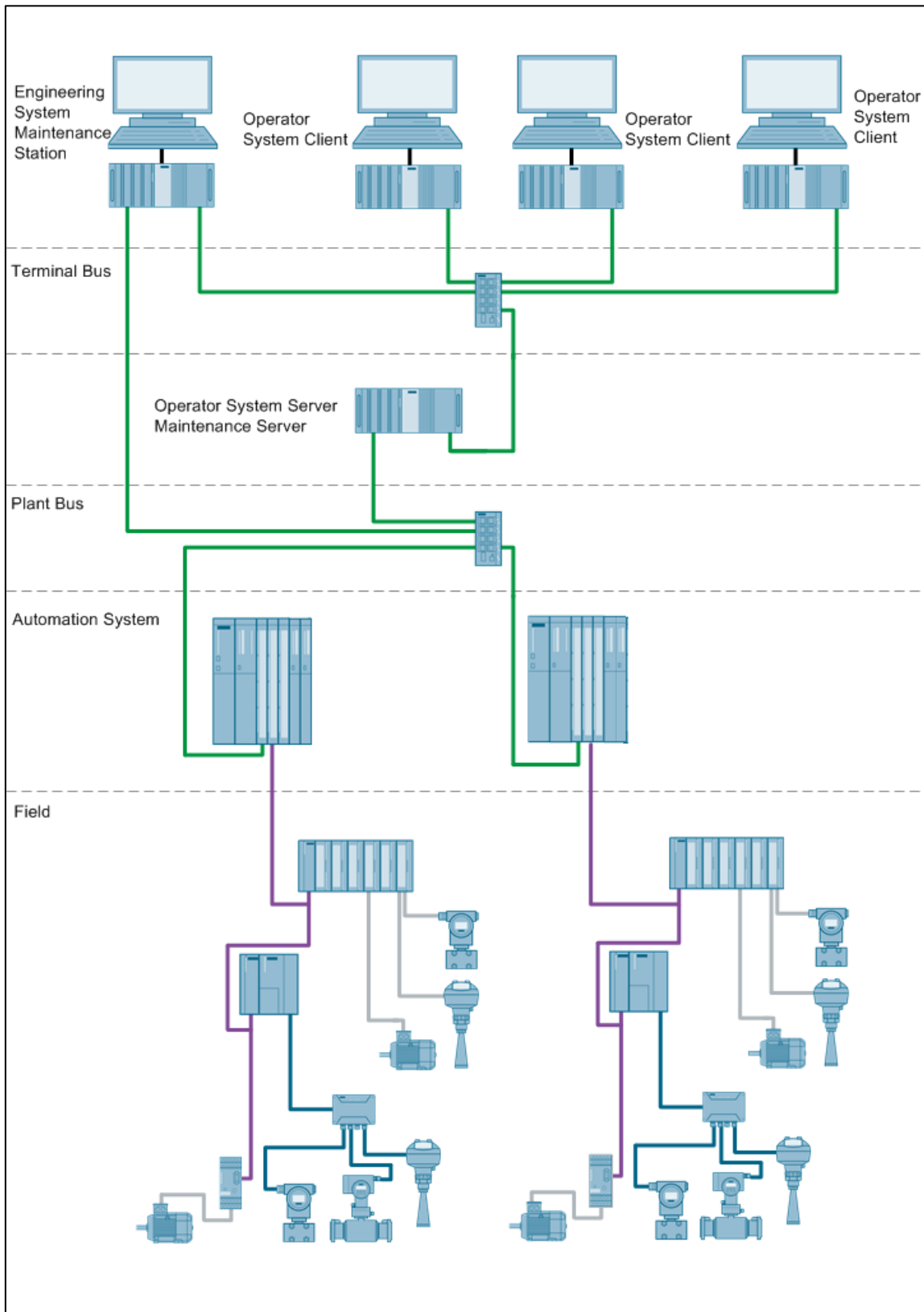

Copyright © Siemens AG 2013 All rights reserved

Bill of material for the Asset Management client/server architecture

Table 13–5

Required	Optional	Product number	Product description	Note
Engineering System				
1		6ES7660-2AA30-1CA0	SIMATIC PCS 7 INDUSTRIAL WORKSTATION IPC847C, CORE I7, ES/OS SINGLESTATION, RAID1 (500GB INTERNAL), 8GB DDR3, BCE, PCS 7 V8.0 SP1, WIN 7	
1		6ES7 658-5AX08-0YA5	SOFTWARE SIMATIC PCS 7 AS/OS ENGINEERING V8.0	
	1	6ES7 652-0XD08-2YB5	SOFTWARE SIMATIC PCS 7 SFC VISUALIZATION V8.0	
	1	6ES7 658-1CX17-2YA5	SOFTWARE SIMATIC PCS 7 VERSION CROSS MANAGER V7.1	
	1	6ES7 658-1FX08-2YA5	SOFTWARE SIMATIC PCS 7 VERSION TRAIL V8.0	
	1	6ES7 658-1DX08-2YB5	SOFTWARE SIMATIC PCS 7 IMPORT EXPORT ASSISTANT V8.0	
1		6ES7 658-3LD08-0YA5	SOFTWARE SIMATIC PDM PCS 7 V8.1	4)
	1	6ES7 658-3QX18-2YB5	SOFTWARE SIMATIC PDM Communication FOUNDATION Fieldbus V8.1	6)
1		6ES7 658-7GX08-0YB5	SIMATIC PCS 7 Maintenance Station Engineering V8.0	
1		6ES7 658-2CX08-0YB5	SOFTWARE SIMATIC PCS 7 OS CLIENT V8.0	
Operator System server maintenance server				
1		6ES7660-2BA30-1DA0	SIMATIC PCS 7 INDUSTRIAL WORKSTATION IPC847C, CORE I7, OS SERVER, RAID1 (500GB INTERNAL), 8GB DDR3, BCE, PCS 7 V8.0 SP1, WIN SERVER 2008	
1		6ES7 658-2BA08-0YA0	SOFTWARE SIMATIC PCS 7 OS SOFTWARE SERVER V8.0 (PO 100)	1)
1		6ES7 658-7GB08-0YB0	SOFTWARE SIMATIC PCS 7 Maintenance Station Runtime Basic Package V8.0 (incl. SNMP-OPC server license and 100 Asset TAGs)	5)
Operator System client				
3		6ES7660-1CA18-1CA0	SIMATIC PCS 7 INDUSTRIAL WORKSTATION IPC647C, CORE I7, OS CLIENT, 500GB INTERNAL, 4GB DDR3, PCS 7 V8.0 SP1, WIN 7	
3		6ES7 658-2CX08-0YB5	SOFTWARE SIMATIC PCS 7 OS CLIENT V8.0	
	3	6ES7 652-0XD08-2YB5	SOFTWARE SIMATIC PCS 7 SFC VISUALIZATION V8.0	

Required	Optional	Product number	Product description	Note
Terminal bus				
1		6GK5 208-0BA10-2AA3	SIMATIC NET SCALANCE X208, MANAGED IE SWITCH, 8 X 10/100MBIT/S	²⁾
5		6XV1 870-3QH60	SIMATIC NET INDUSTRIAL ETHERNET TP CORD CABLE RJ45/RJ45, 6M	
System bus				
1		6GK5 208-0BA10-2AA3	SIMATIC NET SCALANCE X208, MANAGED IE SWITCH, 8 X 10/100MBIT/S	²⁾
4		6XV1 870-3QH60	SIMATIC NET INDUSTRIAL ETHERNET TP CORD CABLE RJ45/RJ45, 6M	
Automation system				
2		6ES7 654-6CN03-3BF0	SIMATIC PCS 7 SINGLE AS, CPU 410-5H, 1X DP-MODULE, 1x PROFINET-IO, SYSTEM EXPANSIONS CARD 1000 PO, AS RT PO 100, CP443-1IE, UR2 ALU RACK, 1 X UC 120/230V 10A POWER SUPPLY	³⁾

Note

- ¹⁾ The number of POs can be increased later on by means of extra volume licenses.
- ²⁾ SCALANCE switch requires a 24VDC power supply (not listed).
- ³⁾ Please use the PCS 7 AS configurator, as the PCS 7 AS 410-5H is available in different versions, e.g. 24V DC or 110/230V AC.
- ⁴⁾ The number of TAGs can be increased by means of cumulative TAG licenses.
- ⁵⁾ The number of Asset TAGs can be increased by means of cumulative Asset TAG licenses
- ⁶⁾ Optional for FOUNDATION Fieldbus communication

Sample invoice for the asset management client/server

The following is a sample invoice for the number of asset management tags, process objects and PDM tags for a given client/server configuration.

The client/server configuration includes:

- one ES/OS/MS client PC
- one OS/MS server
- three OS clients
- 300 PROFIBUS PA sensors and actuators
- 180 HART analog sensors and actuators

- 80 FOUNDATION Fieldbus H1 sensors and actuators
- 20 ET200M IO racks, total of 135 IO modules
- 160 PROFIBUS DP slaves with EDDL configuration
- 60 PROFIBUS DP slaves without EDDL configuration
- 2 AS 410-5H
- 8 PROFIBUS DP and PA networking segments
- Single plant bus, one switch
- Single terminal bus, one switch
- 240 process devices with asset monitoring functionality

This configuration requires:

Table 13–6

Element	Count value	Asset Management tags	Process objects	PDM tags
Computer	5	5	0	0
PROFIBUS PA	300	300	0	300
HART	180	180	0	180
FOUNDATION Fieldbus H1	80	80	0	80
ET200M IM bus interface	20	20	0	0
ET200M module	135	0	0	0
PROFIBUS DP slaves - EDDL	160	160	0	160
PROFIBUS DP slaves - without EDDL	60	60	0	0
Automation system	2	2	0	0
System bus switches	1	1	0	0
Terminal bus switches	1	1	0	0
Networks	10	0	0	0
Process devices	240	240	240	240
Totals				
		1049	240	960

Bill of material for the asset management client/server, based on the sample invoice

Table 13–7

Required	Optional	Product number	Product description	Note
Engineering System				
1		6ES7660-2AA30-1CA0	SIMATIC PCS 7 INDUSTRIAL WORKSTATION IPC847C, CORE I7, ES/OS SINGLESTATION, RAID1 (500GB INTERNAL), 8GB DDR3, BCE, PCS 7 V8.0 SP1, WIN 7	
1		6ES7 658-5AX08-0YA5	SOFTWARE SIMATIC PCS 7 AS/OS ENGINEERING V8.0	
	1	6ES7 652-0XD08-2YB5	SOFTWARE SIMATIC PCS 7 SFC VISUALIZATION V8.0	
	1	6ES7 658-1CX17-2YA5	SOFTWARE SIMATIC PCS 7 VERSION CROSS MANAGER V7.1	
	1	6ES7 658-1FX08-2YA5	SOFTWARE SIMATIC PCS 7 VERSION TRAIL V8.0	
	1	6ES7 658-1DX08-2YB5	SOFTWARE SIMATIC PCS 7 IMPORT EXPORT ASSISTANT V8.0	
1		6ES7 658-3LD08-0YA5	SOFTWARE SIMATIC PDM PCS 7 V8.1 (100 TAG)	4)
1		6ES7658-3XE00-2YB5	SIMATIC PDM 1000 TAGs	5)
1		6ES7658-3QX18-2YB5	SOFTWARE SIMATIC PDM Communication FOUNDATION Fieldbus V8	6)
1		6ES7 658-7GX08-0YB5	SIMATIC PCS 7 Maintenance Station Engineering V8.0	
1		6ES7 658-2CX08-0YB5	SOFTWARE SIMATIC PCS 7 OS CLIENT V8.0	
Operator System server maintenance server				
1		6ES7660-2BA30-1DA0	SIMATIC PCS 7 INDUSTRIAL WORKSTATION IPC847C, CORE I7, OS SERVER, RAID1 (500GB INTERNAL), 8GB DDR3, BCE, PCS 7 V8.0 SP1, WIN SERVER 2008	
1		6ES7 658-2BA08-0YA0	SOFTWARE SIMATIC PCS 7 OS SOFTWARE SERVER V8.0 (PO 100)	1)
1		6ES7 658-7GX08-0YB5	SOFTWARE SIMATIC PCS 7 Maintenance Station Runtime Basic Package V8.0 (incl. SNMP-OPC server license and 100 Asset TAGs)	5)
1		6ES7 658-7GC00-2YB0	1000 ASSET-TAGs	5)
Operator System client				
3		6ES7660-1CA18-1CA0	SIMATIC PCS 7 INDUSTRIAL WORKSTATION IPC647C, CORE I7, OS CLIENT, 500GB INTERNAL, 4GB DDR3, PCS 7 V8.0 SP1, WIN 7	
3		6ES7 658-2CX08-0YB5	SOFTWARE SIMATIC PCS 7 OS CLIENT V8.0	
	3	6ES7 652-0XD08-2YB5	SOFTWARE SIMATIC PCS 7 SFC VISUALIZATION V8.0	

Required	Optional	Product number	Product description	Note
Terminal bus				
1		6GK5 208-0BA10-2AA3	SIMATIC NET SCALANCE X208, MANAGED IE SWITCH, 8 X 10/100MBIT/S	²⁾
5		6XV1 870-3QH60	SIMATIC NET INDUSTRIAL ETHERNET TP CORD CABLE RJ45/RJ45, 6M	
System bus				
1		6GK5 208-0BA10-2AA3	SIMATIC NET SCALANCE X208, MANAGED IE SWITCH, 8 X 10/100MBIT/S	²⁾
4		6XV1 870-3QH60	SIMATIC NET INDUSTRIAL ETHERNET TP CORD CABLE RJ45/RJ45, 6M	
Automation system				
2		6ES7 654-6CP03-3BF0	SIMATIC PCS 7 SINGLE AS, CPU 410-5H, 1X DP-MODULE, 1x PROFINET-IO, SYSTEM EXPANSIONS CARD 1600 PO, AS RT PO 100, CP443-1IE, UR2 ALU RACK, 1 X UC 120/230V 10A POWER SUPPLY	³⁾

Note

- ¹⁾ The number of POs can be increased later on by means of extra volume licenses.
- ²⁾ SCALANCE switch requires a 24VDC power supply (not listed).
- ³⁾ Please use the PCS 7 AS configurator, as the PCS 7 AS 410-5H is available in different versions, e.g. 24V DC or 110/230V AC.
- ⁴⁾ The number of TAGs can be increased by means of cumulative TAG licenses in steps of 10/100/1000.
- ⁵⁾ The number of Asset TAGs can be increased by means of cumulative Asset TAG licenses.
- ⁶⁾ Optional for FOUNDATION Fieldbus communication

13.4 Asset Management Client/server with a single maintenance server

Figure 13-4

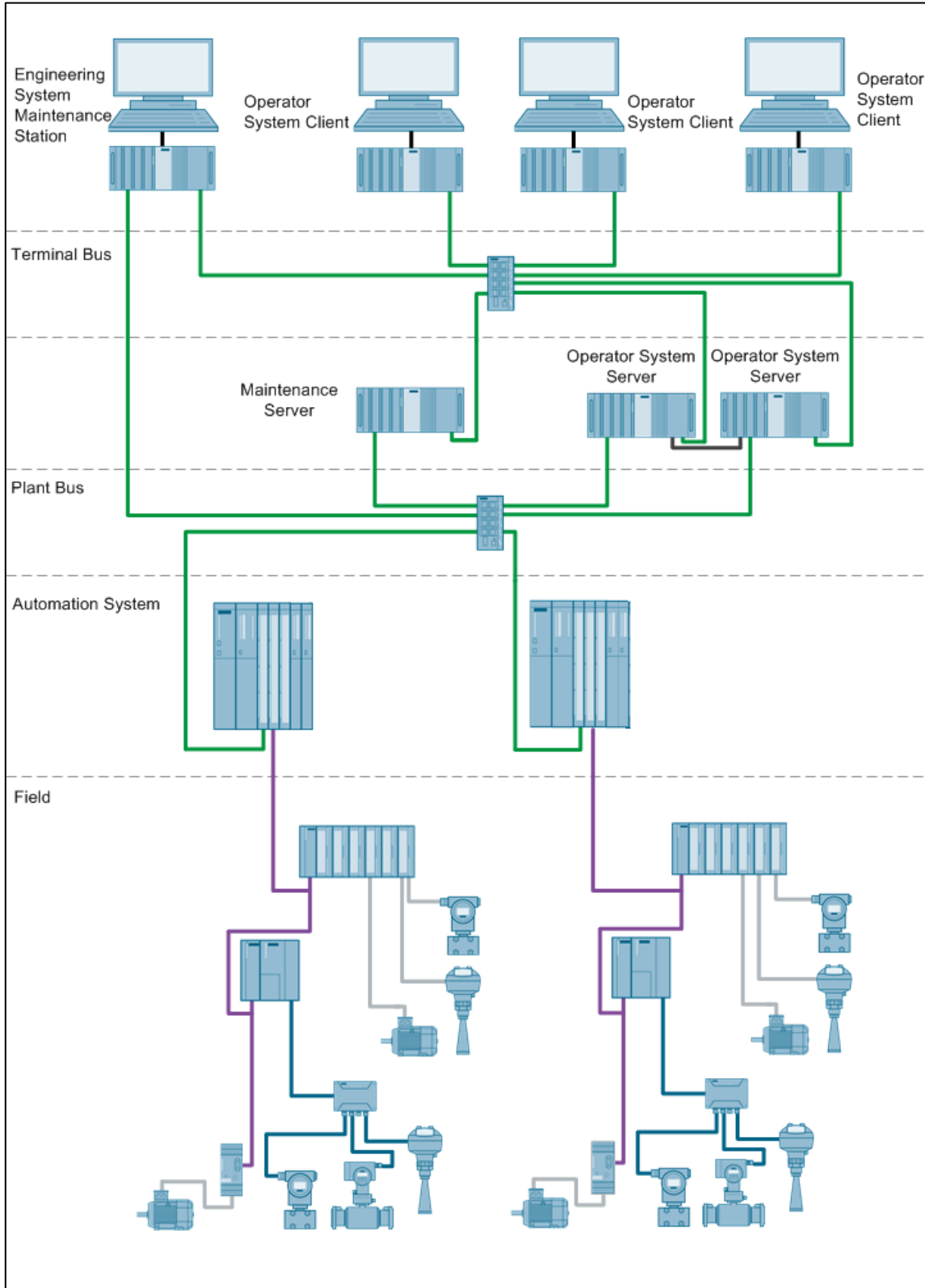

Copyright © Siemens AG 2013 All rights reserved

Bill of material for the Asset Management client/server system with a single maintenance server

Table 13–8

Required	Optional	Product number	Product description	Note
Engineering System				
1		6ES7660-2AA30-1CA0	SIMATIC PCS 7 INDUSTRIAL WORKSTATION IPC847C, CORE I7, ES/OS SINGLESTATION, RAID1 (500GB INTERNAL), 8GB DDR3, BCE, PCS 7 V8.0 SP1, WIN 7	
1		6ES7 658-5AX08-0YA5	SOFTWARE SIMATIC PCS 7 AS/OS ENGINEERING V8.0	
	1	6ES7 652-0XD08-2YB5	SOFTWARE SIMATIC PCS 7 SFC VISUALIZATION V8.0	
	1	6ES7 658-1CX17-2YA5	SOFTWARE SIMATIC PCS 7 VERSION CROSS MANAGER V7.1	
	1	6ES7 658-1FX08-2YA5	SOFTWARE SIMATIC PCS 7 VERSION TRAIL V8.0	
	1	6ES7 658-1DX08-2YB5	SOFTWARE SIMATIC PCS 7 IMPORT EXPORT ASSISTANT V8.0	
1		6ES7 658-3LD08-0YA5	SOFTWARE SIMATIC PDM PCS 7 V8.1	4)
	1	6ES7 658-3QX18-2YB5	SOFTWARE SIMATIC PDM Communication FOUNDATION Fieldbus V8.1	7)
1		6ES7 658-7GX08-0YB5	SIMATIC PCS 7 Maintenance Station Engineering V8.0ASSET	
1		6ES7 658-2CX08-0YB5	SOFTWARE SIMATIC PCS 7 OS CLIENT V8.0	
Operator System server				
2		6ES7660-2BB31-1DA0	SIMATIC PCS 7 INDUSTRIAL WORKSTATION IPC847C, CORE I7, OS SERVER, RAID1 (500GB FRONT MOUNTED), 8GB DDR3, INDUSTRIAL ETHERNET (CP1623), PCS 7 V8.0 SP1, WIN SERVER 2008	
1		6ES7 652-3BA08-2YA0	SOFTWARE SIMATIC PCS 7 OS SERVER REDUNDANCY V8.0 (PO 100)	1) 6)
Maintenance server				
1		6ES7660-2BA30-1DA0	SIMATIC PCS 7 INDUSTRIAL WORKSTATION IPC847C, CORE I7, OS SERVER, RAID1 (500GB INTERNAL), 8GB DDR3, BCE, PCS 7 V8.0 SP1, WIN SERVER 2008	
1		6ES7 658-2BA08-0YA0	SOFTWARE SIMATIC PCS 7 OS SOFTWARE SERVER V8.0 (PO 100)	1) 6)
1		6ES7 658-7GB08-0YB0	SOFTWARE SIMATIC PCS 7 Maintenance Station Runtime Basic Package V8.0 (incl. SNMP-OPC server license and 100 Asset TAGs)	5)

Required	Optional	Product number	Product description	Note
Operator System client				
3		6ES7660-1CA18-1CA0	SIMATIC PCS 7 INDUSTRIAL WORKSTATION IPC647C, CORE I7, OS CLIENT, 500GB INTERNAL, 4GB DDR3, PCS 7 V8.0 SP1, WIN 7	
3		6ES7 658-2CX08-0YB5	SOFTWARE SIMATIC PCS 7 OS CLIENT V8.0	
	3	6ES7 652-0XD08-2YB5	SOFTWARE SIMATIC PCS 7 SFC VISUALIZATION V8.0	
Terminal bus				
1		6GK5 208-0BA10-2AA3	SIMATIC NET SCALANCE X208, MANAGED IE SWITCH, 8 X 10/100MBIT/S	²⁾
7		6XV1 870-3QH60	SIMATIC NET INDUSTRIAL ETHERNET TP CORD CABLE RJ45/RJ45, 6M	
System bus				
1		6GK5 208-0BA10-2AA3	SIMATIC NET SCALANCE X208, MANAGED IE SWITCH, 8 X 10/100MBIT/S	²⁾
6		6XV1 870-3QH60	SIMATIC NET INDUSTRIAL ETHERNET TP CORD CABLE RJ45/RJ45, 6M	
Automation system				
2		6ES7 654-6CN03-3BF0	SIMATIC PCS 7 SINGLE AS, CPU 410-5H, 1X DP-MODULE, 1x PROFINET-IO, SYSTEM EXPANSIONS CARD 1000 PO, AS RT PO 100, CP443-1IE, UR2 ALU RACK, 1 X UC 120/230V 10A POWER SUPPLY	³⁾

Note

- ¹⁾ The number of POs can be increased later on by means of extra volume licenses.
- ²⁾ SCALANCE switch requires a 24VDC power supply (not listed).
- ³⁾ Please use the PCS 7 AS configurator, as the PCS 7 AS 410-5H is available in different versions, e.g. 24V DC or 110/230V AC.
- ⁴⁾ The number of TAGs can be increased by means of cumulative TAG licenses.
- ⁵⁾ Note for asset runtime:
 - The number of asset TAGs can be increased by means of cumulative asset TAG licenses. An increase of the asset TAGs requires an increase of AS and OS RT process objects for the maintenance server.
- ⁶⁾ The redundant OS server is supplied with an RS-232 serial connection cable. If there is a long distance between the redundant systems, one can establish an Ethernet connection as an alternative. This requires additional Ethernet network interface cards in the systems.
- ⁷⁾ Optional for FOUNDATION Fieldbus communication

13.5 Redundant Asset Management Client/server

Figure 13-5

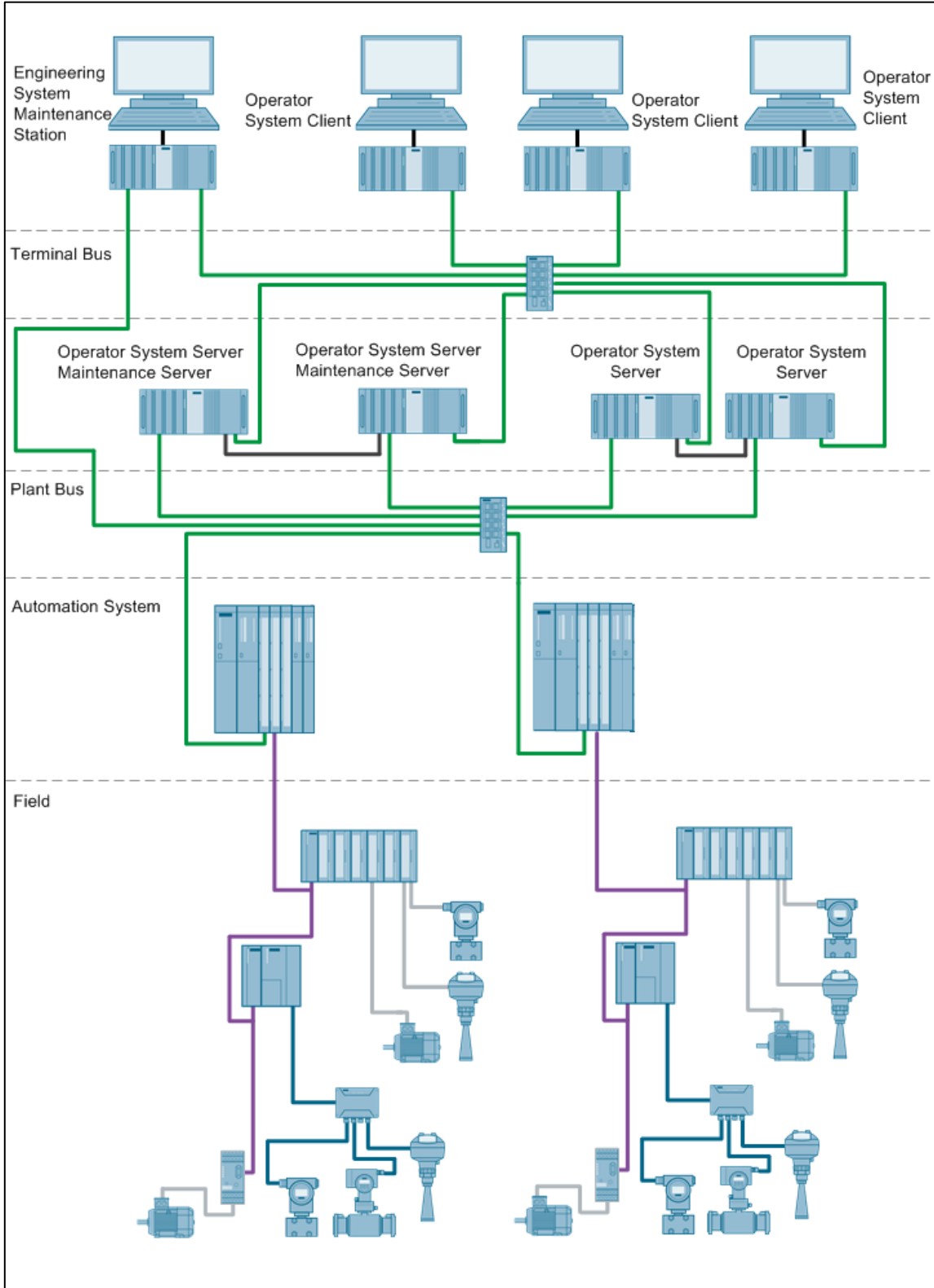

Bill of material for the redundant Asset Management Client/server system

Table 13–9

Required	Optional	Product number	Product description	Note
Engineering System				
1		6ES7660-2AA30-1CA0	SIMATIC PCS 7 INDUSTRIAL WORKSTATION IPC847C, CORE I7, ES/OS SINGLESTATION, RAID1 (500GB INTERNAL), 8GB DDR3, BCE, PCS 7 V8.0 SP1, WIN 7	
1		6ES7 658-5AX08-0YA5	SOFTWARE SIMATIC PCS 7 AS/OS ENGINEERING V8.0	
	1	6ES7 652-0XD08-2YB5	SOFTWARE SIMATIC PCS 7 SFC VISUALIZATION V8.0	
	1	6ES7 658-1CX17-2YA5	SOFTWARE SIMATIC PCS 7 VERSION CROSS MANAGER V7.1	
	1	6ES7 658-1FX08-2YA5	SOFTWARE SIMATIC PCS 7 VERSION TRAIL V8.0	
	1	6ES7 658-1DX08-2YB5	SOFTWARE SIMATIC PCS 7 IMPORT EXPORT ASSISTANT V8.0	
1		6ES7 658-3LD08-0YA5	SOFTWARE SIMATIC PDM PCS 7 V8.1	4)
	1	6ES7 658-3QX18-2YB5	SOFTWARE SIMATIC PDM Communication FOUNDATION Fieldbus V8.1	7)
1		6ES7 658-7GX08-0YB5	SIMATIC PCS 7 Maintenance Station Engineering V8.0	
1		6ES7 658-2CX08-0YB5	SOFTWARE SIMATIC PCS 7 OS CLIENT V8.0	
Operator System server				
2		6ES7660-2BB31-1DA0	SIMATIC PCS 7 INDUSTRIAL WORKSTATION IPC847C, CORE I7, OS SERVER, RAID1 (500GB FRONT MOUNTED), 8GB DDR3, INDUSTRIAL ETHERNET (CP1623), PCS 7 V8.0 SP1, WIN SERVER 2008	
1		6ES7 652-3BA08-2YA0	SOFTWARE SIMATIC PCS 7 OS SERVER REDUNDANCY V8.0 (PO 100)	1) 6)
Operator System server maintenance server				
2		6ES7660-2BB31-1DA0	SIMATIC PCS 7 INDUSTRIAL WORKSTATION IPC847C, CORE I7, OS SERVER, RAID1 (500GB FRONT MOUNTED), 8GB DDR3, INDUSTRIAL ETHERNET (CP1623), PCS 7 V8.0 SP1, WIN SERVER 2008	
1		6ES7 652-3BA08-2YA0	SOFTWARE SIMATIC PCS 7 OS SERVER REDUNDANCY V8.0 (PO 100)	1) 6)
2		6ES7 658-7GB08-0YB0	SOFTWARE SIMATIC PCS 7 Maintenance Station Runtime Basic Package V8.0 (incl. SNMP-OPC server license and 100 Asset TAGs)	5)
Operator System client				
3		6ES7660-1CA18-1CA0	SIMATIC PCS 7 INDUSTRIAL WORKSTATION IPC647C, CORE I7, OS CLIENT, 500GB INTERNAL, 4GB DDR3, PCS 7 V8.0 SP1, WIN 7	
3		6ES7 658-2CX08-0YB5	SOFTWARE SIMATIC PCS 7 OS CLIENT V8.0	

Required	Optional	Product number	Product description	Note
	3	6ES7 652-0XD08-2YB5	SOFTWARE SIMATIC PCS 7 SFC VISUALIZATION V8.0	
Terminal bus				
1		6GK5 208-0BA10-2AA3	SIMATIC NET SCALANCE X208, MANAGED IE SWITCH, 8 X 10/100MBIT/S	²⁾
8		6XV1 870-3QH60	SIMATIC NET INDUSTRIAL ETHERNET TP CORD CABLE RJ45/RJ45, 6M	
System bus				
1		6GK5 208-0BA10-2AA3	SIMATIC NET SCALANCE X208, MANAGED IE SWITCH, 8 X 10/100MBIT/S	²⁾
7		6XV1 870-3QH60	SIMATIC NET INDUSTRIAL ETHERNET TP CORD CABLE RJ45/RJ45, 6M	
Automation system				
2		6ES7 654-6CN03-3BF0	SIMATIC PCS 7 SINGLE AS, CPU 410-5H, 1X DP-MODULE, 1x PROFINET-IO, SYSTEM EXPANSIONS CARD 1000 PO, AS RT PO 100, CP443-1IE, UR2 ALU RACK, 1 X UC 120/230V 10A POWER SUPPLY	³⁾

Note

- ¹⁾ The number of POs can be increased later on by means of extra volume licenses.
- ²⁾ SCALANCE switch requires a 24VDC power supply (not listed).
- ³⁾ Please use the PCS 7 AS configurator, as the PCS 7 AS 410-5H is available in different versions, e.g. 24V DC or 110/230V AC.
- ⁴⁾ The number of TAGs can be increased by means of cumulative TAG licenses.
- ⁵⁾ Note for asset runtime:
 - The number of Asset TAGs can be increased by means of cumulative Asset TAG licenses.
 - An increase of the asset TAGs requires an increase of AS and OS RT process objects for the maintenance server.
- ⁶⁾ The redundant OS server is supplied with an RS-232 serial connection cable. If there is a long distance between the redundant systems, one can establish an Ethernet connection as an alternative. This requires additional Ethernet network interface cards in the systems.

Sample invoice for the redundant Asset Management Client/server system

The following is a sample invoice for the number of asset management tags, process objects and PDM tags for a given redundant client/server configuration.

The redundant client/server configuration includes:

- one ES/OS/MS client PC
- one pair of OS/MS servers
- one pair of OS servers
- three OS clients
- 300 PROFIBUS PA sensors and actuators
- 180 HART analog sensors and actuators
- 80 FOUNDATION Fieldbus H1 sensors and actuators
- 20 ET200M IO racks, total of 135 IO modules
- 160 PROFIBUS DP slaves with EDDL configuration
- 60 PROFIBUS DP slaves without EDDL configuration
- 2 AS 410-5H
- 8 PROFIBUS DP and PA networking segments
- Single plant bus, one switch
- Single terminal bus, one switch
- 240 process devices with asset monitoring functionality

Table 13–10

Element	Count value	Asset Management tags	Process objects	PDM tags
Computer	8	8	0	0
PROFIBUS PA	300	300	0	300
HART	180	180	0	180
FOUNDATION Fieldbus H1	80	80	0	80
ET200M IM bus interface	20	20	0	0
ET200M module	135	0	0	0
PROFIBUS DP slaves - EDDL	160	160	0	160
PROFIBUS DP slaves - without EDDL	60	60	0	0
Automation system	2	2	0	0
System bus switches	1	1	0	0
Terminal bus switches	1	1	0	0
Networks	10	0	0	0
Process devices	240	240	240	240
Totals				
		1052	240	960

Bill of material for the asset management client/server, redundant, based on the sample invoice

Table 13–11

Required	Optional	Product number	Product description	Note
Engineering System				
1		6ES7660-2AA30-1CA0	SIMATIC PCS 7 INDUSTRIAL WORKSTATION IPC847C, CORE I7, ES/OS SINGLESTATION, RAID1 (500GB INTERNAL), 8GB DDR3, BCE, PCS 7 V8.0 SP1, WIN 7	
1		6ES7 658-5AX08-0YA5	SOFTWARE SIMATIC PCS 7 AS/OS ENGINEERING V8.0	
	1	6ES7 652-0XD08-2YB5	SOFTWARE SIMATIC PCS 7 SFC VISUALIZATION V8.0	
	1	6ES7 658-1CX17-2YA5	SOFTWARE SIMATIC PCS 7 VERSION CROSS MANAGER V7.1	
	1	6ES7 658-1FX08-2YA5	SOFTWARE SIMATIC PCS 7 VERSION TRAIL V8.0	
	1	6ES7 658-1DX08-2YB5	SOFTWARE SIMATIC PCS 7 IMPORT EXPORT ASSISTANT V8.0	
1	-	6ES7 658-3LD08-0YA5	SOFTWARE SIMATIC PDM PCS 7 V8.1 (100 TAG)	
1		6ES7658-3XE00-2YB5	SIMATIC PDM 1000 TAGs	
1		6ES7658-3QX18-2YB5	SOFTWARE SIMATIC PDM Communication FOUNDATION Fieldbus V8	
1		6ES7 658-7GX17-0YB5	ASSET ENGINEERING	
1		6ES7 658-2CX08-0YB5	SOFTWARE SIMATIC PCS 7 OS CLIENT V8.0	
Operator System server				
2		6ES7660-2BB31-1DA0	SIMATIC PCS 7 INDUSTRIAL WORKSTATION IPC847C, CORE I7, OS SERVER, RAID1 (500GB FRONT MOUNTED), 8GB DDR3, INDUSTRIAL ETHERNET (CP1623), PCS 7 V8.0 SP1, WIN SERVER 2008	
1		6ES7 652-3BA08-2YA0	SOFTWARE SIMATIC PCS 7 OS SERVER REDUNDANCY V8.0 (PO 100)	³⁾
Operator System server maintenance server				
2		6ES7660-2BB31-1DA0	SIMATIC PCS 7 INDUSTRIAL WORKSTATION IPC847C, CORE I7, OS SERVER, RAID1 (500GB FRONT MOUNTED), 8GB DDR3, INDUSTRIAL ETHERNET (CP1623), PCS 7 V8.0 SP1, WIN SERVER 2008	
1		6ES7 652-3BA08-2YA0	SOFTWARE SIMATIC PCS 7 OS SERVER REDUNDANCY V8.0 (PO 100)	³⁾
2		6ES7 658-7GX08-0YB5	SOFTWARE SIMATIC PCS 7 Maintenance Station Runtime Basic Package V8.0 (incl. SNMP-OPC server license and 100 Asset TAGs)	
2		6ES7 658-7GC00-2YB0	1000 ASSET-TAGs	

Required	Optional	Product number	Product description	Note
Operator System client				
3		6ES7660-1CA18-1CA0	SIMATIC PCS 7 INDUSTRIAL WORKSTATION IPC647C, CORE I7, OS CLIENT, 500GB INTERNAL, 4GB DDR3, PCS 7 V8.0 SP1, WIN 7	
3		6ES7 658-2CX08-0YB5	SOFTWARE SIMATIC PCS 7 OS CLIENT V8.0	
	3	6ES7 652-0XD08-2YB5	SOFTWARE SIMATIC PCS 7 SFC VISUALIZATION V8.0	
Terminal bus				
1		6GK5 208-0BA10-2AA3	SIMATIC NET SCALANCE X208, MANAGED IE SWITCH, 8 X 10/100MBIT/S	1)
10		6XV1 870-3QH60	SIMATIC NET INDUSTRIAL ETHERNET TP CORD CABLE RJ45/RJ45, 6M	
System bus				
1		6GK5 208-0BA10-2AA3	SIMATIC NET SCALANCE X208, MANAGED IE SWITCH, 8 X 10/100MBIT/S	1)
7		6XV1 870-3QH60	SIMATIC NET INDUSTRIAL ETHERNET TP CORD CABLE RJ45/RJ45, 6M	
Automation system				
2		6ES7 654-6CP03-3BF0	SIMATIC PCS 7 SINGLE AS, CPU 410-5H, 1X DP-MODULE, 1x PROFINET-IO, SYSTEM EXPANSIONS CARD 500 PO, AS RT PO 100, CP443-1IE, UR2 ALU RACK, 1 X UC 120/230V 10A POWER SUPPLY	2)

Note

- 1) SCALANCE switch requires a 24VDC power supply (not listed).
- 2) Please use the PCS 7 AS configurator, as the PCS 7 AS 410-5H is available in different versions, e.g. 24V DC or 110/230V AC.
- 3) The redundant OS server is supplied with an RS-232 serial connection cable. If there is a long distance between the redundant systems, one can establish an Ethernet connection as an alternative. This requires additional Ethernet network interface cards in the systems.

14 Fieldbus

Single DP-PA-FF PROFINET fieldbus

SIMATIC PCS 7 enables the connection of different fieldbus technologies through its flexible architecture and seamless integration. To connect the process devices to the process automation system, it is possible to use either PROFINET or the proven PROFIBUS DP.

PROFINET is based on the international standards IEC 61158 and IEC 61784 and combines the advantages of the open network standard, Ethernet, and the PROFIBUS fieldbus system.

PROFINET supports communication of a large number of devices at field level with a speed of up to 100 MBit/s. The devices supported include PROFINET Remote IOs as well as PROFIBUS DP compact devices and PROFIBUS PA, via their integrated IE/PB Link PN IO.

Note

In the application example "SIMATIC PCS 7 with PROFINET - typical configurations and engineering" with the item ID: 72887082, you can find further information about PROFINET integration in PCS 7 with typical PCS 7 architectures and configuration examples.

The PROFIBUS DP is based on the robust RS-485 technology and is a versatile, proven fieldbus that supports a reliable high-speed data exchange with a large number of slaves. SIMATIC PCS 7 automation systems are equipped with the PROFIBUS DP master functionality and can be extended to several PROFIBUS DP networks.

Repeaters increase the expansion of the PROFIBUS network over multiple isolated segments and thus also the number of possible devices. If diagnostics functions for physical cable diagnostics are desired in addition to the standard repeater functionality, a diagnostics repeater can be alternatively used. It monitors the copper bus cables in online mode. In the event of a fault it sends a diagnostic message with detailed information about the type and location of the fault to the PROFIBUS DP master.

Intelligent field devices based on the PROFIBUS PA and FOUNDATION Fieldbus H1 standards can be integrated in the SIMATIC PCS 7 by connecting them directly to the high-speed PROFIBUS DP via the dedicated gateways (e.g. PA Link and FF Link). In addition to data transmission, the PROFIBUS PA and FOUNDATION Fieldbus H1 field devices are powered via bus.

Note

In the application example "Configuration of FOUNDATION Fieldbus H1 (SS) with SIMATIC PCS 7" with the item ID: 64329637, you can find further information about PROFINET integration in PCS 7 with typical PCS 7 architectures and configuration examples.

DP/PA coupler, PA Link and FF Link components act as gateways between the high-speed PROFIBUS DP networks and the bus-powered PA/FF page. This makes it possible to use a larger number of PROFIBUS PA slaves and FF field devices without overloading the existing PROFIBUS DP address space.

Energy limiting components for PROFIBUS DP, PROFIBUS PA and FOUNDATION Fieldbus H1 enable field devices to be used directly in a hazardous environment.

Single optical PROFIBUS DP

In order to realize greater distances, to reach ring fault tolerance and galvanic isolation, PROFIBUS DP enables the use of fiber-optic network components. The logical bus topology remains a single line, while the fault-tolerant ring increases availability.

Redundant optical PROFIBUS DP

The optical PROFIBUS DP can also be constructed as a ring. By combining the redundant PROFIBUS DP and fiber network components as a ring, you get the highest availability and galvanic isolation. The combination of a double fault-tolerant ring allows multiple faults to occur without losing the field connection.

Redundant electrical PROFIBUS DP, PROFIBUS PA and FOUNDATION FIELDBUS H1

If high availability is required, PROFIBUS DP supports the extension of redundant networks to IO racks as well as DP/PA and FF links. A redundant PROFIBUS DP network consists of two separate electric lines connected to two independent PROFIBUS masters and multiple redundant DP Slaves. The PA Link and FF Link gateways provide the opportunity to build the field device bus PROFIBUS PA or FOUNDATION Fieldbus H1 as a fault-tolerant ring, thereby increasing the availability of the complete field device network. The redundant PROFIBUS PA and redundant FOUNDATION Fieldbus H1 are available in combination with single and redundant PROFIBUS DP networks.

Redundancy concept for PROFINET fieldbus

PROFINET provides the field level with the availability of two redundancy concepts.

This includes the increase of availability of IO devices through a ring topology with media redundancy (MRP). If the transmission link in the ring is interrupted at a given location, for example, due to a break in the ring cable or the failure of a station, the redundancy manager, e.g. the IO controller, immediately activates the alternative communication path.

With a typical reconfiguration time of 200 ms and up to 50 PROFINET IO devices in a ring, MRP behaves deterministically and is defined in the IEC 62439 standard.

Figure 14-1 PROFINET with MRP

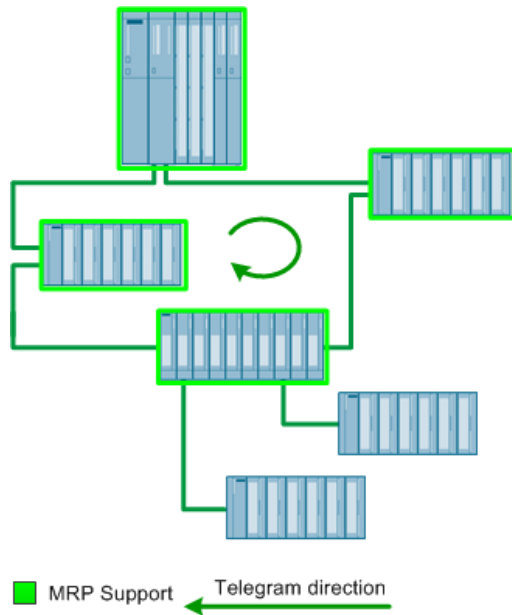

The second way to increase availability is by using system redundancy. In this case, communication connections are established between an IO device and both IO Controllers (active and backup CPU) in a high-availability automation system (redundant IO controller). The active IO controller marks its output data as primary. IO devices ignore output data which is not marked. Thus, in case of failure, the backup CPU of the redundant automation system can take control over all IO devices, without interruptions, by marking its output data as primary.

Figure 14-2 PROFINET with system redundancy

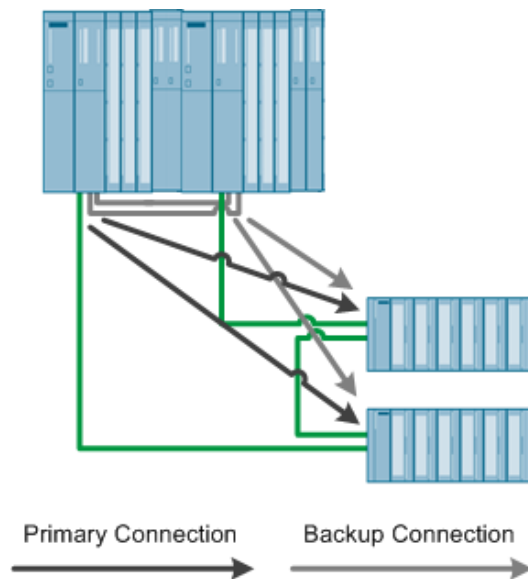

14.1 Single DP-PA / DP-FF fieldbus

Figure 14-3

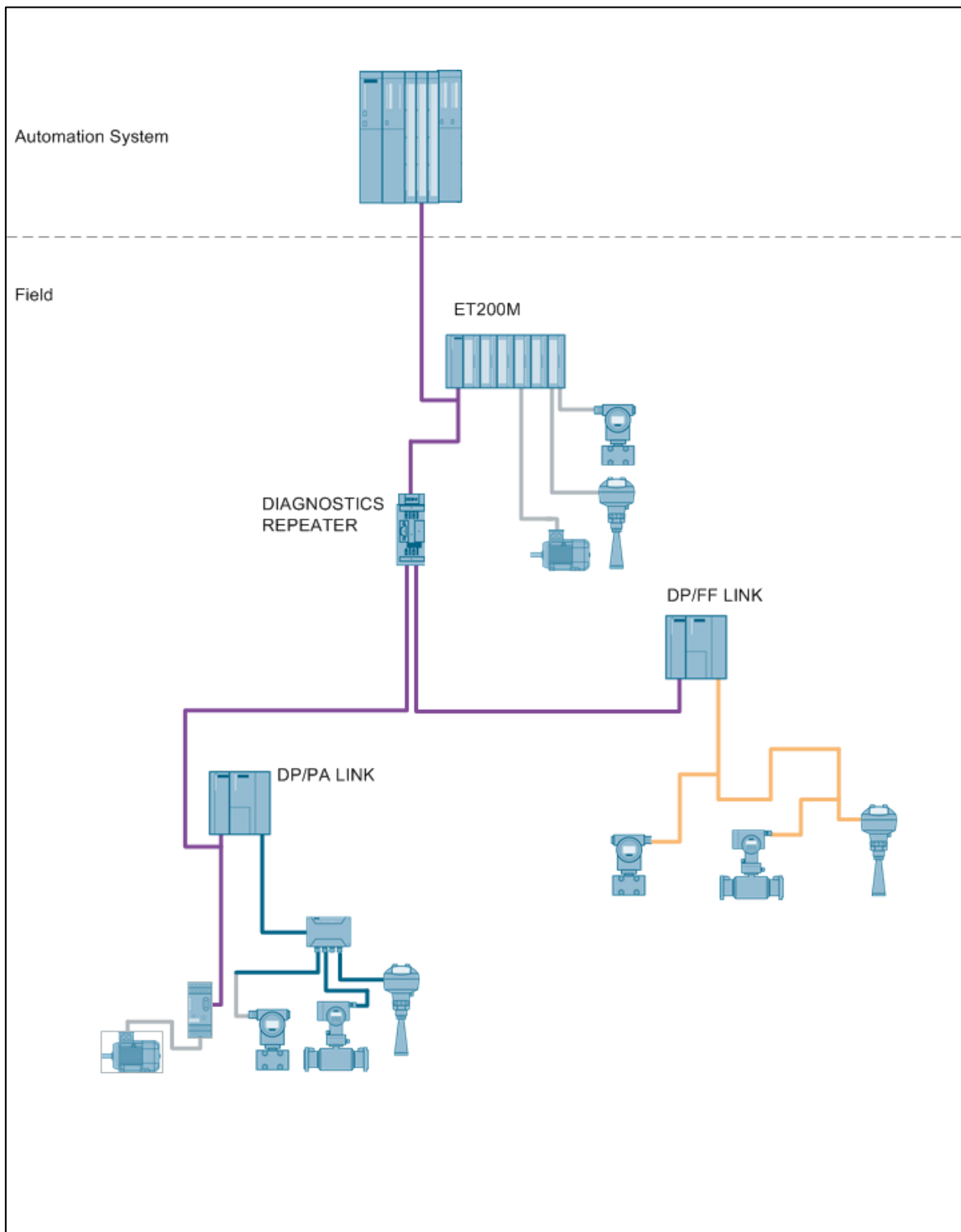

Copyright © Siemens AG 2013 All rights reserved

Bill of material for the single DP-PA / DP-FF fieldbus

Table 14–1

Required	Optional	Product number	Product description	Note
Automation system				
1		6ES7 654-6CL03-3BF0	SIMATIC PCS 7 SINGLE AS, CPU 410-5H, 1X DP-MODULE, 1x PROFINET-IO, SYSTEM EXPANSIONS CARD 500 PO, AS RT PO 100, CP443-1IE, UR2 ALU RACK, 1 X UC 120/230V 10A POWER SUPPLY	1)
ET200M				
1		6ES7 654-0XX08-1XA0	SIMATIC PCS 7 I/O SUBSYSTEM HOT SWAPPING, 8 I/O FOR ET200M	2)
DIAGNOSTICS REPEATER				
	1	6ES7 972-0AA02-0XA0	SIMATIC DP, RS485 DIAGNOSTICS REPEATER	2)
DP/PA LINK				
1		6ES7 153-2BA82-0XB0	SIMATIC DP, INTERFACE DP/PA-LINK A. ET200M IM153-2 HF	3)
1		6ES7 157-0AC83-0XA0	SIMATIC DP, FIELD DEVICE LINK DP/PA COUPLER FDC 157-0 NON EX-VERSION	4)
1		6ES7 195-1GA00-0XA0	SIMATIC DP, RAIL FOR ET 200M 483 MM	5)
1		6ES7 195-7HA00-0XA0	SIMATIC DP, BUS UNIT FOR ET200M F. THE INTEGR.OF 1 PS A.1 IM153	
1		6ES7 195-7HF80-0XA0	SIMATIC DP, BUS UNIT BM DP/PA FOR EXPANDED TEMPERATURE RANGE	
FF LINK				
1		6ES7658-3MD18-0YA 5	SIMATIC PDM PCS 7-FF V8.1 (100 TAG)	7)
1		6ES7 153-2DA80-0XB0	SIMATIC FF LINK, IM 153-2 FF	6)
1		6ES7 157-0AC83-0XA0	SIMATIC DP, FIELD DEVICE LINK DP/PA COUPLER FDC 157-0	
1		6ES7 195-1GA00-0XA0	SIMATIC DP, RAIL FOR ET 200M 483 MM	
1		6ES7 195-7HA00-0XA0	SIMATIC DP, BUS UNIT FOR ET200M F. THE INTEGR.OF 1 PS A.1 IM153	
1		6ES7 195-7HF80-0XA0	SIMATIC DP, BUS UNIT BM DP/PA FOR EXPANDED TEMPERATURE RANGE	

Note

¹⁾ Please use the PCS 7 AS configurator, as the PCS 7 AS 410-5H is available in different versions, e.g. 24V DC or 110/230V AC.

Notes regarding PROFIBUS DP:

- The maximum number of PROFIBUS DP slaves per master is 125 (typically 30 - 80)
- The maximum number of slaves per segment is 32, segments are separated from repeaters (diagnostics)

²⁾ ET200M, IM 153-2, diagnostics repeaters require a 24VDC power supply (not listed).

³⁾ Max. 64 field devices per DP/PA Link, IM 153-2 requires a 24VDC power supply (not listed).

⁴⁾ Notes regarding FDC 157-0:

- Max. 5 FDC 157-0 DP/PA couplers in a DP/PA link
- Max. 31 field devices per FDC 157-0. (typically 20 - 25)
- The maximum current supplied from FDC 157-0 is 1,000 mA
- The maximum PA segment length is 1,900 m (typically 500 - 1,000 m)

⁵⁾ Larger lengths are available.

⁶⁾ Max. 64 field devices per FF link (typically 8 - 12).

- Max. 1 FDC 157-0 DP/FF coupler (or 2 in a ring) in one FF link
- Max. 31 field devices per FDC 157. (typically 8 - 12)
- The maximum current supplied from FDC 157 is 1,000 mA
- The maximum FF segment length is 1,900 m (typically 500 - 1,000 m)

⁷⁾ Only one additional license is needed for FF communication if a PDM V8.1 license that includes routing exists. You can find this optional license in the PCS 7 catalog.

14.2 Single optical DP-PA / DP-FF fieldbus

Figure 14-4

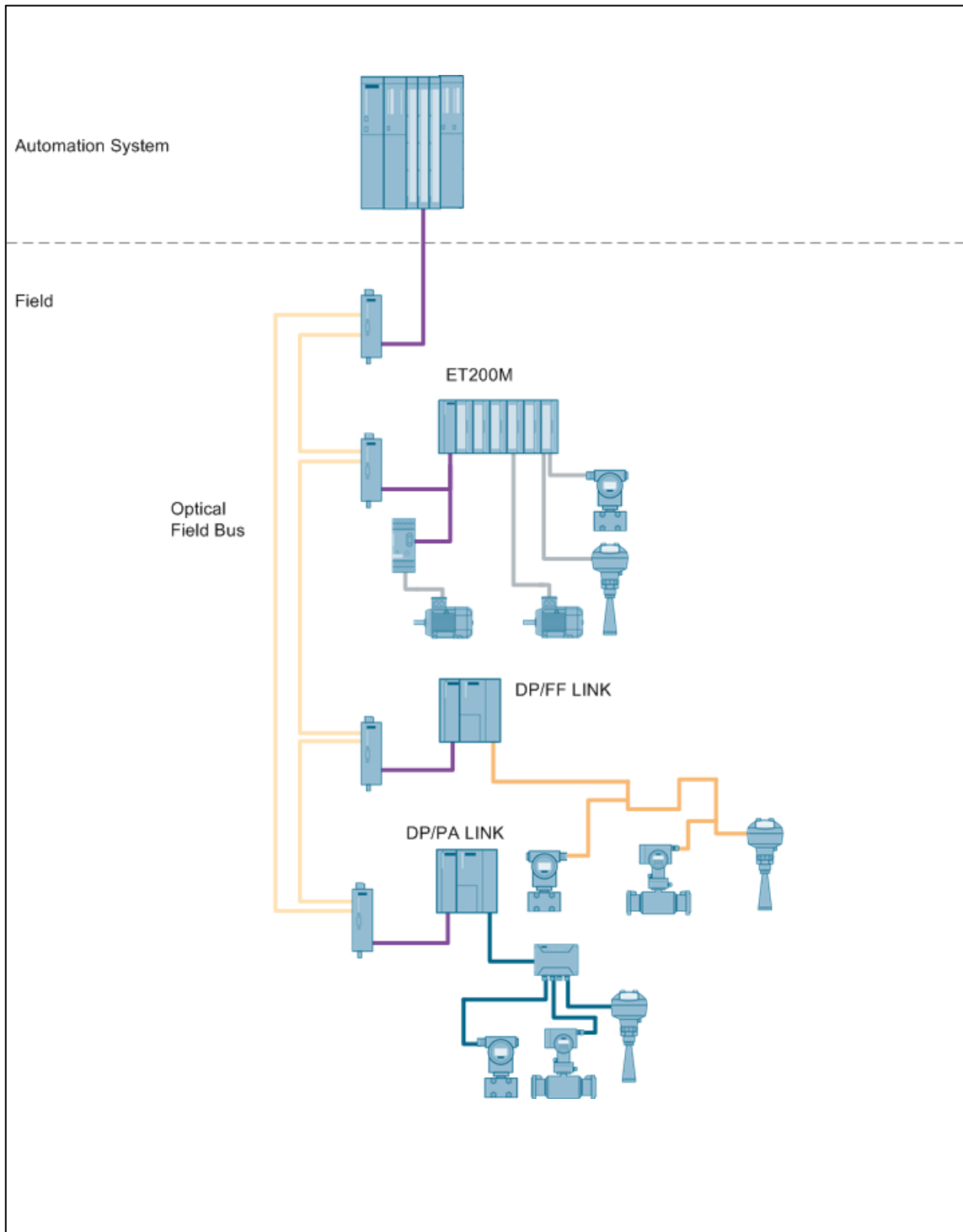

Copyright © Siemens AG 2013 All rights reserved

Bill of material for the single DP-PA / DP-FF fieldbus

Table 14–2

Required	Optional	Product number	Product description	Note
Automation system				
1		6ES7 654-6CL03-3BF0	SIMATIC PCS 7 SINGLE AS, CPU 410-5H, 1X DP-MODULE, 1x PROFINET-IO, SYSTEM EXPANSIONS CARD 500 PO, AS RT PO 100, CP443-1IE, UR2 ALU RACK, 1 X UC 120/230V 10A POWER SUPPLY	1)
OPTICAL FIELDBUS				
4		6GK1 503-3CB00	PROFIBUS OLM/G12 V4.0 OPTICAL LINK MODULE	7)
ET200M				
1		6ES7 654-0XX08-1XA0	SIMATIC PCS 7 I/O SUBSYSTEM HOT SWAPPING, 8 I/O FOR ET200M	2)
DP/PA LINK				
1		6ES7 153-2BA82-0XB0	SIMATIC DP, INTERFACE DP/PA-LINK A. ET200M IM153-2 HF	3)
1		6ES7 157-0AC83-0XA0	SIMATIC DP, FIELD DEVICE LINK DP/PA COUPLER FDC 157-0 NON EX-VERSION	4)
1		6ES7 195-1GA00-0XA0	SIMATIC DP, RAIL FOR ET 200M 483 MM	5)
1		6ES7 195-7HA00-0XA0	SIMATIC DP, BUS UNIT FOR ET200M F. THE INTEGR.OF 1 PS A.1 IM153	
1		6ES7 195-7HF80-0XA0	SIMATIC DP, BUS UNIT BM DP/PA FOR EXPANDED TEMPERATURE RANGE	
FF LINK				
1		6ES7658-3MD18-0YA 5	SIMATIC PDM PCS 7-FF V8.1 (100 TAG)	8)
1		6ES7 153-2DA80-0XB0	SIMATIC FF LINK, IM 153-2 FF	
1		6ES7 157-0AC84-0XA0	Field Device Coupler FDC 157 for SIMATIC FF link	
1		6ES7 195-1GA00-0XA0	SIMATIC DP, RAIL FOR ET 200M 483 MM	5)
1		6ES7 195-7HA00-0XA0	SIMATIC DP, BUS UNIT FOR ET200M F. THE INTEGR.OF 1 PS A.1 IM153	
1		6ES7 195-7HF80-0XA0	SIMATIC DP, BUS UNIT BM DP/PA FOR EXPANDED TEMPERATURE RANGE	

Note

¹⁾ Please use the PCS 7 AS configurator, as the PCS 7 AS 410-5H is available in different versions, e.g. 24V DC or 110/230V AC. Notes regarding PROFIBUS DP:

- The maximum number of PROFIBUS DP slaves per master is 125 (typically 30 - 80)
- The maximum number of slaves per segment is 32, segments are separated from repeaters (diagnostics)

²⁾ ET200M, IM 153-2, diagnostics repeaters require a 24VDC power supply (not listed).

³⁾ Max. 64 field devices per DP/PA Link, IM 153-2 requires a 24VDC power supply (not listed).

⁴⁾ Notes regarding FDC 157-0:

- Max. 5 FDC 157-0 DP/PA couplers in a DP/PA link
- Max. 31 field devices per FDC 157-0. (typically 20 - 25)
- The maximum current supplied from FDC 157-0 is 1,000 mA
- The maximum PA segment length is 1,900 m (typically 500 - 1,000 m)

⁵⁾ Larger lengths are available.

⁶⁾ Max. 64 field devices per FF link (typically 8 - 12).

- Max. 1 FDC 157-0 DP/FF coupler (or 2 in a ring) in one FF link
- Max. 31 field devices per FDC 157. (typically 8 - 12)
- The maximum current supplied from FDC 157 is 1,000 mA
- The maximum FF segment length is 1,900 m (typically 500 - 1,000 m)

⁷⁾ OLM/G12 establishes a fault-tolerant PROFIBUS DP ring. OLM/G12 requires a 24 VDC power supply (not listed).

⁸⁾ Only one additional license is needed for FF communication if a PDM V8.1 license that includes routing exists. You can find this optional license in the PCS 7 catalog

14.3 Redundant DP-PA / DP-FF fieldbus

Figure 14-5

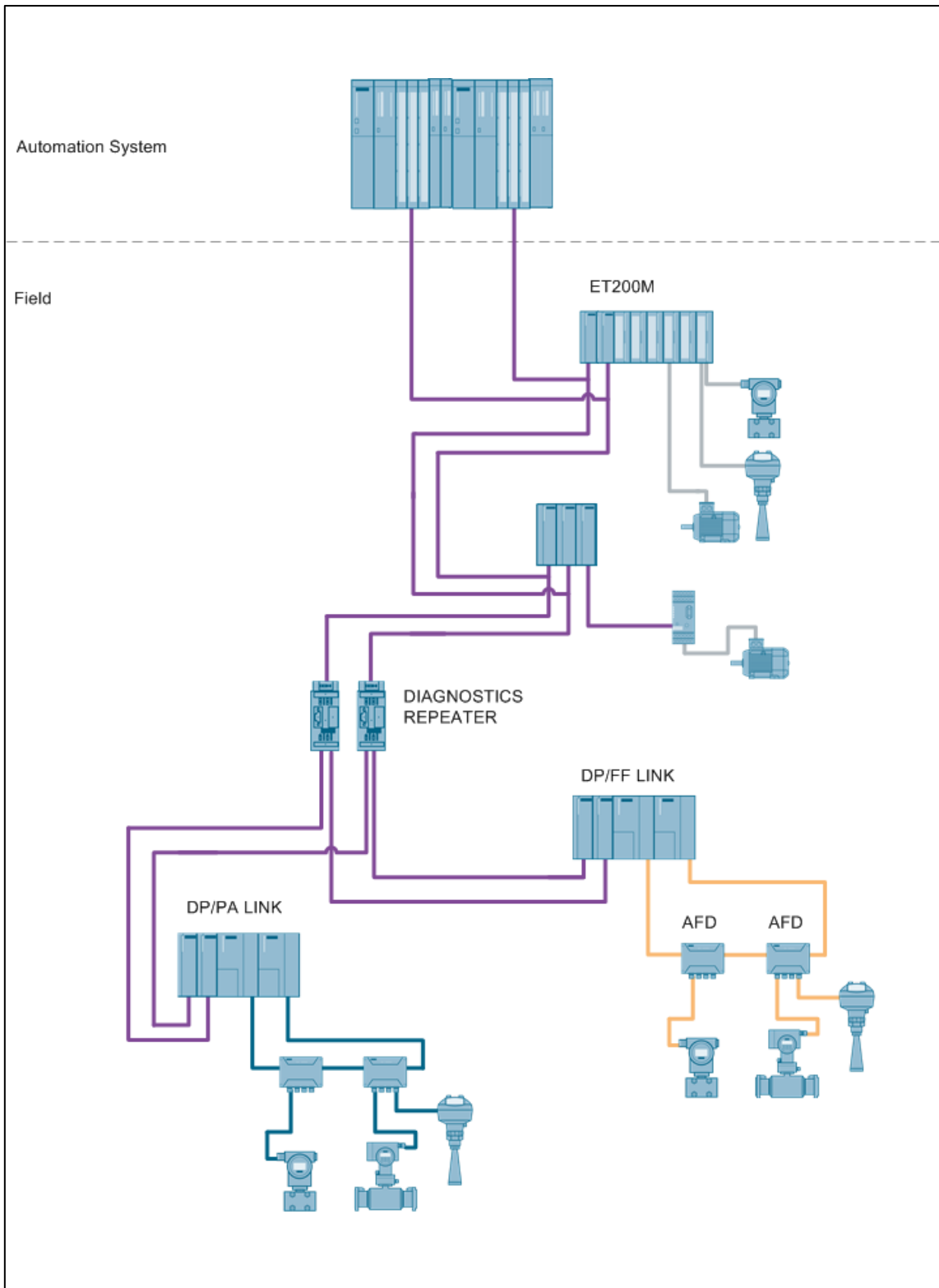

Copyright © Siemens AG 2013 All rights reserved

Bill of material for the redundant DP-PA / DP-FF fieldbus

Table 14–3

Required	Optional	Product number	Product description	Note
Automation system				
1		6ES7 656-6CL33-1CF0	SIMATIC PCS 7 REDUNDANCY AS, 2X CPU 410-5H, 2 DP-MODULE, 2X PROFINET-IO, SYSTEM EXPANSION CARD 500 PO, AS RT PO 100, 2 X 2 10M SYNC-MODULE AND 2 X 1M FO, 2 X CP443-1 IE/PN, 1 X UR2-H ALU RACK, 2 X UC 120/230V 10A RED. POWER SUPPLY	1)
2		6GK7 443-5DX05-0XE0	COMMUNICATION PROCESSOR CP443-5 EXTENDED	2)
ET200M				
1		6ES7 153-2AR03-0XA0	SIMATIC DP, ET200M-RED.-BUNDLE CONSISTING OF TWO IM153-2HF	3)
Y LINK				
1		6ES7 197-1LA11-0XA0	SIMATIC S7-400H, Y-LINK FOR CONNECTING SINGLE-CHANNEL DP SLAVES TO S7-400H	3)
DIAGNOSTICS REPEATER				
	2	6ES7972-0AA02-0XA0	SIMATIC DP, RS485 DIAGNOSTICS REPEATER	3)
DP/PA LINK				
2		6ES7 153-2BA82-0XB0	SIMATIC DP, INTERFACE DP/PA-LINK A. ET200M IM153-2 HF	4)
2		6ES7 157-0AC83-0XA0	SIMATIC DP, FIELD DEVICE LINK DP/PA COUPLER FDC 157-0 NON EX-VERSION	5)
1		6ES7 195-1GA00-0XA0	SIMATIC DP, RAIL FOR ET 200M 483 MM	6)
1		6ES7 195-7HD80-0XA0	SIMATIC DP, BUS UNIT BM IM 157 FOR EXPANDED TEMPERATURE RANGE	
1		6ES7 195-7HG80-0XA0	SIMATIC DP, BUS COUPLE BM DP/PA FOR 2 FDC 157-0 FOR REDUNDANT OPERATION	
2		6ES7 157-0AG81-0XA0	ACT. FIELD DISTRIBUTOR AFD FOR PROFIBUS PA RING	
1		6ES7157-0AG80-1XA1	10 protective caps for the unused connections on AFD	
Y-LINK and FF LINK				
	1	6ES7 658-3MD08-0YA5	SIMATIC PDM, SOFTWARE PCS 7 - FF V8.0	8)
2		6ES7 153-2DA80-0XB0	SIMATIC FF LINK, IM 153-2 FF	7)
2		6ES7 157-0AC84-0XA0	Field Device Coupler FDC 157 for SIMATIC FF link	
1		6ES7 195-1GA00-0XA0	SIMATIC DP, RAIL FOR ET 200M 483 MM	6)
1		6ES7 195-7HD80-0XA0	SIMATIC DP, BUS UNIT BM IM 157 FOR EXPANDED TEMPERATURE RANGE	
1		6ES7 195-7HG80-0XA0	SIMATIC DP, BUS COUPLE BM DP/PA FOR 2 FDC 157-0 FOR REDUNDANT OPERATION	
2		6ES7 157-0AG81-0XA0	ACTIVE FIELD DISTRIBUTOR AFD4 FOR FF RING	

Note

¹⁾ Please use the PCS 7 AS configurator, as the PCS 7 AS 410-5H is available in different versions, e.g. 24V DC or 110/230V AC.

²⁾ Note regarding CP443-5 Extended:

- The maximum number of PROFIBUS DP slaves per master is 125 (typically 30 - 80)
- The maximum number of slaves per segment is 32, segments are separated from repeaters (diagnostics)

³⁾ ET200M, IM 153-2, diagnostics repeaters require a 24VDC power supply (not listed).

⁴⁾ Max. 64 field devices per DP/PA Link, IM 153-2 requires a 24VDC power supply (not listed).

⁵⁾ Notes regarding FDC 157-0:

- Max. one pair of redundant FDC 157-0 per DP/PA link and 3 single FDC 157-0
- Max. 31 field devices per redundant pair of FDC 157-0 (typically 20 - 25)
- The maximum current supplied from FDC 157-0 is 1,000 mA
- The maximum PA segment length is 1,900 m (typically 500 - 1,000 m)

⁶⁾ Larger lengths are available.

⁷⁾ Max. 64 field devices per FF link (typically 8 - 12).

- Max. 1 FDC 157-0 DP/FF coupler (or 2 in a ring) in one FF link
- Max. 31 field devices per FDC 157 (typically 8 - 12)
- The maximum current supplied from FDC 157 is 1,000 mA
- The maximum FF segment length is 1,900 m (typically 500 - 1,000 m)

⁸⁾ Only one additional license is needed for FF communication if a PDM V8.1 license that includes routing exists. You can find this optional license in the PCS 7 catalog.

14.4 Redundant optical DP-PA / DP-FF fieldbus

Figure 14-6

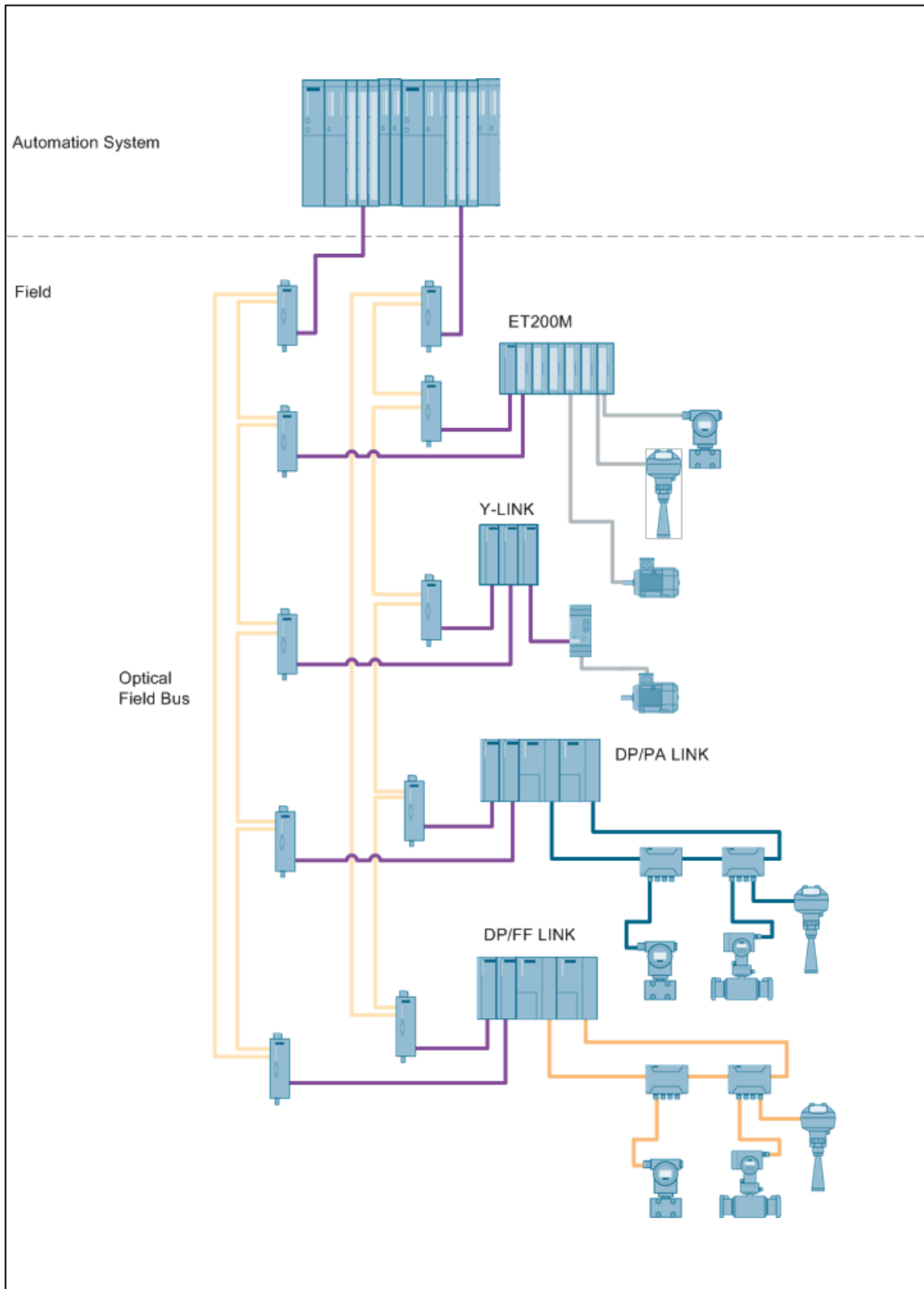

Copyright © Siemens AG 2013 All rights reserved

Bill of material for the redundant optical DP-PA / DP-FF fieldbus

Table 14–4

Required	Optional	Product number	Product description	Note
Automation system				
1		6ES7 656-6CL33-1CF0	SIMATIC PCS 7 REDUNDANCY AS, 2X CPU 410-5H, 2 DP-MODULE, 2X PROFINET-IO, SYSTEM EXPANSION CARD 500 PO, AS RT PO 100, 2 X 2 10M SYNC-MODULE AND 2 X 1M FO, 2 X CP443-1 IE/PN, 1 X UR2-H ALU RACK, 2 X UC 120/230V 10A RED. POWER SUPPLY	1)
2		6GK7 443-5DX05-0XE0	COMMUNICATION PROCESSOR CP443-5 EXTENDED	2)
OPTICAL FIELDBUS				
10		6GK1 503-3CB00	PROFIBUS OLM/G12 V4.0 OPTICAL LINK MODULE	8)
ET200M				
1		6ES7 153-2AR03-0XA0	SIMATIC DP, ET200M-RED.-BUNDLE CONSISTING OF TWO IM153-2HF	3)
Y LINK				
2		6ES7 197-1LA11-0XA0	SIMATIC S7-400H, Y-LINK FOR CONNECTING SINGLE-CHANNEL DP SLAVES TO S7-400H	3)
DP/PA LINK				
2		6ES7 153-2BA82-0XB0	SIMATIC DP, INTERFACE DP/PA-LINK A. ET200M IM153-2 HF	4)
2		6ES7 157-0AC83-0XA0	SIMATIC DP, FIELD DEVICE LINK DP/PA COUPLER FDC 157-0 NON EX-VERSION	5)
1		6ES7 195-1GA00-0XA0	SIMATIC DP, RAIL FOR ET 200M 483 MM	6)
1		6ES7 195-7HD80-0XA0	SIMATIC DP, BUS UNIT BM IM 157 FOR EXPANDED TEMPERATURE RANGE	
1		6ES7 195-7HG80-0XA0	SIMATIC DP, BUS COUPLE BM DP/PA FOR 2 FDC 157-0 FOR REDUNDANT OPERATION	
2		6ES7 157-0AG81-0XA0	ACTIV- FIELD DISTRIBUTOR AFD4 FOR PROFIBUS PA RING	
1		6ES7157-0AG80-1XA1	10 protective caps for the unused connections on AFD	
FF LINK				
	1	6ES7 658-3MD08-0YA5	SIMATIC PDM, SOFTWARE PCS 7 - FF V8.0	9)
2		6ES7 153-2DA80-0XB0	SIMATIC FF LINK, IM 153-2 FF	7)
2		6ES7 157-0AC84-0XA0	Field Device Coupler FDC 157 for SIMATIC FF link	
1		6ES7 195-1GA00-0XA0	SIMATIC DP, RAIL FOR ET 200M 483 MM	6)
1		6ES7 195-7HD80-0XA0	SIMATIC DP, BUS UNIT BM IM 157 FOR EXPANDED TEMPERATURE RANGE	
1		6ES7 195-7HG80-0XA0	SIMATIC DP, BUS COUPLE BM DP/PA FOR 2 FDC 157-0 FOR REDUNDANT OPERATION	
2		6ES7 157-0AG81-0XA0	ACTIVE FIELD DISTRIBUTOR AFD4 FOR FF RING	

Note

- ¹⁾ Please use the PCS 7 AS configurator, as the PCS 7 AS 410-5H is available in different versions, e.g. 24V DC or 110/230V AC.
- ²⁾ Note regarding CP443-5 Extended:
 - The maximum number of PROFIBUS DP slaves per master is 125 (typically 30 - 80)
 - The maximum number of slaves per segment is 32, segments are separated from repeaters (diagnostics)
- ³⁾ ET200M, IM 153-2, diagnostics repeaters require a 24VDC power supply (not listed).
- ⁴⁾ Max. 64 field devices per DP/PA Link, IM 153-2 requires a 24VDC power supply (not listed).
- ⁵⁾ Notes regarding FDC 157-0:
 - Max. 5 FDC 157-0 DP/PA couplers in a DP/PA link
 - Max. 31 field devices per FDC 157-0 (typically 20 - 25)
 - The maximum current supplied from FDC 157-0 is 1,000 mA
 - The maximum PA segment length is 1,900 m (typically 500 - 1,000 m)
- ⁶⁾ Larger lengths are available.
- ⁷⁾ Max. 64 field devices per FF link (typically 8 - 12).
 - Max. 1 FDC 157-0 DP/FF coupler (or 2 in a ring) in one FF link
 - Max. 31 field devices per FDC 157 (typically 8 - 12)
 - The maximum current supplied from FDC 157 is 1,000 mA
 - The maximum FF segment length is 1,900 m (typically 500 - 1,000 m)
- ⁸⁾ OLM/G12 establishes a fault-tolerant PROFIBUS DP ring. OLM/G12 requires a 24VDC power supply (not listed).
- ⁹⁾ Only one additional license is needed for FF communication if a PDM V8.1 license that includes routing exists. You can find this optional license in the PCS 7 catalog.

14.5 PROFINET IO fieldbus of a single automation system

On H systems, the PROFINET IO network can only be operated through the internal Ethernet interface. It is not possible to operate it through the external Ethernet CP443-1EX30.

Figure 14-7

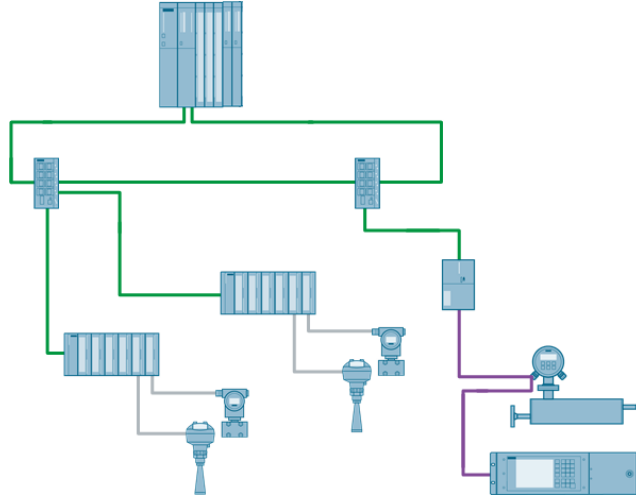

Bill of material for the single PROFINET IO fieldbus

Table 14-5

Required	Optional	Product number	Product description	Note
Automation system				
1		6ES7 654-6CL03-3BF0	SIMATIC PCS 7 SINGLE AS, CPU 410-5H, 1X DP-MODULE, 1x PROFINET-IO, SYSTEM EXPANSIONS CARD 500 PO, AS RT PO 100, CP443-1IE, UR2 ALU RACK, 1 X UC 120/230V 10A POWER SUPPLY	1) 3) 5) 9)
ET200M				
2		6ES7 153-4BA00-0XB0	SIMATIC ET 200M (IM 153-4 PN HF) SIMATIC DP, ET200M-RED.-BUNDLE CONSISTING OF TWO IM153-2HF	2) 5)
Network components				
2		6GK5 208-0BA10-2AA3	SIMATIC NET SCALANCE X208, MANAGED IE SWITCH, 8 X 10/100MBIT/S	8)
6		6XV1 870-3QH60	SIMATIC NET INDUSTRIAL ETHERNET TP CORD CABLE RJ45/RJ45, 6M	
Network components				
1		6GK1411-5AB00	IE/PB Link PN IO	7)

Note

- 1) Please use the PCS 7 AS configurator, as the PCS 7 AS 410-5H is available in different versions, e.g. 24V DC or 110/230V AC.
- 2) ET200M, IM 153-2xxx 24VDC power supply (not listed).
- 3) Max. 5 CPs with max. 128 IO devices per CP interface.
- 4) Max. 250 IO devices per onboard CPU interface.
- 5) Max. 50 PROFINET IO devices in an MRP ring that includes ET200M, SCALANCE X, CPU and CPs.
- 6) SCALANCE switch requires a 24VDC power supply (not listed).
- 7) PROFIBUS DP devices and lower-level PROFIBUS PA devices (PA coupler) are only supported by compact devices.
- 8) All ring devices must support MRP.
- 9) Max. 64 IO switches in series (latency).

14.6 PROFINET IO fieldbus in a high-availability automation system

On H systems, the PROFINET IO network can only be operated through the internal Ethernet interface. It is not possible to operate it through the external Ethernet CP443-1EX30. The PROFINET IO network is operated with system redundancy as an "open Ethernet ring" (system redundant line) to increase availability of the remote IO stations.

Figure 14-8

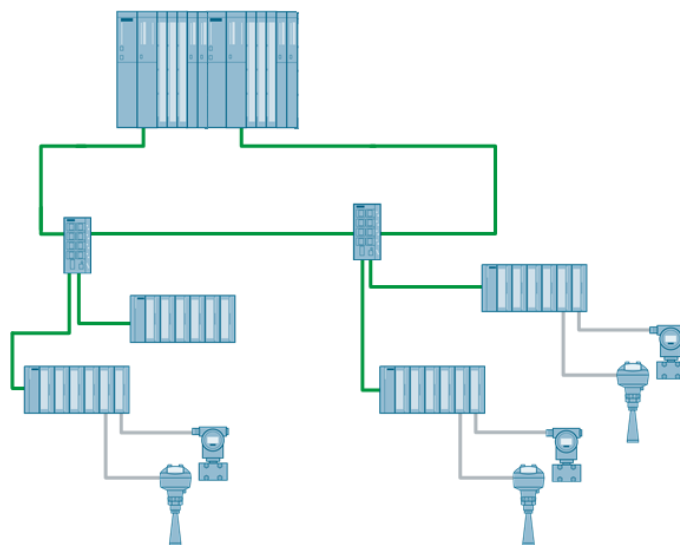

Bill of material for the single PROFINET IO fieldbus

Table 14–6

Required	Optional	Product number	Product description	Note
Automation system				
1		6ES7 656-6CL33-1CF0	SIMATIC PCS 7 REDUNDANCY AS, 2X CPU 410-5H, 2 DP-MODULE, 2X PROFINET-IO, SYSTEM EXPANSION CARD 500, AS RT PO 100, 2 X 2 10M SYNC-MODULE AND 2 X 1M FO, 2 X CP443-1 IE/PN, 1 X UR2-H ALU RACK, 2 X UC 120/230V 10A RED. POWER SUPPLY	1) 2) 4) 5)
ET200M				
4		6ES7 153-4BA00-0XB0	SIMATIC ET 200M (IM 153-4 PN HF)	3)
Network components				
2		6GK5 208-0BA10-2AA3	SIMATIC NET SCALANCE X208, MANAGED IE SWITCH, 8 X 10/100MBIT/S	6)
7		6XV1 870-3QH60	SIMATIC NET INDUSTRIAL ETHERNET TP CORD CABLE RJ45/RJ45, 6M	

Note

- 1) Please use the PCS 7 AS configurator, as the PCS 7 AS 410-5H is available in different versions, e.g. 24V DC or 110/230V AC.
- 2) Only devices that can support system redundancy are operated at the H system as redundant. Devices that don't support system redundancy can only be allocated to an H CPU.
- 3) ET200M, IM 153-2xxx 24VDC power supply (not listed).
- 4) Max. 250 IO devices per onboard CPU interface.
- 5) Max. 64 IO switches in series (latency).
- 6) SCALANCE switch requires a 24VDC power supply (not listed).

15 Network architecture

Star structure

The robust SCALANCE network components, active and managed switches can be used to build cost-effective networking topologies for a large number of devices.

SCALANCE offers a wide range of components needed to build star structures with a large number of ports. If multiple switches are needed to ensure a high number of ports or to enable the spatial distribution to enable the switches, then we suggest to connect the switches as a fault-tolerant ring.

Fault-tolerant ring

A unique redundancy manager concept enables the administration of several SCALANCE switch faults in a ring backbone for optical, electrical or mixed media process without interrupting the network communication. This ability can be found in the complete series of SCALANCE switches (from SCALANCE X200), supplied with SIMATIC PCS 7.

Double redundant bus

SIMATIC PCS 7 provides redundancy from the OS client right through to the field bus connection. The network communication between the OS clients and OS servers as well as between OS servers and the AS can reach the highest level of availability when each PC and the automation system (two network interfaces per PC and AS) are connected in a ring structure to the separate fault-tolerant network.

Fault-tolerant ring 1GB

Applications for which the backbone data transmission rate cannot be compromised benefit from the large network backbone switches offered by SCALANCE 1GB. These high-performance switches deliver the functionality of redundancy management, where the fault-tolerant ring topologies can be built with a simple or double redundancy.

15.1 Star architectures

Figure 15-1

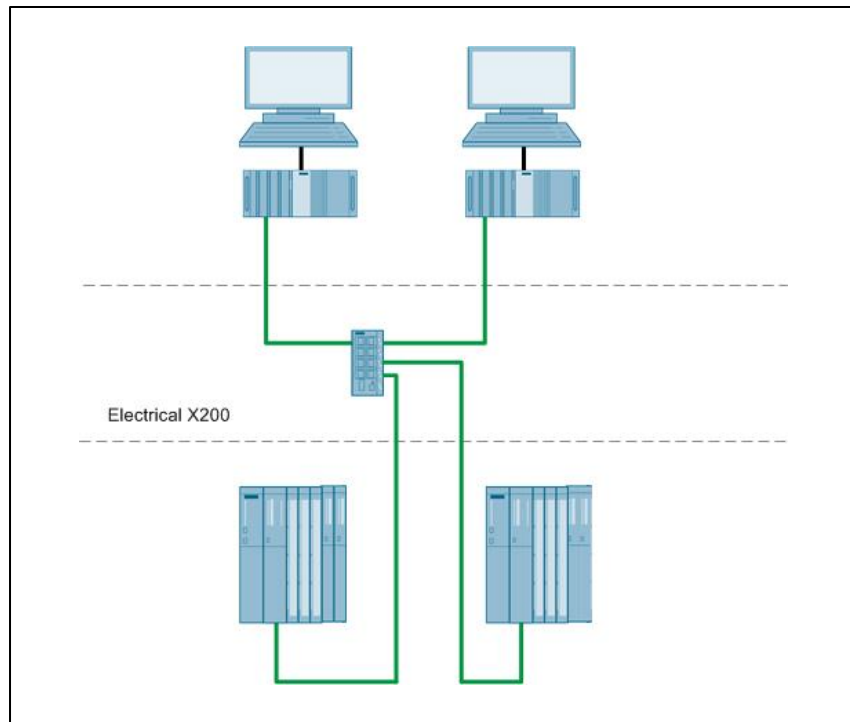

Bill of material for star architectures

Table 15–1

Required	Optional	Product number	Product description	Note
Electrical X200				
1		6GK5 208-0BA10-2AA3	SIMATIC NET SCALANCE X208, MANAGED IE SWITCH, 8 X 10/100MBIT/S	¹⁾
4		6XV1 870-3QH60	SIMATIC NET INDUSTRIAL ETHERNET TP CORD CABLE RJ45/RJ45, 6M	

Note ¹⁾ SCALANCE switch requires a 24VDC power supply (not listed).

15.2 Fault-tolerant ring architectures

15.2.1 High speed ring fault tolerance

Fault tolerant SCALANCE rings are used to provide multiple communication paths between switches, so that if one of the paths fails, the backup path is activated to ensure communication. Unlike the "spanning-tree" technology, which provides similar functionality, SCALANCE switches reconfigure the existing communication paths fast enough to avoid that connected systems (controllers, servers, clients) suffer a loss of communication. High-speed ring monitoring and reconfiguration is achieved when a SCALANCE switch assumes the role of redundancy manager.

Ring connections between switches can be made via electrical or optical cable connections.

Figure 15-2

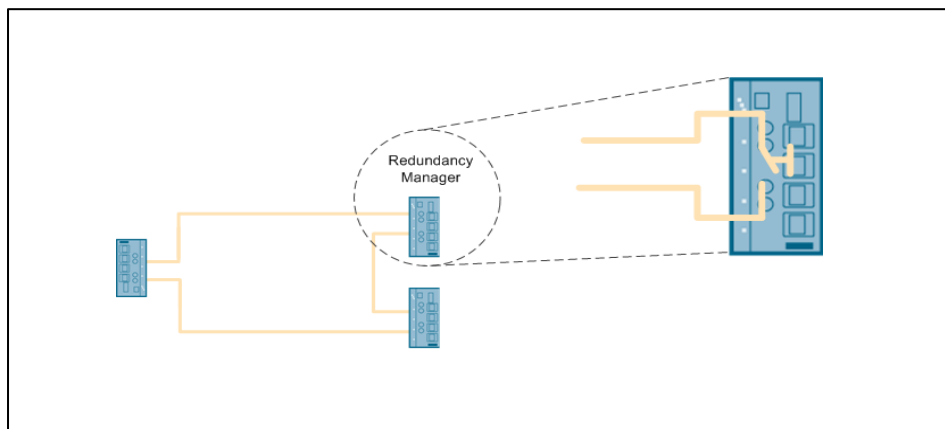

The redundancy manager acts as a switch that opens the Ethernet ring at a predetermined position and controls the line status. If an error occurs in the line, the redundancy manager recognizes this, closes the switch and re-establishes the communication.

15.2.2 Ring connectivity, standby redundancy

To connect two separate fault-tolerant Ethernet rings in a redundant way, there is a second high-speed redundancy function. Although it is required to have two connections between the rings for redundancy, only one connection can be active. To achieve this, one of the two rings to be coupled is provided with two switches that support this so-called stand-by redundancy. In this concept, two parallel point-to-point connections monitor each other to ensure that the stand-by connection is activated when the active link fails. This is achieved by configuring a SCALANCE switch as standby master and a second SCALANCE switch as standby slave.

Figure 15-3

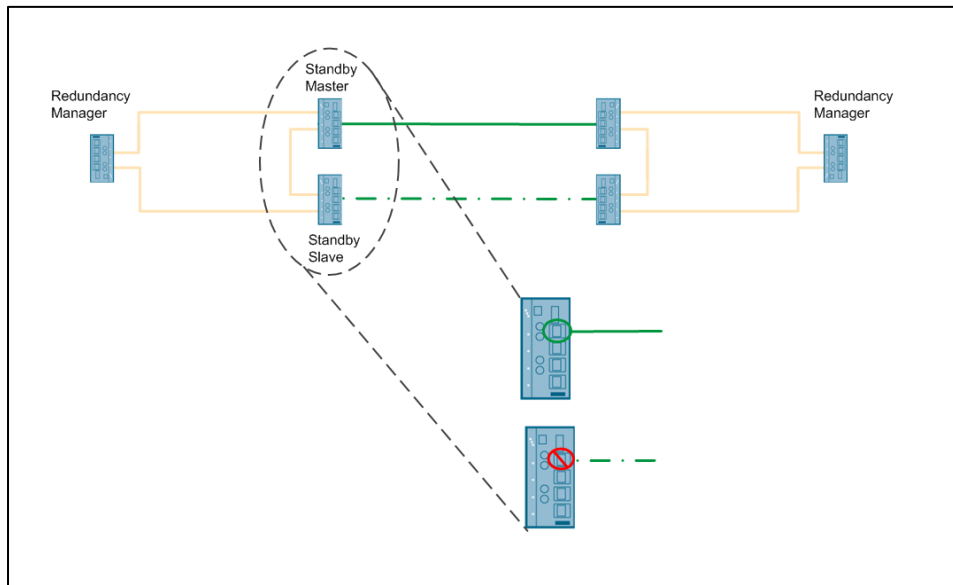

The standby master and standby slave are logically linked. The standby master activates its link and the standby slave deactivates its own. Both switches monitor each other's status and the standby slave becomes active if the active connection fails. The process of activating the standby slaves happens so fast that it does not come to a breakdown of communication between the connected systems (controllers, servers, clients).

15.3 Fault-tolerant ring architectures in fiber-optic cable

Figure 15-4

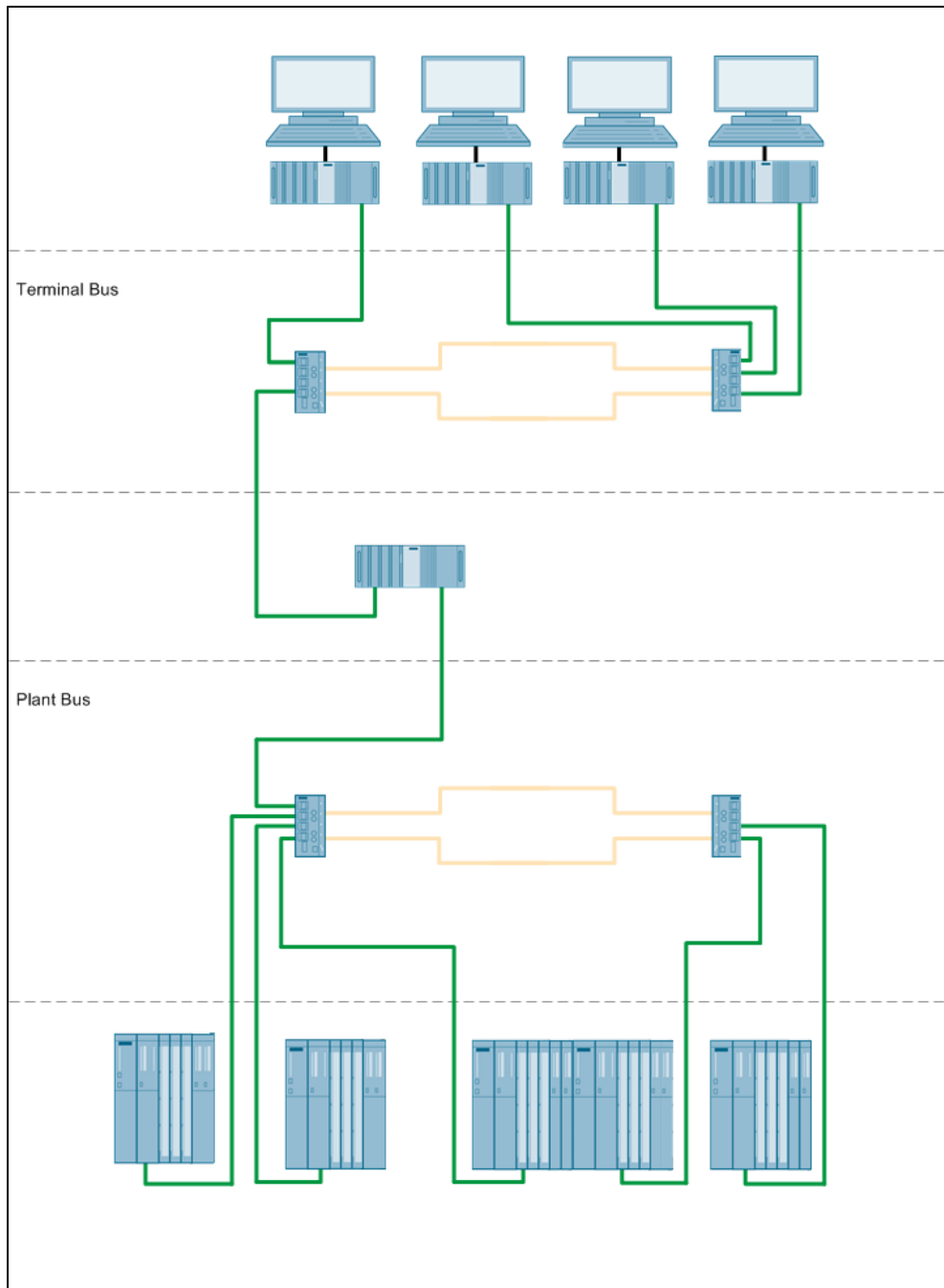

Copyright © Siemens AG 2013 All rights reserved

Bill of material for the fault-tolerant ring architecture in fiber-optic cable

Table 15–2

Required	Optional	Product number	Product description	Note
Terminal bus				
2		6GK5 204-2BB10-2AA3	SIMATIC NET SCALANCE X204-2, MANAGED IE SWITCH, 4 X 10/100MBIT/S	1)
2		6XV1 820-5BN10	SIMATIC NET, FIBER OPTIC CABLE, 4 BFOC CONNECTORS, 10M	
5		6XV1 870-3QH60	SIMATIC NET INDUSTRIAL ETHERNET TP CORD CABLE RJ45/RJ45, 6M	
System bus				
2		6GK5 204-2BB10-2AA3	SIMATIC NET SCALANCE X204-2, MANAGED IE SWITCH, 4 X 10/100MBIT/S	1)
2		6XV1 820-5BN10	SIMATIC NET, FIBER OPTIC CABLE, 4 BFOC CONNECTORS, 10M	
6		6XV1 870-3QH60	SIMATIC NET INDUSTRIAL ETHERNET TP CORD CABLE RJ45/RJ45, 6M	

Note

¹⁾ SCALANCE switch requires a 24VDC power supply (not listed).

15.4 Electrical fault-tolerant ring architectures

Figure 15-5

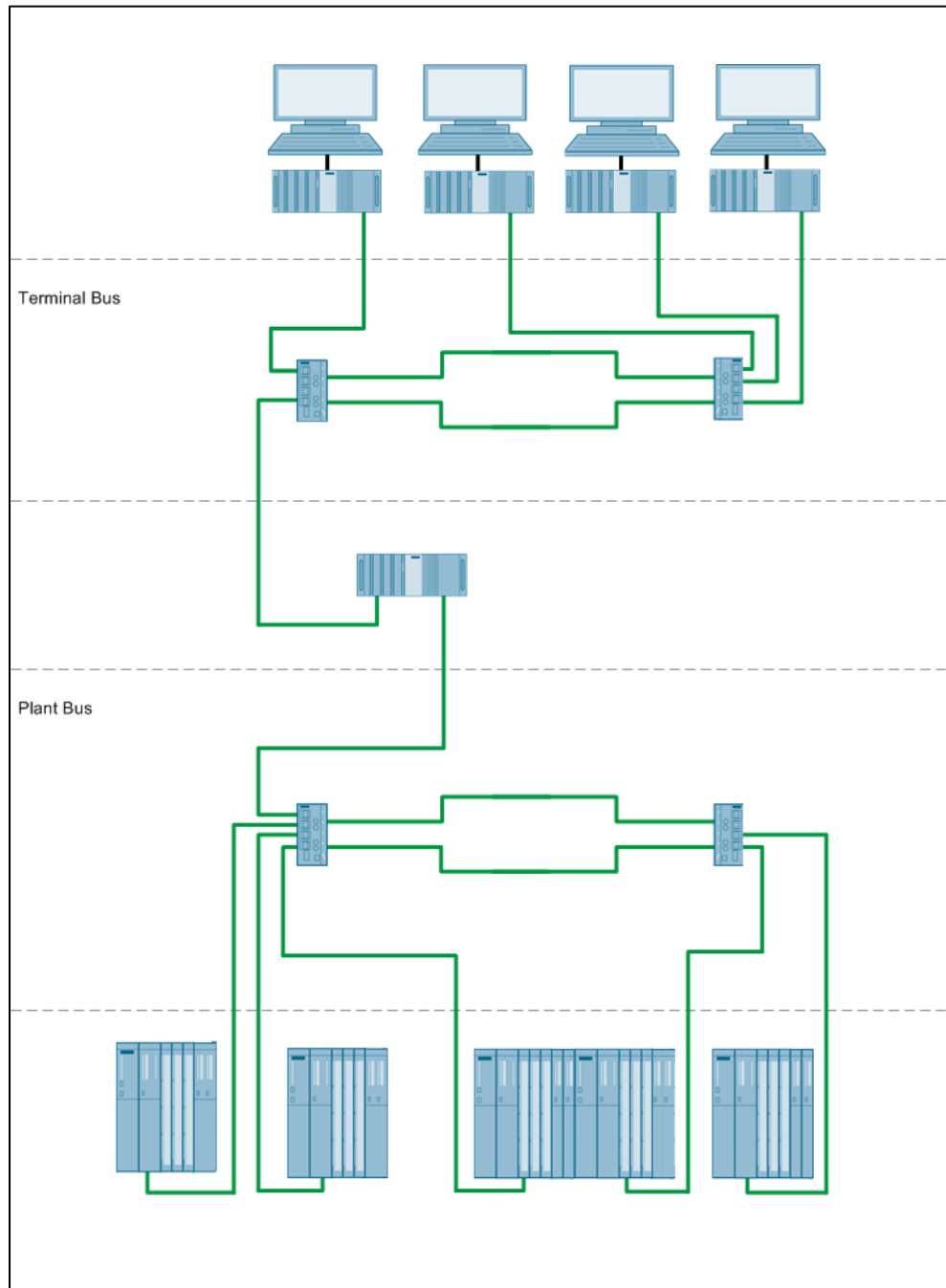

Copyright © Siemens AG 2013 All rights reserved

Bill of material for the electrical fault-tolerant ring architecture

Table 15–3

Required	Optional	Product number	Product description	Note
Terminal bus				
2		6GK5 208-0BA10-2AA3	SIMATIC NET SCALANCE X208, MANAGED IE SWITCH, 8 X 10/100MBIT/S	1)
7		6XV1 870-3QH60	SIMATIC NET INDUSTRIAL ETHERNET TP CORD CABLE RJ45/RJ45, 6M	
System bus				
2		6GK5 208-0BA10-2AA3	SIMATIC NET SCALANCE X208, MANAGED IE SWITCH, 8 X 10/100MBIT/S	1)
8		6XV1 870-3QH60	SIMATIC NET INDUSTRIAL ETHERNET TP CORD CABLE RJ45/RJ45, 6M	

Note ¹⁾ SCALANCE switch requires a 24VDC power supply (not listed).

15.5 (Double) redundant bus architectures

Figure 15-6

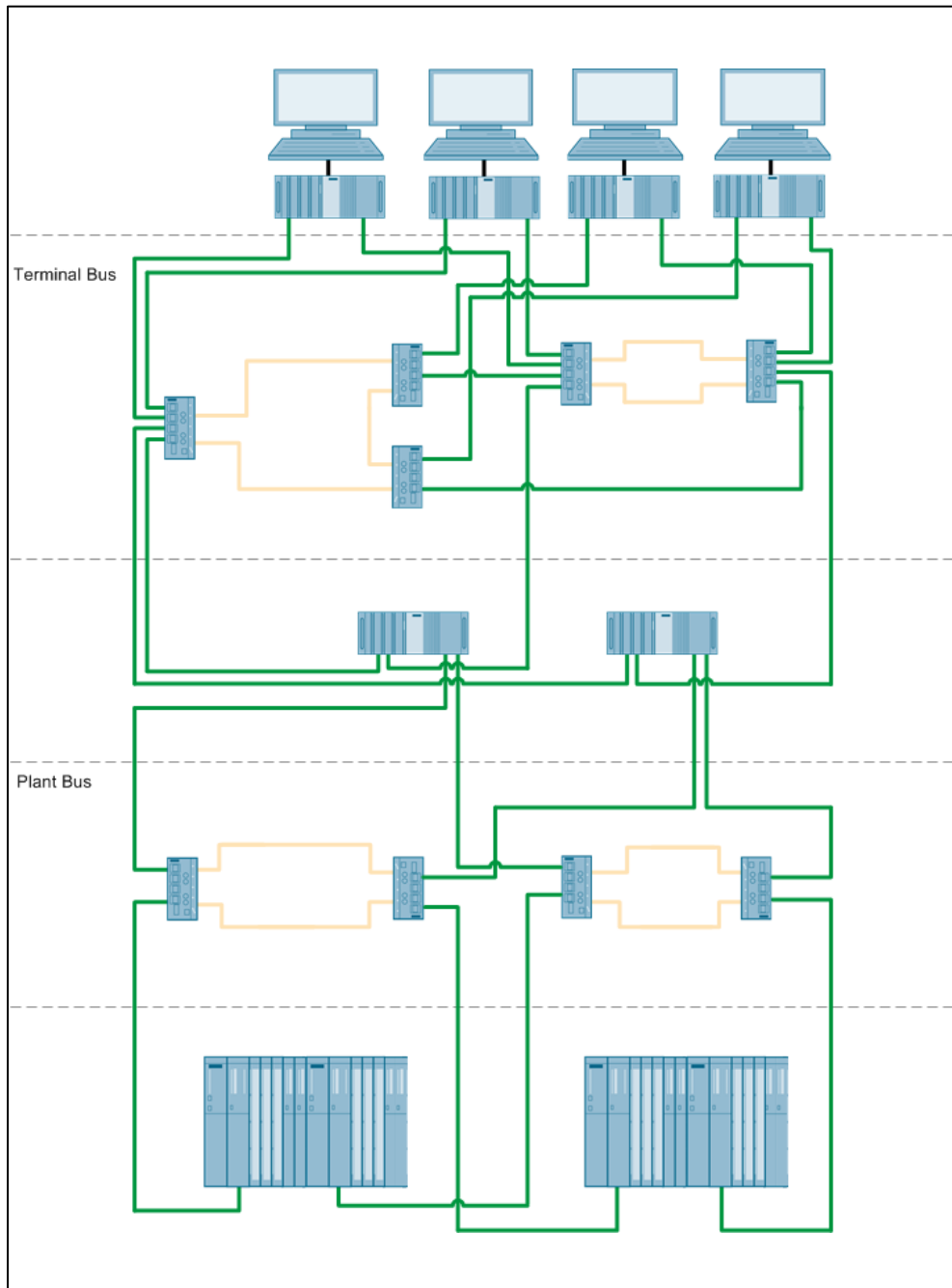

Bill of material for (double) redundant bus architectures

Table 15–4

Required	Optional	Product number	Product description	Note
Terminal bus				
2		6GK5 202-2BB00-2BA3	SIMATIC NET SCALANCE X202-2IRT MANAGED IE IRT SWITCH, 2 X 10/100MBIT/S	¹⁾
3		6GK5 204-2BB10-2AA3	SIMATIC NET SCALANCE X204-2, MANAGED IE SWITCH, 4 X 10/100MBIT/S	¹⁾
5		6XV1 820-5BN10	SIMATIC NET, FIBER OPTIC CABLE, 4 BFOC CONNECTORS, 10M	
14		6XV1 870-3QH60	SIMATIC NET INDUSTRIAL ETHERNET TP CORD CABLE RJ45/RJ45, 6M	
System bus				
4		6GK5 204-2BB10-2AA3	SIMATIC NET SCALANCE X204-2, MANAGED IE SWITCH, 4 X 10/100MBIT/S	¹⁾
4		6XV1 820-5BN10	SIMATIC NET, FIBER OPTIC CABLE, 4 BFOC CONNECTORS, 10M	
8		6XV1 870-3QH60	SIMATIC NET INDUSTRIAL ETHERNET TP CORD CABLE RJ45/RJ45, 6M	

Note ¹⁾ SCALANCE switch requires a 24VDC power supply (not listed).

15.6 Fault-tolerant ring 1GB

Figure 15-7

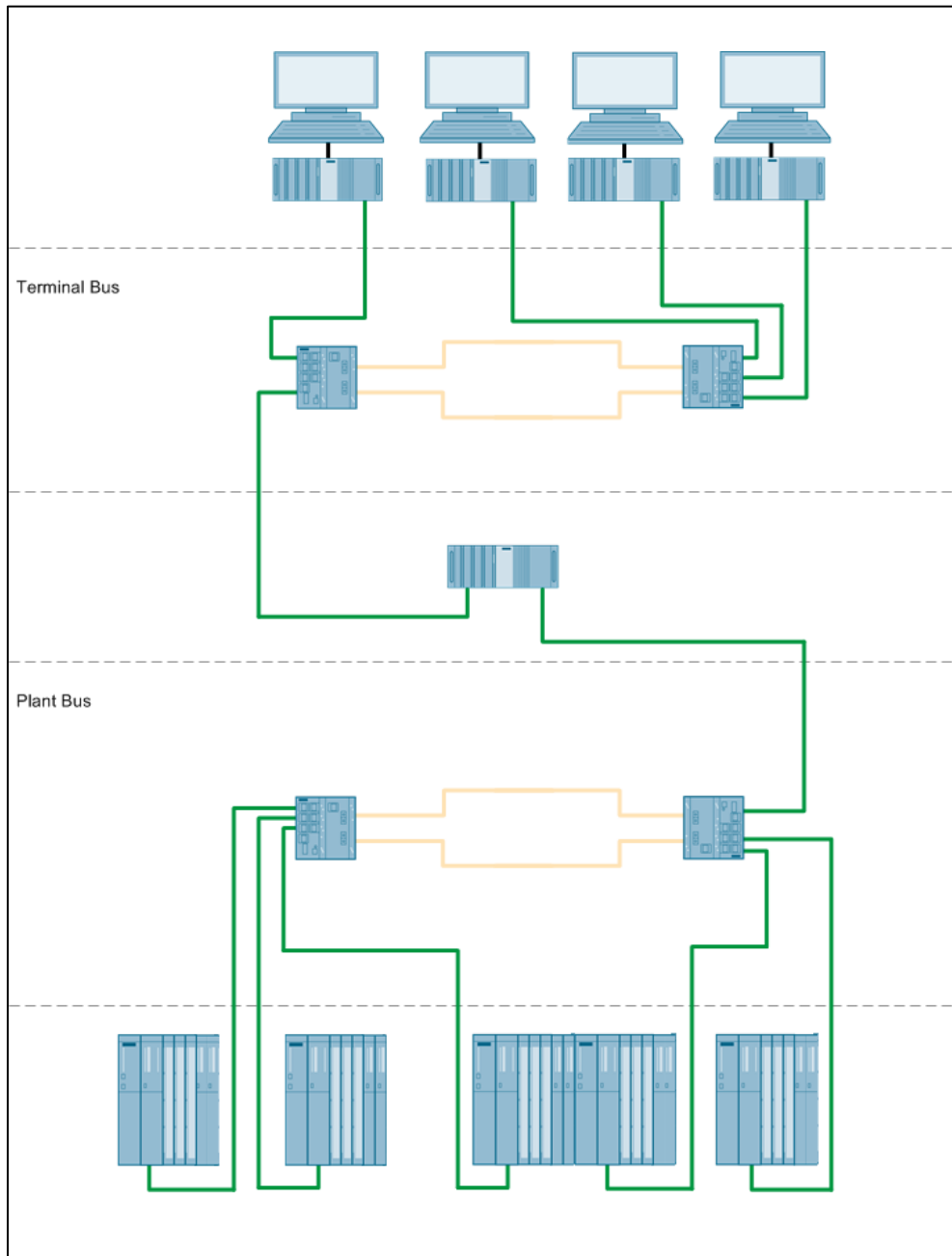

Copyright © Siemens AG 2013 All rights reserved

Bill of material for the fault-tolerant ring 1GB

Table 15-5

Required	Optional	Product number	Product description	Note
Terminal bus				
2		6GK5 308-2FL00-2AA3	SIMATIC NET SCALANCE X308-2, MANAGED PLUS IE SWITCH, 2 X 1000MBIT/S	¹⁾
2		6XV1 873-6AN10	SIMATIC NET FO STANDARD CABLE, 10M	
5		6XV1 870-3QH60	SIMATIC NET INDUSTRIAL ETHERNET TP CORD CABLE RJ45/RJ45, 6M	
System bus				
2		6GK5 308-2FL00-2AA3	SIMATIC NET SCALANCE X308-2, MANAGED PLUS IE SWITCH, 2 X 1000MBIT/S	¹⁾
2		6XV1 873-6AN10	SIMATIC NET FO STANDARD CABLE, 10M	
6		6XV1 870-3QH60	SIMATIC NET INDUSTRIAL ETHERNET TP CORD CABLE RJ45/RJ45, 6M	

Note ¹⁾ SCALANCE switch requires a 24VDC power supply (not listed).

15.7 Redundancy concept - system bus

15.7.1 Introduction

Besides the above described fault-tolerant ring and double ring concepts, PCS 7 also provides flexible redundancy solutions for communication via system bus between the OS and AS (controllers). For redundant communication it is required to have SIMATIC S7-400H CPUs (single or redundant), SCALANCE X network components and the communication processor CP1623 for the PCs involved.

15.7.2 Single-user AS 41x-x-1H automation system

Single-user AS 41x-x-1H systems are composed of one S7-41xH CPU. A station with two CP443-1 Ethernet communications processors can be equipped to support redundant communication. The table below shows the different redundancy configurations.

- Concept 1, single network, single OS server/single-user network connection, two communication paths
 - one CP1623 in the OS Server, Single-user station
 - two CP443-1 communications processors
 - star network or fault-tolerant ring
- Concept 2, single network, redundant OS server/single-user network connection, two communication paths
 - two CP1623 in the OS Server, Single-user station
 - two CP443-1 communications processors
 - star network or fault-tolerant ring
- Concept 3, (double) redundant network, redundant OS server/single-user network connection, two communication paths
 - two CP1623 in the OS Server, Single-user station
 - two CP443-1 communications processors
 - double fault-tolerant ring

Figure 15-8

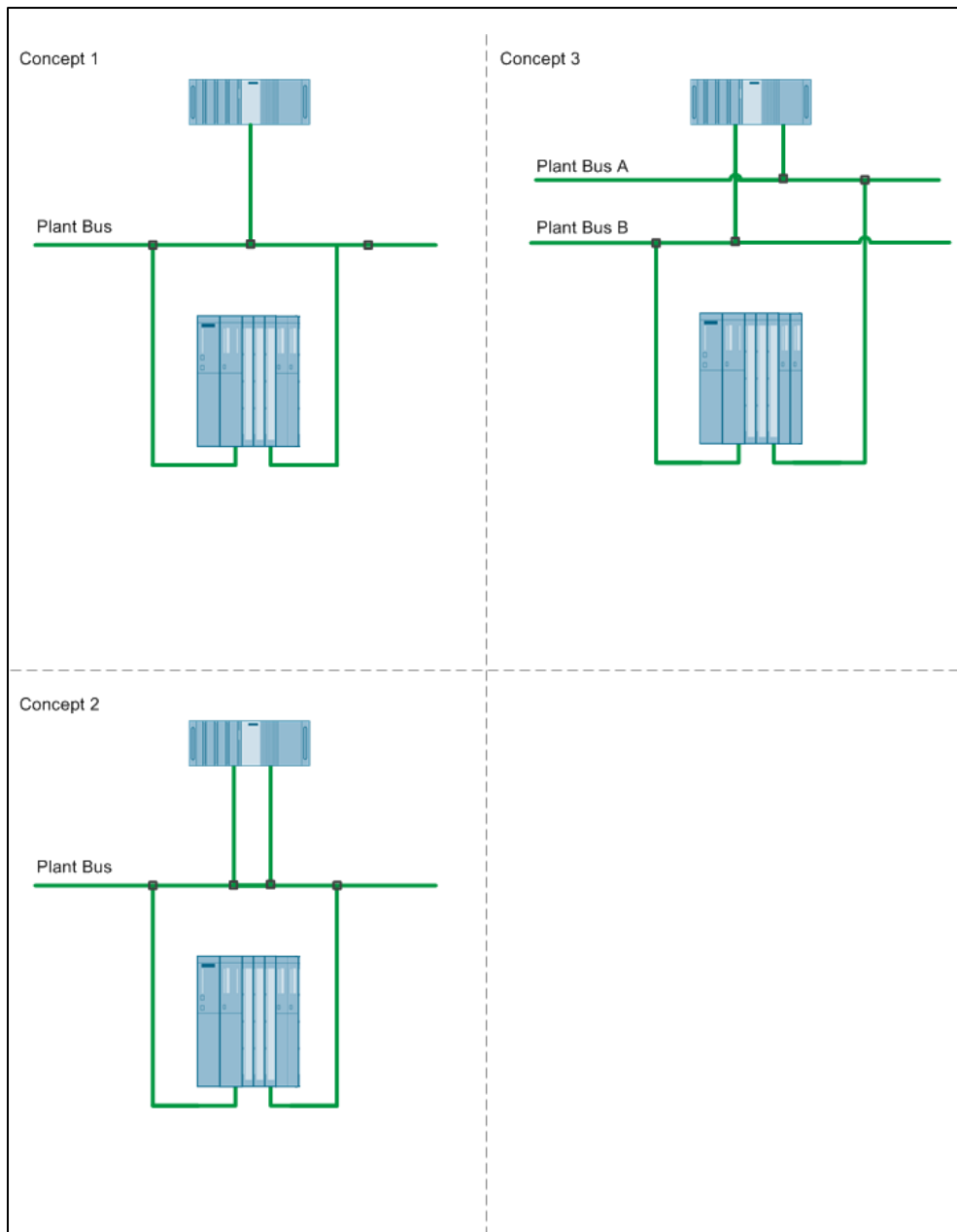

Bill of material for the single-user AS 41x-x-1H automation system

- Concept 1

Table 15–6

Required	Optional	Product number	Product description	Note
Automation system				
1		6ES7 654-6CL03-3BF0	SIMATIC PCS 7 SINGLE AS, CPU 410-5H, 1X DP-MODULE, 1x PROFINET-IO, SYSTEM EXPANSIONS CARD 500 PO, AS RT PO 100, CP443-1IE, UR2 ALU RACK, 1 X UC 120/230V 10A POWER SUPPLY	1)
Engineering System and Operator System				
1		6GK1 716-0HB08-1AC0	SIMATIC NET, S7-REDCONNECT POWERPACK	2)

- Concept 2, concept 3

Table 15–7

Required	Optional	Product number	Product description	Note
Automation system				
1		6ES7 654-6CL03-3BF0	SIMATIC PCS 7 SINGLE AS, CPU 410-5H, 1X DP-MODULE, 1x PROFINET-IO, SYSTEM EXPANSIONS CARD 500 PO, AS RT PO 100, CP443-1IE, UR2 ALU RACK, 1 X UC 120/230V 10A POWER SUPPLY	
Engineering System and Operator System				
1		6GK1 716-0HB08-1AC0	SIMATIC NET, S7-REDCONNECT POWERPACK	1)
1		6GK1 162-3AA00	SIMATIC NET COMMUNICATION PROCESSOR CP 1623 PCI EXPRESS	1) 2)

Note

SCALANCE switch and network components must be added; see the description of the network topology in this chapter to select the appropriate configuration and components.

- 1) REDCONNECT upgrade and CP1623 are needed for every Operator System and Engineering System integrated in the system bus.
- 2) The bill of material is based on the assumption that the selected Operator System and Engineering System hardware is equipped with a CP1623 (industrial Ethernet version of the hardware); only additional CP1623 communications processors are listed.

15.7.3 Redundant AS 410-5H automation system

Redundant AS 410-5H automation systems consist of two redundant 410-5H CPUs. They can be equipped with two redundant CP443-1 or 4 redundant CP443-1 communications processors. The table below shows the different redundancy configurations:

- Concept 1, single network, single OS server/single-user network connection, two communication paths
 - one CP1623 in the OS Server, Single-user station
 - two CP443-1 communications processors or onboard Ethernet interface
 - star network or fault-tolerant ring
- Concept 2, single network, redundant OS server/single-user network connection, four communication paths
 - two CP1623 in the OS Server, Single-user station
 - two CP443-1 communications processors or onboard Ethernet interface
 - star network or fault-tolerant ring
- Concept 3, (double) redundant network, redundant OS server/single-user network connection, two communication paths
 - two CP1623 in the OS Server, Single-user station
 - two CP443-1 communications processors or onboard Ethernet interface
 - (double) redundant fault-tolerant rings
- Concept 4, (double) redundant network, redundant OS server/single-user network connection, four communication paths
 - two CP1623 in the OS Server, Single-user station
 - four CP443-1 communications processors
 - (double) redundant fault-tolerant rings

Figure 15-9

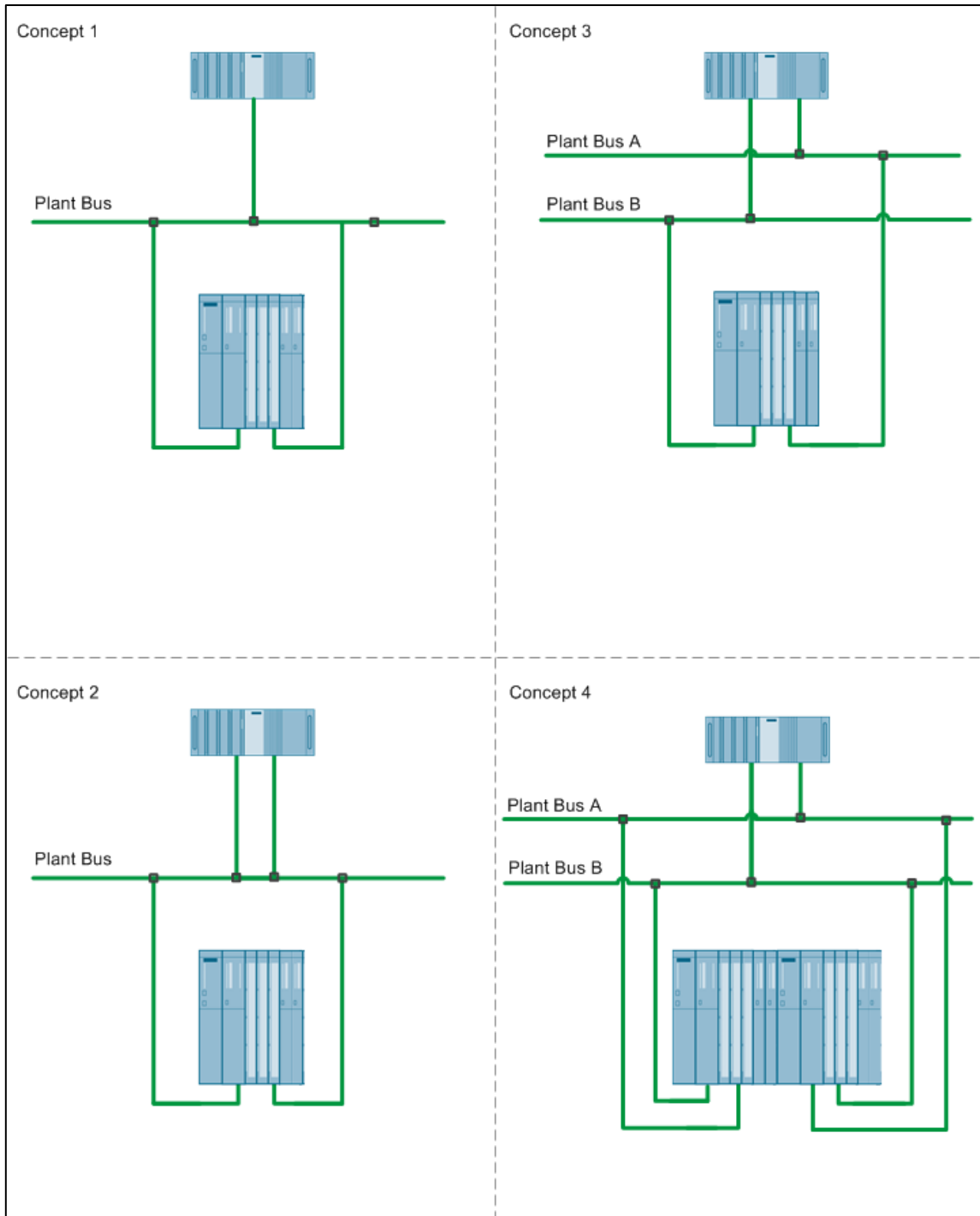

Copyright © Siemens AG 2013 All rights reserved

Bill of material for the redundant AS 410-5H automation system

- Concept 1

Table 15–8

Required	Optional	Product number	Product description	Note
Automation system				
1		6ES7 656-6CL30-1CF0	SIMATIC PCS 7 REDUNDANCY AS, 2X CPU 410-5H, 2 DP-MODULE, 2X PROFINET-IO, SYSTEM EXPANSION CARD 500 PO, AS RT PO 100, 2 X 2 10M SYNC-MODULE AND 2 X 1M FO, 1 X UR2-H ALU RACK, 2 X UC 120/230V 10A RED. POWER SUPPLY	³⁾
Engineering System and Operator System				
1		6GK1 716-0HB08-1AC0	SIMATIC NET, S7-REDCONNECT POWERPACK	¹⁾

- Concept 2, concept 3

Table 15–9

Required	Optional	Product number	Product description	Note
Automation system				
1		6ES7 656-6CL30-1CF0	SIMATIC PCS 7 REDUNDANCY AS, 2X CPU 410-5H, 2 DP-MODULE, 2X PROFINET-IO, SYSTEM EXPANSION CARD 500 PO, AS RT PO 100, 2 X 2 10M SYNC-MODULE AND 2 X 1M FO, 1 X UR2-H ALU RACK, 2 X UC 120/230V 10A RED. POWER SUPPLY	³⁾
Engineering System and Operator System				
1		6GK1 716-0HB08-1AC0	SIMATIC NET, S7-REDCONNECT POWERPACK	¹⁾
1		6GK1 162-3AA00	SIMATIC NET COMMUNICATION PROCESSOR CP 1623 PCI EXPRESS	¹⁾ ²⁾

- Concept 4

Table 15–10

Required	Optional	Product number	Product description	Note
Automation system				
1		6ES7656-6CL34-1CF0	SIMATIC PCS 7 REDUNDANCY AS, 2X CPU 410-5H, 2 DP-MODULE, 2X PROFINET-IO, 2x2 CP443-1IE, SYSTEM EXPANSION CARD 500 PO, AS RT PO 100, 2 X 2 10M SYNC-MODULE AND 2 X 1M FO, 1 X UR2-H ALU RACK, 2 X UC 120/230V 10A RED. POWER SUPPLY	
Engineering System and Operator System				
1		6GK1 716-0HB08-1AC0	SIMATIC NET, S7-REDCONNECT POWERPACK	1)
1		6GK1 162-3AA00	SIMATIC NET COMMUNICATION PROCESSOR CP 1623 PCI EXPRESS	1) 2)

Note

SCALANCE switch and network components must be added; see the description of the network topology in this chapter to select the appropriate configuration and components.

- 1) REDCONNECT upgrade and CP1623 are needed for every Operator System and Engineering System integrated in the system bus.
- 2) The bill of material is based on the assumption that the selected Operator System and Engineering System hardware is equipped with a CP1623 (industrial Ethernet version of the hardware); only additional CP1623 communications processors are listed.

15.8 Redundancy concept - terminal bus

15.8.1 Introduction

OS servers and clients as well as Engineering Systems, Batch servers, Route Control servers and Central Archive servers can be equipped with a redundant terminal bus connection. There are two redundancy functions to do this.

INTEL Teaming

The onboard network cards of the IPCs or the redundant terminal bus adapter package and the Intel network driver software combine the two existing physical network cards into one logical network card.

Only the logical network card having one IP and MAC address is visible to the operating system and the network. The combined network cards operate internally in master/slave operation. Only one card is actively involved in the communication. The second card is inactive and in standby mode.

Due to the failure detection properties of INTEL teaming, a (double) redundant network also requires a redundant connection of the two Ethernet rings.

SIMATIC NET IE RNA

Just like INTEL teaming, the physically existing network cards are also combined into one logical network card.

Only the logical network card having one IP and MAC address is visible to the operating system and the network. Both network cards operate internally using the PRP protocol (Parallel Redundancy Protocol).

The data packets are transmitted in parallel via both network cards. The first incoming message is processed on the receiver side. The parallel sent message is discarded. A (double) redundant network without connection between the Ethernet rings must be used due to the parallel data transmission. In the event of a fault, the parallel transfer is achieved with a 0ms delay.

- Concept 1, (only INTEL Teaming) single network
 - redundant terminal bus connection in every server and client
 - single fault-tolerant ring network
- Concept 2, ((only INTEL Teaming) (double) redundant network
 - redundant terminal bus connection in every server and client
 - (double) redundant fault-tolerant ring network with standby redundancy between the two rings
- Concept 3 (only SIMATIC NET IE RNA) (double) redundant network
 - redundant terminal bus connection in every server and client
 - (double) redundant fault-tolerant ring network

15.8.2 Redundant terminal bus

Figure 15-10

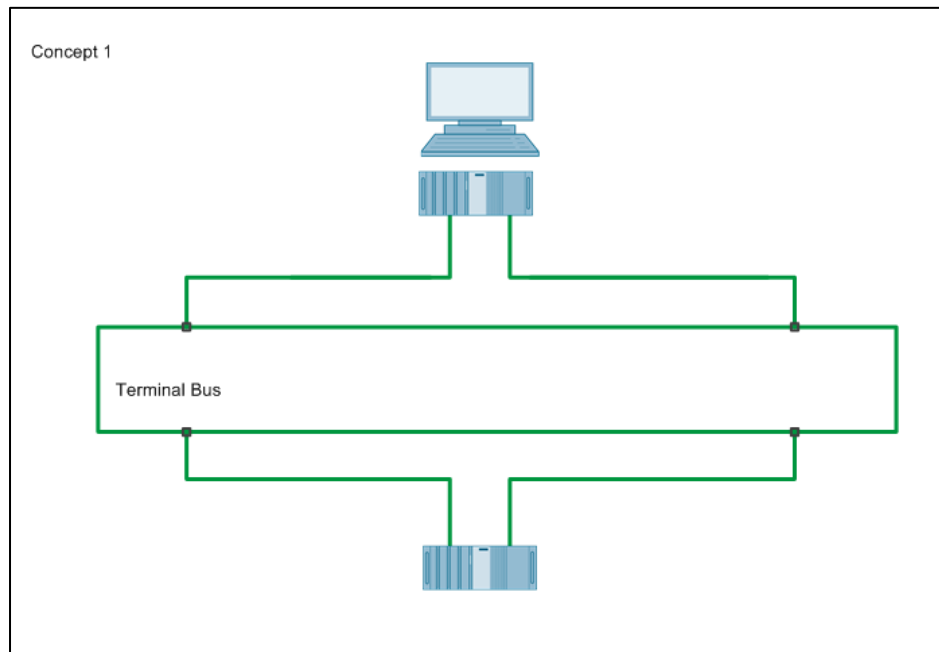

Figure 15-11

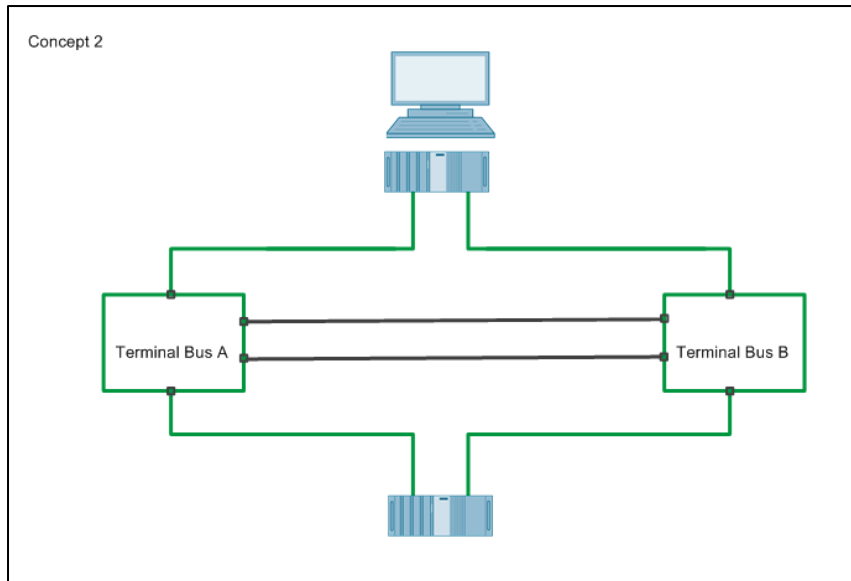
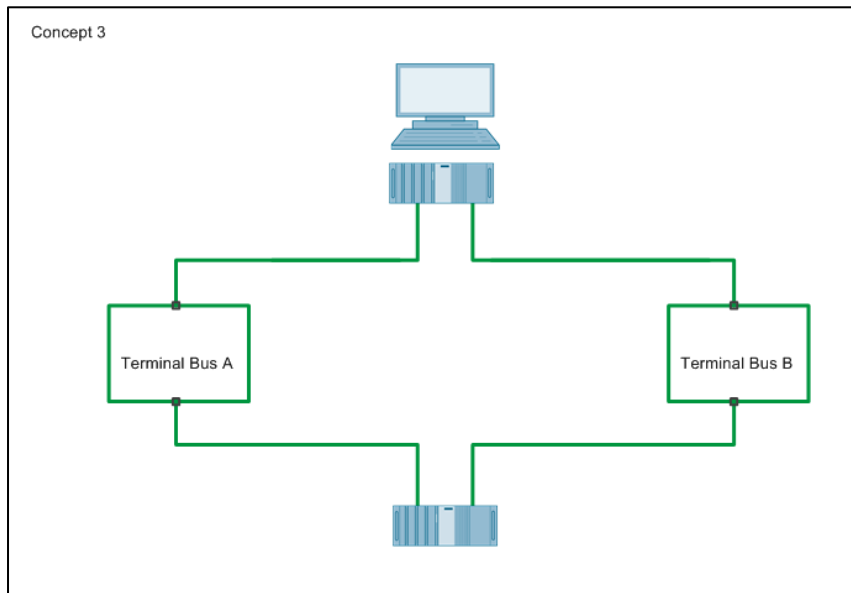

Figure 15-12



Bill of material for the redundant terminal bus with INTEL Teaming

Table 15–11

Required	Optional	Product number	Product description	Note
Operator System server				
1		6ES7 652-0XX01-1XF1	SIMATIC PCS 7 REDUNDANT TERMINAL BUS ADAPTER PACKAGE, 2 X INTEL PCI-E (EXPRESS) NETWORK CARD	1)
Operator System client				
1		6ES7 652-0XX01-1XF1	SIMATIC PCS 7 REDUNDANT TERMINAL BUS ADAPTER PACKAGE, 2 X INTEL PCI-E (EXPRESS) NETWORK CARD	2)

Bill of material for the redundant terminal bus with SIMATIC NET IE RNA

Table 15–12

Required	Optional	Product number	Product description	Note
Operator System server				
1		6GK1711-1EW08-2AA0	SIMATIC NET SOFTNET-IE RNA V8.2 REDUNDANT NETWORK ACCESS, NETZZUGANGSSOFTWARE FUER PRP NETZSTRUKTUREN	3) 4)
Operator System client				
1		6GK1711-1EW08-2AA0	SIMATIC NET SOFTNET-IE RNA V8.2 REDUNDANT NETWORK ACCESS, NETZZUGANGSSOFTWARE FUER PRP NETZSTRUKTUREN	3 4)

Note

SCALANCE switch and network components must be added; see the description of the network topology in this chapter to select the appropriate configuration and components.

- 1) Must be selected for every Batch server, Route Control server and Central Archive server as well as the Engineering System.
- 2) The two onboard Ethernet interfaces (INTEL) can be used for teaming with the IPC instead of the redundant terminal bus adapter package.
- 3) The onboard interfaces can be used
- 4) Single License for one installation

16 Safety Systems

Process safety for the single-user station

Safety Instrumented Systems are built on the proven SIMATIC PCS 7 Safety System technology. Like all other architectures in SIMATIC PCS 7, the architecture of Safety Systems is scalable from small to large systems and offers the complete functionality for each size. The SIMATIC PCS 7 Single-user Safety System includes functionality for engineering, operation and control of an entire Safety Instrumented System in a fail-safe automation system. The fail-safe Safety System is configured using CFC logic or the Safety Matrix. The Safety Matrix is a cause & effect engineering tool with the addition of a visualizing component. The Safety Matrix can be either used independently or as an integrated component of the Engineering System.

Client/server

Medium to large systems are implemented using standard systems and safety automation systems connected to an OS server. Engineering, operation and control functions are distributed over the Engineering and Operator System PC.

Redundant client/server

The high-availability of operation and control functionalities is achieved through redundant OS servers and high-availability automation systems.

16.1 Single-user station with Safety System

Figure 16-1

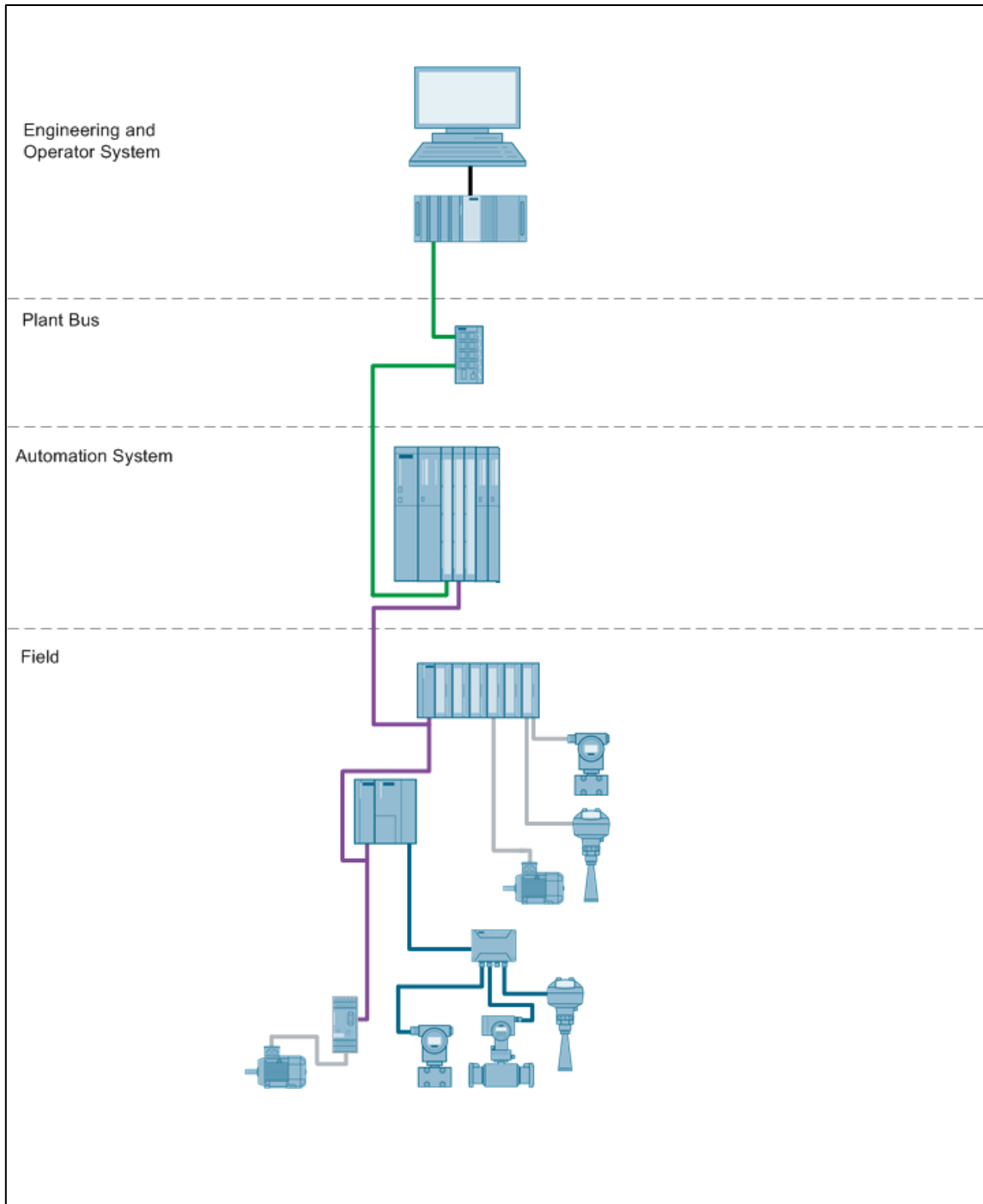

Bill of material for the single-user architecture with Safety System

Table 16–1

Required	Optional	Product number	Product description	Note
Engineering System and Operator System				
1		6ES7660-2AA30-1CA0	SIMATIC PCS 7 INDUSTRIAL WORKSTATION IPC847C, CORE I7, ES/OS SINGLESTATION, RAID1 (500GB INTERNAL), 8GB DDR3, BCE, PCS 7 V8.0 SP1, WIN 7	
1		6ES7 658-5AX08-0YA5	SOFTWARE SIMATIC PCS 7 AS/OS ENGINEERING V8.0	
1		6ES7 658-2AA08-0YA0	SOFTWARE SIMATIC PCS 7 OS SOFTWARE SINGLE STATION V8.0 (PO 100)	1)
1		6ES7 833-1CC02-0YA5	SOFTWARE SIMATIC S7, F-PROG-SW ENG	
	1	6ES7 833-1SM02-0YA5	SOFTWARE SIMATIC SAFETY MATRIX TOOL V6.2	
	1	6ES7 833-1SM62-0YA5	SOFTWARE SIMATIC SAFETY MATRIX VIEWER V6.2	
	1	6ES7 652-0XD08-2YB5	SOFTWARE SIMATIC PCS 7 SFC VISUALIZATION V8.0	
	1	6ES7 658-1CX17-2YA5	SOFTWARE SIMATIC PCS 7 VERSION CROSS MANAGER V7.1	
	1	6ES7 658-1FX08-2YA5	SOFTWARE SIMATIC PCS 7 VERSION TRAIL V8.0	
	1	6ES7 658-1DX08-2YB5	SOFTWARE SIMATIC PCS 7 IMPORT EXPORT ASSISTANT V8.0	
System bus				
1		6GK5 208-0BA10-2AA3	SIMATIC NET SCALANCE X208, MANAGED IE SWITCH, 8 X 10/100MBIT/S	2)
2		6XV1 870-3QH60	SIMATIC NET INDUSTRIAL ETHERNET TP CORD CABLE RJ45/RJ45, 6M	
Automation system				
1		6ES7654-6CC03-3BF0	SIMATIC PCS 7 SINGLE AS, CPU 410-5H, 1X DP-MODULE; 1X PROFINET-IO, SYSTEM EXPANSION CARD 500 INCL. F-RUNTIME LICENSE, AS RT PO 100, 1X CP443-1 IE/PN, UR2 ALU RACK, 1X UC 120/230V 10A POWER SUPPLY	1) 3)

Note

1) The number of POs can be increased later on by means of extra volume licenses.

2) SCALANCE switch requires a 24VDC power supply (not listed).

3) Please use the PCS 7 AS configurator, as the PCS 7 AS 410-5H is available in different versions, e.g. 24V DC or 110/230V AC.

16.2 Client/server with Safety System

Figure 16-2

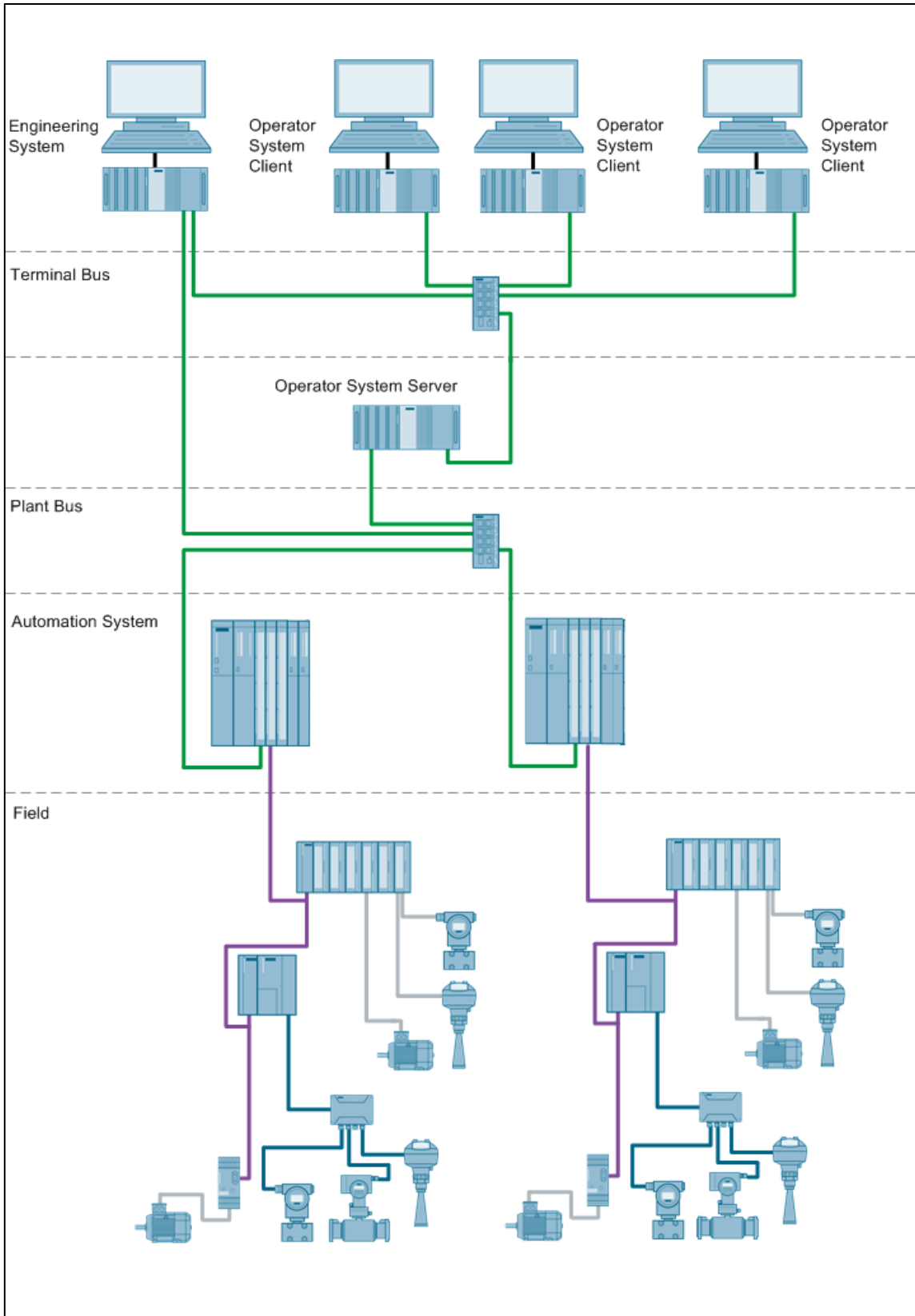

Bill of material for the client/server architecture with Safety System

Table 16–2

Required	Optional	Product number	Product description	Note
Engineering System				
1		6ES7660-2AA30-1CA0	SIMATIC PCS 7 INDUSTRIAL WORKSTATION IPC847C, CORE I7, ES/OS SINGLESTATION, RAID1 (500GB INTERNAL), 8GB DDR3, BCE, PCS 7 V8.0 SP1, WIN 7	
1		6ES7 658-5AX08-0YA5	SOFTWARE SIMATIC PCS 7 AS/OS ENGINEERING V8.0	
1		6ES7 833-1CC02-0YA5	SOFTWARE SIMATIC S7, F-PROG-SW ENG	
	1	6ES7 833-1SM02-0YA5	SOFTWARE SIMATIC SAFETY MATRIX TOOL V6.2	
	1	6ES7 833-1SM62-0YA5	SOFTWARE SIMATIC SAFETY MATRIX VIEWER V6.2	
	1	6ES7 658-1CX17-2YA5	SOFTWARE SIMATIC PCS 7 VERSION CROSS MANAGER V7.1	
	1	6ES7 658-1FX08-2YA5	SOFTWARE SIMATIC PCS 7 VERSION TRAIL V8.0	
	1	6ES7 658-1DX08-2YB5	SOFTWARE SIMATIC PCS 7 IMPORT EXPORT ASSISTANT V8.0	
Operator System server				
1		6ES7660-2BA30-1DA0	SIMATIC PCS 7 INDUSTRIAL WORKSTATION IPC847C, CORE I7, OS SERVER, RAID1 (500GB INTERNAL), 8GB DDR3, BCE, PCS 7 V8.0 SP1, WIN SERVER 2008	
1		6ES7 658-2BA08-0YA0	SOFTWARE SIMATIC PCS 7 OS SOFTWARE SERVER V8.0 (PO 100)	¹⁾
Operator System client				
3		6ES7660-1CA18-1CA0	SIMATIC PCS 7 INDUSTRIAL WORKSTATION IPC647C, CORE I7, OS CLIENT, 500GB INTERNAL, 4GB DDR3, PCS 7 V8.0 SP1, WIN 7	
3		6ES7 658-2CX08-0YB5	SOFTWARE SIMATIC PCS 7 OS CLIENT V8.0	
	3	6ES7 833-1SM62-0YA5	SOFTWARE SIMATIC SAFETY MATRIX VIEWER V6.2	
	3	6ES7 652-0XD08-2YB5	SOFTWARE SIMATIC PCS 7 SFC VISUALIZATION V8.0	

Required	Optional	Product number	Product description	Note
Terminal bus				
1		6GK5 208-0BA10-2AA3	SIMATIC NET SCALANCE X208, MANAGED IE SWITCH, 8 X 10/100MBIT/S	²⁾
5		6XV1 870-3QH60	SIMATIC NET INDUSTRIAL ETHERNET TP CORD CABLE RJ45/RJ45, 6M	
System bus				
1		6GK5 208-0BA10-2AA3	SIMATIC NET SCALANCE X208, MANAGED IE SWITCH, 8 X 10/100MBIT/S	²⁾
4		6XV1 870-3QH60	SIMATIC NET INDUSTRIAL ETHERNET TP CORD CABLE RJ45/RJ45, 6M	
Automation system				
2		6ES7654-6CE00-3BF0	SIMATIC PCS 7 SINGLE AS, CPU 410-5H, 1X DP-MODULE; 1X PROFINET-IO, SYSTEM EXPANSION CARD 1000 INCL. F-RUNTIME LICENSE, AS RT PO 100, UR2 ALU RACK, 1X UC 120/230V 10A POWER SUPPLY	³⁾

Note

- ¹⁾ The number of POs can be increased later on by means of extra volume licenses.
- ²⁾ SCALANCE switch requires a 24VDC power supply (not listed).
- ³⁾ Please use the PCS 7 AS configurator, as the PCS 7 AS 410-5H is available in different versions, e.g. 24V DC or 110/230V AC.

16.3 Client/server with redundant Safety System

Figure 16-3

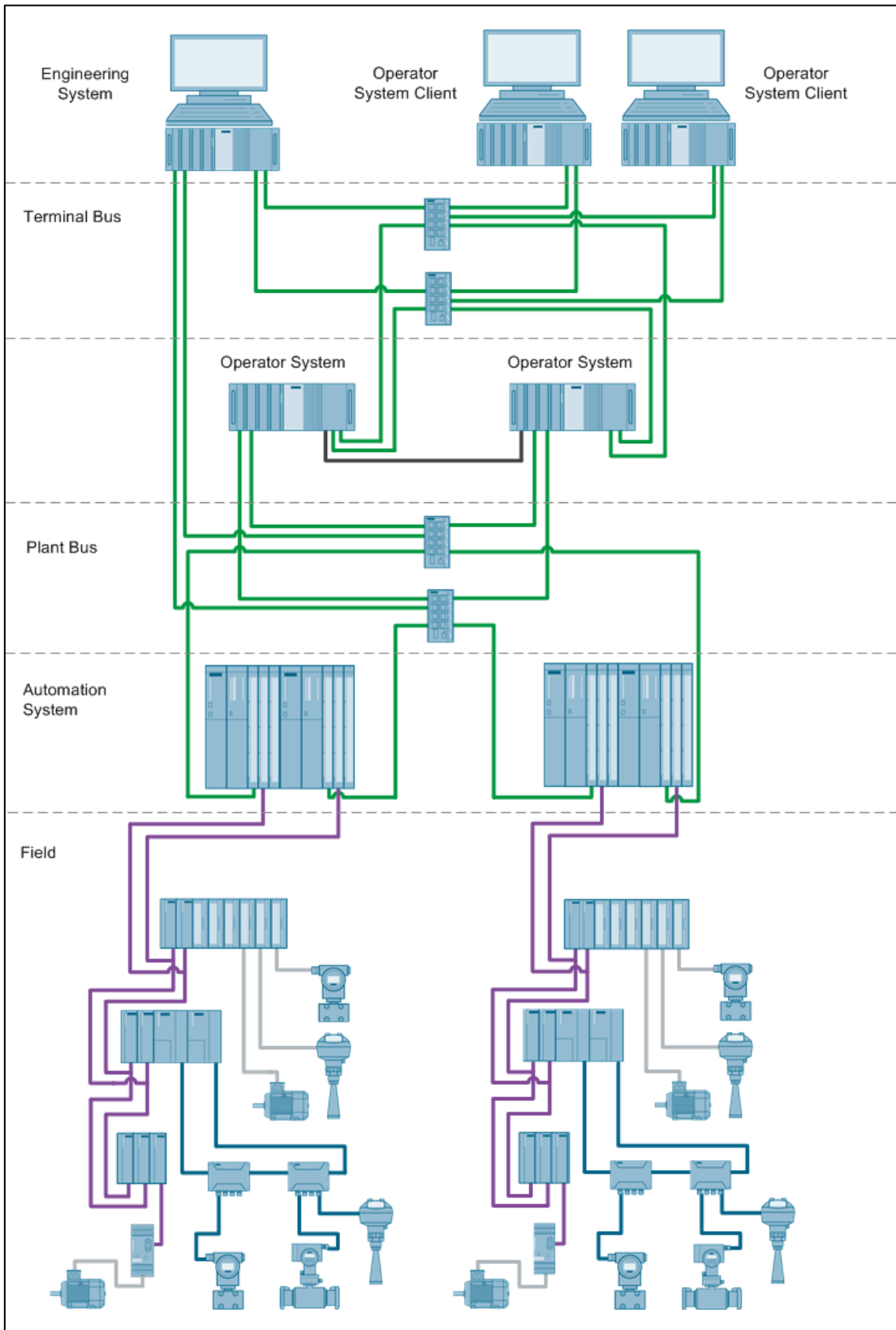

Copyright © Siemens AG 2013 All rights reserved

Bill of material for the client/server architecture with redundant Safety System

Table 16–3

Required	Optional	Product number	Product description	Note
Engineering System				
1		6ES7 660-2AA31-1CA0	SIMATIC PCS 7 INDUSTRIAL WORKSTATION IPC847C, CORE I7, ES/OS SINGLESTATION, RAID1 (500GB FRONT MOUNTED), 8GB DDR3, INDUSTRIAL ETHERNET (CP1623), PCS 7 V8.0 SP1, WIN 7	
1		6ES7 658-5AX08-0YA5	SOFTWARE SIMATIC PCS 7 AS/OS ENGINEERING V8.0	
1		6ES7 833-1CC02-0YA5	SOFTWARE SIMATIC S7, F-PROG-SW ENG	
	1	6ES7 833-1SM02-0YA5	SOFTWARE SIMATIC SAFETY MATRIX TOOL V6.2	
	1	6ES7 833-1SM62-0YA5	SOFTWARE SIMATIC SAFETY MATRIX VIEWER V6.2	
1		6GK1 162-3AA00	SIMATIC NET COMMUNICATION PROCESSOR CP 1623 PCI EXPRESS	1)
1		6GK1 716-0HB08-1AC0	SIMATIC NET, S7-REDCONNECT POWERPACK	4)
1		6ES7 652-0XX01-1XF1	SIMATIC PCS 7 REDUNDANT TERMINAL BUS ADAPTER PACKAGE, 2 X INTEL PCI-E (EXPRESS) NETWORK CARD	2)
	1	6ES7 658-1CX17-2YA5	SOFTWARE SIMATIC PCS 7 VERSION CROSS MANAGER V7.1	
	1	6ES7 658-1FX08-2YA5	SOFTWARE SIMATIC PCS 7 VERSION TRAIL V8.0	
	1	6ES7 658-1DX08-2YB5	SOFTWARE SIMATIC PCS 7 IMPORT EXPORT ASSISTANT V8.0	
Operator System server				
2		6ES7660-2BB31-1DA0	SIMATIC PCS 7 INDUSTRIAL WORKSTATION IPC847C, CORE I7, OS SERVER, RAID1 (500GB FRONT MOUNTED), 8GB DDR3, INDUSTRIAL ETHERNET (CP1623), PCS 7 V8.0 SP1, WIN SERVER 2008	
1		6ES7 652-3BA08-2YA0	SOFTWARE SIMATIC PCS 7 OS SERVER REDUNDANCY V8.0 (PO 100)	3) 7)
2		6GK1 162-3AA00	SIMATIC NET COMMUNICATION PROCESSOR CP 1623 PCI EXPRESS	1)
2		6GK1 716-0HB08-1AC0	SIMATIC NET, S7-REDCONNECT POWERPACK	4)
2		6ES7 652-0XX01-1XF1	SIMATIC PCS 7 REDUNDANT TERMINAL BUS ADAPTER PACKAGE, 2 X INTEL PCI-E (EXPRESS) NETWORK CARD	2)

Required	Optional	Product number	Product description	Note
Operator System client				
2		6ES7660-1CA18-1CA0	SIMATIC PCS 7 INDUSTRIAL WORKSTATION IPC647C, CORE I7, OS CLIENT, 500GB INTERNAL, 4GB DDR3, PCS 7 V8.0 SP1, WIN 7	
2		6ES7 652-0XX01-1XF1	SIMATIC PCS 7 REDUNDANT TERMINAL BUS ADAPTER PACKAGE, 2 X INTEL PCI-E (EXPRESS) NETWORK CARD	2)
2		6ES7 658-2CX08-0YB5	SOFTWARE SIMATIC PCS 7 OS CLIENT V8.0	
	2	6ES7 833-1SM62-0YA5	SOFTWARE SIMATIC SAFETY MATRIX VIEWER V6.2	
	2	6ES7 652-0XD08-2YB5	SOFTWARE SIMATIC PCS 7 SFC VISUALIZATION V8.0	
Terminal bus				
2		6GK5 208-0BA10-2AA3	SIMATIC NET SCALANCE X208, MANAGED IE SWITCH, 8 X 10/100MBIT/S	5)
10		6XV1 870-3QH60	SIMATIC NET INDUSTRIAL ETHERNET TP CORD CABLE RJ45/RJ45, 6M	
System bus				
2		6GK5 208-0BA10-2AA3	SIMATIC NET SCALANCE X208, MANAGED IE SWITCH, 8 X 10/100MBIT/S	5)
10		6XV1 870-3QH60	SIMATIC NET INDUSTRIAL ETHERNET TP CORD CABLE RJ45/RJ45, 6M	
Automation system				
2		6ES7656-6CE30-1BF0	SIMATIC PCS 7 REDUNDANCY AS, 2X CPU 410-5H, 2 DP-MODULE, 2X PROFINET-IO, SYSTEM EXPANSION CARD 1000 PO INCL. F-RUNTIME LICENSE, AS RT PO 100, 2 X 2 10M SYNC-MODULE AND 2 X 1M FO, 1 X UR2-H ALU RACK, 2 X UC 120/230V 10A RED. POWER SUPPLY SIMATIC	6)

Note

- 1) Required in case a redundant system bus is chosen.
- 2) Required in case a redundant terminal bus is chosen.
- 3) The number of POs can be increased later on by means of extra volume licenses.
- 4) Required in case a redundant system bus or a redundant automation system is chosen.
- 5) SCALANCE switch requires a 24VDC power supply (not listed).
- 6) Please use the PCS 7 AS configurator, as the PCS 7 AS 410-5H is available in different versions, e.g. 24V DC or 110/230V AC.
- 7) The redundant OS server is supplied with an RS-232 serial connection cable. If there is a long distance between the redundant systems, one can use an Ethernet connection as an alternative. This requires additional Ethernet network interface cards in the systems.

17 Possibilities for data exchange

Client/server system and OpenPCS 7

SIMATIC PCS 7 offers anytime access to all real-time values, archive values and messages. The OpenPCS 7 software is the extensive interface for this access. This establishes the connection to the SIMATIC PCS 7 OS servers as well as to the Central Archive servers and offers access to all data via standard OPC server technology. It combines OPC DA (Data Access), OPC HDA (Historical Data Access), OPC AE (Alarms & Events) and OPC HAE (Historical Alarms & Events) in one system.

In addition to this, it is also possible to achieve simple, standardized direct access to the archive data in the Microsoft SQL server database of the Operator System via OLE-DB.

Small system

Smaller systems benefit from a cost-effective combination of functionality from OpenPCS 7 and OS clients.

Large system

With regard to high-performance and large applications, OpenPCS 7 runs on a standalone PC and provides access to all data located on multiple redundant SIMATIC PCS 7 systems composed of OS servers and Process Historians.

17.1 Client/server system and OpenPCS 7

Figure 17-1

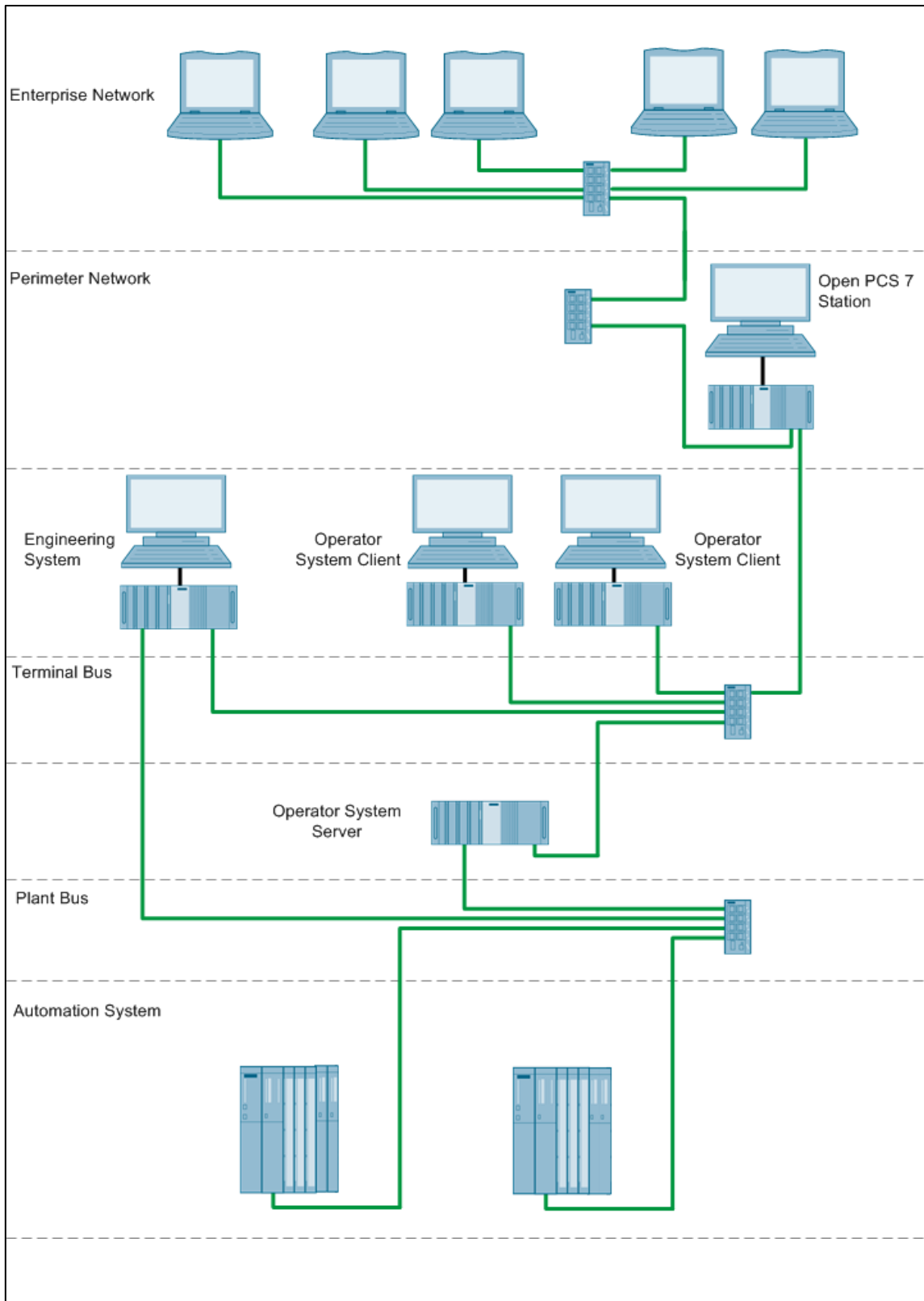

Copyright © Siemens AG 2013 All rights reserved

Bill of material for the client/server system and OpenPCS 7

Table 17-1

Required	Optional	Product number	Product description	Note
Engineering System				
1		6ES7660-2AA30-1CA0	SIMATIC PCS 7 INDUSTRIAL WORKSTATION IPC847C, CORE I7, ES/OS SINGLESTATION, RAID1 (500GB INTERNAL), 8GB DDR3, BCE, PCS 7 V8.0 SP1, WIN 7	
1		6ES7 658-5AX08-0YA5	SOFTWARE SIMATIC PCS 7 AS/OS ENGINEERING V8.0	
	1	6ES7 658-1CX17-2YA5	SOFTWARE SIMATIC PCS 7 VERSION CROSS MANAGER V7.1	
	1	6ES7 658-1FX08-2YA5	SOFTWARE SIMATIC PCS 7 VERSION TRAIL V8.0	
	1	6ES7 658-1DX08-2YB5	SOFTWARE SIMATIC PCS 7 IMPORT EXPORT ASSISTANT V8.0	
Operator System server				
1		6ES7660-2BA30-1DA0	SIMATIC PCS 7 INDUSTRIAL WORKSTATION IPC847C, CORE I7, OS SERVER, RAID1 (500GB INTERNAL), 8GB DDR3, BCE, PCS 7 V8.0 SP1, WIN SERVER 2008	
1		6ES7 658-2BA08-0YA0	SOFTWARE SIMATIC PCS 7 OS SOFTWARE SERVER V8.0 (PO 100)	¹⁾
Operator System client				
2		6ES7660-1CA18-1CA0	SIMATIC PCS 7 INDUSTRIAL WORKSTATION IPC647C, CORE I7, OS CLIENT, 500GB INTERNAL, 4GB DDR3, PCS 7 V8.0 SP1, WIN 7	
2		6ES7 658-2CX08-0YB5	SOFTWARE SIMATIC PCS 7 OS CLIENT V8.0	
	2	6ES7 652-0XD08-2YB5	SOFTWARE SIMATIC PCS 7 SFC VISUALIZATION V8.0	
Open PCS 7 station				
1		6ES7660-1CA18-1CA0	SIMATIC PCS 7 INDUSTRIAL WORKSTATION IPC647C, CORE I7, OS CLIENT, 500GB INTERNAL, 4GB DDR3, PCS 7 V8.0 SP1, WIN 7	
1		A5E02639550	DESKTOP ADAPTER NETWORK CARD	⁴⁾
1		6ES7 658-0HX08-2YB0	SOFTWARE SIMATIC PCS 7 OPENPCS 7 V8.0	

Required	Optional	Product number	Product description	Note
Terminal bus				
1		6GK5 208-0BA10-2AA3	SIMATIC NET SCALANCE X208, MANAGED IE SWITCH, 8 X 10/100MBIT/S	²⁾
5		6XV1 870-3QH60	SIMATIC NET INDUSTRIAL ETHERNET TP CORD CABLE RJ45/RJ45, 6M	
System bus				
1		6GK5 208-0BA10-2AA3	SIMATIC NET SCALANCE X208, MANAGED IE SWITCH, 8 X 10/100MBIT/S	²⁾
4		6XV1 870-3QH60	SIMATIC NET INDUSTRIAL ETHERNET TP CORD CABLE RJ45/RJ45, 6M	
Automation system				
2		6ES7654-6CP03-3BF0	SIMATIC PCS 7 SINGLE AS, CPU 410-5H, 1X DP-MODULE, 1x PROFINET-IO, SYSTEM EXPANSIONS CARD 1600 PO, AS RT PO 100, CP443-1IE, UR2 ALU RACK, 1 X UC 120/230V 10A POWER SUPPLY SIMATIC	³⁾

Note

Enterprise network switch and cable are not listed.

¹⁾ The number of POs can be increased later on by means of extra volume licenses.

²⁾ SCALANCE switch requires a 24VDC power supply (not listed).

³⁾ Please use the PCS 7 AS configurator, as the PCS 7 AS 410-5H is available in different versions, e.g. 24V DC or 110/230V AC.

⁴⁾ Enterprise network connection

Firewall applications between the terminal bus and perimeter network, and between the perimeter network and enterprise network are not listed but necessary.

Network components for perimeter network and enterprise network connection have not been listed.

17.2 Small client/server system and OpenPCS 7

Figure 17-2

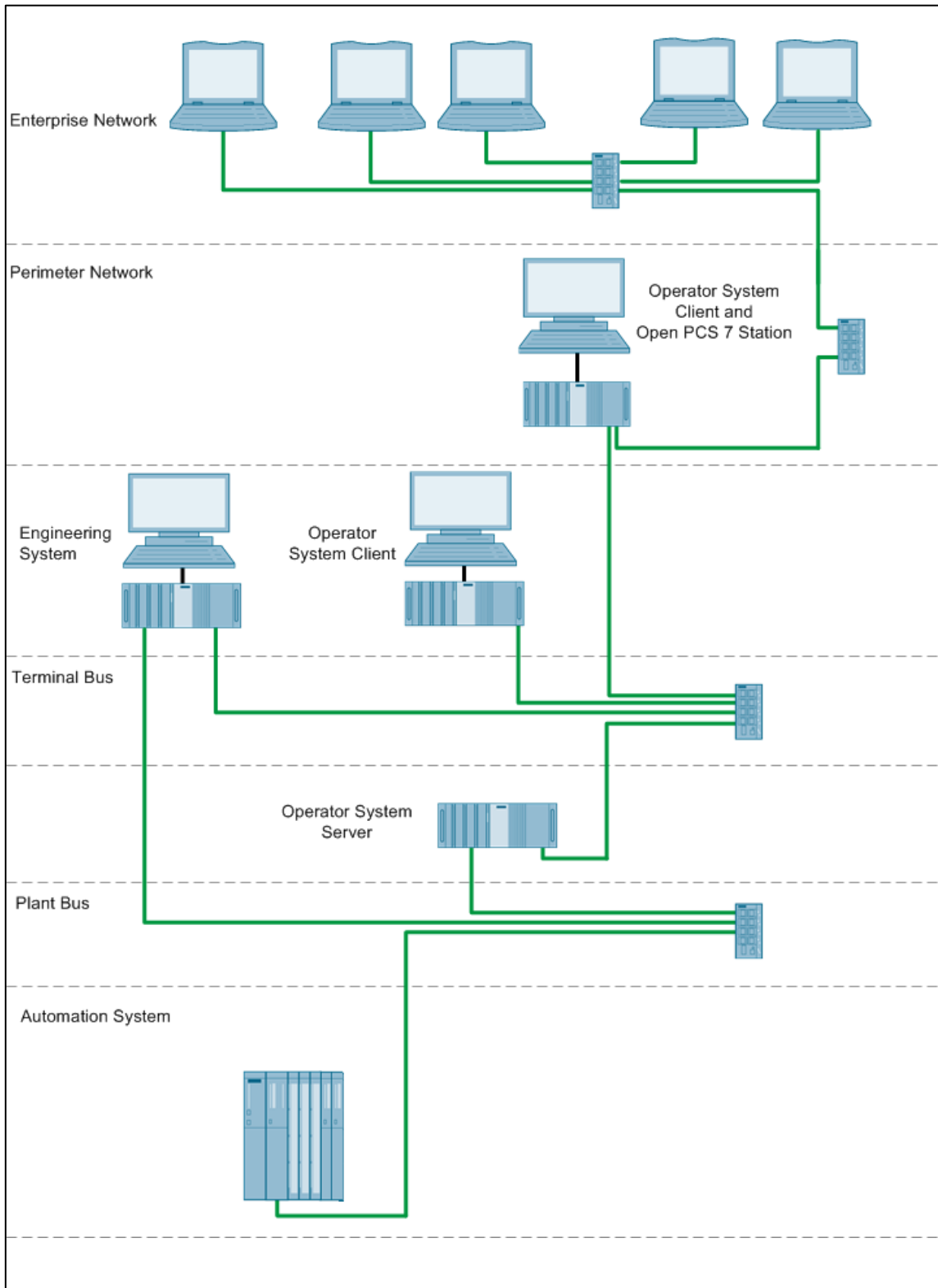

Bill of material for a small client/server system and OpenPCS 7

Table 17-2

Required	Optional	Product number	Product description	Note
Engineering System				
1		6ES7660-2AA30-1CA0	SIMATIC PCS 7 INDUSTRIAL WORKSTATION IPC847C, CORE I7, ES/OS SINGLESTATION, RAID1 (500GB INTERNAL), 8GB DDR3, BCE, PCS 7 V8.0 SP1, WIN 7	
1		6ES7 658-5AX08-0YA5	SOFTWARE SIMATIC PCS 7 AS/OS ENGINEERING V8.0	
	1	6ES7 658-1CX17-2YA5	SOFTWARE SIMATIC PCS 7 VERSION CROSS MANAGER V7.1	
	1	6ES7 658-1FX08-2YA5	SOFTWARE SIMATIC PCS 7 VERSION TRAIL V8.0	
	1	6ES7 658-1DX08-2YB5	SOFTWARE SIMATIC PCS 7 IMPORT EXPORT ASSISTANT V8.0	
Operator System server				
1		6ES7660-2BA30-1DA0	SIMATIC PCS 7 INDUSTRIAL WORKSTATION IPC847C, CORE I7, OS SERVER, RAID1 (500GB INTERNAL), 8GB DDR3, BCE, PCS 7 V8.0 SP1, WIN SERVER 2008	
1		6ES7 658-2BA08-0YA0	SOFTWARE SIMATIC PCS 7 OS SOFTWARE SERVER V8.0 (PO 100)	¹⁾
Operator System client				
1		6ES7660-1CA18-1CA0	SIMATIC PCS 7 INDUSTRIAL WORKSTATION IPC647C, CORE I7, OS CLIENT, 500GB INTERNAL, 4GB DDR3, PCS 7 V8.0 SP1, WIN 7	
1		6ES7 658-2CX08-0YB5	SOFTWARE SIMATIC PCS 7 OS CLIENT V8.0	
	1	6ES7 652-0XD08-2YB5	SOFTWARE SIMATIC PCS 7 SFC VISUALIZATION V8.0	
Operator System client and Open PCS 7 station				
1		6ES7660-1CA18-1CA0	SIMATIC PCS 7 INDUSTRIAL WORKSTATION IPC647C, CORE I7, OS CLIENT, 500GB INTERNAL, 4GB DDR3, PCS 7 V8.0 SP1, WIN 7	
1		A5E02639550	DESKTOP ADAPTER NETWORK CARD	⁴⁾
1		6ES7 658-2CX08-0YB5	SOFTWARE SIMATIC PCS 7 OS CLIENT V8.0	
1		6ES7 658-0GX08-2YB0	SOFTWARE SIMATIC PCS 7 OPENPCS 7 V8.0 (OS CLIENT)	
	1	6ES7 652-0XD08-2YB5	SOFTWARE SIMATIC PCS 7 SFC VISUALIZATION V8.0	

Required	Optional	Product number	Product description	Note
Terminal bus				
1		6GK5 208-0BA10-2AA3	SIMATIC NET SCALANCE X208, MANAGED IE SWITCH, 8 X 10/100MBIT/S	²⁾
4		6XV1 870-3QH60	SIMATIC NET INDUSTRIAL ETHERNET TP CORD CABLE RJ45/RJ45, 6M	
System bus				
1		6GK5 208-0BA10-2AA3	SIMATIC NET SCALANCE X208, MANAGED IE SWITCH, 8 X 10/100MBIT/S	²⁾
3		6XV1 870-3QH60	SIMATIC NET INDUSTRIAL ETHERNET TP CORD CABLE RJ45/RJ45, 6M	
Automation system				
1		6ES7654-6CN03-3BF0	SIMATIC PCS 7 SINGLE AS, CPU 410-5H, 1X DP-MODULE, 1x PROFINET-IO, SYSTEM EXPANSIONS CARD 1000 PO, AS RT PO 100, CP443-1IE, UR2 ALU RACK, 1 X UC 120/230V 10A POWER SUPPLY SIMATIC	³⁾

Note

- ¹⁾ The number of POs can be increased later on by means of extra volume licenses.
- ²⁾ SCALANCE switch requires a 24VDC power supply (not listed).
- ³⁾ Please use the PCS 7 AS configurator, as the PCS 7 AS 410-5H is available in different versions, e.g. 24V DC or 110/230V AC.
- ⁴⁾ Enterprise network connection
- Firewall applications between the terminal bus and perimeter network, and between the perimeter network and enterprise network are not listed but necessary.
- Network components for perimeter network and enterprise network connection have not been listed.

17.3 Large client/server system and OpenPCS 7

Figure 17-3

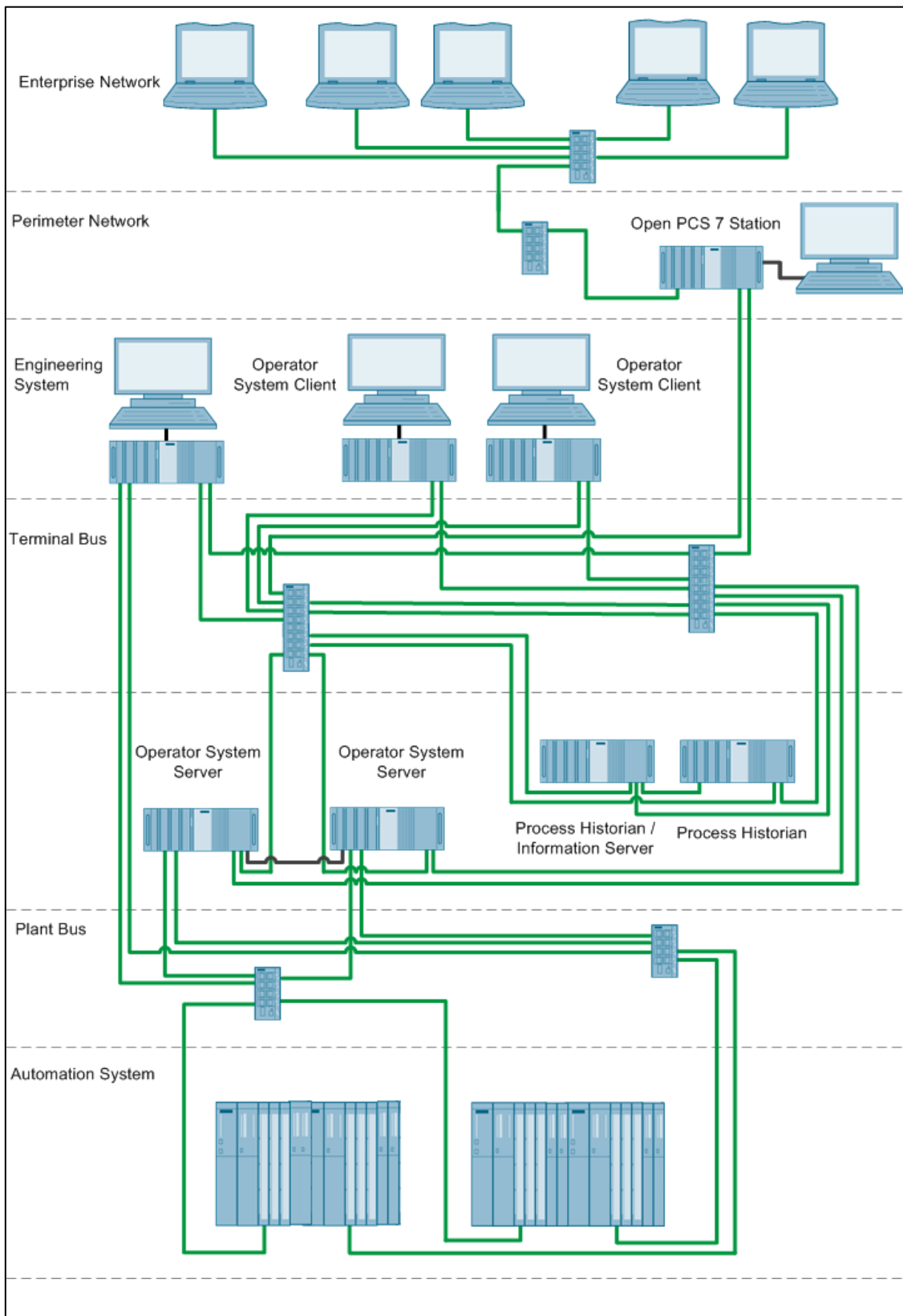

Copyright © Siemens AG 2013 All rights reserved

Bill of material for a large client/server system and OpenPCS 7

Table 17–3

Required	Optional	Product number	Product description	Note
Engineering System				
1		6ES7 660-2AA31-1CA0	SIMATIC PCS 7 INDUSTRIAL WORKSTATION IPC847C, CORE I7, ES/OS SINGLESTATION, RAID1 (500GB FRONT MOUNTED), 8GB DDR3, INDUSTRIAL ETHERNET (CP1623), PCS 7 V8.0 SP1, WIN 7	
1		6ES7 658-5AX08-0YA5	SOFTWARE SIMATIC PCS 7 AS/OS ENGINEERING V8.0	
1		6GK1 162-3AA00	SIMATIC NET COMMUNICATION PROCESSOR CP 1623 PCI EXPRESS	1)
1		6GK1 716-0HB08-1AC0	SIMATIC NET, S7-REDCONNECT POWERPACK	4)
1		6ES7 652-0XX01-1XF1	SIMATIC PCS 7 REDUNDANT TERMINAL BUS ADAPTER PACKAGE, 2 X INTEL PCI-E (EXPRESS) NETWORK CARD	2)
1		6ES7 658-1CX17-2YA5	SOFTWARE SIMATIC PCS 7 VERSION CROSS MANAGER V7.1	
1		6ES7 658-1FX08-2YA5	SOFTWARE SIMATIC PCS 7 VERSION TRAIL V8.0	
1		6ES7 658-1DX08-2YB5	SOFTWARE SIMATIC PCS 7 IMPORT EXPORT ASSISTANT V8.0	
Operator System server				
2		6ES7660-2BB31-1DA0	SIMATIC PCS 7 INDUSTRIAL WORKSTATION IPC847C, CORE I7, OS SERVER, RAID1 (500GB FRONT MOUNTED), 8GB DDR3, INDUSTRIAL ETHERNET (CP1623), PCS 7 V8.0 SP1, WIN SERVER 2008	
1		6ES7 652-3BA08-2YA0	SOFTWARE SIMATIC PCS 7 OS SERVER REDUNDANCY V8.0 (PO 100)	3) 9)
2		6GK1 162-3AA00	SIMATIC NET COMMUNICATION PROCESSOR CP 1623 PCI EXPRESS	1)
2		6GK1 716-0HB08-1AC0	SIMATIC NET, S7-REDCONNECT POWERPACK	4)
2		6ES7 652-0XX01-1XF1	SIMATIC PCS 7 REDUNDANT TERMINAL BUS ADAPTER PACKAGE, 2 X INTEL PCI-E (EXPRESS) NETWORK CARD	3)
Process Historian				
2		6ES7660-2BH38-1DA0	SIMATIC PCS 7 INDUSTRIAL WORKSTATION IPC847C, CORE I7, OS SERVER, RAID5 (3 X 1 TB, HDD SAS FRONT MOUNTED + SSD 100 GB SLC INTERN), 8GB DDR3, PCS 7 V8.0 SP1, WIN SERVER 2008	
2		A5E02639550	DESKTOP ADAPTER NETWORK CARD	8)
1		6XV1 870-3RH60	SIMATIC NET INDUSTRIAL ETHERNET TP XP CORD RJ45/RJ45, 6M	
1		6ES7652-7CX08-2YB0	SOFTWARE SIMATIC PCS 7 PROCESS HISTORIAN SERVER REDUNDANCY V8.0	7)
2		6ES7 652-0XX01-1XF1	SIMATIC PCS 7 REDUNDANT TERMINAL BUS	2)

17 Possibilities for data exchange

Required	Optional	Product number	Product description	Note
			ADAPTER PACKAGE, 2 X INTEL PCI-E (EXPRESS) NETWORK CARD	
Operator System client				
2		6ES7660-1CA18-1CA0	SIMATIC PCS 7 INDUSTRIAL WORKSTATION IPC647C, CORE I7, OS CLIENT, 500GB INTERNAL, 4GB DDR3, PCS 7 V8.0 SP1, WIN 7	
2		6ES7 652-0XX01-1XF1	SIMATIC PCS 7 REDUNDANT TERMINAL BUS ADAPTER PACKAGE, 2 X INTEL PCI-E (EXPRESS) NETWORK CARD	2)
2		6ES7 658-2CX08-0YB5	SOFTWARE SIMATIC PCS 7 OS CLIENT V8.0	
	2	6ES7 652-0XD08-2YB5	SOFTWARE SIMATIC PCS 7 SFC VISUALIZATION V8.0	
Open PCS 7 station				
1		6ES7660-1CA18-1CA0	SIMATIC PCS 7 INDUSTRIAL WORKSTATION IPC647C, CORE I7, OS CLIENT, 500GB INTERNAL, 4GB DDR3, PCS 7 V8.0 SP1, WIN 7	
1		6ES7 652-0XX01-1XF1	SIMATIC PCS 7 REDUNDANT TERMINAL BUS ADAPTER PACKAGE, 2 X INTEL PCI-E (EXPRESS) NETWORK CARD	2)
1		A5E02639550	DESKTOP ADAPTER NETWORK CARD	8)
1		6ES7 658-0HX08-2YB0	SOFTWARE SIMATIC PCS 7 OPENPCS 7 V8.0	
Terminal bus				
2		6GK5 216-0BA00-2AA3	SIMATIC NET SCALANCE X216, MANAGED IE SWITCH, 16 X 10/100MBIT/S	5)
18		6XV1 870-3QH60	SIMATIC NET INDUSTRIAL ETHERNET TP CORD CABLE RJ45/RJ45, 6M	
System bus				
2		6GK5 208-0BA10-2AA3	SIMATIC NET SCALANCE X208, MANAGED IE SWITCH, 8 X 10/100MBIT/S	5)
10		6XV1 870-3QH60	SIMATIC NET INDUSTRIAL ETHERNET TP CORD CABLE RJ45/RJ45, 6M	
Automation system				
2		6ES7 656-6CP33-1CF0	SIMATIC PCS 7 REDUNDANCY AS, 2X CPU 410-5H, 2 DP-MODULE, 2X PROFINET-IO, SYSTEM EXPANSION CARD 1600, AS RT PO 100, 2 X 2 10M SYNC-MODULE AND 2 X 1M FO, 2 X CP443-1 IE/PN, 1 X UR2-H ALU RACK, 2 X UC 120/230V 10A RED. POWER SUPPLY	6)

Note

- 1) Required in case a redundant system bus is chosen.
 - 2) Required in case a redundant terminal bus is chosen.
 - 3) The number of POs can be increased later on by means of extra volume licenses.
 - 4) Required in case a redundant system bus or a redundant automation system is chosen.
 - 5) SCALANCE switch requires a 24VDC power supply (not listed).
 - 6) Please use the PCS 7 AS configurator, as the PCS 7 AS 410-5H is available in different versions, e.g. 24V DC or 110/230V AC.
 - 7) The tag inventory can be expanded using cumulative volume licenses (SIMATIC PCS 7 OS/PH Archive up to a maximum of 120 000 archive tags).
 - 8) Enterprise network connection
 - 9) The redundant OS server is supplied with an RS-232 serial connection cable. If there is a long distance between the redundant systems, one can use an Ethernet connection as an alternative. This requires additional Ethernet network interface cards in the systems.
- Firewall applications between the terminal bus and perimeter network, and between the perimeter network and enterprise network are not listed but necessary.
- Network components for perimeter network and enterprise network connection have not been listed.

18 AS-OS PO Count

Starter System 250 PO

The following applies for the licensing of process objects "PO" in SIMATIC PCS 7 V 8.0:

These are counted as process objects by PCS 7:

- all SFCs
- all block instances that fulfill the following:
 - they can be operated and monitored
 - they generate messages
 - they are not channel blocks

These objects are transferred to the OS and require a license.

Block that can be operated and monitored have the attribute "S7_m_c = true" in their block properties.

Process objects may include the following blocks and objects:

- Blocks for operator control and monitoring of a plant
- Objects for automation
- Objects for signal capture and processing

As a general rule, 0.75...1.5 I/O corresponds to a process object.

For PCS 7 licensing, the total amount of process objects is counted regardless of the number of inputs and outputs. The data exchanged with other automation systems has also no effect on the number of process objects.

Note

The described PO count may vary for individual blocks. For example, the Model Predictive Controller (MPC) controller block is counted with 100 POs.

Single-user station 1000 PO

The bundled run-time license for the Operator and Automation System is intended for the Starter System and the Single-user System, supporting up to 2000 process objects with the Starter System and 5000 process objects with the Single-user System.

The SIMATIC PCS 7 AS Runtime license for 100 POs, that is already integrated in each AS bundle, can be expanded by means of cumulative runtime licenses.

Client/server from 2000 PO

With regard to engineering and test operation, SIMATIC PCS 7 offers a license for the AS Engineering and a license for the AS/OS Engineering, each with an unlimited number of process objects.

A SIMATIC PCS 7 server license with 100 OS runtime process objects is available for the OS server. The number of OS process objects can be increased by means of cumulative SIMATIC PCS 7 OS runtime licenses. OS clients require no licensing for process objects and can access all process objects on the connected OS server.

Redundant client/server 3000 PO

Redundant OS servers must be licensed with the appropriate number of process objects for both servers.

Multi-server 5000 PO

Systems consisting of several OS servers allow the distribution of the process objects on multiple servers. When multiple Engineering Systems are used, the process objects of the automation system must be licensed only once.

Note

In the following link you can find an FAQ on how to count POs:
<http://support.automation.siemens.com/WW/view/en/38855207>

You can find more information about licenses and quantity structures in the manual "SIMATIC Process Control System PCS 7 Licenses and quantity structures (V8.0)" with the item ID 58531455.

18.1 Starter System with 250 process objects

Figure 18-1

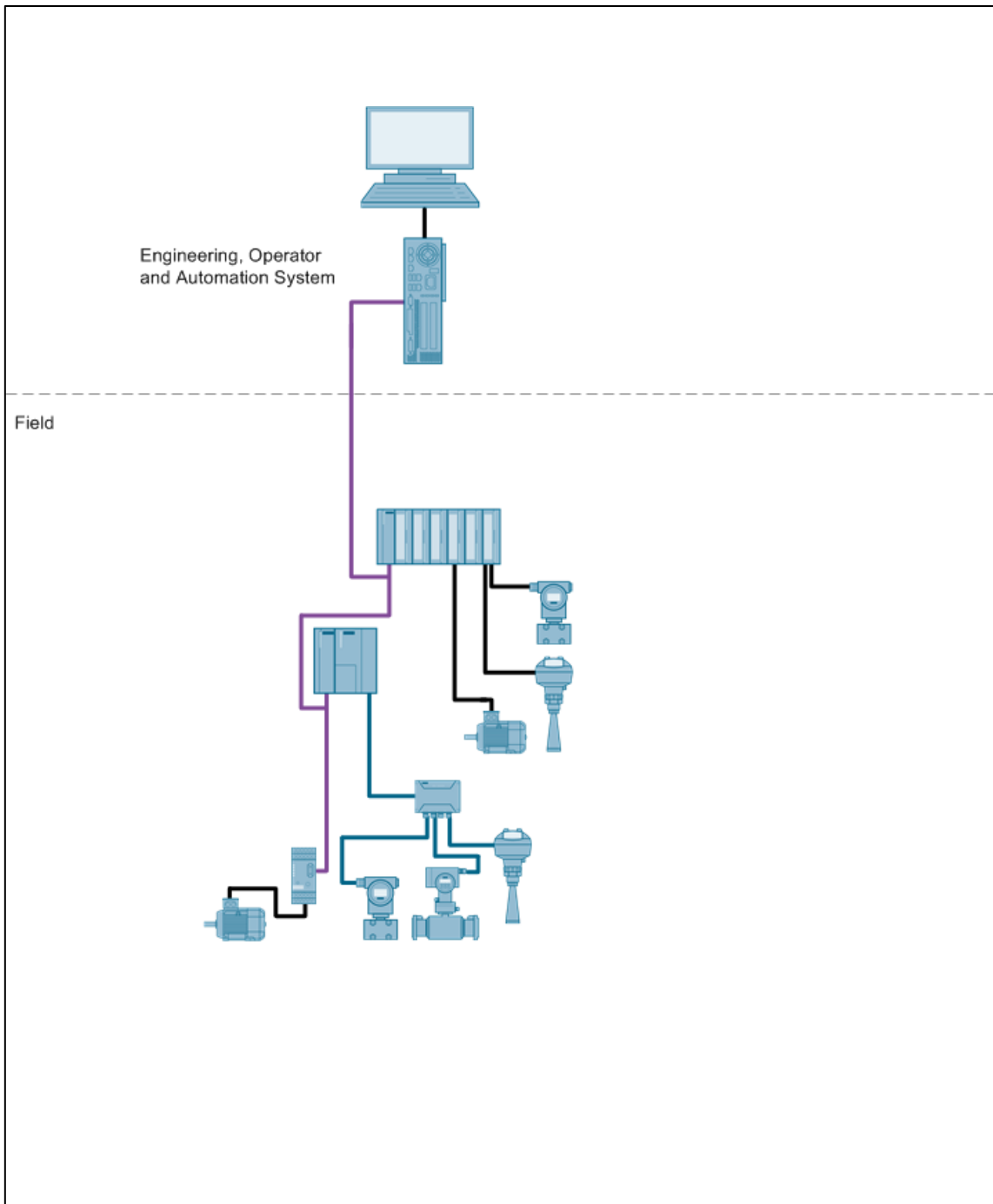

Bill of material for the Starter System with 250 process objects

Table 18–1

Required	Optional	Product number	Product description	Note
Engineering, operator and automation system				
1		6ES7650-4AA11-0GA0	SIMATIC PCS 7 BOX RTX V8.0 SP1 ALL-IN-ONE SYSTEM (ES, OS AND AS)	¹⁾
	1	6ES7 652-0XD08-2YB5	SOFTWARE SIMATIC PCS 7 SFC VISUALIZATION V8.0	

Note

¹⁾ Please use the PCS 7 BOX configurator, as the PCS 7 BOX is available in different versions, e.g. 24V DC or 110/230V AC.

18.2 Single-user System with 1000 process objects

Figure 18-2

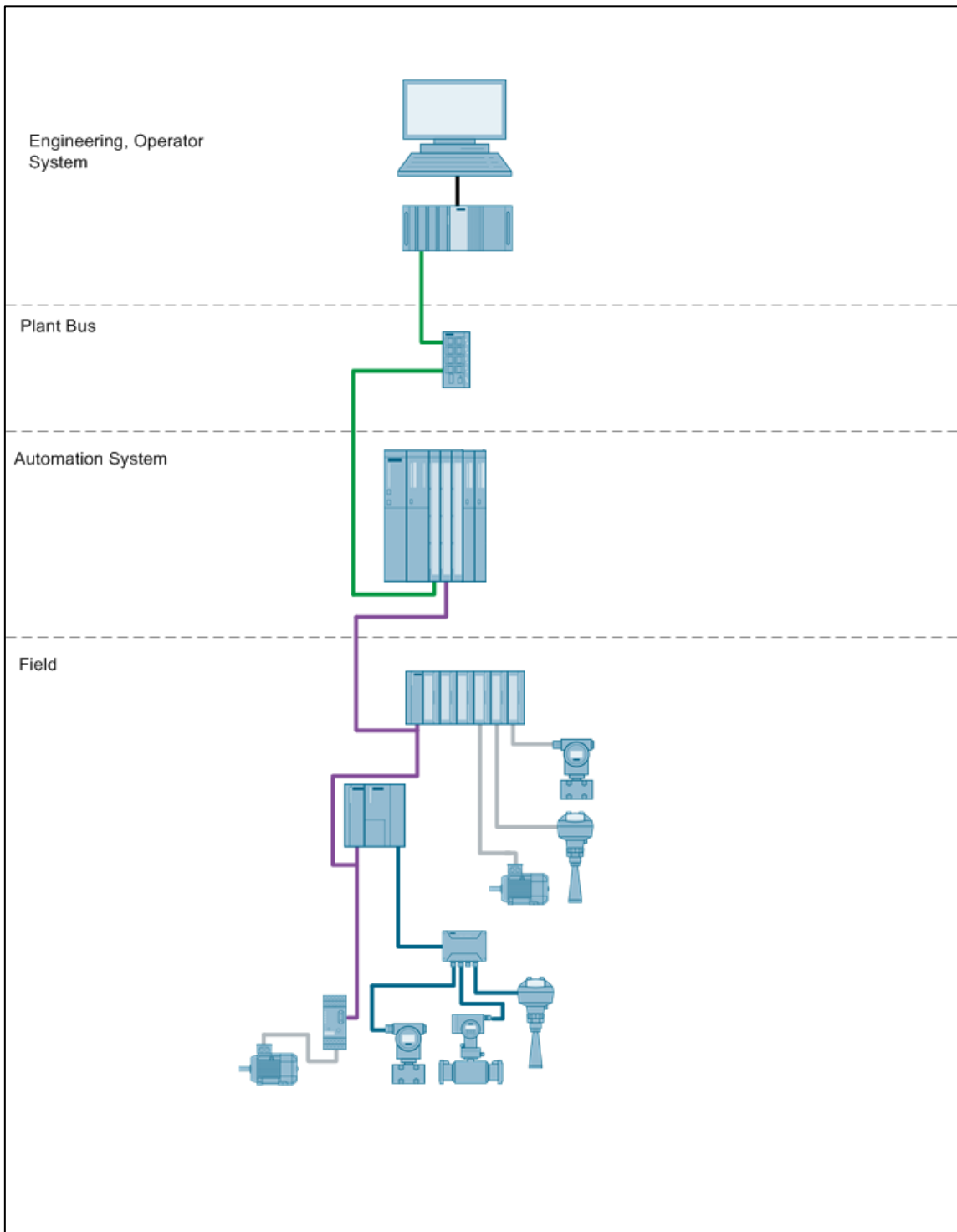

Bill of material for the Single-user System with 1000 process objects

Table 18–2

Required	Optional	Product number	Product description	Note
Engineering System and Operator System				
1		6ES7660-2AA30-1CA0	SIMATIC PCS 7 INDUSTRIAL WORKSTATION IPC847C, CORE I7, ES/OS SINGLESTATION, RAID1 (500GB INTERNAL), 8GB DDR3, BCE, PCS 7 V8.0 SP1, WIN 7	
1		6ES7 658-5AX08-0YA5	SOFTWARE SIMATIC PCS 7 AS/OS ENGINEERING V8.0	
1		6ES7 658-2AA08-0YA0	SOFTWARE SIMATIC PCS 7 OS SOFTWARE SINGLE STATION V8.0 (PO 100)	1)
9		6ES7 658-2XA00-0XB0	SOFTWARE SIMATIC PCS 7 OS RUNTIME LICENSE (PO 100)	
1		6ES7 652-0XD08-2YB5	SOFTWARE SIMATIC PCS 7 SFC VISUALIZATION V8.0	
1		6ES7 658-1CX17-2YA5	SOFTWARE SIMATIC PCS 7 VERSION CROSS MANAGER V7.1	
1		6ES7 658-1FX08-2YA5	SOFTWARE SIMATIC PCS 7 VERSION TRAIL V8.0	
1		6ES7 658-1DX08-2YB5	SOFTWARE SIMATIC PCS 7 IMPORT EXPORT ASSISTANT V8.0	
9		6ES7 653-2BA00-0XB5	SOFTWARE SIMATIC PCS 7 RUNTIME LICENSE AS (PO 100)	
System bus				
1		6GK5 208-0BA10-2AA3	SIMATIC NET SCALANCE X208, MANAGED IE SWITCH, 8 X 10/100MBIT/S	2)
2		6XV1 870-3QH60	SIMATIC NET INDUSTRIAL ETHERNET TP CORD CABLE RJ45/RJ45, 6M	
Automation system				
1		6ES7654-6CN03-3BF0	SIMATIC PCS 7 SINGLE AS, CPU 410-5H, 1X DP-MODULE, 1x PROFINET-IO, SYSTEM EXPANSIONS CARD 1000 PO, AS RT PO 100, CP443-1IE, UR2 ALU RACK, 1 X UC 120/230V 10A POWER SUPPLY	3)

Note

1) The number of POs can be increased later on by means of extra volume licenses.

2) SCALANCE switch requires a 24VDC power supply (not listed).

3) Please use the PCS 7 AS configurator, as the PCS 7 AS 410-5H is available in different versions, e.g. 24V DC or 110/230V AC.

18.3 Client/server system with 2000 process objects

Figure 18-3

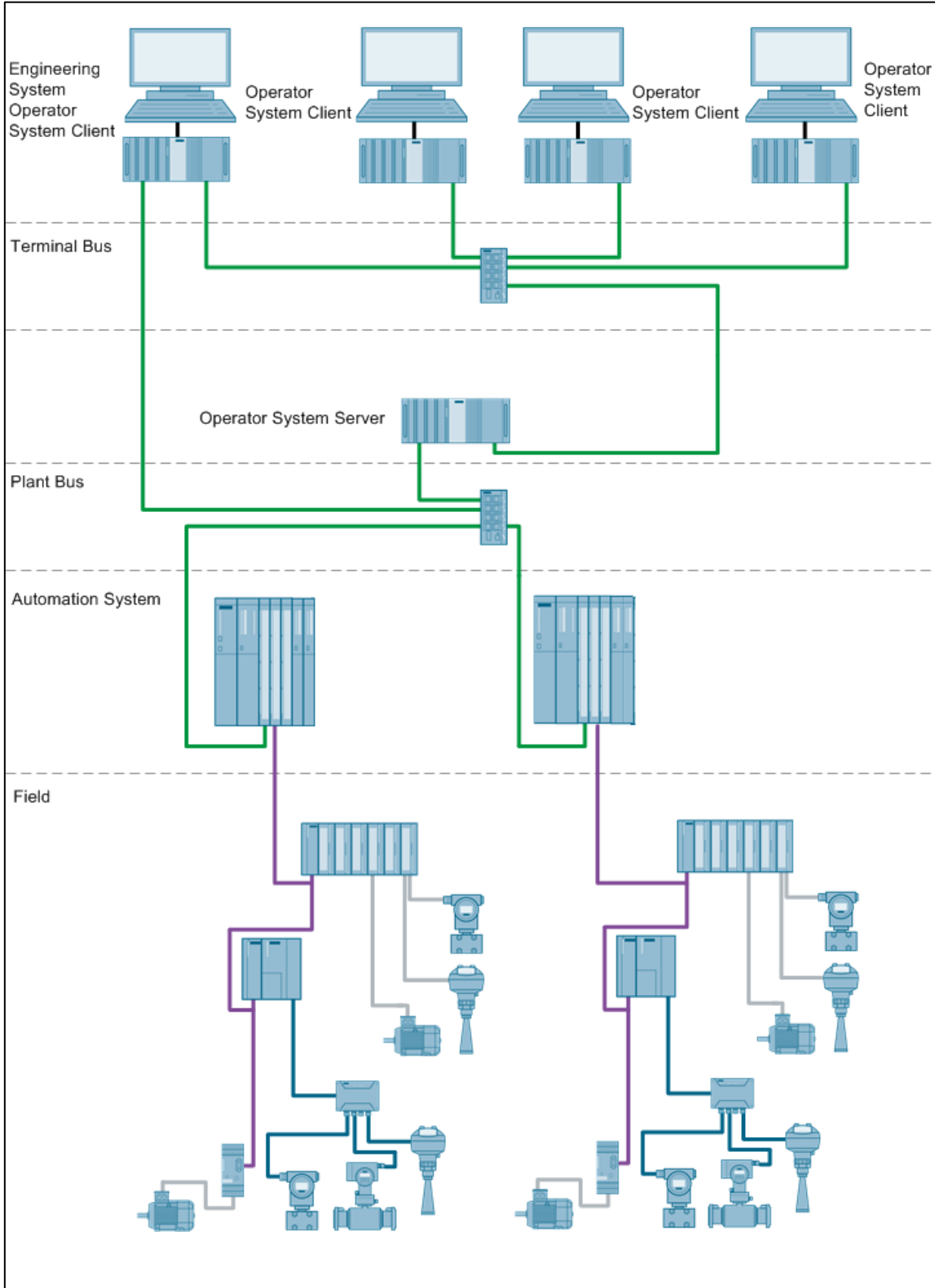

Copyright © Siemens AG 2013 All rights reserved

Bill of material for the client/server system with 2000 process objects

Table 18–3

Required	Optional	Product number	Product description	Note
Engineering System and Operator System client				
1		6ES7660-2AA30-1CA0	SIMATIC PCS 7 INDUSTRIAL WORKSTATION IPC847C, CORE I7, ES/OS SINGLESTATION, RAID1 (500GB INTERNAL), 8GB DDR3, BCE, PCS 7 V8.0 SP1, WIN 7	
1		6ES7 658-5AX08-0YA5	SOFTWARE SIMATIC PCS 7 AS/OS ENGINEERING V8.0	
	1	6ES7 658-1CX17-2YA5	SOFTWARE SIMATIC PCS 7 VERSION CROSS MANAGER V7.1	
	1	6ES7 658-1FX08-2YA5	SOFTWARE SIMATIC PCS 7 VERSION TRAIL V8.0	
	1	6ES7 658-1DX08-2YB5	SOFTWARE SIMATIC PCS 7 IMPORT EXPORT ASSISTANT V8.0	
1		6ES7 658-2CX08-0YB5	SOFTWARE SIMATIC PCS 7 OS CLIENT V8.0	
	1	6ES7 652-0XD08-2YB5	SOFTWARE SIMATIC PCS 7 SFC VISUALIZATION V8.0	
1		6ES7653-2BB00-0XB5	SOFTWARE SIMATIC PCS 7 RUNTIME LICENSE AS (PO 1000)	
9		6ES7653-2BA00-0XB5	SOFTWARE SIMATIC PCS 7 RUNTIME LICENSE AS (PO 100)	
Operator System server				
1		6ES7660-2BA30-1DA0	SIMATIC PCS 7 INDUSTRIAL WORKSTATION IPC847C, CORE I7, OS SERVER, RAID1 (500GB INTERNAL), 8GB DDR3, BCE, PCS 7 V8.0 SP1, WIN SERVER 2008	
1		6ES7 658-2BA08-0YA0	SOFTWARE SIMATIC PCS 7 OS SOFTWARE SERVER V8.0 (PO 100)	
1		6ES7 658-2XB00-0XB0	SOFTWARE SIMATIC PCS 7 OS RUNTIME LICENSE (PO 1000)	
8		6ES7 658-2XA00-0XB0	SOFTWARE SIMATIC PCS 7 OS RUNTIME LICENSE (PO 100)	
Operator System client				
3		6ES7660-1CA18-1CA0	SIMATIC PCS 7 INDUSTRIAL WORKSTATION IPC647C, CORE I7, OS CLIENT, 500GB INTERNAL, 4GB DDR3, PCS 7 V8.0 SP1, WIN 7	
3		6ES7 658-2CX08-0YB5	SOFTWARE SIMATIC PCS 7 OS CLIENT V8.0	
	3	6ES7 652-0XD08-2YB5	SOFTWARE SIMATIC PCS 7 SFC VISUALIZATION V8.0	

Required	Optional	Product number	Product description	Note
Terminal bus				
1		6GK5 208-0BA10-2AA3	SIMATIC NET SCALANCE X208, MANAGED IE SWITCH, 8 X 10/100MBIT/S	1)
4		6XV1 870-3QH60	SIMATIC NET INDUSTRIAL ETHERNET TP CORD CABLE RJ45/RJ45, 6M	
System bus				
1		6GK5 208-0BA10-2AA3	SIMATIC NET SCALANCE X208, MANAGED IE SWITCH, 8 X 10/100MBIT/S	1)
4		6XV1 870-3QH60	SIMATIC NET INDUSTRIAL ETHERNET TP CORD CABLE RJ45/RJ45, 6M	
Automation system				
2		6ES7654-6CN03-3BF0	SIMATIC PCS 7 SINGLE AS, CPU 410-5H, 1X DP-MODULE, 1x PROFINET-IO, SYSTEM EXPANSIONS CARD 1000 PO, AS RT PO 100, CP443-1IE, UR2 ALU RACK, 1 X UC 120/230V 10A POWER SUPPLY	2)

Note

¹⁾ SCALANCE switch requires a 24VDC power supply (not listed).

²⁾ Please use the PCS 7 AS configurator, as the PCS 7 AS 410-5H is available in different versions, e.g. 24V DC or 110/230V AC.

18.4 Redundant client/server system with 3000 process objects

Figure 18-4

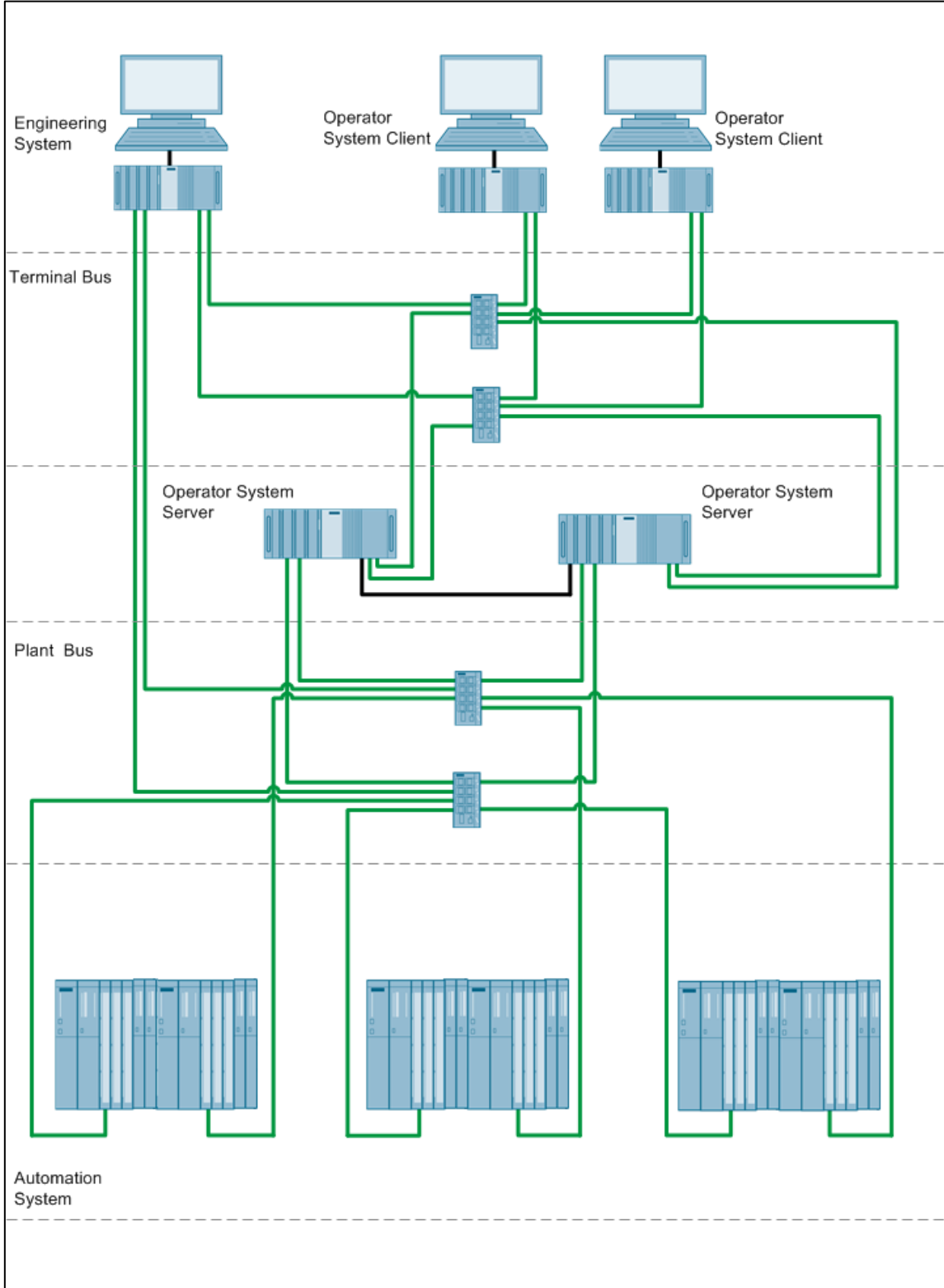

Copyright © Siemens AG 2013 All rights reserved

Bill of material for the redundant client/server system with 3000 process objects

Table 18–4

Required	Optional	Product number	Product description	Note
Engineering System				
1		6ES7 660-2AA31-1CA0	SIMATIC PCS 7 INDUSTRIAL WORKSTATION IPC847C, CORE I7, ES/OS SINGLESTATION, RAID1 (500GB FRONT MOUNTED), 8GB DDR3, INDUSTRIAL ETHERNET (CP1623), PCS 7 V8.0 SP1, WIN 7	
1		6ES7 658-5AX08-0YA5	SOFTWARE SIMATIC PCS 7 AS/OS ENGINEERING V8.0	
1		6GK1 162-3AA00	SIMATIC NET COMMUNICATION PROCESSOR CP 1623 PCI EXPRESS	1)
1		6GK1 716-0HB08-1AC0	SIMATIC NET, S7-REDCONNECT POWERPACK	3)
1		6ES7 652-0XX01-1XF1	SIMATIC PCS 7 REDUNDANT TERMINAL BUS ADAPTER PACKAGE, 2 X INTEL PCI-E (EXPRESS) NETWORK CARD	2)
1		6ES7 658-1CX17-2YA5	SOFTWARE SIMATIC PCS 7 VERSION CROSS MANAGER V7.1	
1		6ES7 658-1FX08-2YA5	SOFTWARE SIMATIC PCS 7 VERSION TRAIL V8.0	
1		6ES7 658-1DX08-2YB5	SOFTWARE SIMATIC PCS 7 IMPORT EXPORT ASSISTANT V8.0	
2		6ES7653-2BB00-0XB5	SOFTWARE SIMATIC PCS 7 RUNTIME LICENSE AS (PO 1000)	
7		6ES7653-2BA00-0XB5	SOFTWARE SIMATIC PCS 7 RUNTIME LICENSE AS (PO 100)	
Operator System server				
2		6ES7660-2BB31-1DA0	SIMATIC PCS 7 INDUSTRIAL WORKSTATION IPC847C, CORE I7, OS SERVER, RAID1 (500GB FRONT MOUNTED), 8GB DDR3, INDUSTRIAL ETHERNET (CP1623), PCS 7 V8.0 SP1, WIN SERVER 2008	
1		6ES7 652-3BA08-2YA0	SOFTWARE SIMATIC PCS 7 OS SERVER REDUNDANCY V8.0 (PO 100)	6)
4		6ES7 658-2XB00-0XB0	SOFTWARE SIMATIC PCS 7 OS RUNTIME LICENSE (PO 1000)	
18		6ES7 658-2XA00-0XB0	SOFTWARE SIMATIC PCS 7 OS RUNTIME LICENSE (PO 100)	
2		6GK1 162-3AA00	SIMATIC NET COMMUNICATION PROCESSOR CP 1623 PCI EXPRESS	1)
2		6GK1 716-0HB08-1AC0	SIMATIC NET, S7-REDCONNECT POWERPACK	3)
2		6ES7 652-0XX01-1XF1	SIMATIC PCS 7 REDUNDANT TERMINAL BUS ADAPTER PACKAGE, 2 X INTEL PCI-E (EXPRESS) NETWORK CARD	2)

Required	Optional	Product number	Product description	Note
Operator System client				
2		6ES7660-1CA18-1CA0	SIMATIC PCS 7 INDUSTRIAL WORKSTATION IPC647C, CORE I7, OS CLIENT, 500GB INTERNAL, 4GB DDR3, PCS 7 V8.0 SP1, WIN 7	
2		6ES7 652-0XX01-1XF1	SIMATIC PCS 7 REDUNDANT TERMINAL BUS ADAPTER PACKAGE, 2 X INTEL PCI-E (EXPRESS) NETWORK CARD	2)
2		6ES7 658-2CX08-0YB5	SOFTWARE SIMATIC PCS 7 OS CLIENT V8.0	
	2	6ES7 652-0XD08-2YB5	SOFTWARE SIMATIC PCS 7 SFC VISUALIZATION V8.0	
Terminal bus				
2		6GK5 208-0BA10-2AA3	SIMATIC NET SCALANCE X208, MANAGED IE SWITCH, 8 X 10/100MBIT/S	4)
10		6XV1 870-3QH60	SIMATIC NET INDUSTRIAL ETHERNET TP CORD CABLE RJ45/RJ45, 6M	
System bus				
2		6GK5 208-0BA10-2AA3	SIMATIC NET SCALANCE X208, MANAGED IE SWITCH, 8 X 10/100MBIT/S	4)
12		6XV1 870-3QH60	SIMATIC NET INDUSTRIAL ETHERNET TP CORD CABLE RJ45/RJ45, 6M	
Automation system				
3		6ES7656-6CN33-1BF0	SIMATIC PCS 7 REDUNDANCY AS, 2X CPU 410-5H, 2 DP-MODULE, 2X PROFINET-IO, SYSTEM EXPANSION CARD 1000, AS RT PO 100, 2 X 2 10M SYNC-MODULE AND 2 X 1M FO, 2 X CP443-1 IE/PN, 1 X UR2-H ALU RACK, 2 X UC 120/230V 10A RED. POWER SUPPLY	5)

Note

- 1) Required in case a redundant system bus is chosen.
- 2) Required in case a redundant terminal bus is chosen.
- 3) Required in case a redundant system bus or a redundant automation system is chosen.
- 4) SCALANCE switch requires a 24VDC power supply (not listed).
- 5) Please use the PCS 7 AS configurator, as the PCS 7 AS 410-5H is available in different versions, e.g. 24V DC or 110/230V AC.
- 6) The redundant OS server is supplied with an RS-232 serial connection cable. If there is a long distance between the redundant systems, one can use an Ethernet connection as an alternative. This requires additional Ethernet network interface cards in the systems.

18.5 Multi-server System with 5000 process objects

Figure 18-5

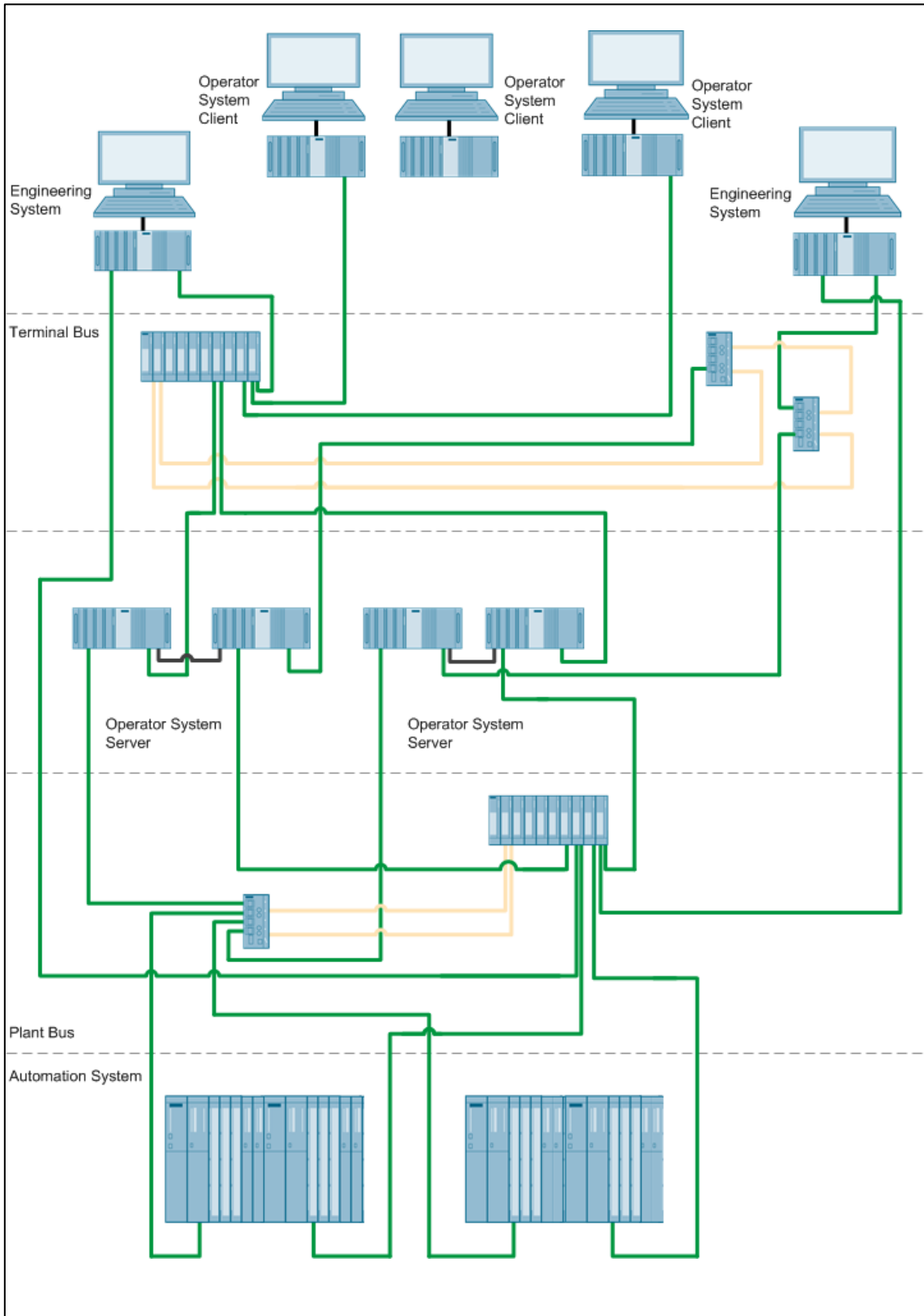

Copyright © Siemens AG 2013 All rights reserved

Bill of material for the Multi-server System with 5000 process objects

Table 18–5

Required	Optional	Product number	Product description	Note
Engineering System				
2		6ES7 660-2AA31-1CA0	SIMATIC PCS 7 INDUSTRIAL WORKSTATION IPC847C, CORE I7, ES/OS SINGLESTATION, RAID1 (500GB FRONT MOUNTED), 8GB DDR3, INDUSTRIAL ETHERNET (CP1623), PCS 7 V8.0 SP1, WIN 7	
2		6GK1 716-0HB08-1AC0	SIMATIC NET, S7-REDCONNECT POWERPACK	1)
2		6ES7 658-5AX08-0YA5	SOFTWARE SIMATIC PCS 7 AS/OS ENGINEERING V8.0	
	2	6ES7 658-1CX17-2YA5	SOFTWARE SIMATIC PCS 7 VERSION CROSS MANAGER V7.1	
	2	6ES7 658-1FX08-2YA5	SOFTWARE SIMATIC PCS 7 VERSION TRAIL V8.0	
	2	6ES7 658-1DX08-2YB5	SOFTWARE SIMATIC PCS 7 IMPORT EXPORT ASSISTANT V8.0	
4		6ES7653-2BB00-0XB5	SOFTWARE SIMATIC PCS 7 RUNTIME LICENSE AS (PO 1000)	
8		6ES7653-2BA00-0XB5	SOFTWARE SIMATIC PCS 7 RUNTIME LICENSE AS (PO 100)	
Operator System server				
4		6ES7660-2BB31-1DA0	SIMATIC PCS 7 INDUSTRIAL WORKSTATION IPC847C, CORE I7, OS SERVER, RAID1 (500GB FRONT MOUNTED), 8GB DDR3, INDUSTRIAL ETHERNET (CP1623), PCS 7 V8.0 SP1, WIN SERVER 2008	
4		6GK1 716-0HB08-1AC0	SIMATIC NET, S7-REDCONNECT POWERPACK	1)
2		6ES7 652-3BA08-2YA0	SOFTWARE SIMATIC PCS 7 OS SERVER REDUNDANCY V8.0 (PO 100)	4)
8		6ES7 658-2XB00-0XB0	SOFTWARE SIMATIC PCS 7 OS RUNTIME LICENSE (PO 1000)	
16		6ES7 658-2XA00-0XB0	SOFTWARE SIMATIC PCS 7 OS RUNTIME LICENSE (PO 100)	
Operator System client				
3		6ES7660-1CA18-1CA0	SIMATIC PCS 7 INDUSTRIAL WORKSTATION IPC647C, CORE I7, OS CLIENT, 500GB INTERNAL, 4GB DDR3, PCS 7 V8.0 SP1, WIN 7	
3		6ES7 658-2CX08-0YB5	SOFTWARE SIMATIC PCS 7 OS CLIENT V8.0	
	3	6ES7 652-0XD08-2YB5	SOFTWARE SIMATIC PCS 7 SFC VISUALIZATION V8.0	

Required	Optional	Product number	Product description	Note
Terminal bus				
1		6GK5 414-3FC00-2AA2	SIMATIC NET SCALANCE X414-3E, MODULAR IE SWITCH, 2 X 10/100/1000MBIT/S	2)
2		6GK5 204-2BB10-2AA3	SIMATIC NET SCALANCE X204-2, MANAGED IE SWITCH, 4 X 10/100MBIT/S	2)
2		6XV1 820-5BN10	SIMATIC NET, FIBER OPTIC CABLE, 4 BFOC CONNECTORS, 10M	
7		6XV1 870-3QH60	SIMATIC NET INDUSTRIAL ETHERNET TP CORD CABLE RJ45/RJ45, 6M	
System bus				
1		6GK5 414-3FC00-2AA2	SIMATIC NET SCALANCE X414-3E, MODULAR IE SWITCH, 2 X 10/100/1000MBIT/S	2)
1		6GK5 204-2BB10-2AA3	SIMATIC NET SCALANCE X204-2, MANAGED IE SWITCH, 4 X 10/100MBIT/S	2)
2		6XV1 820-5BN10	SIMATIC NET, FIBER OPTIC CABLE, 4 BFOC CONNECTORS, 10M	
10		6XV1 870-3QH60	SIMATIC NET INDUSTRIAL ETHERNET TP CORD CABLE RJ45/RJ45, 6M	
Automation system				
2		6ES7656-6CQ33-1BF0	SIMATIC PCS 7 REDUNDANCY AS, 2X CPU 410-5H, 2 DP-MODULE, 2X PROFINET-IO, SYSTEM EXPANSION CARD 2k+, AS RT PO 100, 2 X 2 10M SYNC-MODULE AND 2 X 1M FO, 2 X CP443-1 IE/PN, 1 X UR2-H ALU RACK, 2 X UC 120/230V 10A RED. POWER SUPPLY	3)

Note

- 1) Needed for redundant automation systems.
- 2) SCALANCE switch requires a 24VDC power supply (not listed).
- 3) Please use the PCS 7 AS configurator, as the PCS 7 AS 410-5H is available in different versions, e.g. 24V DC or 110/230V AC.
- 4) The redundant OS server is supplied with an RS-232 serial connection cable. If there is a long distance between the redundant systems, one can use an Ethernet connection as an alternative. This requires additional Ethernet network interface cards in the systems.