

# SINVERT

PVS ComBox 100 / 200

Operating Instructions · 05/2011

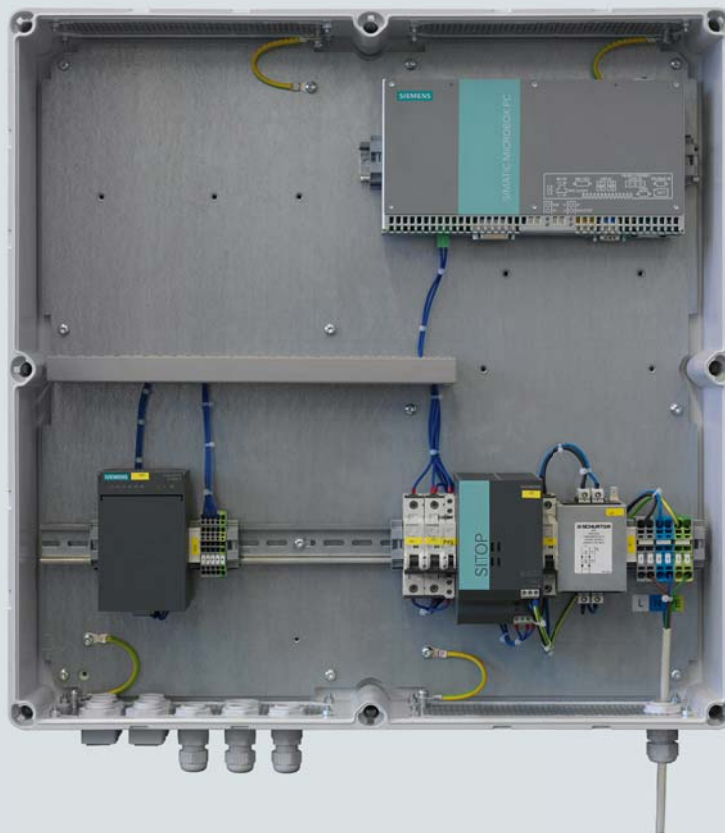

# SINVERT

Answers for industry.

**SIEMENS**



# SIEMENS

## SINVERT

### SINVERT PVS ComBox 100/200

#### Operating Instructions

<u>Introduction</u>	<b>1</b>
<u>Safety instructions</u>	<b>2</b>
<u>Description</u>	<b>3</b>
<u>Application planning</u>	<b>4</b>
<u>Installation</u>	<b>5</b>
<u>Connection</u>	<b>6</b>
<u>Commissioning</u>	<b>7</b>
<u>Parameter assignment</u>	<b>8</b>
<u>Technical data</u>	<b>9</b>
<u>Ordering data</u>	<b>10</b>
<u>Appendix</u>	<b>A</b>

## Legal information

### Warning notice system

This manual contains notices you have to observe in order to ensure your personal safety, as well as to prevent damage to property. The notices referring to your personal safety are highlighted in the manual by a safety alert symbol, notices referring only to property damage have no safety alert symbol. These notices shown below are graded according to the degree of danger.

<b>⚠ DANGER</b>
indicates that death or severe personal injury <b>will</b> result if proper precautions are not taken.

<b>⚠ WARNING</b>
indicates that death or severe personal injury <b>may</b> result if proper precautions are not taken.

<b>⚠ CAUTION</b>
with a safety alert symbol, indicates that minor personal injury can result if proper precautions are not taken.

<b>CAUTION</b>
without a safety alert symbol, indicates that property damage can result if proper precautions are not taken.

<b>NOTICE</b>
indicates that an unintended result or situation can occur if the relevant information is not taken into account.

If more than one degree of danger is present, the warning notice representing the highest degree of danger will be used. A notice warning of injury to persons with a safety alert symbol may also include a warning relating to property damage.

### Qualified Personnel

The product/system described in this documentation may be operated only by **personnel qualified** for the specific task in accordance with the relevant documentation, in particular its warning notices and safety instructions. Qualified personnel are those who, based on their training and experience, are capable of identifying risks and avoiding potential hazards when working with these products/systems.

### Proper use of Siemens products

Note the following:

<b>⚠ WARNING</b>
Siemens products may only be used for the applications described in the catalog and in the relevant technical documentation. If products and components from other manufacturers are used, these must be recommended or approved by Siemens. Proper transport, storage, installation, assembly, commissioning, operation and maintenance are required to ensure that the products operate safely and without any problems. The permissible ambient conditions must be complied with. The information in the relevant documentation must be observed.

### Trademarks

All names identified by ® are registered trademarks of Siemens AG. The remaining trademarks in this publication may be trademarks whose use by third parties for their own purposes could violate the rights of the owner.

### Disclaimer of Liability

We have reviewed the contents of this publication to ensure consistency with the hardware and software described. Since variance cannot be precluded entirely, we cannot guarantee full consistency. However, the information in this publication is reviewed regularly and any necessary corrections are included in subsequent editions.

# Table of contents

<b>1</b>	<b>Introduction</b> .....	<b>7</b>
<b>2</b>	<b>Safety instructions</b> .....	<b>9</b>
<b>3</b>	<b>Description</b> .....	<b>11</b>
	3.1 Design .....	16
	3.2 Function .....	18
	3.3 Scope of delivery .....	19
<b>4</b>	<b>Application planning</b> .....	<b>21</b>
<b>5</b>	<b>Installation</b> .....	<b>23</b>
<b>6</b>	<b>Connection</b> .....	<b>27</b>
	6.1 Connecting the network .....	30
	6.2 Connecting signaling lines .....	32
	6.3 Connecting the power supply.....	32
	6.4 Final tasks.....	33
<b>7</b>	<b>Commissioning</b> .....	<b>35</b>
<b>8</b>	<b>Parameter assignment</b> .....	<b>39</b>
	8.1 Safety notes .....	39
	8.2 Software on the SIMATIC IPC427C industrial PC .....	39
	8.3 Configuration and operation of the SIMATIC IPC427C .....	40
	8.4 SINVERT PVS DataLogger .....	41
	8.4.1 Description .....	41
	8.4.2 Configuration.....	42
<b>9</b>	<b>Technical data</b> .....	<b>49</b>
<b>10</b>	<b>Ordering data</b> .....	<b>53</b>
<b>A</b>	<b>Appendix</b> .....	<b>55</b>
	A.1 Dimension drawings (incl. drilling template) .....	55
	A.2 Abbreviations .....	56
	A.3 Technical support.....	57
	A.4 References.....	58
	<b>Index</b> .....	<b>59</b>



# Introduction

## Purpose of this manual

These operating instructions contain all the information required for assembling, installing, and commissioning the SINVERT PVS ComBox100 and SINVERT PVS ComBox 200.

## Target group

This manual is aimed at qualified personnel in the following target groups:

- Planners
- Fitters
- Commissioning engineers
- Service and maintenance personnel
- Operators

## Basic knowledge required

- Training as an electrical technician
- Experience in working with photovoltaic systems
- Experience in installing and commissioning photovoltaic systems
- Experience of working with inverters

## Conventions

In this manual, the short designations SINVERT PVS ComBox or PVS ComBox are often used for SINVERT PVS ComBox 100 and 200.

## Trademarks

SINVERT® is a registered trademark of Siemens AG.

Currently released editions of this manual:

Edition	Comment
05/2011	Initial release

The SINVERT PVS ComBox is RoHS-compliant. This means the device can be disposed of at local sites for the disposal of household devices.





# Safety instructions

## Qualified personnel

These operating instructions are intended for the following persons:

- Electrical technicians who are commissioning the unit and connecting it to other units in the PV system.
- Service engineers and maintenance engineers who are installing upgrades or performing error analyses.

This documentation is written for qualified personnel. It does not provide basic information about PV systems.

- Only trained specialists may install the unit. The installation engineer must be qualified according to the national guidelines.
- Operation, maintenance, and repair of this device may be made only by qualified staff who are trained to work on or with electrical devices.

## Safety rules



 <b>DANGER</b>
<p><b>Danger due to high voltages</b></p> <p>High voltages cause death or serious injury if safety instructions and notices are not observed or if the equipment is handled incorrectly.</p> <p>Ensure that all work on this equipment is undertaken by appropriately qualified and trained personnel.</p> <p>Keep to the five safety rules at all times and at every stage of work:</p> <ol style="list-style-type: none"><li>1. Isolate</li><li>2. Protect against reconnection</li><li>3. Check that voltage is not present</li><li>4. Ground and short-circuit</li><li>5. Cover nearby live parts or place guards around them</li></ol>



## Description

The SINVERT PVS inverters of a solar power plant are networked together using the SINVERT PVS ComBox.

### Variants

The SINVERT PVS ComBox is currently available in the following versions:

- SINVERT PVS ComBox 100
- SINVERT PVS ComBox 200

### Functional description of the SINVERT ComBox 100

The SINVERT ComBox 100 is used for connecting the SINVERT PVS inverters to the local network (LAN).

The SINVERT ComBox 100 provides 2 options for connecting to the Ethernet LAN:

- Connection by means of copper cable (twisted pair cable with RJ45 connector)
- Connection by means of fiber-optic cable (FOC) in linear and ring topologies

Both connections are possible via a SCALANCE XF204-2 switch. The switch has 4 slots for RJ45 connectors and 2 slots for fiber-optic conductors.

### Areas of application

The following shows 2 examples of communication scenarios for the ComBox 100 with SINVERT PVS inverters.

**Example: Connecting the inverters using fiber-optic cables, connection to the Internet via mobile wireless**

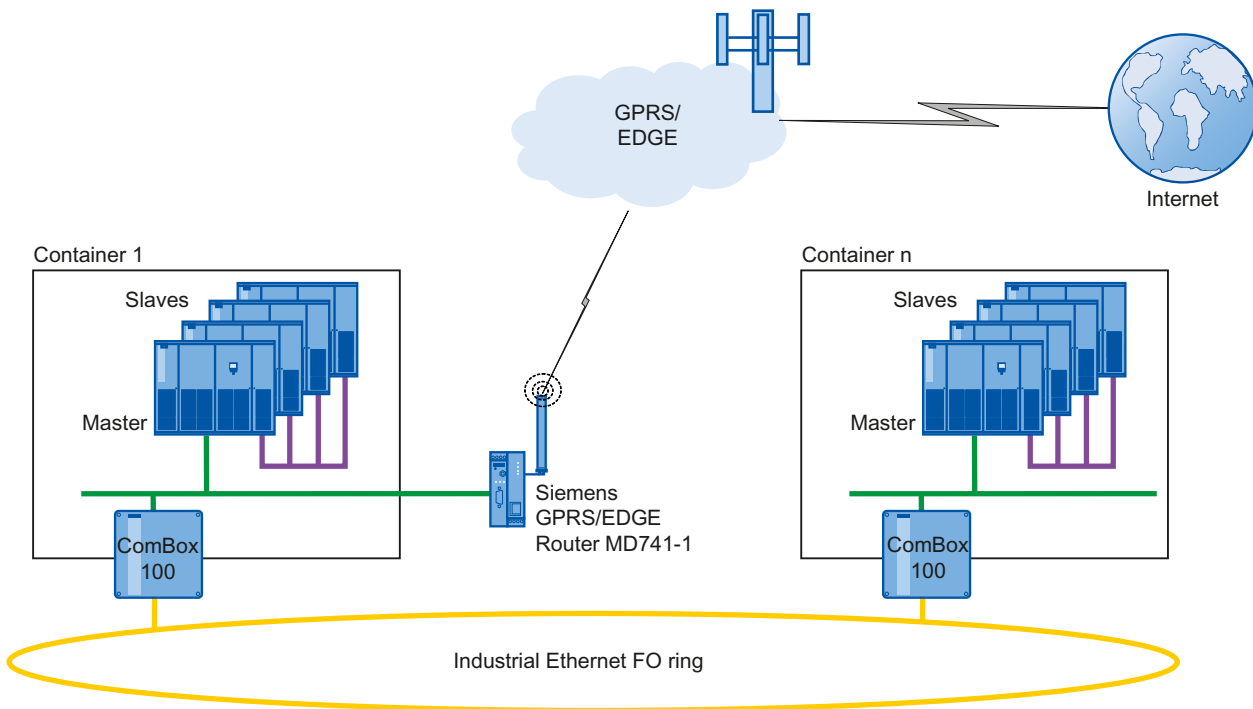

- Yellow: FOC
- Green: Twisted pair
- Violet: Profibus

## Functional description of the SINVERT ComBox 200

The SINVERT PVS ComBox 200 contains the same components as the ComBox 100.

(see Description (Page 11))

In addition, the ComBox 200 contains a SIMATIC IPC427C industrial PC with the following functions:

1. SINVERT PVS DataLogger

The SINVERT PVS DataLogger collects the online data of all of the connected SINVERT PVS inverters, compresses the online data to average values, and transmits them to the SINVERT WebMonitor or to the Web portal of the company meteocontrol GmbH.

You can find further information on the software functionality of the DataLogger in section Parameter assignment (Page 39).

2. Data server for WinCC

If you are using WinCC, you can use the WinAC software PLC as the data server for the WinCC project. The WinCC configuration is created in a project-specific manner and is not part of the ComBox 200.

You can find additional information on the SIMATIC IPC427C industrial PC in the Operating Instructions SIMATIC IPC427C industrial PC

(<http://support.automation.siemens.com/WW/view/en/37028954>).

Areas of application

The example below shows the connection of the SINVERT PVS inverters to the SINVERT WebMonitor.

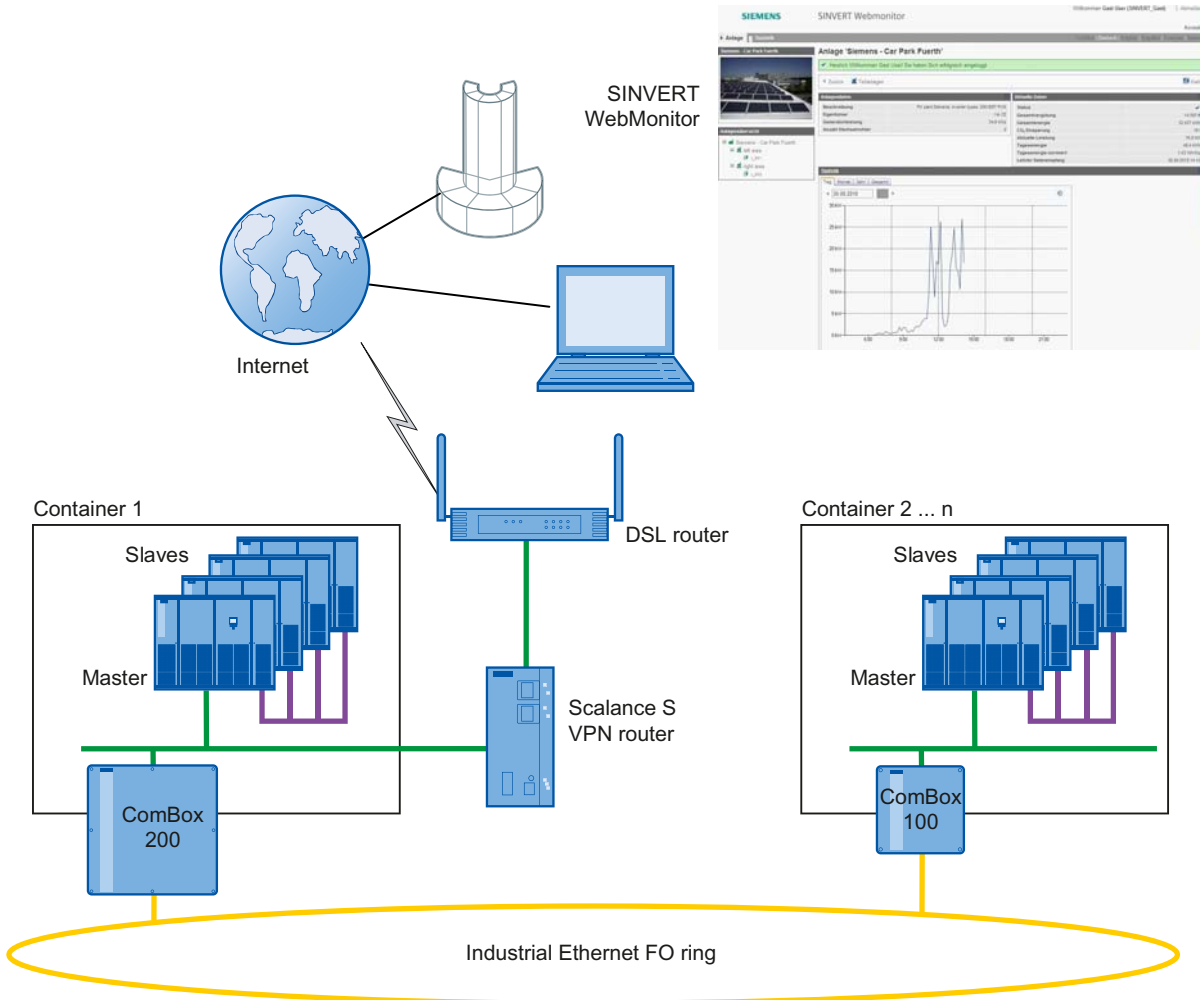

- Yellow: FOC
- Green: Twisted pair
- Violet: Profibus

## General features

The table below provides an overview of the features of the SINVERT PVS ComBoxes 100/200:

Table 3- 1 General features

<b>Feature</b>	<b>PVS ComBox 100</b>	<b>PVS ComBox 200</b>
Heat dissipation by means of convection	✓	✓
Connection by means of copper cable	✓	✓
Connection by means of fiber-optic cable (FOC)	✓	✓
Remote maintenance of the SINVERT PVS inverters via an IPC427C industrial PC	—	✓
Monitoring with the SINVERT WebMonitor	—	✓

### 3.1 Design

#### SINVERT PVS ComBox 100

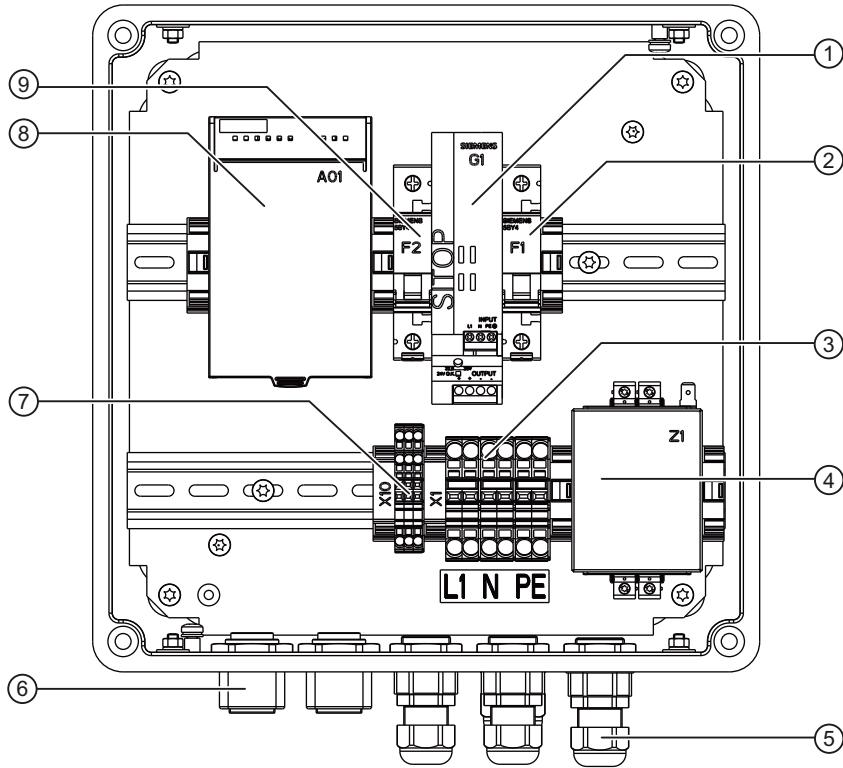

- ① Power supply for ET 200
- ② Fuse: F1
- ③ Terminal strip for the power supply (- X1)
- ④ EMC filter
- ⑤ Cable gland (PG)
- ⑥ Cable gland divisible (KVT)
- ⑦ Terminal strip for signaling lines (- X10)
- ⑧ Scalance (- A01)
- ⑨ Fuse: F2

Figure 3-1 SINVERT PVS ComBox 100



SINVERT PVS ComBox 200

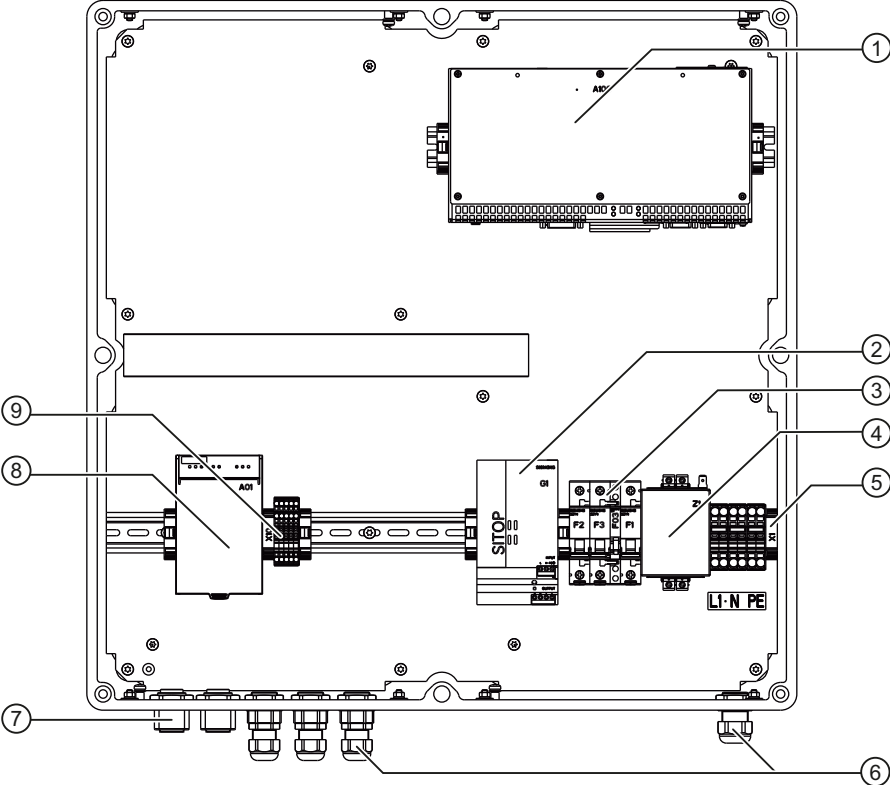

- ① SIMATIC IPC427C industrial PC
- ② Power supply
- ③ Fuses
- ④ EMC filter
- ⑤ Terminal strip for the power supply (- X1)
- ⑥ Cable gland (PG)
- ⑦ Cable gland divisible (KVT)
- ⑧ Scalance (- A01)
- ⑨ Terminal strip for signaling lines (- X10)

Figure 3-2 SINVERT PVS ComBox 200

### 3.2 Function

#### Block diagram of the PVS ComBox 100

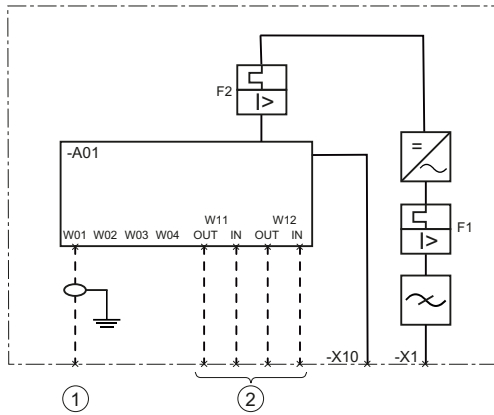

- ① Cable gland divisible (KVT)
- ② Cable gland (PG)

Figure 3-3 Block diagram PVS ComBox 100

#### Block diagram of the PVS ComBox 200

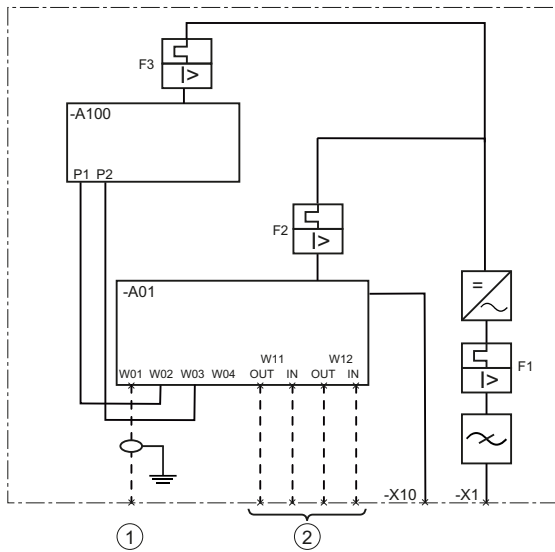

- ① Cable gland divisible (KVT)
- ② Cable gland (PG)

Figure 3-4 Block diagram PVS ComBox 200

## **3.3 Scope of delivery**

### **Scope of delivery**

The scope of delivery of the SINVERT PVS ComBox includes the following:

- SINVERT PVS ComBox 100 or SINVERT PVS ComBox 200
- Cable glands accessories pack
- Operating Instructions

*3.3 Scope of delivery*

## Application planning

Please check that the consignment is complete against the accompanying dispatch documentation. If any items are missing from the consignment, please notify the relevant contact person immediately.

### Storage

When storing the SINVERT PVS ComBoxes, it is essential that you comply with the storage conditions described in section Technical data (Page 49).

The devices must be stored such that they are protected against the ingress of foreign objects and substances.

### Installation location

The PVS ComBox is generally installed in a container next to a PVS inverter system.

The installation location must fulfill the following requirements:

- Solid wall or metal structure
- No direct exposure to sun
- Installation indoors
- Classification as RAL area (Restricted Area Location)

### External line side switch or circuit breaker

An external line side switch or circuit breaker must be provided as an isolating device for the ComBox. The external line side switch or circuit breaker should be located in the vicinity of the ComBox so that it can be unambiguously assigned to the ComBox.



## Installation

### Mounting position

The SINVERT PVS ComBox 100/200 uses pure convection cooling, and is therefore only designed for mounting on a vertical wall.

### Ventilation requirements

A minimum clearance of 20 cm must be provided above the ComBox.

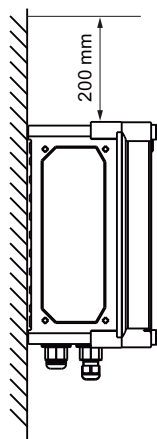

Figure 5-1 Minimum clearance for installation

**Procedure**

The procedures for installing the ComBox 100 and ComBox 200 are the same. They differ only in the number of locking bolts and mounting options:

- PVS ComBox 100: 4 locking bolts and 4 mounting options
- PVS ComBox 200: 8 locking bolts and 8 mounting options

The following instructions describe the installation of the PVS ComBox 200 with 8 locking bolts and 8 mounting options. The PVS ComBox 100 is installed in the same way.

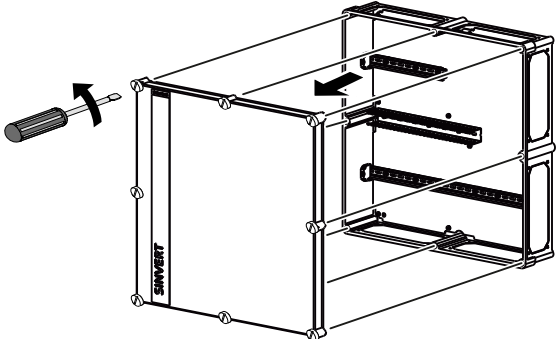
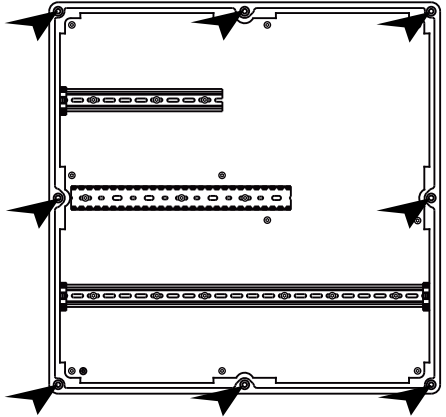
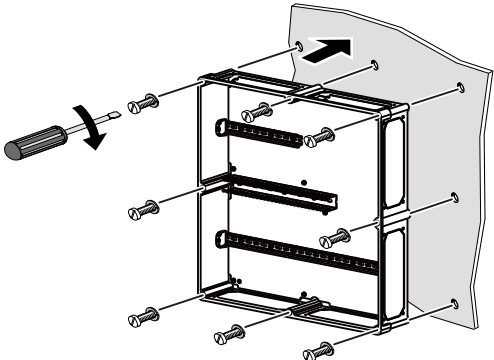
Step	Instruction	Figure
1	<p>Loosen the locking bolts of the cover of the ComBox and remove the cover.</p> <ul style="list-style-type: none"> <li>• To do this, press the locking bolt down slightly and turn it slightly to the left.</li> <li>• Unlock the locking bolt using a Phillips screwdriver. This is done through the opening of the protective cap without disassembling it.</li> </ul>	
2	<p>Drill the drill holes for securing the PVS ComBox as per the dimension drawing (see section Dimension drawings (incl. drilling template) (Page 55)).</p> <ul style="list-style-type: none"> <li>• Use all of the mounting options.</li> </ul>	
3	<p>Screw the SINVERT PVS ComBox firmly into place using suitable screws:</p> <ul style="list-style-type: none"> <li>• Max. torque: 3.5 Nm</li> <li>• To mount on a metal plate, use lens head screws or cylindrical head screws (min. M6 x 50 mm) and M6 washers. To mount on a wall, use round-head screws DIN 7996 6 x L <sup>1)</sup> and M6 washers.</li> <li>• <b>Notice!</b> Countersunk screws are not permissible!</li> <li>• The mounting hardware is not supplied with the device.</li> </ul> <p><sup>1)</sup> Select a suitable length for the round-head screws.</p>	

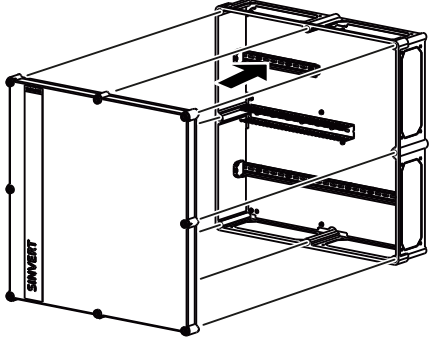
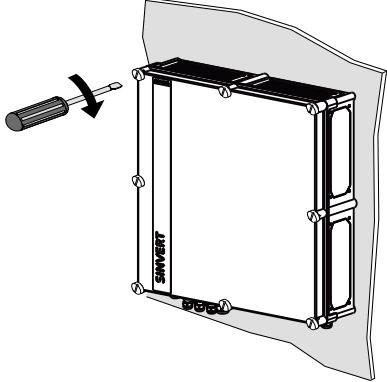

Step	Instruction	Figure
4	Place the cover of the ComBox on the enclosure.	 <p>The diagram shows a wire mesh enclosure with a front panel. A separate cover is being aligned with the top and bottom rails of the enclosure. An arrow points to the top rail where the cover is being positioned.</p>
5	<p>Secure the cover of the ComBox using the locking bolts.</p> <ul style="list-style-type: none"> <li>To do this, press the locking bolt down slightly and turn it slightly to the right. This is done through the opening of the protective cap without disassembling it.</li> </ul>	 <p>The diagram shows a close-up of the cover being secured to the enclosure. A screwdriver is shown turning a locking bolt on the right side of the cover. The bolt is being turned clockwise through a protective cap. The word 'SINVERT' is visible on the left side of the cover.</p>





## DANGER

**Danger, high voltage!**

**Risk of death or serious bodily injury.**

Before starting work, disconnect the system and the devices from the power supply.

### Information on laying the cables

- Ensure that you lay all cables with short-circuit protection and ground fault protection. To ensure short-circuit-proof and ground-fault-proof installation in accordance with VDE 0100-520 (VDE 0100-520:2003-06 Section 521.13 c) or IEC 60364-5-52 (IEC 60364-5-52:1993 Part 5, Chapter 5.2), the following requirements must be fulfilled:
  - Cables must not be installed in the proximity of combustible materials.
  - Ensure the lines are accessible.
  - Prevent the risk of mechanical damage.
  - Comply with the bending radiuses of the cable.
- Do not lay the feeder conductors over edges.
- Make sure that you provide strain relief for the cable.

Overview of the components to be connected for the ComBox 100

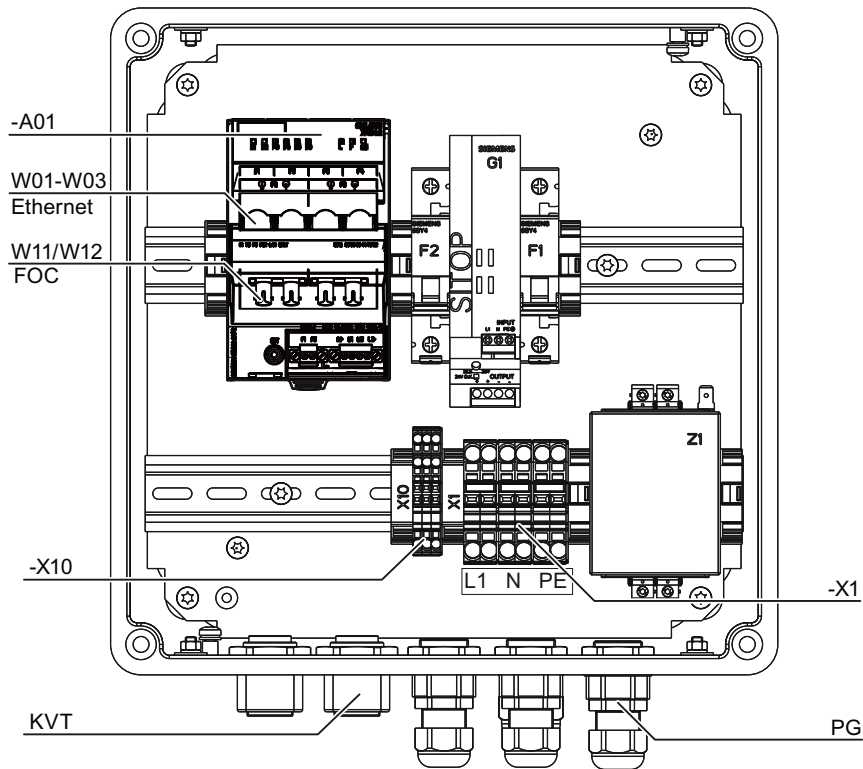

Figure 6-1 SINVERT ComBox 100

- A01 Scalance
- W01 - W03 Ethernet connection to the inverters
- W11, W12 Industrial Ethernet connection to the FOC ring
- X10 Connection to the signaling line
- X1 Power supply connection

Overview of the components to be connected for the ComBox 200

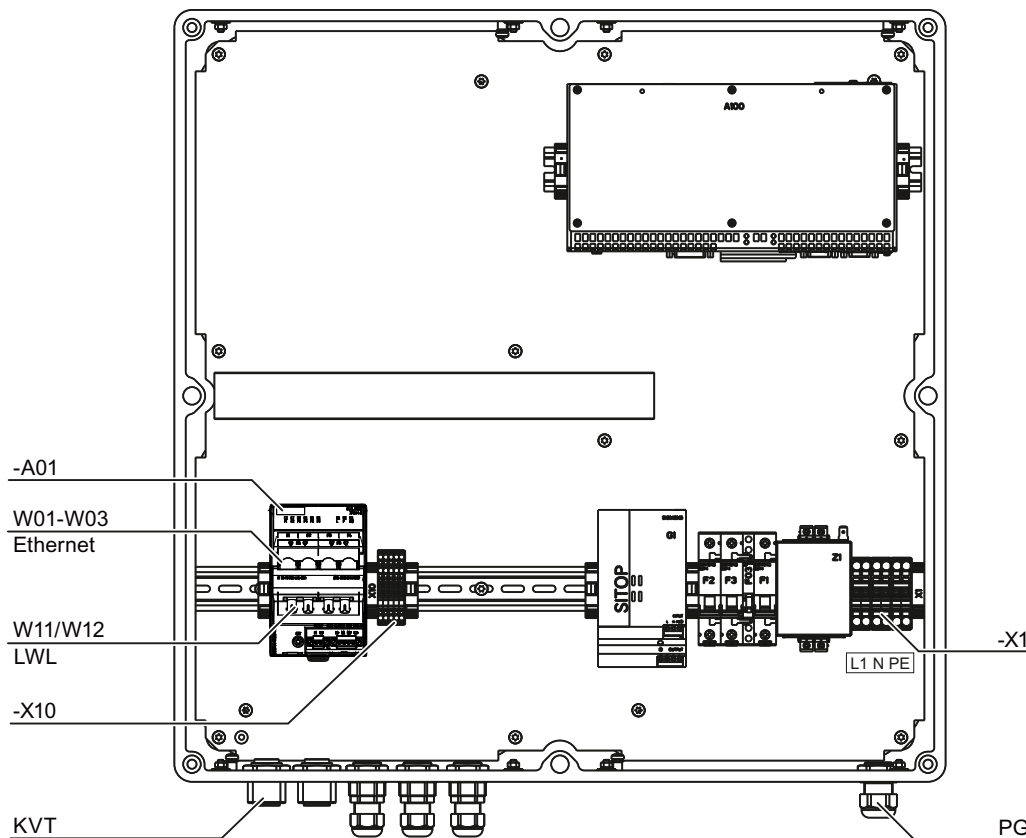

Figure 6-2 SINVERT ComBox 200

- A01 Scalance
- W01 - W03 Ethernet connection to the inverters
- W11, W12 Industrial Ethernet connection to the FOC ring
- X10 Connection to the signaling line
- X1 Power supply connection

**Cable cross-sections**

Comply with the permitted cable cross-sections for the various terminals of the SINVERT PVS ComBox.

Terminal	Function	Terminal type	Cross section and type of cable	
			metric	AWG
-X1	Line voltage L, N, PE	CAGE CLAMP®S	1.5 mm <sup>2</sup> ... 6 mm <sup>2</sup> PE: 6 mm <sup>2</sup>	16 AWG ... 10 AWG PE: 8 AWG
			Solid or finely stranded	
-A01	Ethernet	RJ45	CAT 5e Type: 2YY (ST) CY 2x2x0.75/1.5-100 LI GN	
-A01	FOC	BFOC port (multimode up to 5 km)	A multimode fiber-optic cable (FOC) must be used for transmitting the data. The wavelength is 1310 nm. Multimode fiber-optic cables with a core diameter of 50 or 62.5 μm can be used; the light source is an LED.	
-X10	Signaling lines	CAGE CLAMP®S	0.25 mm <sup>2</sup> ... 1.5 mm <sup>2</sup>	23 AWG ... 16 AWG
			Solid or finely stranded	

**6.1 Connecting the network**

**Connecting to the Industrial Ethernet network with fiber-optic cable**

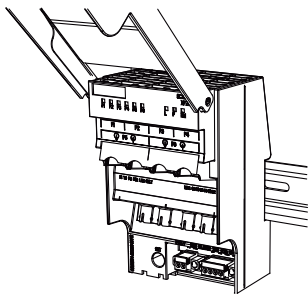

For the Industrial Ethernet network connection, you need a fiber-optic cable with a BFOC port.

Step	Instruction	Figure
<b>1</b>	Route the cables into the ComBox through the cable glands.	
<b>2</b>	Connect the fiber-optic cables directly to the SCALANCE –A01: W11 / W12. <ul style="list-style-type: none"> <li>Ensure there is sufficient bending radius when laying the fiber-optic cables (min. 15 cm).</li> </ul>	

## Connecting to the Ethernet network with RJ45

For the Industrial Ethernet network connection, you need a copper conductor with an RJ45 port.

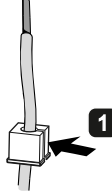
Network cables with RJ45 plugs are routed into the enclosure and provided with strain relief via divisible cable glands (KVTs). The divisible cable glands are included in the scope of delivery and are enclosed with the ComBox as an accessory pack.

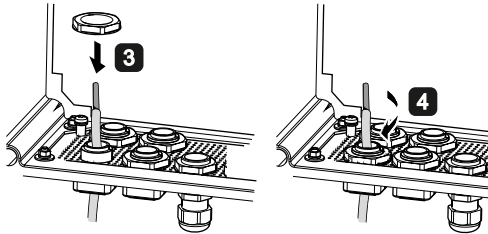
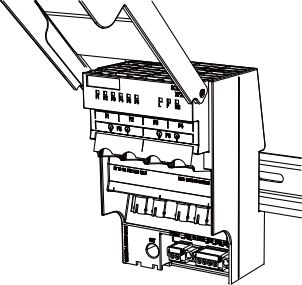
Step	Instruction	Figure
<b>1</b>	Place the pre-assembled network cable into the rubber insert of the divisible cable gland (KVT). The distance from the divisible cable gland to the connector should correspond to the length required to the connection socket.	
<b>2</b>	Close the cable gland (KVT) by pushing the two halves together over the rubber insert until they latch into place.	
<b>3</b> <b>4</b>	Route the network cable with the cable gland (KVT) into the ComBox enclosure and tighten the cable gland using the counter nut provided for this purpose.	
<b>5</b>	Connect the external Ethernet cable direct to the SCALANCE –A01: W01-W03. To do this, insert the RJ45 plug into the twisted pair interface of the SCALANCE X204 until it locks in place.	

### Note

#### Shielding

The shield of the Ethernet cable need not be applied because it contacts the RJ45 plug.

**Exception:** If the Ethernet cable comes from outside of the container, you must apply the shield of the Ethernet cable to the container, and provide overvoltage protection.

## 6.2 Connecting signaling lines

### Connecting signaling lines

Connect the signaling lines to the signaling contacts (floating switches) with which error/fault states are signaled by breaking the contact.

Connect the signaling lines to the terminal strip (-X10).

Route the cables into the ComBox through one of the cable glands (PG).

Terminal	Description
1	Scalance fault message
2	Scalance fault message
<b>Only for SINVERT ComBox 200:</b>	
3	IPC fuse tripped
4	IPC fuse tripped

## 6.3 Connecting the power supply

### Connecting the power supply

**⚠ DANGER**

**Dangerous electrical voltage**

Working with voltages can lead to an electric shock.

Ensure that the power supply cable is disconnected.

#### Note

##### Conductor cross-sections

Select the cross-section of the power supply cable in such a way that the line losses are as low as possible. See the table in section "Connection (Page 27)".

Use a finely stranded cable if possible.

Connect the power supply to the terminal strip (-X1).

Terminal	Description	Circuit diagram
1	L	
2	—	
3	N	
4	—	
5	PE	
6	—	



## **6.4 Final tasks**

### **Final tasks**

1. Close off all the unused connections with dummy plugs.
2. Tighten the cable gland firmly in place.
3. Ensure that the ventilation openings are unobstructed to ensure cooling through convection.



# Commissioning

## Requirements

Check the parameters of the software and adjust them if necessary:

- Configuring SINVERT PVS DataLogger: You can find additional information on configuring the SINVERT PVS DataLogger in chapter SINVERT PVS DataLogger (Page 41).

To operate the SIMATIC IPC427C industrial PC, log on to the SIMATIC IPC427C industrial PC via Remote Desktop (see Configuration and operation of the SIMATIC IPC427C (Page 40))

## Procedure ComBox 100

Proceed as follows to commission the ComBox 100:

1. Close the external line side switch or circuit breaker (see SINVERT PVS DataLogger (Page 41)).
2. Switch in fuses F1 and F2.

## Procedure ComBox 200

Proceed as follows to commission the ComBox 200:

1. Close the external line side switch or circuit breaker (see Connecting the power supply (Page 32)).
2. Switch in fuses F1, F2 and F3.
3. Connect the SIMATIC IPC427C industrial PC to the ON/OFF switch.
4. After approx. 2.5 minutes, the LED RUN on the SIMATIC IPC427C industrial PC shows a green light and the ComBox 200 is ready to operate.

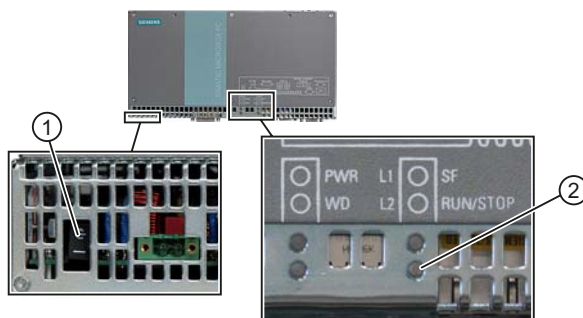

- ① ON/OFF switch
- ② LED RUN

Figure 7-1 SIMATIC IPC427C industrial PC







# Parameter assignment

## 8.1 Safety notes

### Safety notes

<b>NOTICE</b>
<b>SIMATIC IPC427C industrial PC</b> Installing additional software on the SIMATIC IPC427C industrial PC destabilizes the system. Do not install any software on the SIMATIC IPC427C industrial PC.

## 8.2 Software on the SIMATIC IPC427C industrial PC

### Software on the SIMATIC IPC427C industrial PC

The following functions can run on the SIMATIC IPC427C industrial PC:

1. SINVERT PVS DataLogger:  
The SINVERT PVS DataLogger collects the online data of all of the connected SINVERT PVS inverters, compresses the online data to average values, and transmits them to the SINVERT WebMonitor or to the Web portal of the company meteocontrol GmbH.
2. Data server for WinCC  
If you are using WinCC, you can use the WinAC Soft PLC as the data server for the WinCC project. The WinCC configuration is created in a project-specific manner and is not part of the ComBox 200.

## 8.3 Configuration and operation of the SIMATIC IPC427C

### Configuration and operation of the SIMATIC IPC427C industrial PC

To operate the SIMATIC IPC427C industrial PC, log on to the SIMATIC IPC427C industrial PC with the following data via Remote Desktop:

- IP address: 10.80.130.1
- User name: Administrator
- Password: sinvert



Figure 8-1 Remote Desktop connection

Enter the IP address and click on the *connect* button.

After the first log-in, change the usernames and passwords.



## 8.4 SINVERT PVS DataLogger

### 8.4.1 Description

#### Functional description of the SINVERT PVS DataLogger

The SINVERT PVS DataLogger is a Windows service, which is installed on the SIMATIC IPC427C industrial PC of the ComBox 100/200.

The DataLogger collects the online data of all the connected SINVERT PVS inverters, compresses the online data to average values, and transmits the average values to the SINVERT WebMonitor or to the Web portal of the company meteocontrol GmbH.

The DataLogger is installed on the SIMATIC IPC427C industrial PC with Windows XPe.

#### Version

The ComBox 200 is supplied with the SINVERT PVS DataLogger Version 1.0.0.0.

#### Files

The files of the SINVERT PVS DataLogger service can be found in the directory *C:\Program Files\Siemens\SINVERT PVS DataLogger*.

The directory SINVERT PVS DataLogger contains the following files:

File extension	Description
.exe	Program file of the DataLogger
.prop	Configuration files in which the parameters for the communication with the web portal and the Simotions are configured. The parameters in these files must be configured prior to commissioning.
.csv	Text file in csv format, in which the online data of all of the connected SINVERT PVS inverters is saved.
.log	Log file in which error messages and warning messages are recorded.

#### Start DataLogger

SINVERT PVS DataLogger is set up as a Windows service and starts automatically.

Should the DataLogger service not start automatically, you can start it manually in the list via *Start → Settings → Control Panel → Administration → Services*.

When the configuration is complete and free of errors, the service is ready to operate.

If the configuration has errors or is not complete (e.g. no Simotions are set up), the start procedure of the DataLogger is aborted and an error message appears.

You can find error messages in the file "DataLogger\_*Date\_Time*.log" (e.g. DataLogger\_011211\_13-32-18.log).

### Restart DataLogger

To ensure that the parameters take effect after a configuration, you must restart the DataLogger. To do this, open the list of the Windows services via Start → Settings → Control Panel → Administration → Services. Select the DataLogger service from the list and click on restart.

## 8.4.2 Configuration

### Procedure

Proceed as follows to configure the DataLogger:

1. Configure the parameters of the prop files as described in the following chapters.
2. Restart the DataLogger service so that the configuration will take effect.

### Configuration files

The configuration files are structured according to a defined syntax and are supplied with comments.

```
① [ ; *****  
   [ ; TRACE settings  
   [ ; *****  
② [ [LOGGING]  
   [ ; *****  
   [ ; LOG_LEVEL: ERROR, WARNING, INFO  
③ [ ; - ERROR: only errors are traced, recommended for live service  
   [ ; - WARNING: warning and errors are traced  
   [ ; - INFO: everything is traced, only recommended for tests  
   [ ; THIS VALUE MAY BE CHANGED.  
   [ ; *****  
④ [ LOG_LEVEL = ERROR  
   [ ; *****  
③ [ ; Number of log files  
   [ ; THIS VALUE MAY BE CHANGED.  
   [ ; *****  
④ [ LOG_FILE_NUMBER = 5  
① [ Comments on the following section  
② [ Section  
③ [ Comments on the following parameter  
④ [ Definition of the parameter (variable = value)
```

Figure 8-2 Structure of the prop files

<b>NOTICE</b>
<p><b>Structure of the configuration files</b></p> <p>The configuration files are structured according to a defined syntax. If this syntax is changed, the functioning of the DataLogger may be negatively impacted.</p> <p>Do not change the structure of the configuration files.</p>

### Configuration file *settings.prop*

General settings of the DataLogger are configured in the *settings.prop* configuration file.

The following table describes the parameters that are configured in the *settings.prop* configuration file.

[Section] / Parameter	Description	Value range	Default value
[PORTAL]	<p>In the [PORTAL] section, you define which Web portal the DataLogger sends the data to. Delete the semicolon in the line of the Web portal that you would like to integrate:</p> <ul style="list-style-type: none"> <li>SINVERT WebMonitor: <code>siemens_portal_configuration = portal_siemens.prop</code></li> <li>meteocontrol: <code>meteocontrol_portal_configuration = portal_meteocontrol.prop</code></li> </ul> <p>Note: It is not possible to send data to both Web portals at the same time.</p>		
[LOGGING]	The [LOGGING] section defines the properties of the log files.		
LOG_LEVEL	Specifies what types of messages will be recorded in the log file (.log) during communication with the Simotion or the Web portal.	<ul style="list-style-type: none"> <li>ERROR: Only error messages are recorded (recommended when operating)</li> <li>WARNING: Error messages and warning messages are recorded</li> <li>INFO: All messages are recorded (only recommended for test operation)</li> </ul>	ERROR
LOG_FILE_NUMBER	Defines the number of log files that are created. If a log file reaches the parameterized size (see parameter LOG_FILE_SIZE_KB), a new log file is created. The completed log file is saved with the date and time. (e.g. DataLogger_010511_14-36-05.log)	0, 1, 2 ...	5
LOG_FILE_SIZE_KB	Defines the maximum size of the log file in KB.	0, 1, 2 ...	1000
[NETWORK_ADAPTER]	In the [NETWORK_ADAPTER] section, you define which network adapters you control.		
USED_NETWORK_ADAPTER	Specifies the IP address of the network adapter for the Simotion.	<ul style="list-style-type: none"> <li>Empty: The standard network adapter is used.</li> <li>IP address (e.g. 10.80.40.100)</li> </ul>	Empty
[DATA_SOURCE]	In the [DATA_SOURCE] section, you define the data source for the DataLogger.		

8.4 SINVERT PVS DataLogger

[Section] / Parameter	Description	Value range	Default value
DATA_SOURCE	Specifies where the DataLogger gets the data from. When using the ComBox 200, the DataLogger always obtains the data from the Simotion.	It is not recommended that you change this parameter.	SIMOTION
[WINAC]	In the [WINAC] section, you define how the DataLogger communicates with the WinAC. This section is only relevant if the parameter DATA_SOURCE = INTERNAL has been set.		
ACCESSDB	Defines the data block of the solar farm control which the DataLogger accesses.	It is not recommended that you change this parameter.	DB7
[SIMOTION]	In the [SIMOTION] section, you define the Simotion-specific times.		
SIMOTION_TIMEOUT	Specifies the number of seconds after which a connecting process to Simotion is canceled if no connection can be established.	It is not recommended that you change this parameter.	5
SIMOTION_SAMPLE_RATE	Specifies the time intervals in seconds at which the DataLogger calls up data from the Simotion or the solar farm control. If you select too small a value, the DataLogger will calculate a meaningful value and substitute it.	Rule: SIMOTION_SAMPLE_RATE > SIMOTION_TIMEOUT * Number of Simotions / 5	10
[DATA_STORAGE]	In the [DATA_STORAGE] section, you define the storage characteristics of the DataLogger.		
DATA_STORAGE_LIFE	Specifies how many days unsent data is saved in the csv file.	0, 1 ,2 ...	30

**Configuration file *pvddata.prop* (configuration for SINVERT WebMonitor)**

The Simotions that are available in the system are configured in the *pvddata.prop* configuration file. If you would like to establish communication with SINVERT WebMonitor, you must specify the following information for each Simotion:

Information	Description	Value
IP address	IP address of Simotion	IP address in the form: xx.xx.xx.x
Inverter subunit	Number of inverter subunits	Possible values for: <ul style="list-style-type: none"> <li>• PVS500 or PVS600: 1</li> <li>• PVS1000 or PVS1100: 2</li> <li>• PVS1500 or PVS1600: 3</li> <li>• PVS2000 or PVS2400: 4</li> </ul>
Unambiguous number	MAC address	12-digit MAC address in the form: xxxxxxxxxxxx Note: The 12-digit MAC address corresponds to the first part of the registration code, which is included with the inverter.
Serial number of the inverter	Serial number, which has been given to you by your web portal.	The serial number corresponds to the third part of the registration code, which is included with the inverter.
Inverter type	Specifies the type of inverter, the data of which is sent to the web portal.	Possible values: <ul style="list-style-type: none"> <li>• <i>PVS500</i></li> <li>• <i>PVS600</i></li> <li>• <i>PVS1000</i></li> <li>• <i>PVS1100</i></li> <li>• <i>PVS1500</i></li> <li>• <i>PVS1600</i></li> <li>• <i>PVS2000</i></li> <li>• <i>PVS2400</i></li> </ul>
Firmware	Firmware of Simotion	Firmware in the form: <i>Inverter type-x-x-x</i> (e.g. <i>PVS500-1-3-2</i> ).
Date of manufacture	Date of manufacture of the inverter (optionally, the date of the initial commissioning of the inverter can also be specified)	Date of manufacture in the form: YYYY-MM-DD
Change Index	Hotfix version of the Simotion firmware (last digit of the firmware of the Simotion)	Hotfix version in the form: x

8.4 SINVERT PVS DataLogger

Specify the information for each individual Simotion when transferring data to the SINVERT WebMonitor as follows:

```

;Webmonitor:
SIMOTION1 = 10.80.40.1 4 001234567890 TST123456789012 PVS500 PVS500-1-3-2 2011-02-02 1

```

- ① IP address
- ② Inverter subunit
- ③ Number, e.g. MAC address
- ④ Serial number of the inverter
- ⑤ Inverter type
- ⑥ Firmware
- ⑦ Date of manufacture
- ⑧ Change Index

Figure 8-3 SINVERT WebMonitor (pvdata)

Configuration file *portal\_siemens.prop*

The parameters for the SINVERT Webmonitor web portal are configured in the *portal\_siemens.prop* configuration file. Upon delivery, the parameters are configured as described in the table.

Parameters	Description
PORTAL_MAIL_SAMPLE_RATE=600	Defines that the DataLogger determines data every 600 seconds (= 10 minutes) and sends it to the SINVERT Webmonitor.
IP-PORTAL=195.27.237.106	Specifies the IP address of the SINVERT Webmonitor.
PORT_PORTAL=80	Specifies the Internet port.
HOST_PORTAL=www.automation.siemens.com	Specifies the Internet address of the SINVERT Webmonitor.
HTTP_POST=/sinvertwebmonitor	Defines the directory of the SINVERT Webmonitor.

### Configuration file *portal\_meteocontrol.prop*

The parameters for the Meteocontrol web portal are configured in the *portal\_meteocontrol.prop* configuration file. You only have to configure this configuration file if you use the Meteocontrol web portal. The following table describes the parameters that are configured in the *portal\_meteocontrol.prop* configuration file.

Parameters	Description	Value range	Default value
LOGGER_SNR	Serial number, which has been given to you by Meteocontrol.	—	—
UTC_OFFSET	Specifies the deviation from UTC (Coordinated Universal Time). Example: <ul style="list-style-type: none"> <li>• Germany: +1</li> <li>• Portugal: +0</li> </ul>	-12 ... +0 ... +12	—
PORTAL_MAIL_SAMPLE_RATE	Defines the number of seconds after which the DataLogger will determine data.	—	900
PORTAL_MAIL_SEND_RATE	Defines the number of seconds after which the DataLogger will send data to the Meteocontrol web portal.	—	10800
TYPE	Defines the manufacturer from which data will be sent to the Meteocontrol web portal.	—	siemens
FTP_HOST	Defines the FTP host of Meteocontrol.	—	www1.meteocontrol.de
FTP_USER	FTP username, which has been given to you by Meteocontrol.	—	—
FTP_PASSWORD	FTP password, which has been given to you by Meteocontrol.	—	—





## Technical data

### Electrical data

Order No.	6AG3611-3AB00-1AA0	6AG3611-3AB00-2AA0
Power supply:	170 V AC to 264 V AC at 50/60 Hz	
Power consumption:	0.65 A	2.1 A
Protection class	1	

### Ambient conditions

Order No.	6AG3611-3AB00-1AA0	6AG3611-3AB00-2AA0
<b>General</b>		
Cooling method	Natural convection	
Ambient temperature during operation		
• ComBox 100	Up to 50°C	
• ComBox 200	Up to 49°C	
Ambient temperature during storage	-40°C to +70°C	
Relative humidity	0 ... 95% (without condensation)	
Installation altitude	Up to 2000 m above sea level	
Type of installation	Indoor installation	
Operation	3K3 according to EN 60721-3-3	
Cold	Test standard IEC 60068-2-1 (Test AD)	
Dry heat	Test standard IEC 60068-2-2 (Test Bd)	
Humid heat	Test standard IEC 60068-2-78 (Test Cab)	
Temperature change with defined speed of change	Test standard IEC 60068-2-14 (Test Nb)	
Transport and storage	2K4 according to EN 60721-3-2	
Cold	Test standard IEC 60068-2-1 (Test Ab)	
Dry heat	Test standard IEC 60068-2-2 (Test Bb)	
Humid heat, cyclic	Test standard IEC 60068-2-30 (Test Db)	
Rapid temperature change	Test standard IEC 60068-2-14 (Test Na)	

## Electromagnetic compatibility

Order No.	6AG3611-3AB00-1AA0	6AG3611-3AB00-2AA0
<b>Interference emission</b>	<b>EN 61000-6-4, industrial sector</b>	
Conducted	EN 61000-6-4; IEC 61131-2 (no residential areas)	
	Test standards:	
	<ul style="list-style-type: none"> <li>• IEC/CISPR 16-2-1, 7.4.1</li> <li>• IEC/CISPR 16-1-2, 4.3</li> <li>• IEC/CISPR 14-1</li> </ul>	
Field-based	EN 61000-6-4; IEC 61131-2 (no residential areas)	
	Test standards:	
	<ul style="list-style-type: none"> <li>• IEC/CISPR 16-2-3</li> </ul>	
Telecommunications sector	EN 61000-6-4 (no residential areas)	
	Test standard CISPR 22	
<b>Immunity to interference</b>	<b>EN 61000-6-2</b>	
Burst pulses (fast transients)	Test standard IEC61000-4-4; tested with 1 kV	
Surge (high-energy pulses)	Test standard IEC61000-4-5, tested with 1 kV (symmetrical) and 2 kV (asymmetrical)	
ESD (electrostatic discharge)	Test standard IEC 61000-4-2; tested with 8 kV air discharge and 6 kV contact discharge	
Radiated narrow-band electromagnetic fields	Test standard IEC 61000-4-3	
Conducted interference induced by RF fields	Test standard IEC 61000-4-6	

## Mechanical properties

Order No.	6AG3611-3AB00-1AA0	6AG3611-3AB00-2AA0
General		
Degree of protection	IP20	
Mounting position	Vertical	
Type of mounting	Wall mounting	
Type of cable entry	From the bottom	
Dimensions (width/height/depth)	307 x 307 x 175 <sup>1)</sup>	614 mm x 614 mm x 175 mm <sup>1)</sup>
Weight	6.4 kg	17.7 kg
<b>Operation</b>	<b>DIN EN 60721-3-3; Cl. 3M3</b>	
Vibratory load	Test standard DIN EN 60068-2-6; Test Fc	
Shock load	Test standard DIN EN 60068-2-27; Test Ea	

<b>Order No.</b>	<b>6AG3611-3AB00-1AA0</b>	<b>6AG3611-3AB00-2AA0</b>
<b>Storage and transport</b>	<b>EN 60721-3-2; Cl. 2M2</b>	
Vibratory load	Test standard DIN EN 60068-2-6; Test Fc	
Shock load	Test standard DIN EN 60068-2-27; Test Ea	
Free fall of the packaged unit	Test standard EN 60068-2-31 Test Ec	
Free fall of the unpackaged unit	Test standard EN 60068-2-31	

<sup>1)</sup> Plus glands. You can find dimensions in the Dimension drawings (incl. drilling template) (Page 55) section.



## Ordering data

### Ordering data

Name	Order number
SINVERT PVS ComBox 100	6AG3611-3AB00-1AA0
SINVERT PVS ComBox 200	6AG3611-3AB00-2AA0



## Appendix

### A.1 Dimension drawings (incl. drilling template)

#### SINVERT ComBox 100

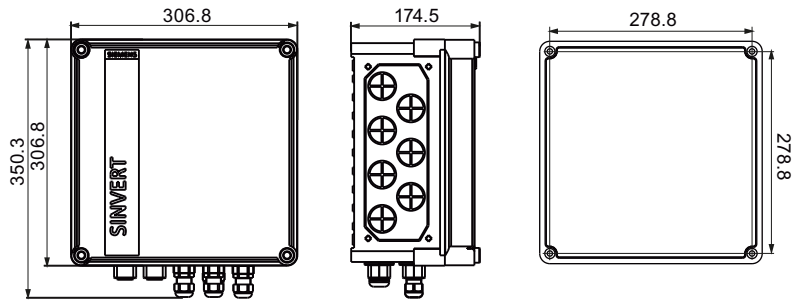

Figure A-1 Dimension drawing of the SINVERT ComBox 100

#### SINVERT ComBox 200

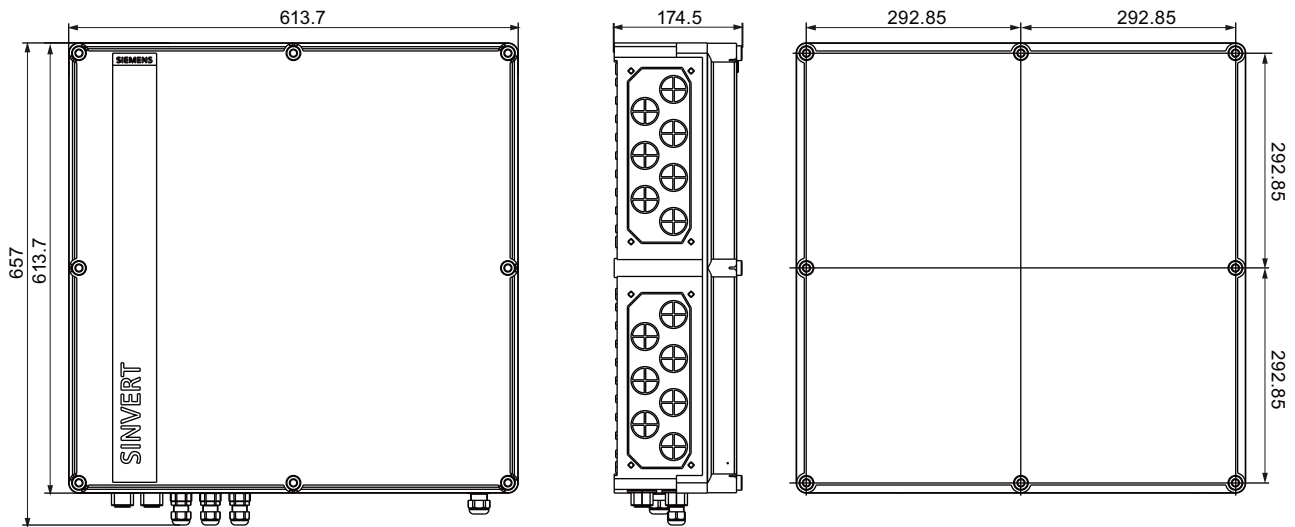

Figure A-2 Dimension drawing of the SINVERT ComBox 200

## A.2 Abbreviations

### Abbreviations

<b>Abbreviation</b>	<b>Meaning</b>
EEG	Renewable Energy Act
BDEW	German Association of Energy and Water Industries
PV	Photovoltaics
FOC	Fiber-optic cable
KVT	Cable gland divisible
PG	Heavy-gauge threaded joint



## A.3 Technical support

### Technical support for SINVERT products

- Information material und downloads for SINVERT products:  
SINVERT infocenter (<http://www.siemens.com/sinvert-infocenter>)  
Here you can find, for example:
  - Catalogs
  - Brochures
- Documentation on SINVERT products:  
SINVERT support (<http://www.siemens.com/sinvert-support>)  
Here you can find, for example:
  - Manuals and operating instructions
  - The latest product information, FAQs, downloads, tips and tricks
  - Characteristics and certificates
- Contacts for SINVERT are available at:  
SINVERT partners (<http://www.siemens.com/sinvert-partner>)

### Technical assistance for SINVERT products

For all technical queries, please contact:

- Phone: +49 (911) 895-5900  
Monday to Friday, 8 am – 5 pm CET
- Fax: +49 (911) 895-5907
- E-mail: Technical assistance (<mailto:technical-assistance@siemens.com>)

## A.4 References

### Directives and laws

- Renewable Energy Act (EEG)
- Energy Industry Act (EnWG)
- Medium Voltage Directive

### Manuals/Operating Instructions

- SIMATIC ET 200S distributed I/O system (SIMATIC ET 200S distributed I/O system (<http://support.automation.siemens.com/WW/view/en/1144348>))
- WinAC Basis V4.0 (WinAC Basis V4.0 (<http://support.automation.siemens.com/WW/view/en/18535320>))
- SENTRON PAC3200 Power Monitoring Device Manual (SENTRON PAC3200 Power Monitoring Device Manual (<http://support.automation.siemens.com/WW/view/en/26504150>))
- SIMATIC industrial PC SIMATIC IPC427C (SIMATIC IPC427C industrial PC (<http://support.automation.siemens.com/WW/view/en/37028954>))

# Index

## A

Areas of application, 12, 14

## B

basic knowledge, 7  
Block diagram, 18

## C

Cable cross-sections, 30  
ComBox 100, 12  
Communication scenarios, 12  
Conventions, 7

## D

DataLogger, 13, 39  
Delivery, 21  
Disposal, 7

## F

Fiber-optic cable, 12, 30

## G

General features, 15

## I

IPC427C, 13

## M

meteocontrol, 13, 39  
Minimum clearance, 23  
Mounting position, 23

## O

Ordering data, 53

## Q

Qualification, 9  
Qualified personnel, 9

## R

RJ45, 12, 31

## S

SCALANCE, 12  
Scope of delivery, 19  
Storage, 21

## T

Target group, 7

## V

Variants, 11  
Ventilation requirements, 23  
Versions, 11

## W

Web portal, 13, 39  
WebMonitor, 13, 39  
WinCC, 13, 39

## Service & Support

Download catalogs and information material:  
[www.siemens.com/sinvert/infomaterial](http://www.siemens.com/sinvert/infomaterial)

Newsletter - always up to date:  
[www.siemens.com/sinvert/newsletter](http://www.siemens.com/sinvert/newsletter)

E-Business in the Industry Mall:  
[www.siemens.com/industrymall](http://www.siemens.com/industrymall)

Online-Support:  
[www.siemens.com/sinvert/support](http://www.siemens.com/sinvert/support)

Contact for all technical information:  
**Technical Assistance**  
Tel.: +49 (911) 895-5900  
E-Mail: [technical-assistance@siemens.com](mailto:technical-assistance@siemens.com)  
[www.siemens.com/sinvert/technical-assistance](http://www.siemens.com/sinvert/technical-assistance)

Siemens AG  
Industry Sector  
Postfach 23 55  
90713 FÜRTH  
GERMANY

Subject to change without prior notice  
Order No.: A5E03642506A-01  
© Siemens AG 2011

[www.siemens.de/industry](http://www.siemens.de/industry)