

# Power Rail Booster

## User Manual

### Version V1.3

08/2001



## Disclaimer of Liability

We have checked the manual for agreement with the hardware and software described. Since deviations cannot be precluded entirely, we cannot guarantee full agreement. However, the data in this manual are reviewed regularly and any necessary corrections included in subsequent editions. Suggestions for improved are welcomed.

## Copyright

Copyright ♥ Siemens AG 2000. All rights reserved

The reproduction, transmission or use of this document or its contents is not permitted without express written authority. Offenders will be liable for damages. All rights, including rights created by patent grant or registration of a utility model or design, are reserved.

Technical data subject to change.

# Table of Contents

## **1 GENERAL INFORMATION..... 6**

### **AREA OF APPLICATION..... 8**

2.1	SUPPORTED PROTOCOLS.....	8
2.2	BEHAVIOR OF THE POWER RAIL BOOSTER AT THE BUS .....	8
2.3	APPLICATION EXAMPLE .....	9

### **INFORMATION ON THE SELECTION AND DIMENSIONING OF THE COLLECTOR WIRES AND SLIDERS..... 10**

INTRODUCTION .....	10	
3.2	COLLECTOR WIRES.....	10
3.3	PERMISSIBLE CABLE LENGTH.....	11
3.4	RING CIRCUITS.....	11
3.5	SLIDERS .....	11
3.5.1	USING DOUBLE SLIDERS .....	11
3.5.2	APPLICATION FORCE .....	11
3.6	COLLECTOR WIRES USED.....	12
3.7	CONTACT RESISTANCES .....	12
3.8	DETERMINING THE CONTACT RESISTANCES .....	13
3.8.1	MEASURING THE INDIVIDUAL RESISTANCES .....	13
3.8.2	MEASURING THE SERIES RESISTANCES OF INDIVIDUAL DOUBLE SLIDERS .....	13
3.8.3	MEASURING THE SERIES RESISTANCES OF BOTH DOUBLE SLIDERS.....	14
3.9	RAIL CUTS .....	15

### **4 MOUNTING..... 17**

4.1	REQUIRED COMPONENTS.....	17
4.2	MOUNTING POSITION.....	17
4.3	MOUNTING RAIL.....	17
4.4	MOUNTING DIMENSIONS .....	18
4.5	REQUIRED TOOL .....	19
4.6	MOUNTING.....	19
4.7	DISMANTLING .....	19

### **5 WIRING ..... 19**

5.1	INTRODUCTION .....	19
5.2	SPECIFIC APPLICATIONS .....	19
5.3	EMERGENCY-OFF DEVICES .....	19
5.4	24V DC SUPPLY .....	20
5.5	PROTECTION AGAINST OUTSIDE ELECTRICAL INFLUENCES .....	20
5.6	OPERATING A POWER RAIL BOOSTER AT A GROUNDED SUPPLY .....	20
5.7	DEFINITION: GROUNDED SUPPLY.....	20
5.9	OPERATING A POWER RAIL BOOSTER WITH UNGROUNDED REFERENCE POTENTIAL.....	22
5.10	COMPONENTS AND PROTECTIVE MEASURES.....	22

VARIOUS COMPONENTS AND PROTECTIVE MEASURES ARE PRESCRIBED WHEN SETTING UP AN ENTIRE PLANT. THE TYPE OF COMPONENTS AND THE DEGREE OF MANDATORINESS DEPEND ON WHICH DIN VDE REGULATION APPLIES FOR YOUR PLANT DESIGN. THE FOLLOWING TABLE REFERS TO FIG. 2. .... 22

5.11	SAFE ELECTRICAL ISOLATION.....	23
5.12	SETTING UP A POWER RAIL BOOSTER WITH GROUNDED REFERENCE POTENTIAL .....	23
5.13	ELECTRICAL DESIGN OF THE POWER RAIL BOOSTER .....	24
5.14	WIRING RULES FOR POWER RAIL BOOSTER .....	25
5.15	WIRING OF THE POWER RAIL BOOSTER.....	25
5.15.1	FEATURES .....	25
5.15.2	PREREQUISITES.....	25
5.15.3	REQUIRED TOOL.....	25
5.15.4	WIRING OF THE POWER RAIL BOOSTER .....	25
5.15.5	DATA CABLES.....	26
5.15.6	FUNCTIONAL GROUND .....	27
5.15.7	SUPPLY VOLTAGE.....	27
5.15.8	PROFIBUS DP.....	28
5.15.9	SIGNALING CONTACT (OPTIONAL).....	28

## **6 COMMISSIONING AND STARTING UP THE POWER RAIL BOOSTER..... 29**

6.1	PLANNING INFORMATION .....	29
6.2	OPERATION AT ADJUSTABLE BUS TIMING .....	29
6.3	SOFTWARE REQUIREMENTS.....	30
6.4	REQUIREMENTS FOR COMMISSIONING .....	30
6.5	TAKING THE POWER RAIL BOOSTER INTO OPERATION .....	31
6.6	STARTING UP THE POWER RAIL BOOSTER .....	31
6.7	STATUS AND FAULT DISPLAYS THROUGH LEDs .....	32
6.8	STATUS AND FAULT DISPLAY THROUGH MESSAGE OUTPUT SF OUT .....	32

## **7 GENERAL TECHNICAL SPECIFICATIONS..... 33**

7.1	WHAT ARE GENERAL TECHNICAL SPECIFICATIONS?.....	33
7.2	STANDARDS AND APPROVALS .....	33
7.2.1	INTRODUCTION.....	33
7.2.2	PROFIBUS STANDARD.....	33
7.2.3	CE APPROVAL.....	33
7.2.4	INFORMATION FOR THE MANUFACTURERS OF MACHINES.....	34
7.2.5	UL APPROVAL (APPLICATION SUBMITTED) .....	34
7.2.6	CSA APPROVAL (APPLICATION SUBMITTED).....	35
7.3	ELECTROMAGNETIC COMPATIBILITY .....	36
7.3.1	DEFINITION.....	36
7.3.2	PULSE-SHAPED INTERFERENCES .....	36
7.3.3	SINUSOIDAL INTERFERENCES .....	37
7.3.4	EMISSION OF RADIO INTERFERENCES .....	37
7.4	TRANSPORTATION AND STORAGE CONDITIONS .....	37
7.5	CLIMATIC AMBIENT CONDITIONS.....	38
7.6	MECHANICAL AMBIENT CONDITIONS .....	38
7.6.1	TESTS FOR MECHANICAL AMBIENT CONDITIONS .....	39
7.7	INFORMATION ON INSULATION TESTING, SAFETY CLASS, DEGREE OF PROTECTION, AND RATED VOLTAGE OF THE POWER RAIL BOOSTER .....	39
7.7.1	TEST VOLTAGE.....	39
7.7.2	POLLUTION SEVERITY/OVERVOLTAGE CATEGORY .....	39
7.7.3	SAFETY CLASS.....	40

7.7.4	DEGREE OF PROTECTION .....	40
7.7.5	ELECTRICAL CONNECTION DATA.....	40
7.7.6	ELECTRICAL CONNECTION DATA OF THE SIGNALING CONTACT .....	40
	CONNECTIONS .....	40
7.8.1	PIN ASSIGNMENT OF THE RS485 INTERFACE (PROFIBUS DP) .....	40
7.8.2	TERMINAL ASSIGNMENT OF THE POWER SUPPLY (24 V DC).....	41
7.8.3	TERMINAL ASSIGNMENT OF THE POWER RAIL INTERFACE (POWER RAIL).....	41
7.8.4	PIN ASSIGNMENT OF THE SIGNALING CONTACT (SF OUT) .....	41
7.9	INTERFACES .....	41
7.10	ORDER NUMBER .....	41

## **8 CONSTANTLY UPDATED INFORMATION..... 42**

## **9 GLOSSARY ..... 43**

## **10 DIRECTORY OF FIGURES..... 47**

# 1 General Information

---

## Safety Information

This manual contains information which you have to observe for your personal safety as well as in order to avoid damage to property. This information is highlighted by a warning triangle and, depending on the degree of danger, one of the following:

---

---



### **Danger**

Means that death, serious injury or considerable damage to property **will** result if the corresponding precautionary measures are not taken.

---

---



### **Warning**

Means that death, serious injury or considerable damage to property can result if the corresponding precautionary measures are not taken.

---

---



### **Caution**

Means that minor injury or damage to property can result if the corresponding precautionary measures are not taken.

---

---

### **Note**

Is an important information on the product, the handling of the product or the corresponding part of the documentation to which particular attention is to be drawn.

---

---

Qualified Personnel Commissioning and operation of a device may only be carried out by **qualified personnel**. Qualified personnel in the sense of the safety instructions in this manual are persons who are entitled to commission, ground and identify devices, systems and circuits in accordance with the standards of safety technology.

---

---

Control Cabinet A **control cabinet** in the sense of these operating instructions has to fulfill the requirements placed on a fire protection enclosure in accordance with EN 60950.

---

---



### Warning

The device is designed for operation in control cabinets or closed equipment rooms.  
The device may not be opened.

---

---

Proper Use The device may only be used for the applications specified in these operating instructions and only in combination with devices and components from other manufacturers which have been recommended or approved by Siemens.

Trouble-free and safe operation of the product requires appropriate transportation, appropriate storage, erection and mounting as well as careful operation and maintenance.

---

## 2 Area of Application

The Power Rail Booster is used to implement a PROFIBUS connection via collector wires, as they occur, for example, in monorail conveyors or high-bay transport systems. In order to ensure secure transfer via the collector wires the data entering via the PROFIBUS DP interface from the various bus stations are amplified to a noise-free level and launched on the conductor bar. Data entering via the conductor bar with noise-free level are converted correspondingly to PROFIBUS DP signals.

The used PROFIBUS baud rate is recognized automatically by the device. Data rates of between 9,600 bits/s and 500 kbits/s are valid for transfer via collector wires.

Each Power Rail Booster segment can feed up to 125 slaves.

For a safe data transfer, there are, beside the Power Rail Booster, no additional filters or termination elements necessary.



### Warning

The project planner must ensure that faults in the data transfer do not lead to dangerous states.

---

### 2.1 Supported Protocols

In addition to PROFIBUS-DP the Power Rail Booster supports PROFIBUS-FMS as well as FDL. The use of variable bus parameters requires an exact knowledge of the meaning of the individual parameters. In particular, the fact that the Power Rail Booster requires up to 6 bit periods per conversion of the data has to be taken into account when changing the parameters.

### 2.2 Behavior of the Power Rail Booster at the Bus

The Power Rail Booster is not an active bus station and therefore does not require a bus address. It allows largely transparent data exchange across a collector wire.

The Power Rail Booster can be used in mono- and multiple-master systems. Active communication partners may only be used at one end of the collector wire.



## 2.3 Application Example

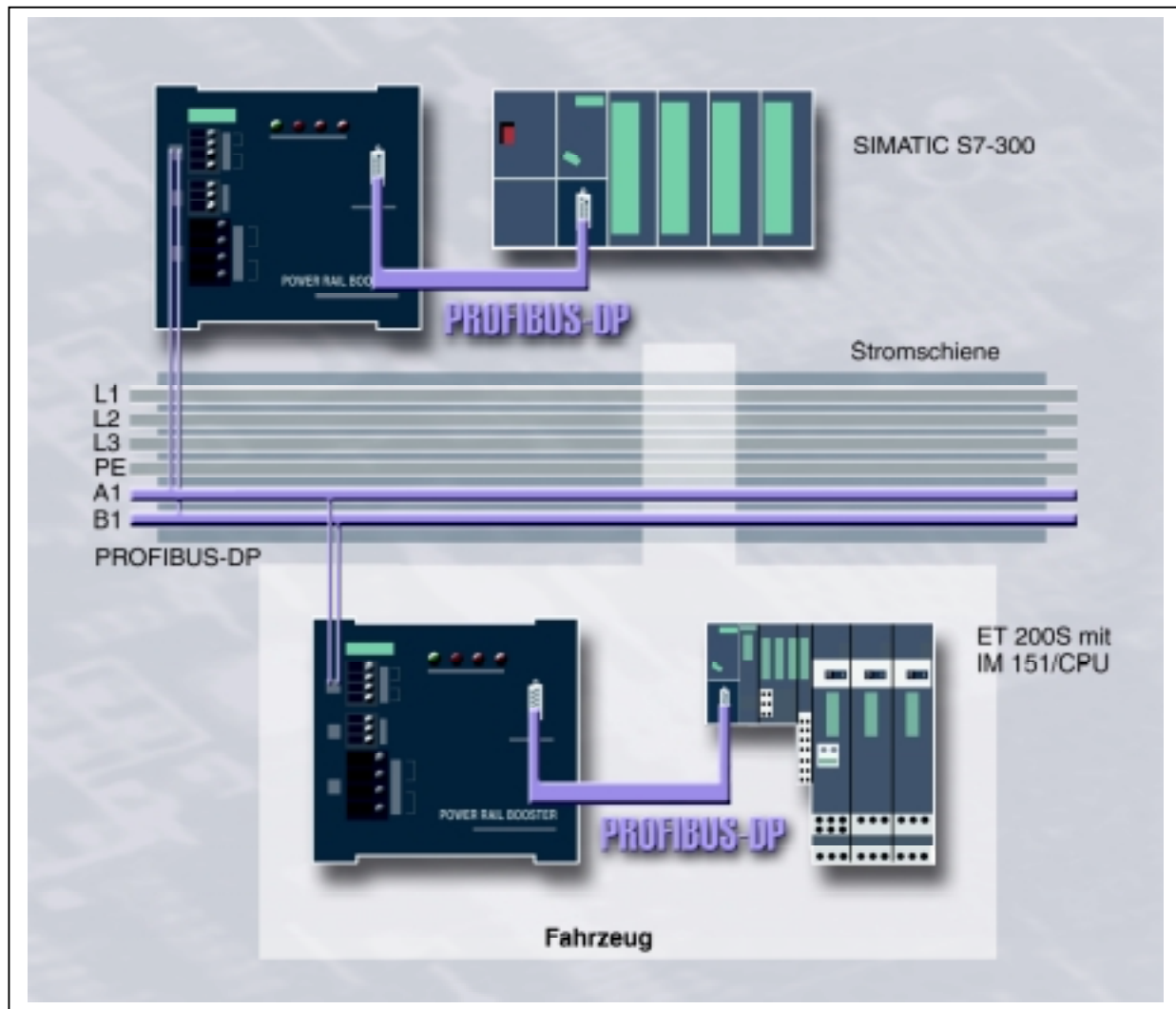

Figure 1: Application example

### **3 Information on the Selection and Dimensioning of the Collector Wires and Sliders**

#### **3.1 Introduction**

The Power Rail Booster allows the transfer from PROFIBUS DP to the bus termination via collector wires without additional components. In order to ensure error-free transfer, meticulous selection of the collector wires and sliders as well as their proper maintenance and care are required in addition to observance of the project planning regulations contained in this manual.

#### **3.2 Collector Wires**

The Power Rail Booster can be used with a large number of common collector wire systems. In addition to open and insulated collector wire systems, box-type collector wire systems with collector wires made of copper (alloys) or stainless steel can be used.

Whereas low line resistance is to be achieved when transferring power, the primary aspect when selecting the collector wires for data transfer via Power Rail Booster is the lower contact resistance between the collector wire and the slider (for further information see Section 3.7 Contact Resistances). Particular attention must therefore be paid to the surface properties of the collector wire used.

Depending on the prevailing ambient conditions soiling and oxidation of the collector wires can arise during the operation of collector wire systems, in particular if copper collector wires are used. However, if sliders travel constantly across a collector wire, a certain self-cleaning effect arises. Particular attention must therefore be paid during maintenance to line sections which are not traveled constantly. These are in particular: Maintenance aisles, storage sidings, outer edges of crane systems and high-bay transport systems, etc.

### 3.3 Permissible Cable Length

The permissible cable length for transferring data with the Power Rail Booster depends on the set data transfer rate.

The following table lists the respective maximum cable lengths as a function of the transfer rate. No requirements are placed on the minimum cable length.

Transfer speed	Maximum rail length
9600 bits/s	1,200 m
19,200 bits/s	600 m
45,450 bits/s	250 m
93,750 bits/s	125 m
187,500 bits/s	62.5 m
500,000 bits/s	25 m

### 3.4 Ring Circuits

The Power Rail Booster supports collector wire systems with cable ends open (electrically at both ends) or in closed ring circuits.

In case of systems with closed ring circuits it is advisable to connect the structural steel with low impedance parallel to the collector wire.

### 3.5 Sliders

#### 3.5.1 Using Double Sliders

The use of mechanically isolated double sliders is recommended in order to ensure secure data transmission.

#### 3.5.2 Application Force

When mounting and setting the sliders ensure that the application force of the slider against the collector wire is sufficient at all positions. If the application force is too low, this may lead to increased bouncing and reduced self-cleaning of the collector wire system - thus causing transfer errors.

### 3.6 Collector Wires Used

The Power Rail Booster can be used with a large number of common collector wires. The primary factor when selecting collector wires for data transfer with the Power Rail Booster is its surface properties. Please also refer to Section 3.7 Contact Resistances.

---

#### Note

Ensure by means of sufficiently frequent maintenance and cleaning intervals that error-free data transfer is not endangered by soiled or oxidized collector wires.

---

### 3.7 Contact Resistances

In case of soiling or oxidation contact resistances which are in part considerable can arise between the sliders and rail. In order to ensure that the data transfer is carried out error-free, these contact resistances may not lie above the values shown in the table below.

The specified resistances represent the sum of the resistances of the two double sliders to the rails.

max. data transfer rate and max. cable capacity / -length	9.600 Bit/s 200 nF / 1200 m	19.200 Bit/s 150 nF / 600 m	45.450 Bit/s 100 nF / 250 m	93.750 Bit/s 70 nF / 125 m	187.500 Bit/s 30 nF / 62,5 m	500.000 Bit/s 10 nF / 25 m
up to 2 slaves	3000 Ω	900 Ω	800 Ω	800 Ω	700 Ω	250 Ω
up to 3 slaves	2000 Ω	700 Ω	700 Ω	700 Ω	500 Ω	200 Ω
up to 5 slaves	1500 Ω	500 Ω	500 Ω	500 Ω	300 Ω	150 Ω
up to 10 slaves	900 Ω	300 Ω	300 Ω	300 Ω	200 Ω	100 Ω
up to 20 slaves	500 Ω	200 Ω	200 Ω	200 Ω	100 Ω	
up to 50 slaves	200 Ω	150 Ω	150 Ω	100 Ω		
up to 125 slaves	100 Ω	100 Ω	100 Ω			

It is possible to interpolate linearly between the values specified in the table.

### 3.8 Determining the Contact Resistances

The resistances specified in Section 3.7 Contact Resistances can be determined by three different measuring methods.

#### 3.8.1 Measuring the Individual Resistances

The values specified in Section 3.7 Contact Resistances can also be measured by detecting the resistance between the slider and the collector wire at a standing vehicle with the electrical system switched off by means of a hand multimeter. If necessary, disconnect the sliders and / or collector wires from the connected Power Rail Boosters.

The following applies for each measured resistances:

$$R_{\text{Measurement}} \leq R_{\text{Table}}$$

#### 3.8.2 Measuring the Series Resistances of Individual Double Sliders

In order to measure the contact resistances at a moving vehicle a substitute measurement across a double slider pair can be carried out:

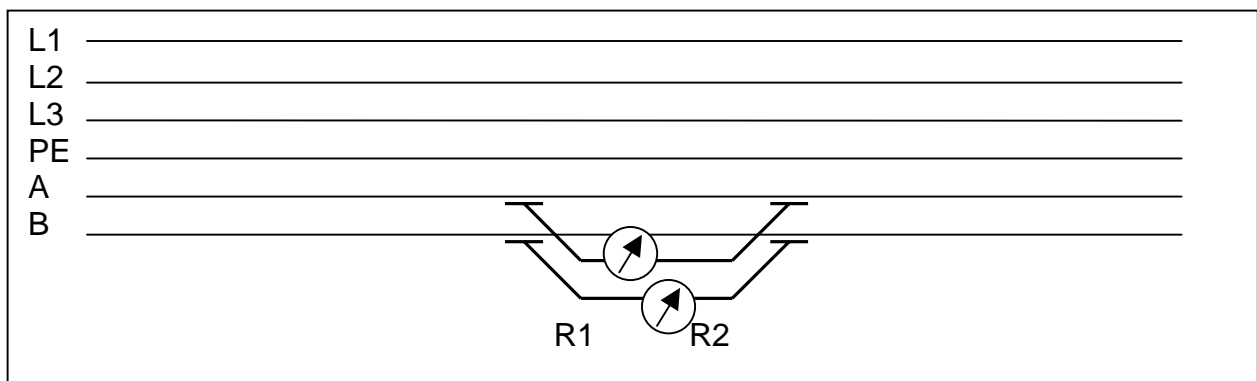

Figure 2: Measuring the contact resistances

The following applies for the resistance  $R1+R2$  measured across the two double sliders:

$$(R1+R2) / 4 \leq R_{\text{Table}}$$

### 3.8.3 Measuring the Series Resistances of Both Double Sliders

In order to measure the contact resistances at a moving vehicle the resistance can be measured across the complete series connection of the double sliders: To this purpose all the Power Rail Boosters on the measured segment have to be disconnected.

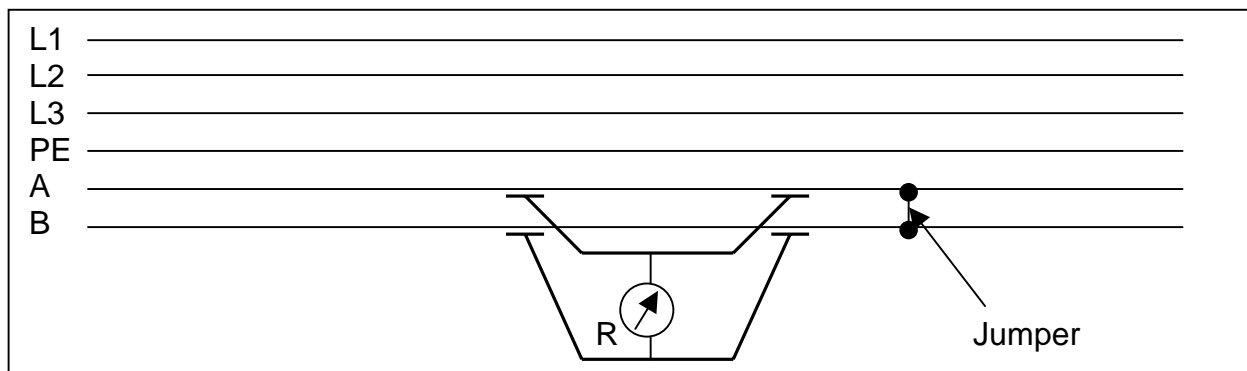

Figure 3: Measuring the contact resistances

The following applies for the resistance R measured across the two double sliders:

$$R \leq R_{\text{Table}}$$

### 3.9 Rail Cuts

PROFIBUS is a transfer system which uses an access process to the token / master-slave process. Only one station may access the transfer medium at any time. Therefore a mobile station may not cause a connection between two segments when traveling across a rail cut at which the two adjacent segment are driven by different Power Rail Boosters (segment boundary). When using electrically connected double sliders (see 3.5.1 Using Double Sliders) this can be reached, for example, by using a double rail cut (double cut) at segment boundaries instead of a single cut:

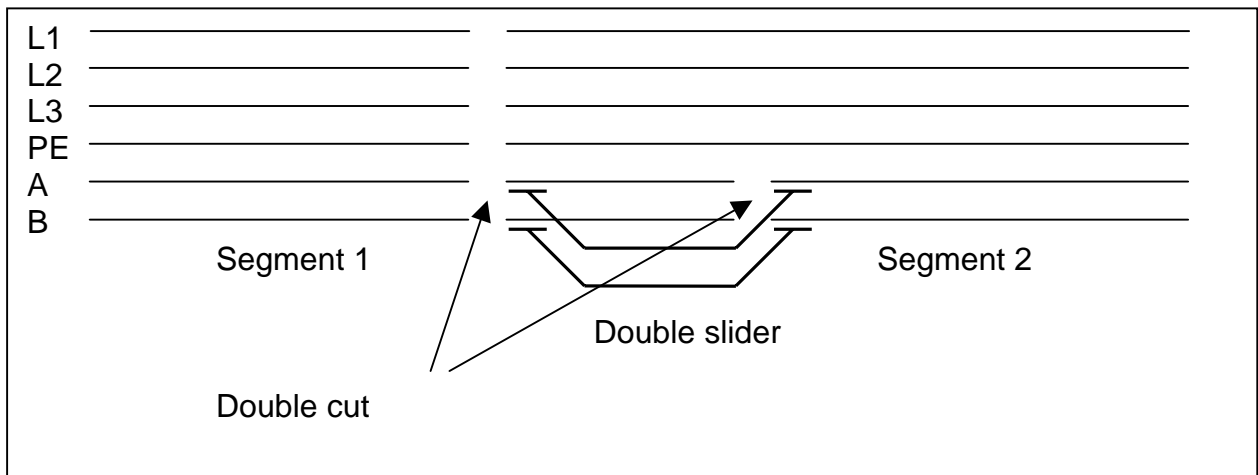

Figure 4: Double cut

Another possibility is to implement the data collector wire at the rail cut isolated across the length of the double slider (isolating cut):

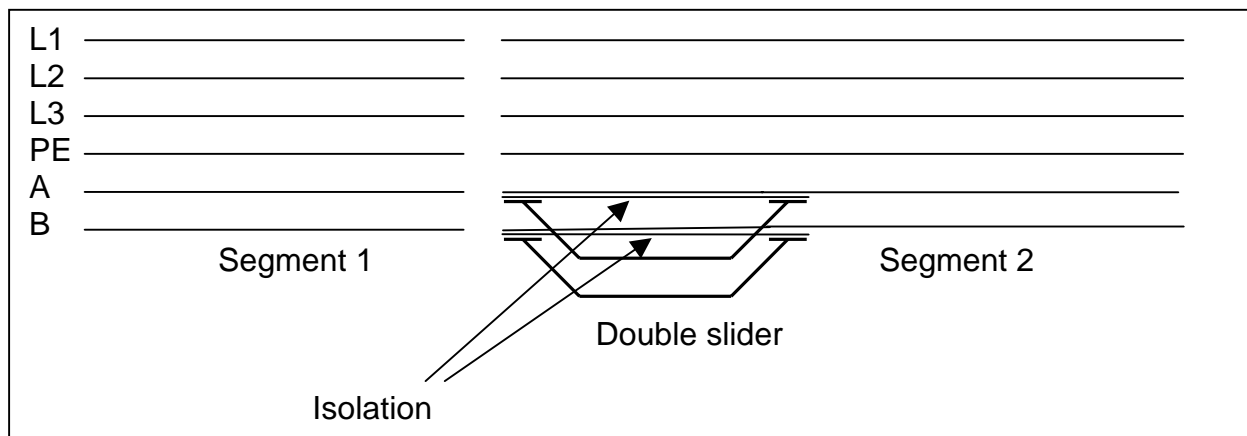

Figure 5: Isolating cut

The isolating cut can be carried out by isolating the collector wire with an appropriate insulator. In addition to the dielectric properties the mechanical properties, in particular with regard to the abrasion, have to be taken into consideration. The isolating cut can also be implemented by using an insulator instead of a wire as the collector wire.

---

#### Note

Observe the manufacturer specifications of the collector wire system used.

---



## 4 Mounting

### 4.1 Required Components

The following components are required to mount the Power Rail Booster:

- 1 x Power Rail Booster
- 1 x Connector for PROFIBUS-DP, for example:
  - FastConnect connector with 90° outgoing unit with PG socket: 6ES7 972-0BB50-0XA0
  - FastConnect connector with 90° outgoing unit without PG socket 6ES7 972-0BA50-0XA0
- PROFIBUS DP bus cable
- 1 x 24V DC supply voltage (L1+ / L2+, M1 / M2)
- 1 x grounded mounting rail 35mm
- 1 x connecting lead for conductor bar, preferably 3- or 5-core (see Figure 8: Implementing the functional ground parallel to **the data cables**)

### 4.2 Mounting Position

The preferred mounting position is horizontal mounting on a vertical wall. However, all other mounting positions are also possible under restrictions with regard to the ambient temperature.

### 4.3 Mounting Rail

The Power Rail Booster is mounted on a mounting rail conforming to EN 50022 (35 x 7.5 mm or 35 x 15 mm).

---

#### Note:

If the Power Rail Booster is subject to increased vibration and shock, it is advisable to screw the mounting rail to the fastening level at intervals of approx. 200 mm.

In order to prevent the Power Rail Booster from slipping sideways it is advisable to apply a mechanical fastening to both device ends (for example with a ground terminal 8WA2 011-1PH20).

---

## 4.4 Mounting Dimensions

The Power Rail Booster requires a mounting space of at least 120x170x135 mm (WxHxD), including a 15 mm / 7.5 mm DIN rail and the required plug-in connectors, cables as well as the required space for mounting, handling and ventilation and de-aeration.

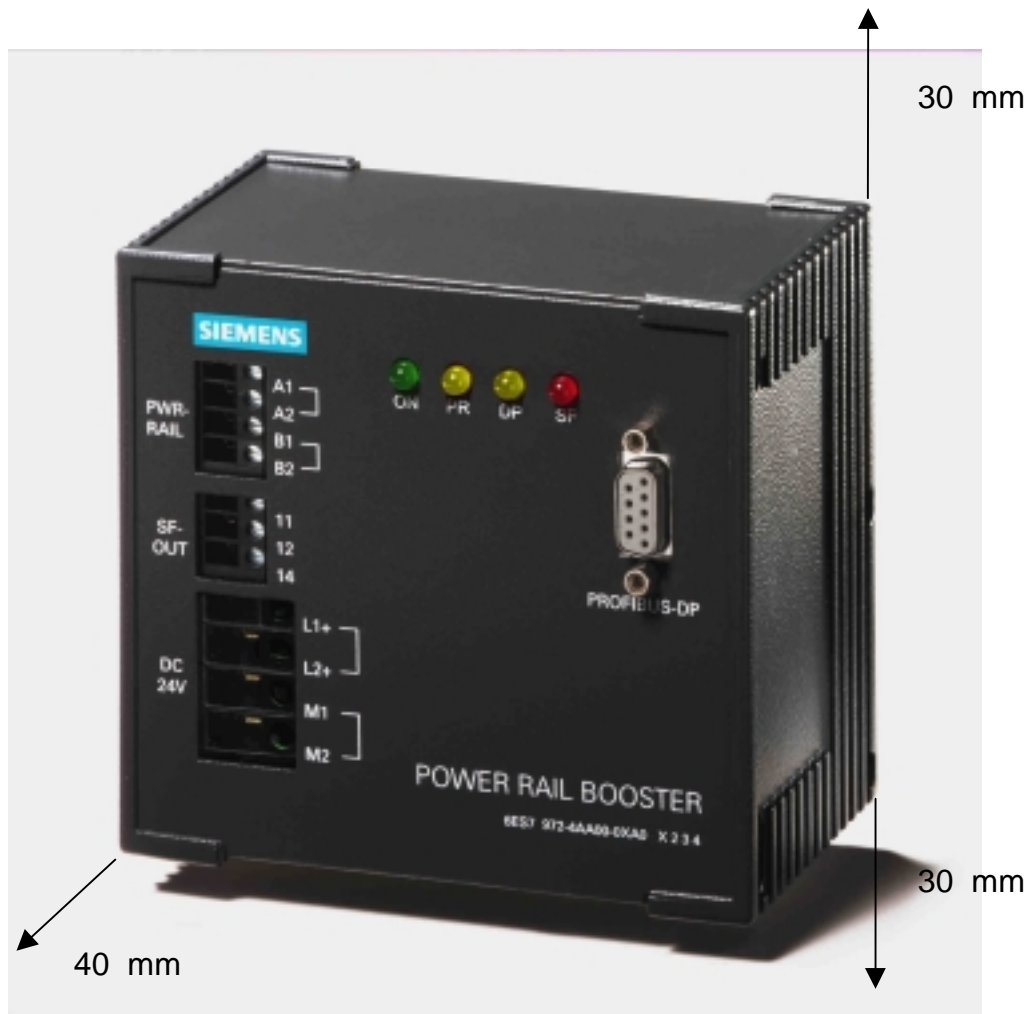

## 4.5 Required Tool

A 3 mm screwdriver is required for mounting and dismantling.

## 4.6 Mounting

1. Suspend the Power Rail Booster into the mounting rail.
2. Swivel the Power Rail Booster to the rear until the slide latches in audibly.

## 4.7 Dismantling

The Power Rail Booster is wired and ready to operate:

1. Switch off the supply voltage at the Power Rail Booster.
2. Loosen the wiring and the bus connector at the Power Rail Booster.
3. Use a screwdriver to press the slide downwards until the stop position is reached. The slider is positioned at the Power Rail Booster at the bottom rear when it is mounted vertically.
4. Swivel the Power Rail Booster out of the mounting rail while keeping the slide pressed.

# 5 Wiring

General rules and regulations on operating the Power Rail Booster

## 5.1 Introduction

As part of plants or systems the Power Rail Booster requires the observance of special rules, depending on the application, which you must observe in order to integrate the Power Rail Booster into a plant or a system.

In order to ensure proper operation and fault-free working of the Power Rail Booster, you must observe the following information on wiring.

## 5.2 Specific Applications

Observe the regulations on safety and accident prevention applying for specific applications, for example the guidelines of machine protection.

## 5.3 Emergency-Off Devices

Emergency-off devices complying with IEC204 (which corresponds to DIN VDE113)

must remain effective in all the operating modes of the plant or system.

## 5.4 24V DC Supply

The following table shows you what you have to observe with regard to the 24VDC supply.

With ...	Pay Attention to ...	
Buildings	Outdoor lightning protection	Provide for lightning protection measures (e.g. lightning protection elements)
24 V DC supply cables, signal cables	Indoor lightning protection	
24V DC Supply	Safe (electrical) isolation of extra-low voltage	

## 5.5 Protection against Outside Electrical Influences

The following table tells you what to do to provide protection against electrical influences or faults.

With ...	You have to ensure that ...
All the plants or systems in which the Power Rail Booster is installed	The plant or system is connected to a protective conductor for diverting electromagnetic interference.
Supply, signal and bus cables	The wiring arrangement and installation are correct.
Signal and bus cables	A cable or conductor break may not lead to an undefined state in the plant or system.

## 5.6 Operating a Power Rail Booster at a Grounded Supply

The following section provides information on the overall design of a Power Rail Booster at a grounded supply (TN-S system). The specific subjects discussed are:

- Cut-off organs, short-circuit and overload protection conforming to DIN VDE 0100 and DIN VDE 0113
- Load power supplies and load circuits

## 5.7 Definition: Grounded Supply

In the case of grounded supplies the neutral conductor of the system and the reference potential of the 24V supply of the Power Rail Booster are grounded. A simple ground fault between a de-energized cable and ground or a grounded part of the plant causes the protective devices to operate.

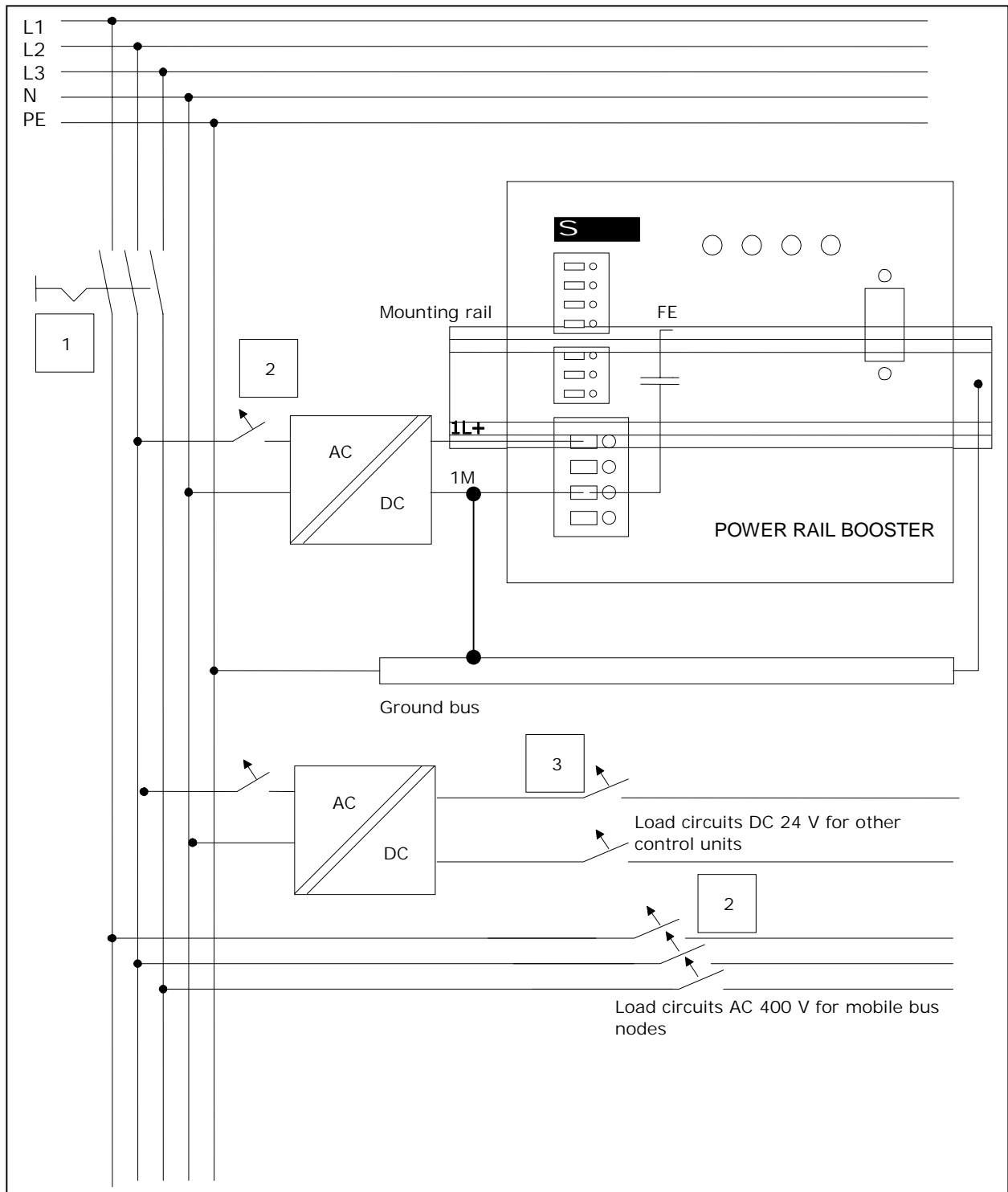

Figure 6: Operating a Power Rail Booster with grounded reference potential

## 5.9 Operating a Power Rail Booster with Ungrounded Reference Potential

The reference potential M of the nominal supply voltage of the Power Rail Booster is implemented isolated from the enclosure and connected to it by means of a capacitor with 22 nF. The parasitic ohmic leakage resistance is > 10 MOhm. This means that radio-frequency interference currents are discharged via the enclosure onto the grounded mounting rail.

## 5.10 Components and Protective Measures

Various components and protective measures are prescribed when setting up an entire plant. The type of components and the degree of mandatoriness depend on which DIN VDE regulation applies for your plant design. The following table refers to Fig. 2.

Compare ...	Reference to and	DINVDE 0100	DINVDE 0113
Circuit-breaking device for PLC, sensors and actuators	1	... Part 460: Main switch	... Part 1: Disconnecter
Short-circuit and overload protection: Grouped for sensors and actuators	2  3	... Part 725: Single-pole protection of circuits	... Part 1: <ul style="list-style-type: none"> <li>• For grounded secondary circuit: Single phase-to-ground</li> <li>• Otherwise: All-pole protection</li> </ul>
Load power supply for AC load circuits with more than five electromagnetic devices	2  3	Isolation by transformer recommended	Isolation by transformer recommended

## 5.11 Safe Electrical Isolation

Safe electrical isolation must be provided for:

- Modules which have to be supplied with voltages  $\leq 60V$  DC or  $\leq 25V$  AC respectively.
- 24V DC load circuits

## 5.12 Setting Up a Power Rail Booster with Grounded Reference Potential

When setting up the Power Rail Booster with grounded reference potential interference currents occurring are discharged onto the grounded mounting rail (functional grounding) onto which the Power Rail Booster is mounted.

## 5.13 Electrical Design of the Power Rail Booster

### Isolation Between ...

- The collector wire connections / slider and all the other circuit parts of the Power Rail Booster
- The PROFIBUS DP interface and all the other circuit parts
- The signal output SF OUT and all the other circuit parts

The following figure shows the potential relationships of the Power Rail Booster. Only the most important components are shown.

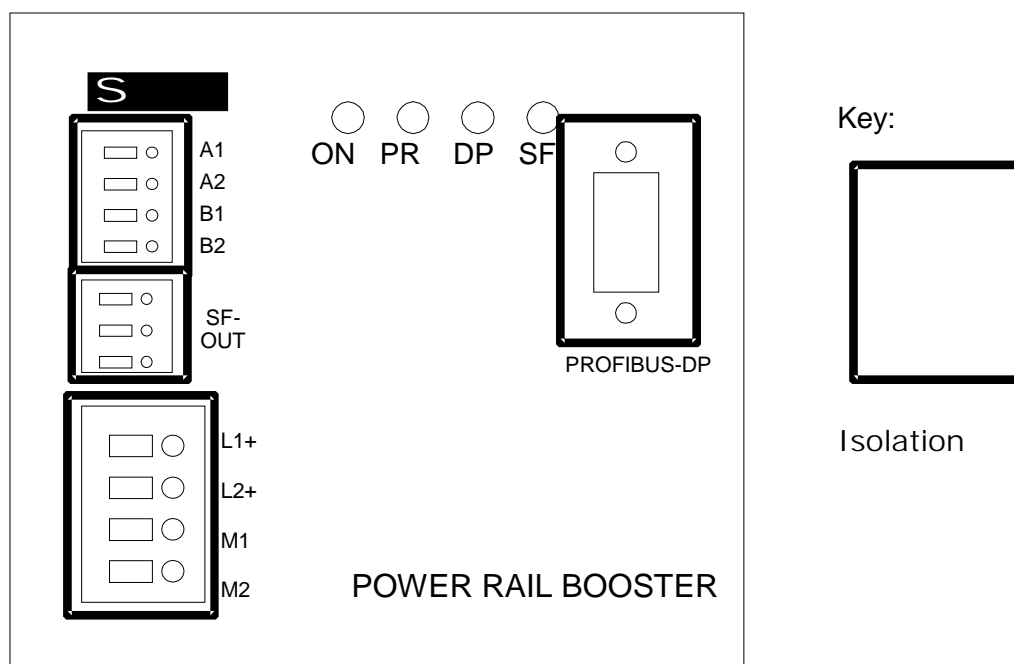

Figure 7: Potential relationships of the Power Rail Booster.

All the interfaces of the Power Rail Booster are isolated from each other. Short-circuits or faults on individual interfaces do not have an effect on the other interfaces.



## 5.14 Wiring Rules for Power Rail Booster

Wiring Rules for ...		Power 24 V DC	Power Rail A / B	SF OUT
Suitable cable		Unshielded / shielded Rigid / flexible	Unshielded / shielded Rigid / flexible	
Shield application		Not required	Not required	
Wiring arrangement		No particular requirements	Lay functional grounding parallel (e.g. additional core, applied at both ends) preferably use 3-/5-core cable. See Figure 8	No particular requirements
Connectable cable connections for solid cables		0.5 to 6 mm <sup>2</sup>	0.2 to 2.5 mm <sup>2</sup>	
Connectable cable connections for flexible cables	Without wire end ferrule	0.5 to 6 mm <sup>2</sup>	0.2 to 2.5 mm <sup>2</sup>	
	With wire end ferrule	0.5 to 4 mm <sup>2</sup>	0.2 to 1.5 mm <sup>2</sup>	
Number of cables per connection		1 or combination of 2 cables up to 2.5 mm <sup>2</sup> (sum) in a common wire end ferrule		
Maximum external diameter of the wire's insulation		∅ 5.8 mm	∅ 3.8 mm	
Stripping length of the wires		11 mm	7 mm	
Wire end ferrules to DIN 46228	Without insulating shroud	Form A, 10 to 12 mm long		
	With insulating shroud 0.25 to 1.5 mm <sup>2</sup>	Form E, 10 to 12 mm long		

## 5.15 Wiring of the Power Rail Booster

### 5.15.1 Features

- At the Power Rail Booster the individual cables are fastened in the terminal by screwing.
- No wire end ferrules required.

### 5.15.2 Prerequisites

Adhere to the wiring rules.

### 5.15.3 Required Tool

3 mm screwdriver

### 5.15.4 Wiring of the Power Rail Booster

1. Strip 11 mm of the cables
2. Insert the individual cables into the terminal
3. Screw the ends of the cables to the Power Rail Booster

### 5.15.5 Data Cables

Observe 5.14 Wiring Rules for Power Rail Booster.

When connecting the Power Rail Booster ensure that the A- and B-rails are assigned correctly to the connections.

When connecting stationary devices the simple connection to the conductor bar is sufficient. Mobile devices must always be connected via double sliders to the conductor bars. The connection of the two sliders within the double slider can be carried out directly at the slider or via the internal jumpering in the Power Rail Booster. The connection has to be implemented correspondingly with 2 or 4 cables.

---

#### Note

When assigning the signals to the individual conductor bars ensure that there is a bar with protective ground or functional ground between the power rails (L1, L2, L3, N) and the data rails (Power Rail A/B) so that influences between the various rails can be excluded to a great extent.

Please also observe Section 5.15.6 Functional Ground

and

the permissible cable lengths, as described in 3.3 Permissible Cable Length.

---

### 5.15.6 Functional Ground

Connect the DIN rail under low-inductance to the functional ground (PE rail).

If a separate conductor is used within the cable in order to lay the functional ground parallel to the bus signals PWR RAIL A / B, this can be applied at the device to a grounding terminal which is mounted next to the Power Rail Booster on the mounting rail. Also refer to **Figure 8: Implementing the functional ground parallel to the data cables**

The functional ground can be connected at the rail directly to the protective conductor - collector wire or the slider.

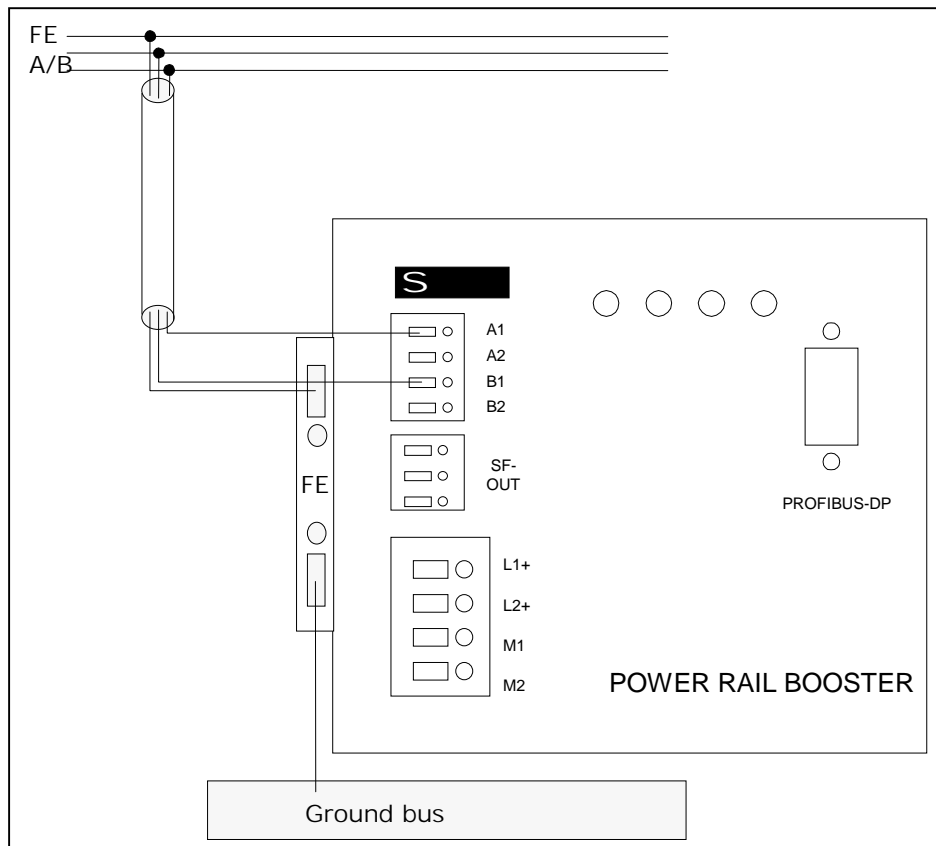

Figure 8: Implementing the functional ground parallel to the data cables

### 5.15.7 Supply Voltage

1. Strip the cables for the supply voltage of the Power Rail Booster
2. Tighten the individual wires in the screw type terminal.

### 5.15.8 PROFIBUS DP

1. Plug the bus connector onto the PROFIBUS DP connection.
2. Tighten the fixing screws of the bus connector.

---

#### Note

Only use the specified connector for the connection to the PROFIBUS DP (see Section 4.1 Required Components). These connectors ensure fault-free grounding of the shielding. In addition the shield of the bus cable has to be clamped to a shielded terminal and grounded on a large surface immediately after entry in the control cabinet or control box. Also observe the relevant design guidelines for PROFIBUS DP.

---

### 5.15.9 Signaling Contact (Optional)

Connect the binary output SF OUT to an input of the automation device or a periphery (I/O) module. The output can be operated either as an NC contact (Terminals 12-11 open at a fault) or NO contact (Terminals 11-14 close at a fault).

The potential-free signaling contact can alternatively be used to control a load (for example a signaling light).

## 6 Commissioning and Starting Up the Power Rail Booster

### 6.1 Planning Information

The PROFIBUS network parameter "Slot time" has to be adapted to the network extent, the network topology as well as the data rate due to message delays by cables and network components as well as due to monitoring mechanisms in the network components.

Planning and configuring of the PROFIBUS network is carried out with SIMATIC STEP 7 (from V4.02) or COM PROFIBUS (from V3.0). The number of OLM's and the overall cable lengths can be entered there via an input mask.

The Power Rail Booster causes a delay of 6 tbit (12  $\mu$ s at 500 kbits/s) per conversion and is to be treated as an OLM (Optical Link Module) during the configuration. Since 2 Power Rail Boosters are always connected in series, two OLM's always have to be taken in consideration for a transmission link via Power Rail Booster. The configuration tools check whether the slot time can be retained in the selected communication profile. If it is exceeded due to additional runtimes of the OLM and fiber-optic cables, a warning message appears and the parameters are adapted.

---

#### Note

A transmission link between two bus nodes may not contain any repeated conversions of PROFIBUS - DP (RS485) to Power Rail Booster (**6 tbit**) as well as in order to increase the operating safety.

---

### 6.2 Operation at Adjustable Bus Timing

The Power Rail Booster can be operated outside the bus timings specified for PROFIBUS– DP and PROFIBUS – FMS. In the process the timings must remain within the following limits:

Parameter	Minimum	Maximum
Minimum slave response time min. TSDR	11 tbits	–
Maximum bus rest period slot time	–	8000 tbits
Minimum bus rest period	11 tbits	–

## 6.3 Software Requirements

### Software Requirements for Commissioning

Configuration Software Used	Version	Notes
STEP 7	As of Version 4.02	You have included two OLM's in the configuration.
COM PROFIBUS	As of Version 3.0	You have included two OLM's in the configuration.
Configuration software for the other master used		You have set the PROFIBUS network parameter "Slot time" in accordance with the requirements of the application.

## 6.4 Requirements for Commissioning

### Requirements for Commissioning the Power Rail Booster

Required Activity	See ...
1. Power Rail Booster mounted	4 Mounting
2. Power Rail Booster wired	5 Wiring
3. Power Rail Booster configured (number of OLM's or the PROFIBUS network parameter "Slot time")	6.1 Planning Information
4. Supply voltage for the DP master switched on	Manual for DP master
5. DP master switched in the RUN operating mode	Manual for DP master

## 6.5 Taking the Power Rail Booster into Operation

Steps for taking the Power Rail Booster into operation

Step	Procedure
1.	Switch on the supply voltage for the Power Rail Booster.
2.	If necessary, switch on the supply voltage for the other plant components.

## 6.6 Starting Up the Power Rail Booster

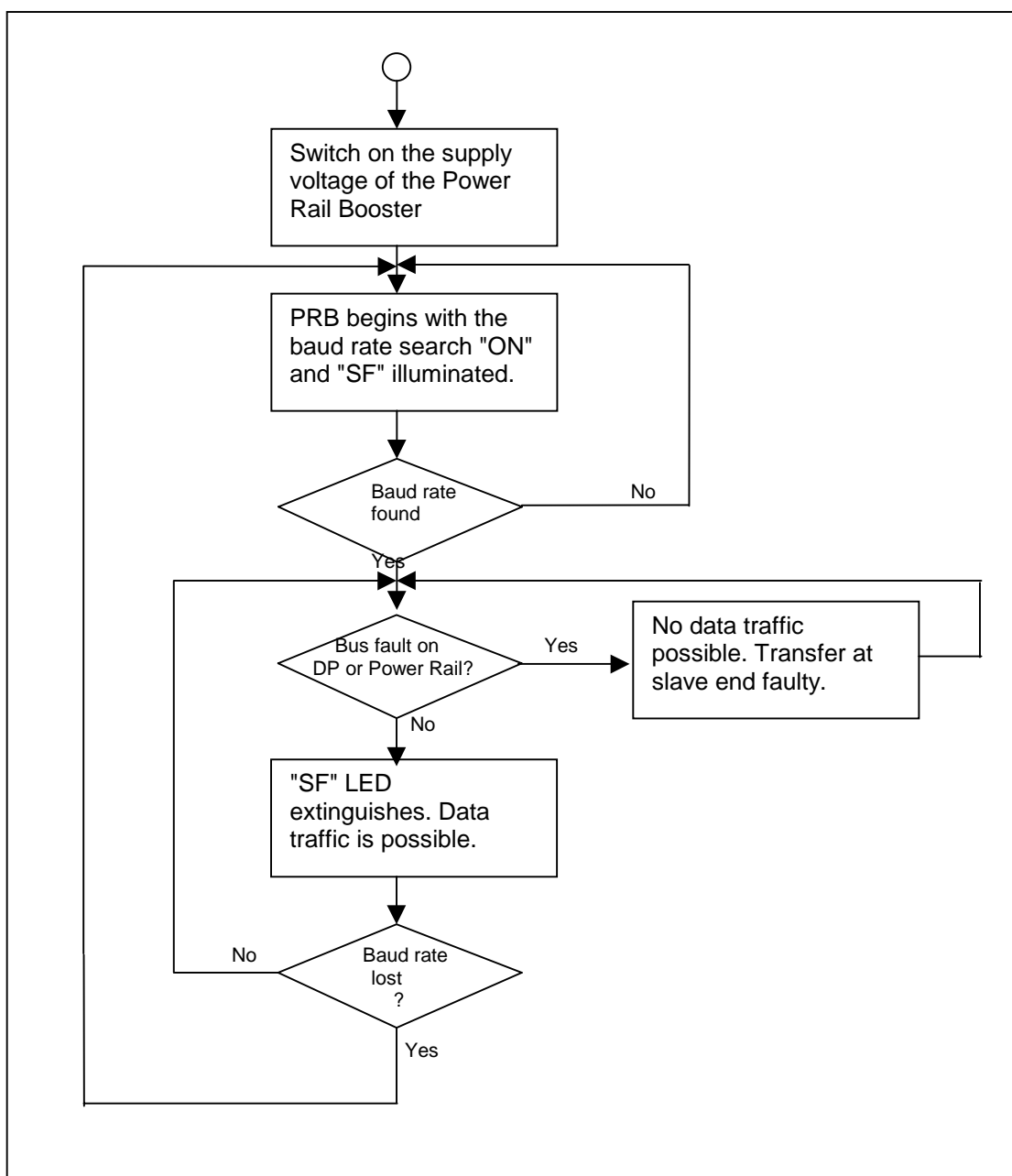

Figure 9: Starting up the Power Rail Booster

## 6.7 Status and Fault Displays through LEDs

The light emitting diodes on the front of the Power Rail Booster have the following meaning:

LED				Meaning	Remedy
ON	PR	DP	SF		
Green	Orange	Orange	Red		
Off	Off	Off	Off	There is no auxiliary supply at the Power Rail Booster.	Switch on the auxiliary supply for the Power Rail Booster.
On	*	*	*	The auxiliary supply is switched on at the Power Rail Booster	
On	Off	Off	On	Baud rate search is running	Wait until the Power Rail Booster has found the baud rate. Check whether an active master is connected to the Power Rail Booster. Ensure that the wiring between the master and the Power Rail Booster is free of faults.
On	Flickers / On	Off	Off	Messages arrive at the Power Rail interface. The master is connected to the Power Rail. No slave responds.	Check whether a slave is connected and whether its auxiliary voltage is switched on.
On	Flickers / On	Flickers / On	Off	Messages arrive at the Power Rail and DP.	
On	*	Flickers / On	Off	Messages arrive at the DP interface. The master is connected to the DP. No slave responds.	Check whether a slave is connected and whether its auxiliary voltage is switched on.
On	Flickers / On	Off	On	Messages arrive at the Power Rail interface. A fault was recognized at the DP interface.	Check the wiring of the DP interface.
On	Off	Flickers / On	On	Messages arrive at the DP interface. A fault was recognized at the Power Rail interface.	Check the wiring of the Power Rail interface. Also observe 3. Information on the Selection and Dimensioning of the Collector Wires and Sliders.

## 6.8 Status and Fault Display Through Message Output SF OUT

The group fault information (see 6.7 Status and Fault Displays through LEDs) is implemented additionally to the message output SF OUT in addition to the display via LED. Circuiting can be used to specify whether the output is to be operated as an NO contact, NC contact or changeover contact.

The contact assignment is shown schematically on the enclosure front.



## 7 General Technical Specifications

### 7.1 What Are General Technical Specifications?

The general technical specifications contain the standards and test values which the Power Rail Booster fulfills as well as the test criteria for the Power Rail Booster.

### 7.2 Standards and Approvals

#### 7.2.1 Introduction

This chapter contains the following for the Power Rail Booster:

- The most important standards whose criteria are fulfilled by the Power Rail Booster
- Approvals for the Power Rail Booster

#### 7.2.2 PROFIBUS Standard

The Power Rail Booster is based on the standard EN 50170, Volume II PROFIBUS.

#### 7.2.3 CE Approval

Our products fulfill the requirements and protective aims of the following EU guidelines and conform to the harmonized European Standards (EN) which were published for programmable logic controllers in the gazettes of the European Union:

- 89/336/EEC "Electromagnetic compatibility (EMC guideline)
- 73/23/EEC "Electrical Equipment for Use within Fixed Voltage Ranges" (Low-Voltage Directive)

The EC declarations of conformity are being kept available for the responsible authorities at:

Siemens Aktiengesellschaft  
Industrial Solutions and Services Division  
I&S IS STG 3  
Siemensstraße 33  
D- 71254 Ditzingen

### 7.2.3.1 Area of Application

The interface modules are designed for industrial use and fulfill the following requirements:

Area of application	Requirements for	
	Emitted interference	Noise Immunity
Industry	EN 50081-2 : 1993	EN 61000-6-2 : 2000

The device can also be used with an individual approval in living areas (living, business and trade, small businesses):

Area of application	Requirements for	
	Emitted interference	Noise Immunity
Living area	Individual approval required	EN 50082-1 : 1992

The individual approval has to be obtained at an authority or testing agency. In Germany the approval is given by the "Bundesamt für Post und Telekommunikation" and its agencies.

## **7.2.4 Information for the Manufacturers of Machines**

### 7.2.4.1 General

The Power Rail Booster does not represent a machine in the sense of the "Machine" EU directive. The interface therefore does not have a declaration of conformity for the EU directive "Machines" 89/392/EEC.

### 7.2.4.2 EU directive "Machines" 89/392/EEC

The EU guideline "Machines" 89/392/EEC specifies the requirements for a machine. A machine is understood to be an entity of connected parts or devices (also refer to EN292-1, Section 3.1).

The Power Rail Booster is a part of the electrical equipment of a machine and must therefore be included by the machine manufacturer in the process of obtaining the declaration of conformity.

## **7.2.5 UL Approval (Application Submitted)**

UL-Recognition-Mark  
Underwriters Laboratories (UL) to

- Standard UL 508,

## 7.2.6 CSA Approval (Application Submitted)

CSA-Certification-Mark

Canadian Standard Association (CSA) to

- Standard C22.2 No. 142,

## 7.3 Electromagnetic Compatibility

### 7.3.1 Definition

Electromagnetic compatibility is the capability of an electrical device to function satisfactorily in its electromagnetic environment without interfering with this environment.

The Power Rail Booster also fulfills the requirements of the EMC legislation of the European Union. Prerequisite is that the Power Rail Booster corresponds to the specifications and guidelines for electrical design.

### 7.3.2 Pulse-shaped Interferences

The following table shows the electromagnetic compatibility of the Power Rail Booster for pulse-shaped interferences.

Pulse-shaped interference	Tested with	Corresponds to Severity
Electrostatic discharging to IEC 801-2 (DIN VDE 0843 Part 2)	8 kV 4 kV	3 (air discharge) 2 (contact discharge)
Burst-impulse (rapid transient interferences) to IEC 801-4 (DIN VDE 0843 Part 4)	2 kV (supply cable) 2 kV (signal cable)	3 3*
High-energy single pulse (surge) to IEC 801-5 (DIN VDE 0839 Part 10) Only with lightning protection elements (see manual for DP master and description SIMATIC NET PROFIBUS networks)		
<ul style="list-style-type: none"> <li>• Asymmetric coupling</li> <li>• Symmetric coupling</li> </ul>	2 kV (supply cable) 2kV (signal line/data line)  1 kV (supply line) 1kV (signal line/data line)	3

\*Under failure criterion B a message repetition is regarded as permitted

### 7.3.3 Sinusoidal Interferences

The following table shows the electromagnetic compatibility of the Power Rail Booster for sinusoidal interferences.

RF irradiation to ENV 50140 (corresponding to IEC 801-3) Electromagnetic RF field		RF interference to ENV 50141 (corresponds to IEC 801-5)
Amplitude-modulated	Pulse-modulated	
80 MHz to 1000MHz	900 MHz $\pm$ 5 MHz	0.15 MHz to 80MHz
10 V/m		10Vrms unmodulated
80% AM (1 kHz)	50% ED	80 % AM 1 kHz)
	200 repetition frequency	150 $\Omega$ source impedance

### 7.3.4 Emission of Radio Interferences

Emitted interference of electromagnetic fields to EN 55011: Limit class A, Group 1 (measured at 10 m distance).

Frequency	Emitted Interference
From 30 MHz to 230MHz	< 40 dB ( $\mu$ V/m) Q
From 230 to 1000 MHz	< 47 dB ( $\mu$ V/m) Q

## 7.4 Transportation and Storage Conditions

The Power Rail Booster exceeds the requirements of IEC 1131, Part 2 with regard to the transportation and storage conditions. The following specifications apply to modules shipped or stored in their original packaging.

Type of Condition	Permitted Range
Free fall	$\leq$ 1 m
Temperature	From $-40^{\circ}\text{C}$ to $+70^{\circ}\text{C}$
Temperature variation	20K/h
Air pressure	From 1080 to 660 hPa (corresponds to a height of $-1000$ to $3500$ m)
Relative humidity	From 5% to 95%, without condensation

## 7.5 Climatic Ambient Conditions

The following climatic environmental conditions apply:

Ambient conditions	Range of application	Remarks
Temperature	From 0 to 60 °C	For horizontal installation
	From 0 to 40 °C	For all other mounting positions
Temperature variation	10K/h	
Relative humidity	From 15% to maximum 95%	Without condensation
Air pressure	From 1080 to 795 hPa	Corresponds to a height of -1000 to 2000m
Pollutant concentration	SO <sub>2</sub> : < ppm; Rel. humidity < 60%, no moisture condensation H <sub>2</sub> S: <0.1ppm; Rel. humidity<60%, no moisture condensation	Test: 10ppm; 4days  1 ppm; 4 days

## 7.6 Mechanical Ambient Conditions

The mechanical environmental conditions are shown in the following table in the form of sinusoidal oscillations.

Frequency Range	Limit
$10 \leq f \leq 58 \text{ Hz}$	0.15mm amplitude
$58 \leq f \leq 150 \text{ Hz}$	0.5 g constant acceleration

## 7.6.1 Tests for Mechanical Ambient Conditions

The following table provides information on the type and extent of tests of mechanical environmental conditions.

Test for ...	Test standard	Terminal Modules and Electronic Modules
Oscillations	Oscillation test to IEC 68 Part 2-6 (sine)	Oscillation type: Frequency sweeps with a sweep rate of 1 octave/minute. $10 \text{ Hz} \leq f \leq 58 \text{ Hz}$ , constant amplitude 0.15 mm $58 \text{ Hz} \leq f \leq 150 \text{ Hz}$ , constant acceleration 2 g Oscillation time: 20 frequency sweeps per axis on each of the three axes perpendicular to each other
Shock	Shock, tested to IEC 68 Part 2-29	Type of shock: half sine Force of shock: 15 g peak value, 11 ms duration Direction of shock: 3 shocks each in +/- direction in of the three vertical axes.
Endurance bump	Shock test to IEC 68 Part 2-29	Type of shock: half sine Force of shock: 25 g peak value, 6 ms duration Direction of shock: 3 shocks each in +/- direction in of the three vertical axes.

## 7.7 Information on Insulation Testing, Safety Class, Degree of Protection, and Rated Voltage of the Power Rail Booster

### 7.7.1 Test Voltage

Insulation strength is demonstrated in the routine test with the following test voltage in accordance with IEC 1131, Part 2:

Circuits with nominal voltage $U_e$ against other circuits or to grounding	Test Voltage
$0 \text{ V} < U_e \leq 50 \text{ V}$	500 V DC
$50 \text{ V} < U_e \leq 300 \text{ V}$	$2 \times U_{\text{rated}} + 1000 \text{ V}$
$300 \text{ V} < U_e \leq 600 \text{ V}$	-

### 7.7.2 Pollution Severity/Overvoltage Category

- Pollution severity 2 in accordance with IEC 60664 (IEC 1131)
- Overvoltage category to IEC 60664
  - at  $U_N = \text{AC } 120/230 \text{ V}$ : III (signaling contact)
  - at  $U_N = \text{DC } 24 \text{ V}$ : II (everything except signaling contact)

### 7.7.3 Safety Class

Protection class 2 in accordance with IEC 536 (DIN VDE 0106, Part 1)

### 7.7.4 Degree of Protection

Degree of protection IP 20 to IEC 529

- Protection against contact with standard test probes
- Protection against foreign bodies with a diameter greater than 12.5 mm
- No special protection against water

### 7.7.5 Electrical Connection Data

The Power Rail Booster operates with the connection data contained in the following table and with the corresponding tolerances.

	Rated value	Tolerance range / Note
Auxiliary voltage	24 V DC	20.4 to 28.8V DC
Power input	Up to 20 W	Depending on the transfer speed and the number of bus nodes
Starting current inrush	Up to 20A	With a duration < 1 ms
Recommended fusing	6A, cutoff characteristics B/C	
Discharge impedance against functional ground	>1 Mohm	+/- 10%

### 7.7.6 Electrical Connection Data of the Signaling Contact

Contact data	Upper limit
Continuous current	6 A
Switching voltage	230 V
Switching capacity	150 W
Contact resistance	100 mOhm

## 7.8 Connections

### 7.8.1 Pin Assignment of the RS485 Interface (PROFIBUS DP)

Pin – No.	Name	Function
1	n. c.	Reserved
2	n. c.	Reserved
3	RxD / TxD – P	Data line B



4	RTS	Request To Send
5	M5V	Data reference potential (from node)
6	P5V	Supply plus (from node)
7	n. c.	Reserved
8	RxD/TxD-N	Data line A
9	n. c.	Reserved

### 7.8.2 Terminal Assignment of the Power Supply (24 V DC)

PIN NO.	Name	Function
1,2	L1+ / L2+	24 V DC
3,4	M1 / M2	Ground

### 7.8.3 Terminal Assignment of the Power Rail Interface (Power Rail)

Pin No.	Name	Function
1	A1	Conductor bar A, first slider
2	A2	Conductor bar A, second slider
3	B1	Conductor bar B, first slider
4	B2	Conductor bar B, second slider

### 7.8.4 Pin Assignment of the Signaling Contact (SF OUT)

Pin No.	Name	Function
1	11	Common connection
2	12	NC contact
3	14	NO contact

## 7.9 Interfaces

Type	Number	Function information
PROFIBUS – DP	1	9600 to 500000 bits/s
Power Rail	1	9600 to 500000 bits/s
Signaling contact	1	NC or NO contact

## 7.10 Order Number

Device	Function information
Power Rail Booster	6ES7 972-4AA00-0XA0

## 8 Constantly Updated Information

You can obtain constantly updated information on SIMATIC products on the Internet at <http://www.ad.siemens.de/>

In addition, SIMATIC Customer Support provides you with up-to-date information and downloads that can be useful to you when using SIMATIC products:

On the Internet at [http://www.ad.siemens.de/support/html\\_00/index.shtml](http://www.ad.siemens.de/support/html_00/index.shtml)

Via the SIMATIC Customer Support mailbox at +49(911)895-7100

To dial the mailbox, use a modem capable of up to V.34 (28.8kbps) and set its parameters as follows: 8, N, 1, ANSI. Alternatively, dial in using ISDN (x.75, 64 kbps).

You can contact SIMATIC Customer Support by phone at +49(911)895-7000 or by fax at +49(911)895-7002. You can send questions by e-mail on the Internet or to the above-mentioned mailbox.

## 9 Glossary

### **Automation System**

An automation system is a programmable logic controller which consists of at least a CPU, various input and output modules as well as operator control and monitoring devices.

### **Baud rate**

The baud rate of a data transfer is measured in bits transmitted per second. At the Power Rail Booster baud rates of 9,6 kbauds to 500 kbauds are possible.

### **Reference Potential**

Potential from which the voltages of the circuits involved can be observed and/or measured.

### **Bus**

A common transfer route connecting all nodes and having two defined ends. At a Power Rail Booster the bus is a two-wire cable or a pair of collector wires.

### **Bus Connector**

A physical connection between the bus nodes and the bus line.

### **Distributed I/O devices**

Are input/output devices which are not used in the central unit, but are set up distributed at a large distance from the CPU, for example:

- \_ ET 200M, ET 200B, ET 200X, ET 200L, ET 200S
- \_ DP/AS-I link
- \_ S5-95U with PROFIBUS DP slave interface
- \_ Further DP slaves of Siemens or other manufacturers

The distributed I/O devices are connected via PROFIBUS DP to the DP master.

### **Double slider**

Arrangement of two sliders, usually borne mechanically independently, through which a contact with high contact stability is established together.

### **Double Cut**

Rail cut which is implemented double in order to avoid short circuits between two collector wire segments which can occur via a (double) slider when traveling over a rail cut.

### **DP**

Distributed Peripheral (I/O) device

### **DP Master**

A master which behaves in accordance with the standard EN 50170, Volume 2, PROFIBUS is called a DP master.

**DP Standard**

DP standard is the bus protocol which can be transferred via the Power Rail Booster in accordance with the standard EN 50170, Volume 2, PROFIBUS.

**DP Slave**

A slave which is operated at the PROFIBUS with the PROFIBUS DP protocol and behaves in accordance with the standard EN 50170, Volume 2, PROFIBUS is called a DP slave.

**Ground**

The conductive mass of earth, the electrical potential of which is equivalent to zero. In the vicinity of grounding electrodes, the potential may not be zero. The term "reference ground" is often used for this state.

**Grounding**

Grounding means that a conducting part is connected via a grounding unit to the grounding electrode.

**Isolating Cut**

Rail cut in which the data collector wire is isolated for the length of a double slider in order to avoid short circuits between two collector wire segments which can occur via a (double) slider while traveling across a rail cut.

**Fiber-optic cable**

Fiber-optic cable

**Ground**

The ground is the total of all inactive parts of a device connected to each other which cannot be subject to dangerous touch voltage even if a fault occurs.

**Master**

When it has a token, a master can send data to and request data from other nodes (active nodes). DP masters are, for example, the CPU 315-2 DP or the IM 308-C.

**OLM**

Optical Link Module

**PELF**

Protective Extra Low Voltage = Functional extra-low voltage with protective separation

**Equipotential bonding**

Electrical connection (equipotential bonding conductor) that brings the exposed conductive parts of electrical equipment and other conductive parts to the same or approximately the same potential in order to prevent troublesome or dangerous voltages arising between these parts.

**Non-floating**

In the case of non-floating input/output modules the reference potentials of the control and load circuits are connected electrically.

**Isolated**

In the case of isolated input/output modules the reference potentials of control and load circuits are separated metallicity, for example by optocouplers, relay contacts or transformer. Input/output circuits can be connected to common potential.

**Power Rail Booster**

Booster for PROFIBUS. For transferring the bus signal via collector wire.

**PR**

Power Rail

**Bouncing**

Single or repeated, random or reproducible disengaging or re-engaging of a slider from or onto the collector wire respectively.

**PROFIBUS DP**

PROcess Field BUS, German process and field bus standard which is specified in EN 50170, Volume 2, PROFIBUS. It defines the functional, electrical, and mechanical properties of a bit-serial field bus system.

PROFIBUS is available with the protocols DP (= Distributed Peripheral), FMS (= Field bus Message Specification), PA (= Process Automation) or TF (= Technological Function).

**PROFIBUS Address**

Every bus node must have a PROFIBUS address assigned to it in order to allow unique identification at the PROFIBUS.

PC's/Programming devices have the PROFIBUS address "0".

**Slider**

Mobile part of the collector wire system.

**Collector Wire**

Fixed part of the collector wire system, also called the conductor bar.

**Collector Wire System**

A collector wire system consists of sliders and collector wires. The collector wire system can be used to transfer power and data, whereby the collector wire system ensures the mobile contacting between fixed and mobile parts.

**Segment**

The bus line between two terminating resistors forms a segment. A PROFIBUS DP segment contains 0 to 32 bus nodes. Segments can be coupled via RS 485 Repeaters.

All the collector wires with conductive connective for a collector wire segment. Up to 124 bus nodes can be operated at a collector wire segment. Segments can be coupled via RS 485.

**Self-cleaning**

Cleaning of the collector wire and the slider caused by the operation of the collector wire system. The movement of the sliders on the collector wire pushes dust particles away and abrades oxide layers. The effect of self-cleaning increases the more a

collector wire is traveled over and the greater the pressure of the slider on the collector wire.

**SELF**

Safety Extra Low Voltage

**SF**

Group error

**Slave**

A slave may only exchange data with a master after it has been prompted by the master to do so. Slaves are, for example, all the DP slaves such as ET 200L, ET 200X, ET 200M, ET 200S, etc.

**tbit**

Bit duration, length of a bit

**Contact Resistance**

Electrical resistance at the transition from a collector wire to a slider. The transition resistance depends on the soiling of the sliders and collector wires as well as the oxidation of their surfaces.

## 10 Directory of Figures

Figure 1: Application example .....	9
Figure 2: Measuring the contact resistances .....	13
Figure 3: Measuring the contact resistances .....	14
Figure 4: Double cut .....	15
Figure 5: Isolating cut .....	16
Figure 6: Operating a Power Rail Booster with grounded reference potential.....	21
Figure 7: Potential relationships of the Power Rail Booster.....	24
Figure 8: Implementing the functional ground parallel to the data cables .....	27
Figure 9: Starting up the Power Rail Booster .....	31