

# SIEMENS

## SIMATIC

### S7-300 CPU 31xC and CPU 31x: Installation

#### Operating Instructions

Preface	
Guide to the S7-300 documentation	1
Installation Order	2
S7-300 components	3
Configuring	4
Installing	5
Wiring	6
Addressing	7
Commissioning	8
Maintenance	9
Debugging functions, diagnostics and troubleshooting	10
General technical data	11
Appendix	A

This manual is part of the documentation package with the order number:  
6ES7398-8FA10-8BA0

## Legal information

### Warning notice system

This manual contains notices you have to observe in order to ensure your personal safety, as well as to prevent damage to property. The notices referring to your personal safety are highlighted in the manual by a safety alert symbol, notices referring only to property damage have no safety alert symbol. These notices shown below are graded according to the degree of danger.

<b>⚠ DANGER</b>
indicates that death or severe personal injury <b>will</b> result if proper precautions are not taken.
<b>⚠ WARNING</b>
indicates that death or severe personal injury <b>may</b> result if proper precautions are not taken.
<b>⚠ CAUTION</b>
with a safety alert symbol, indicates that minor personal injury can result if proper precautions are not taken.
<b>CAUTION</b>
without a safety alert symbol, indicates that property damage can result if proper precautions are not taken.
<b>NOTICE</b>
indicates that an unintended result or situation can occur if the corresponding information is not taken into account.

If more than one degree of danger is present, the warning notice representing the highest degree of danger will be used. A notice warning of injury to persons with a safety alert symbol may also include a warning relating to property damage.

### Qualified Personnel

The device/system may only be set up and used in conjunction with this documentation. Commissioning and operation of a device/system may only be performed by **qualified personnel**. Within the context of the safety notes in this documentation qualified persons are defined as persons who are authorized to commission, ground and label devices, systems and circuits in accordance with established safety practices and standards.

### Prescribed Usage

Note the following:

<b>⚠ WARNING</b>
This device may only be used for the applications described in the catalog or the technical description and only in connection with devices or components from other manufacturers which have been approved or recommended by Siemens. Correct, reliable operation of the product requires proper transport, storage, positioning and assembly as well as careful operation and maintenance.

### Trademarks

All names identified by ® are registered trademarks of the Siemens AG. The remaining trademarks in this publication may be trademarks whose use by third parties for their own purposes could violate the rights of the owner.

### Disclaimer of Liability

We have reviewed the contents of this publication to ensure consistency with the hardware and software described. Since variance cannot be precluded entirely, we cannot guarantee full consistency. However, the information in this publication is reviewed regularly and any necessary corrections are included in subsequent editions.

# Preface

## Purpose of this manual

This manual contains essential information about:

- the configuration,
- the installation
- the wiring
- the addressing
- and commissioning

In addition, you will become familiar with the tools you can use to diagnose and eliminate errors in hardware and software.

## Basic knowledge

- To understand this manual, you require a general knowledge of automation engineering.
- You require a knowledge of STEP 7 basic software.

## Scope

Table 1 Scope of this manual

CPU	Convention: CPU designations:	Order No.	as of Version firmware
CPU 312C	CPU 31xC	6ES7312-5BE03-0AB0	V2.6
CPU 313C		6ES7313-5BF03-0AB0	V2.6
CPU 313C-2 PtP		6ES7313-6BF03-0AB0	V2.6
CPU 313C-2 DP		6ES7313-6CF03-0AB0	V2.6
CPU 314C-2 PtP		6ES7314-6BG03-0AB0	V2.6
CPU 314C-2 DP		6ES7314-6CG03-0AB0	V2.6
CPU 312		CPU 31x	6ES7312-1AE13-0AB0
CPU 314	6ES7314-1AG13-0AB0		V2.6
CPU 315-2 DP	6ES7315-2AG10-0AB0		V2.6
CPU 315-2 PN/DP	6ES7315-2EH13-0AB0		V2.6
CPU 317-2 DP	6ES7317-2AJ10-0AB0		V2.6
CPU 317-2 PN/DP	6ES7317-2EK13-0AB0		V2.6
CPU 319-3 PN/DP	6ES7318-3EL00-0AB0		V2.7

---

**Note**

The special features of the F-CPU's of the S7 spectrum can be found as product information on the Internet (<http://support.automation.siemens.com/WW/view/en/11669702/133300>).

---

**Note**

For new modules, or modules of a more recent version, we reserve the right to include a Product Information containing latest information.

---

### Changes compared to the previous version

Changes compared to the previous version of this operating instructions CPU31xC and CPU31x: Installation, Release 12/2006 (A5E00105491-07):

New properties of the CPU 319-3 PN/DP V2.7

- PROFINET IO with IRT (Isochronous Real Time) with the option "high flexibility"
- Prioritized startup for IO devices
- Replacing of PROFINET IO devices without changing the storage medium
- Changing IO devices during operation (changing partner ports)
- Increase in the OUC connection resources from previously 8 to 32
- Increase in the maximum number of simultaneously active Alarm-S blocks to 300
- CBA extensions (supporting of further data structures)
- Data set routing
- Extension of the web server functionality:
  - module state
  - topology

Firmware update via networks is possible for all CPUs.

### Standards and certifications

In Chapter *General technical data*, you will find information about standards, certificates and approvals

### Recycling and Disposal

The devices described in this manual can be recycled, because their components contain a minimum of harmful substances. For environment-friendly recycling and disposal of your old equipment, contact a certified disposal facility for electronic scrap.

# Table of contents

	<b>Preface</b> .....	<b>3</b>
<b>1</b>	<b>Guide to the S7-300 documentation</b> .....	<b>9</b>
1.1	Documentation classification .....	9
1.2	Guide to the S7-300 documentation .....	12
<b>2</b>	<b>Installation Order</b> .....	<b>15</b>
<b>3</b>	<b>S7-300 components</b> .....	<b>17</b>
3.1	Example of an S7-300 configuration.....	17
3.2	Overview of the vital modules of an S7-300 .....	17
<b>4</b>	<b>Configuring</b> .....	<b>23</b>
4.1	Overview .....	23
4.2	Basic engineering principles .....	23
4.3	Component dimensions .....	25
4.4	Specified clearances .....	27
4.5	Arrangement of modules on a single rack .....	28
4.6	Distribution of modules to several racks .....	29
4.7	Selection and installation of cabinets.....	32
4.8	Example: Selecting a cabinet.....	35
4.9	Electrical assembly, protective measures and grounding .....	36
4.9.1	Grounding concept and overall structure.....	36
4.9.2	Installing an S7-300 with grounded reference potential .....	38
4.9.3	Installing an S7-300 with ungrounded reference potential (not CPU 31xC) .....	39
4.9.4	Isolated or common potential modules? .....	40
4.9.5	Grounding measures .....	43
4.9.6	Overview display: Earthing .....	45
4.10	Selection of the load power supply .....	47
4.11	Planning subnets .....	49
4.11.1	Overview .....	49
4.11.2	Configuring MPI and PROFIBUS subnets .....	51
4.11.2.1	Overview .....	51
4.11.2.2	Basic principles of MPI and PROFIBUS subnets .....	51
4.11.2.3	Multi-Point Interface (MPI) .....	54
4.11.2.4	PROFIBUS DP interface.....	56
4.11.2.5	Network components of MPI/DP and cable lengths .....	59
4.11.2.6	Cable lengths of MPI and PROFIBUS subnets .....	64

4.11.3	Configuring PROFINET subnets.....	69
4.11.3.1	Overview .....	69
4.11.3.2	PROFINET devices.....	69
4.11.3.3	Integration of fieldbuses into PROFINET.....	73
4.11.3.4	PROFINET IO and PROFINET CBA .....	74
4.11.3.5	PROFINET cable lengths and network expansion .....	80
4.11.3.6	Connectors and other components for Ethernet.....	83
4.11.3.7	Example of a PROFINET Subnet .....	83
4.11.3.8	PROFINET IO System .....	85
4.11.4	Routed network transitions.....	86
4.11.5	Point-to-point (PtP).....	88
4.11.6	Actuator/sensor interface (ASI).....	88
<b>5</b>	<b>Installing .....</b>	<b>89</b>
5.1	Installing a S7-300 .....	89
5.2	Installing the mounting rail .....	91
5.3	Installing modules on the mounting rail.....	94
5.4	Labeling modules .....	96
<b>6</b>	<b>Wiring .....</b>	<b>99</b>
6.1	Requirements for wiring the S7-300 .....	99
6.2	Bonding the Protective Conductor to the Mounting Rail .....	101
6.3	Adjusting the Power Supply Module to Local Mains Voltage.....	102
6.4	Wiring the Power Supply Module and the CPU .....	103
6.5	Wiring front connectors .....	105
6.6	Plugging the front connectors into modules.....	108
6.7	Labeling the module I/Os .....	113
6.8	Terminating shielded cables on the shielding contact element .....	114
6.9	Wiring the MPI / PROFIBUS connectors .....	117
6.9.1	Connecting the bus connector .....	117
6.9.2	Setting the terminating resistor on the bus connector .....	118
<b>7</b>	<b>Addressing.....</b>	<b>119</b>
7.1	Slot-specific addressing of modules .....	119
7.2	User-specific addressing of modules .....	121
7.2.1	User-specific addressing of modules .....	121
7.2.2	Addressing digital modules .....	122
7.2.3	Addressing analog modules.....	124
7.2.4	Addressing the integrated I/Os of CPU 31xC .....	125
7.3	Addressing on PROFIBUS DP.....	127
7.4	Addressing on PROFINET .....	128
<b>8</b>	<b>Commissioning .....</b>	<b>129</b>
8.1	Overview .....	129
8.2	Commissioning procedure .....	129
8.2.1	Procedure: Commissioning the hardware.....	129
8.2.2	Procedure: Software commissioning .....	131
8.3	Commissioning check list.....	132

8.4	Commissioning the Modules.....	134
8.4.1	Inserting/Replacing a Micro Memory Card .....	134
8.4.2	Initial turn-on .....	136
8.4.3	CPU memory reset by means of mode selector switch.....	137
8.4.4	Formatting the Micro Memory Card .....	140
8.4.5	Connecting the programming device (PG) .....	141
8.4.5.1	Connect PG/PC to the integrated PROFINET interface of the CPU 31x PN/DP .....	141
8.4.5.2	Connecting the PG to a node.....	142
8.4.5.3	Connecting the PG to several nodes .....	143
8.4.5.4	Using the PG for commissioning or maintenance.....	144
8.4.5.5	Connecting a PG to ungrounded MPI nodes (not CPU 31xC) .....	146
8.4.6	Starting SIMATIC Manager.....	147
8.4.7	Monitoring and modifying I/Os .....	148
8.5	Commissioning PROFIBUS DP .....	152
8.5.1	Commissioning PROFIBUS DP .....	152
8.5.2	Commissioning the CPU as DP master.....	154
8.5.3	Commissioning the CPU as DP Slave.....	158
8.5.4	Direct data exchange .....	163
8.6	Commissioning PROFINET IO .....	165
8.6.1	Requirements.....	165
8.6.2	Configuring and commissioning the PROFINET IO system .....	166
<b>9</b>	<b>Maintenance .....</b>	<b>173</b>
9.1	Overview .....	173
9.2	Backing up firmware on a SIMATIC Micro Memory Card.....	173
9.3	Updating the firmware.....	174
9.3.1	Backing up firmware on a SIMATIC Micro Memory Card.....	174
9.3.2	Firmware update using a Micro Memory Card.....	175
9.3.3	Updating the firmware online (via networks).....	177
9.4	Backup of project data to a Micro Memory Card .....	178
9.5	Resetting to the Delivery State .....	180
9.6	Module installation / removal .....	182
9.7	Digital output module AC 120/230 V: Changing fuses .....	186
<b>10</b>	<b>Debugging functions, diagnostics and troubleshooting .....</b>	<b>189</b>
10.1	Overview .....	189
10.2	Identification and maintenance data of the CPU .....	189
10.3	Overview: Test functions.....	192
10.4	Overview: Diagnostics .....	194
10.5	Diagnostics functions available in STEP 7 .....	198
10.6	Network infrastructure diagnostics (SNMP).....	199
10.7	Diagnostics using status and error LEDs.....	201
10.7.1	Introduction .....	201
10.7.2	Status and error displays of all CPUs .....	201
10.7.3	Evaluating the SF LED in case of software errors .....	202
10.7.4	Evaluating the SF LED in case of hardware errors.....	204
10.7.5	Status and Error Indicators: CPUs with DP Interface .....	205
10.7.6	Status and Error Indicators: CPUs with PROFINET interface for the S7-300 .....	206
10.7.7	Status and Error Indicators: PROFINET IO Devices .....	208

10.8	Diagnostics of DP CPUs .....	209
10.8.1	Diagnostics of DP CPUs operating as DP Master .....	209
10.8.2	Reading out slave diagnostic data .....	212
10.8.3	Interrupts on the DP Master .....	217
10.8.4	Structure of the slave diagnostic data when the CPU is operated as intelligent slave .....	218
10.9	Diagnostics of PROFINET CPUs .....	226
10.9.1	Diagnostics options of PROFINET IO .....	226
10.9.2	Maintenance .....	228
<b>11</b>	<b>General technical data .....</b>	<b>229</b>
11.1	Standards and approvals .....	229
11.2	Electromagnetic compatibility .....	234
11.3	Transportation and storage conditions for modules .....	236
11.4	Mechanical and climatic environmental conditions for S7-300 operation .....	237
11.5	Specification of dielectric tests, protection class, degree of protection, and rated voltage of S7-300 .....	239
11.6	Rated voltages of S7-300 .....	239
<b>A</b>	<b>Appendix .....</b>	<b>241</b>
A.1	General rules and regulations for S7-300 operation .....	241
A.2	Protection against electromagnetic interference .....	243
A.2.1	Basic Points for EMC-compliant system installations .....	243
A.2.2	Five basic rules for securing EMC .....	245
A.2.2.1	1. Basic rule for ensuring EMC .....	245
A.2.2.2	2. Basic rule for ensuring EMC .....	245
A.2.2.3	3. Basic rule for ensuring EMC .....	246
A.2.2.4	4. Basic rule for ensuring EMC .....	246
A.2.2.5	5. Basic rule for ensuring EMC .....	247
A.2.3	EMC-compliant installation of automation systems .....	247
A.2.4	Examples of an EMC-compliant installation: Cabinet configuration .....	249
A.2.5	Examples of an EMC-compliant installation: Wall mounting .....	250
A.2.6	Cable shielding .....	252
A.2.7	Equipotential bonding .....	254
A.2.8	Cable routing inside buildings .....	256
A.2.9	Outdoor routing of cables .....	258
A.3	Lightning and surge voltage protection .....	259
A.3.1	Overview .....	259
A.3.2	Lightning protection zone concept .....	259
A.3.3	Rules for the transition point between lightning protection zones 0 <-> 1 .....	261
A.3.4	Rules for the transition point between lightning protection zones 1 <-> 2 and higher .....	262
A.3.5	Example: Surge protection circuit for networked S7-300 PLCs .....	265
A.3.6	How to protect digital output modules against inductive surge voltage .....	267
A.4	Functional safety of electronic control equipment .....	269
	<b>Glossary .....</b>	<b>271</b>
	<b>Index .....</b>	<b>299</b>



# Guide to the S7-300 documentation

## 1.1 Documentation classification

### Documentation classification

The documentation listed below is part of the S7-300 documentation package.

This is also available on the Internet at:

<http://support.automation.siemens.com/WW/view/en/> and the corresponding entry ID

Name of the manual	Description
Manual CPU 31xC and CPU 31x: <b>Technical Data</b> Article ID: 12996906	<ul style="list-style-type: none"> <li>• Operator control and display elements</li> <li>• Communication</li> <li>• Memory concept</li> <li>• Cycle and response times</li> <li>• Technical data</li> </ul>
Operating Instructions CPU 31xC and CPU 31x: <b>Installation</b> Entry ID: 13008499	<ul style="list-style-type: none"> <li>• Configuring</li> <li>• Installing</li> <li>• Wiring</li> <li>• Addressing</li> <li>• Start-up</li> <li>• Maintenance and the test functions</li> <li>• Diagnostics and troubleshooting</li> </ul>
Manual CPU 31xC: <b>Technological functions</b> incl. CD Entry ID: 12429336	Description of the specific technological functions: <ul style="list-style-type: none"> <li>• Positioning</li> <li>• Counting</li> <li>• Point-to-point connection</li> <li>• Rules</li> </ul> The CD contains examples of the technological functions.
Manual S7-300 Automation System: <b>Module data</b> Entry ID: 8859629	Functional descriptions and technical specifications of the following modules: <ul style="list-style-type: none"> <li>• Signal modules</li> <li>• Power supplies</li> <li>• Interface modules</li> </ul>

Name of the manual	Description
<p><b>Instruction List</b>                      CPU 31xC, CPU 31x,                      IM151-7 CPU, IM154-8 CPU, BM 147-1 CPU,                      BM 147-2 CPU                      Entry ID: 13206730</p>	<p>The instruction list contains:</p> <ul style="list-style-type: none"> <li>• List of the instruction set of the CPUs and their execution times.</li> <li>• List of the executable blocks (OBs/SFCs/SFBs) and their execution times.</li> </ul>
<p><b>Getting Started</b></p> <ul style="list-style-type: none"> <li>• S7-300 Getting Started Collection                      Entry ID: 15390497</li> <li>• PROFINET Getting Started Collection                      Entry ID: 19290251</li> </ul>	<p>The collections use concrete examples to provide step-by-step instructions on how to commission a fully functional application.</p> <p><b>S7-300 Getting Started Collection:</b></p> <ul style="list-style-type: none"> <li>• CPU 31x: Start-up</li> <li>• CPU 31xC: Start-up</li> <li>• CPU 314C: Positioning with analog output</li> <li>• CPU 314C: Positioning with digital output</li> <li>• CPU 31xC: Counting</li> <li>• CPU 31xC: Point-to-point connection</li> <li>• CPU 31xC: Rules</li> </ul> <p><b>PROFINET Getting Started Collection:</b></p> <ul style="list-style-type: none"> <li>• CPU 315-2 PN/DP, CPU 317-2 PN/DP and CPU 319-3 PN/DP: Configuring the PROFINET interface</li> <li>• CPU 317-2 PN/DP: Configuring an ET 200S as PROFINET IO device</li> </ul>

## Further Information

You also require information from the following descriptions:

Name of the manual	Description
<b>STEP 7</b>	
System software for S7-300/400 system and standard functions Volume 1/2 Entry ID: 1214574	Overview of the OBs, SFCs, SFBs, IEC functions, diagnostics data, system status list (SSL) and events in the operating systems of the CPUs of the S7-300 and S7-400.  This manual is part of the STEP 7 reference information. You can also find the description in the online help for STEP 7.
Programming with STEP 7 Entry ID: 18652056	This manual provides a complete overview of programming with the STEP 7 Standard Package.  This manual is part of the STEP 7 Standard Package basic information. A description is also available in the online help for STEP 7.
<b>PROFINET</b>	
PROFINET System Description Entry ID: 19292127	<ul style="list-style-type: none"> <li>• Basic description of PROFINET:</li> <li>• Network components</li> <li>• Data exchange and communication</li> <li>• PROFINET IO</li> <li>• Component Based Automation</li> <li>• Application example of PROFINET IO and Component Based Automation</li> </ul>
From PROFIBUS DP to PROFINET IO Entry ID: 19289930	Guideline for the migration from PROFIBUS DP to PROFINET I/O.
SIMATIC NET: Twisted Pair and Fiber-Optic Networks Entry ID: 8763736	Description of Industrial Ethernet networks, network configuration, components, installation guidelines for networked automation systems in buildings, etc.
<b>Component Based Automation</b>	
Configure SIMATIC iMap plants Entry ID: 22762190	Description of the SIMATIC iMap configuration software
SIMATIC iMap STEP 7 AddOn, create PROFINET components Entry ID: 22762278	Descriptions and instructions for creating PROFINET components with STEP 7 and for using SIMATIC devices in Component Based Automation
Isochronous mode Entry ID: 15218045	Description of the system property "Isochronous mode"
SIMATIC communication Entry ID: 1254686	Basics, services, networks, communication functions, connecting PGs/OPs, engineering and configuring in STEP 7.

### Service & support on the Internet

Information on the following topics can be found on the Internet (<http://www.siemens.com/automation/service>):

- Contacts for SIMATIC (<http://www.siemens.com/automation/partner>)
- Contacts for SIMATIC NET (<http://www.siemens.com/simatic-net>)
- Training (<http://www.sitrain.com>)

## 1.2 Guide to the S7-300 documentation

### Overview

The following tables contain a guide through the S7-300 documentation.

#### Ambient influence on the automation system

Information about ...	is available in the manual ...	In Section ...
What provisions do I have to make for automation system installation space?	CPU 31xC and CPU 31x: Installation	Configuring – Component dimensions Mounting – Installing the mounting rail
How do environmental conditions influence the automation system?	CPU 31xC and CPU 31x: Installation	Appendix

#### Galvanic isolation

Information about ...	is available in the manual ...	In Section ...
Which modules can I use if electrical isolation is required between sensors/actuators?	CPU 31xC and CPU 31x: Installation Module data	Configuring – Electrical assembly, protective measures and grounding
Under what conditions do I have to isolate the modules electrically? How do I wire that?	CPU 31xC and CPU 31x: Installation	Configuring – Electrical assembly, protective measures and grounding Wiring
Under which conditions do I have to isolate stations electrically? How do I wire that?	CPU 31xC and CPU 31x: Installation	Configuring – Configuring subnets

## Communication between sensors/actuators and the PLC

Information about ...	is available in the manual ...	In Section ...
Which module is suitable for my sensor/actuator?	<ul style="list-style-type: none"> <li>• CPU 31xC and CPU 31x: Technical Data</li> <li>• For your signal module</li> </ul>	Technical Data
How many sensors/actuators can I connect to the module?	<ul style="list-style-type: none"> <li>• CPU 31xC and CPU 31x: Technical Data</li> <li>• For your signal module</li> </ul>	Technical Data
How do I connect my sensors/actuators to the automation system, using the front connector?	CPU 31xC and CPU 31x: Installation	Wiring – Wiring the front connector
When do I need expansion modules (EM) and how do I connect them?	CPU 31xC and CPU 31x: Installation	Configuring – Distribution of modules to several racks
How do I mount modules on racks / mounting rails?	CPU 31xC and CPU 31x: Installation	Assembly – Installing modules on the mounting rail

## The use of local and distributed IOs

Information about ...	is available in the manual ...	In Section ...
Which range of modules do I want to use?	<ul style="list-style-type: none"> <li>• Module data (for centralized IOs and expansion devices)</li> <li>• of the respective peripheral (for distributed IOs / PROFIBUS DP)</li> </ul>	–

## Configuration consisting of the central controller and expansion units

Information about ...	is available in the manual ...	In Section ...
Which rack / mounting rail is most suitable for my application?	CPU 31xC and CPU 31x: Installation	Configuring
Which interface modules (IM) do I need to connect the expansion units to the central controller?	CPU 31xC and CPU 31x: Installation	Configuring – Distribution of modules to several racks
What is the right power supply (PS) for my application?	CPU 31xC and CPU 31x: Installation	Configuring

### CPU performance

Information about ...	is available in the manual ...	In Section ...
Which memory concept is best suited to my application?	CPU 31xC and CPU 31x: Technical Data	Memory concept
How do I insert and remove Micro Memory Cards?	CPU 31xC and CPU 31x: Installation	Commissioning – Commissioning modules – Removing / inserting a Micro Memory Card (MMC)
Which CPU meets my demands on performance?	S7-300 instruction list: CPU 31xC and CPU 31x	–
Length of the CPU response / execution times	CPU 31xC and CPU 31x: Technical Data	–
Which technological functions are implemented?	Technological functions	–
How can I use these technological functions?	Technological functions	–

### Communication

Information about ...	is available in the manual ...	In Section ...
Which principles do I have to take into account?	<ul style="list-style-type: none"> <li>• CPU 31xC and CPU 31x: Technical Data</li> <li>• Communication with SIMATIC</li> <li>• PROFINET System Description</li> </ul>	Communication
Options and resources of the CPU	CPU 31xC and CPU 31x: Technical Data	Technical Data
How to use communication processors (CPs) to optimize communication	CP Manual	–
Which type of communication network is best suited to my application?	CPU 31xC and CPU 31x: Installation	Configuring – Configuring subnets
How do I network the various components?	CPU 31xC and CPU 31x: Installation	Configuring – Configuring subnets
What to take into account when configuring PROFINET networks	SIMATIC NET, twisted-pair and fiber-optic networks (6GK1970-1BA10-0AA0)	Network configuration
	PROFINET System Description	Installation and commissioning

### Software

Information about ...	is available in the manual ...	In Section ...
Software requirements of my S7-300 system	CPU 31xC and CPU 31x: Technical Data	Technical Data

## Supplementary features

<b>Information about ...</b>	<b>is available in ...</b>
How can I implement operation and monitoring functions? (Human Machine Interface)	The relevant Manual: <ul style="list-style-type: none"><li>• For text-based displays</li><li>• For Operator Panels</li><li>• For WinCC</li></ul>
How to integrate process control modules	Respective PCS7 manual
What options are offered by redundant and fail-safe systems?	S7-400H – Fault-Tolerant Systems Failsafe systems
Information to be observed when migrating from PROFIBUS DP to PROFINET IO	From PROFIBUS DP to PROFINET IO





# Installation Order

We will start by showing you the sequence of steps you have to follow to install your system. Then we will go on to explain the basic rules that you should follow, and how you can modify an existing system.

## Installation procedure

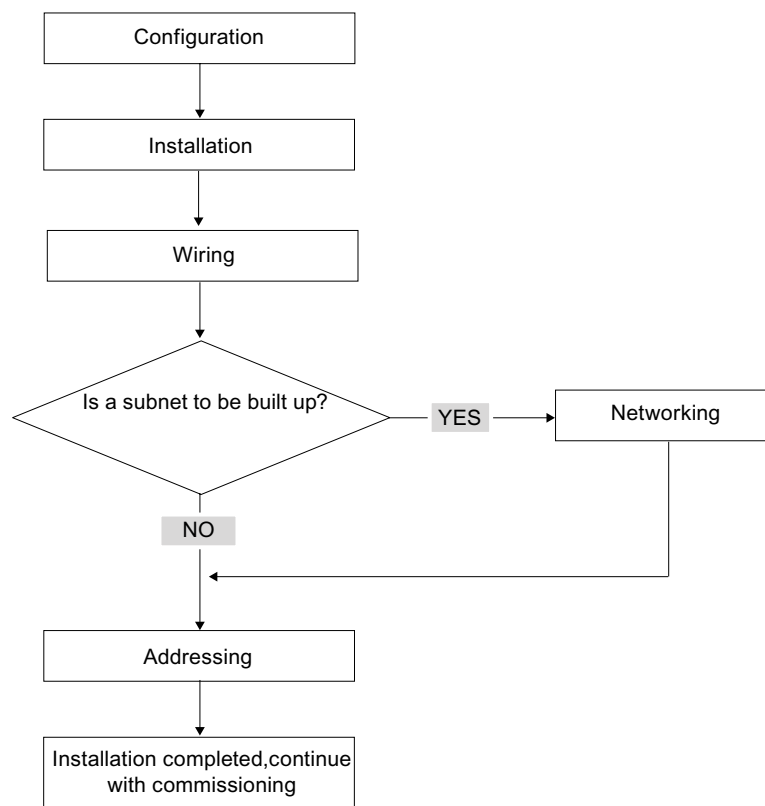

## Basic rules for trouble-free operation of the S7 system

In view of the many and versatile applications, we can only provide basic rules for the electrical and mechanical installation in this section.

You have to at least keep to these basic rules in order to obtain a fully functional SIMATIC-S7 system.

### **Modifying the existing S7 system structure**

To modify the configuration of an existing system, proceed as described earlier.

---

#### **Note**

When adding a new signal module, always refer to the relevant module information.

---

### **Reference**

Also refer to the description of the various modules in the manual: *SIMATIC S7-300 Automation Systems, Module Data Manual*.

## S7-300 components

### 3.1 Example of an S7-300 configuration

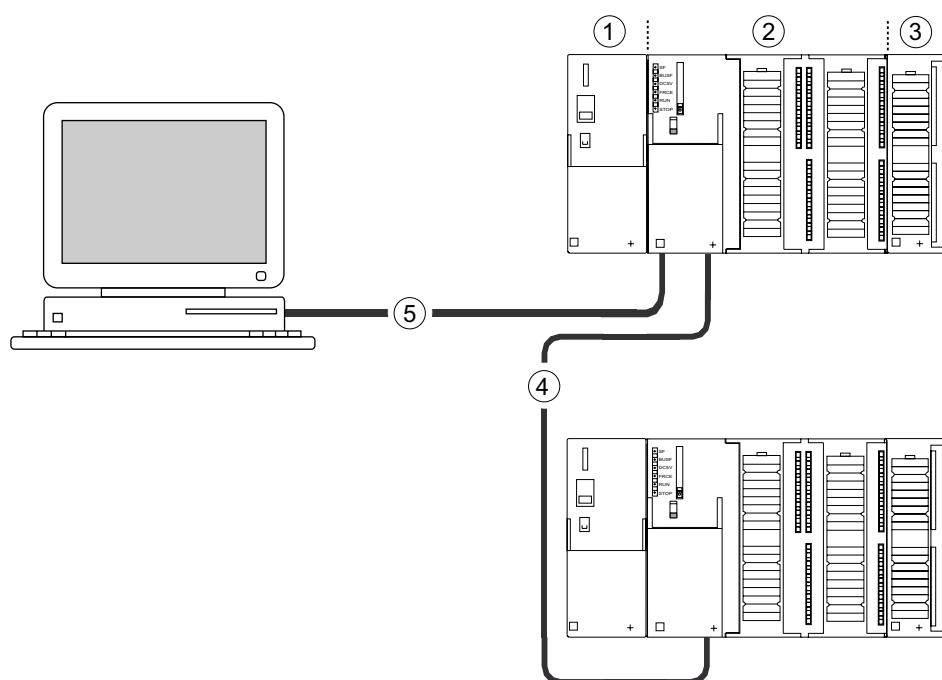

Number	Description
①	Power supply (PS) module
②	Central processing unit (CPU); the example in the diagram shows a CPU 31xC with integrated I/O.
③	Signal module (SM)
④	PROFIBUS bus cable
⑤	Cable for connecting a programming device (PG)

You use a programming device (PG) to program the S7300 PLC. Use the PG cable to interconnect the PG with the CPU.



To commission or program a CPU with PROFINET interface, you may also use an Ethernet cable to interconnect the PG with the PROFINET connector of the CPU.

Several S7-300 CPUs communicate with one another and with other SIMATIC S7 PLCs via the PROFIBUS cable. Several S7-300 are connected via the PROFIBUS bus cable.

### 3.2 Overview of the vital modules of an S7-300

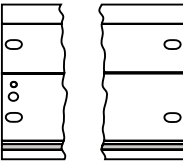
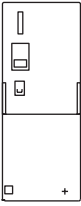
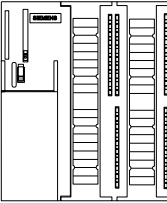
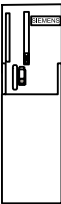

You can choose from a number of modules for installing and commissioning the S7-300. The most important modules and their functions are shown below.

Table 3- 1 S7-300 components:

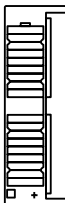
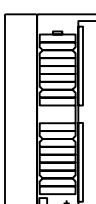
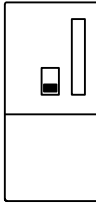
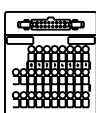
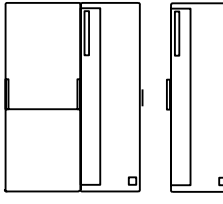
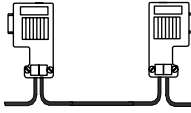
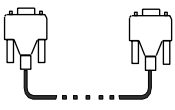
Component	Function	Illustration
Mounting rail Accessories: <ul style="list-style-type: none"> <li>• Shielding terminal</li> </ul>	S7-300 racks	
Power supply (PS) module	The PS converts the line voltage (120/230 VAC) into a 24 VDC operating voltage, and supplies the S7-300 and its 24 VDC load circuits.	
CPU Accessories: <ul style="list-style-type: none"> <li>• Front connectors (CPU 31xC only)</li> </ul>	The CPU executes the user program, supplies 5 V to the S7-300 backplane bus, and communicates with other nodes of an MPI network via the MPI interface.  Additional features of specific CPUs: <ul style="list-style-type: none"> <li>• DP master or DP slave on a PROFIBUS subnet</li> <li>• Technological functions</li> <li>• PtP communication</li> <li>• Ethernet communication via integrated PROFINET interface</li> </ul>	<div style="display: flex; flex-direction: column; align-items: center;"> <div style="display: flex; align-items: center; margin-bottom: 10px;">  <div style="margin-left: 10px;">A CPU 31xC, for example</div> </div> <div style="display: flex; align-items: center; margin-bottom: 10px;">  <div style="margin-left: 10px;">A CPU 312, 314, or 315-2 DP, for example</div> </div> <div style="display: flex; align-items: center;">  <div style="margin-left: 10px;">A CPU 317, for example</div> </div> </div>

Component	Function	Illustration
<p>Signal modules (SM)</p> <ul style="list-style-type: none"> <li>• Digital input modules</li> <li>• Digital output modules</li> <li>• Digital I/O modules,</li> <li>• Analog input modules</li> <li>• Analog output modules</li> <li>• Analog I/O modules</li> </ul> <p>Accessories:</p> <ul style="list-style-type: none"> <li>• Front connectors</li> </ul>	The SM matches different process signal levels to the S7-300.	
<p>Function modules (FM)</p> <p>Accessories:</p> <ul style="list-style-type: none"> <li>• Front connectors</li> </ul>	The FM performs time-critical and memory-intensive process signal processing tasks. Positioning or controlling, for example	
<p>Communication processor (CP)</p> <p>Accessories: Connecting cable</p>	The CP relieves the CPU of communication tasks. Example: CP 342-5 DP for connecting to PROFIBUS DP	
<p>SIMATIC TOP connect</p> <p>Accessories:</p> <ul style="list-style-type: none"> <li>• Front connector module with ribbon cable terminals</li> </ul>	Wiring of digital modules	
<p>Interface module (IM)</p> <p>Accessories:</p> <ul style="list-style-type: none"> <li>• Connecting cable</li> </ul>	The IM interconnects the various rows in an S7-300	
PROFIBUS cable with bus connector	Interconnect the nodes of an MPI or PROFIBUS subnet	
PG cable	Connects a PG/PC to a CPU	

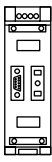
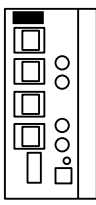
3.2 Overview of the vital modules of an S7-300

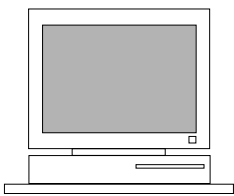
Component	Function	Illustration
RS 485 repeater RS 485 Diagnostic Repeater	The repeater is used to amplify the signals and to couple segments of an MPI or PROFIBUS subnet.	
Switch	A switch is used to interconnect the Ethernet nodes.	
Twisted-pair cables with RJ45 connectors.	Interconnects devices with Ethernet interface (a switch with a CPU 317-2 PN/DP, for example)	
Programming device (PG) or PC with the STEP 7 software package	You need a PG to configure, set parameters, program and test your S7-300	

# Configuring

## 4.1 Overview

There, you can find all the necessary information

- for the mechanical configuration of an S7-300,
- for the electrical configuration of an S7-300,
- that has to be observed in networking.

### Reference

For more detailed information, refer to

- the *Communication with SIMATIC* manual or
- the *SIMATIC NET Twisted-Pair and Fiber-Optic Networks Manual* (6GK1970-1BA10-0AA0)

## 4.2 Basic engineering principles

### Important information for engineering

#### WARNING

##### Open equipment

S7-300 modules are open equipment. That is, the S7-300 must be installed in a cubicle, cabinet or electrical control room which can only be accessed using a key or tool. Only trained or authorized personnel are allowed access to such cubicles, cabinets or electrical operating rooms.

#### CAUTION

Operation of an S7-300 in plants or systems is defined by special set of rules and regulations, based on the relevant field of application. Observe the safety and accident prevention regulations for specific applications, for example, the machine protection directives. This chapter and the appendix *General rules and regulations on S7-300 operation* provide an overview of the most important rules you need to observe when integrating an S7-300 into a plant or a system.





## 4.3 Component dimensions

### Length of the mounting rails

Table 4- 1 Mounting rails - Overview

Mounting rail length	Usable length for modules	Order No.
160 mm	120 mm	6ES7 390-1AB60-0AA0
482.6 mm	450 mm	6ES7 390-1AE80-0AA0
530 mm	480 mm	6ES7 390-1AF30-0AA0
830 mm	780 mm	6ES7 390-1AJ30-0AA0
2000 mm	cut to length as required	6ES7 390-1BC00-0AA0

In contrast to other rails, the 2 m mounting rail is not equipped with any fixing holes. These must be drilled, allowing optimal adaptation of the 2 m rail to your application.

### Installation Dimensions of the Modules

Table 4- 2 Module width

Module	Width
Power supply module PS 307, 2 A	50 mm
Power supply module PS 307, 5 A	80 mm
Power supply module PS 307, 10 A	200 mm
CPU	For information on assembly dimensions, refer to the Technical Data in <i>CPU 31xC and CPU 31x Manual, Technical Data</i> .
Analog I/O modules	40 mm
Digital I/O modules	40 mm
Simulator module SM 374	40 mm
Interface modules IM 360 and IM 365	40 mm
Interface module IM 361	80 mm

- Module height: 125 mm
- Module height with shielding contact element: 185 mm
- Maximum assembly depth: 130 mm
- Maximum assembly depth of a CPU with an inserted DP connector with angled cable feed: 140 mm
- Maximum assembly depth with open front panel (CPU): 180 mm

Dimensions of other modules such as CPs, FMs etc. are found in the relevant manuals.

### Shielding contact element

The direct contact between the shielding contact element and the mounting rail makes it easy for you to connect all shielded cables of your S7 modules to ground.

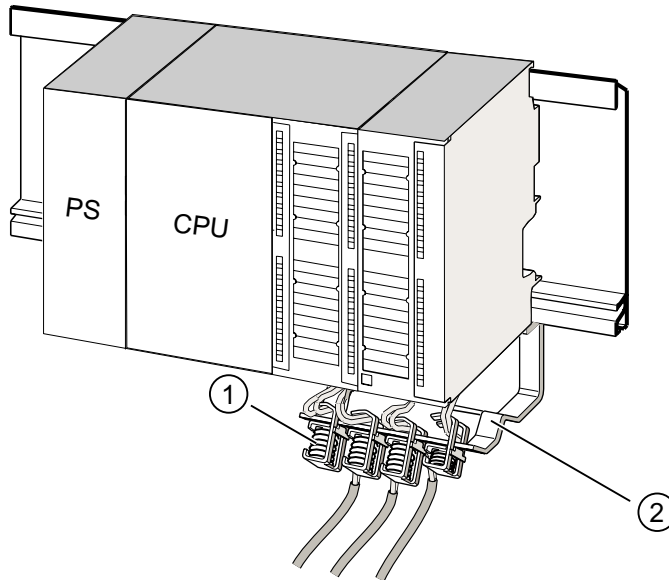

Number	Description
①	Shielding terminals
②	The bracket.

Mount the bracket (order number. 6ES7 390-5AA0-0AA0) to the rail using the two screw bolts. If you use a shielding contact element, the specified dimensions are measured from the base of the element.

- Width of the shielding contact element: 80 mm
- Mountable terminal elements per shield connecting element max. 4

Table 4-3 Shielding terminals - Overview

Cable with shielding diameter	Shielding terminal order no.
Cable with 2 mm to 6 mm shielding diameter	6ES7 390-5AB00-0AA0
Cable with 3 mm to 8 mm shielding diameter	6ES7 390-5BA00-0AA0
Cable with 4 mm to 13 mm shielding diameter	6ES7 390-5CA00-0AA0

## 4.4 Specified clearances

You must maintain the clearance shown in the figure in order to provide sufficient space for installing the modules, and to allow the dissipation of heat generated by the modules.

The S7-300 assembly on multiple racks shown in the figure below shows the clearance between racks and adjacent components, cable ducts, cabinet walls etc.

For example, when routing your module wiring through cable duct, the minimum clearance between the bottom of the shield connection element and the cable duct is 40 mm.

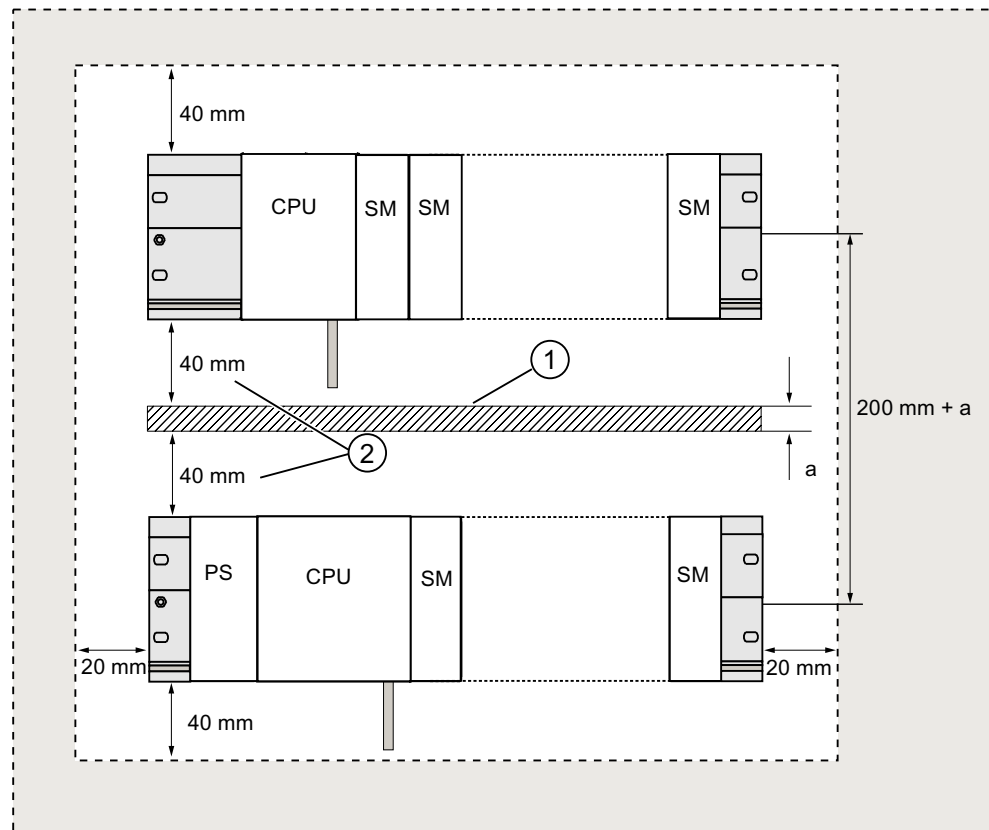

Number	Description
①	Wiring with cable duct
②	Minimum clearance between the cable duct and the bottom edge of the shielding contact element is 40 mm

## 4.5 Arrangement of modules on a single rack

### Reasons for using one or multiple racks

The number of racks you need will depend on your application.

Reasons for using a single rack:	Reasons for distributing modules between several racks
<ul style="list-style-type: none"><li>• Compact, space-saving use of all your modules</li><li>• Local use of all modules</li><li>• Fewer signals to be processed</li></ul>	<ul style="list-style-type: none"><li>• More signals to be processed</li><li>• Insufficient number of slots</li></ul>

---

#### Note

If you opt for the installation on a single rack, insert a dummy module to the right of the CPU (order no.: 6ES7 370-0AA01-0AA0). This gives you the option of adding a second rack for your application, simply by replacing the dummy module with an interface module, and without having to reinstall and rewire the first rack.

---

### Rules: Layout of modules on a single module rack

The following rules apply to module installations on a single rack:

- No more than eight modules (SM, FM, CP) may be installed to the right of the CPU.
- The accumulated power consumption of modules mounted on a rack may not exceed 1.2 A on the S7-300 backplane bus.

### Reference

Further information is available in the technical data, for example, in the SIMATIC S7-300 Automation Systems Manual, Module data, or in the *S7-300 Manual*, *CPU 31xC and CPU 31x, Technical Data*.

## Example

The figure below shows a layout with eight signal modules in an S7-300 assembly.

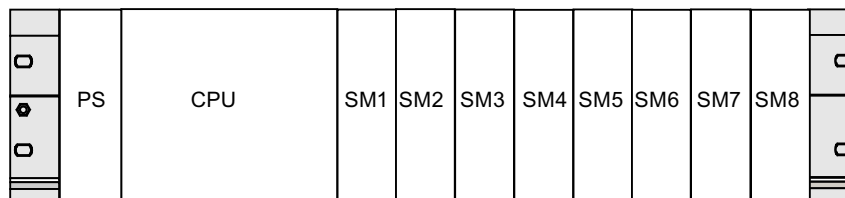

## 4.6 Distribution of modules to several racks

### Exceptions

With CPU 312 and CPU 312C, only a single-row configuration on a rack is possible.

### Using interface modules

If you are planning an assembly in multiple racks, then you will need interface modules (IM). An interface module routes the backplane bus of an S7-300 to the next rack.

The CPU is always located on rack 0.

Table 4-4 Interface modules - Overview

Properties	Two or more rows	Cost-effective 2-row configuration
Send IM in rack 0	IM 360 order no.: 6ES7 360-3AA01-0AA0	IM 365 order no.: 6ES7 365-0AB00-0AA0
Receiver IM in racks 1 to 3	IM 361 order no.: 6ES7 361-3CA01-0AA0	IM 365 (hard-wired to send IM 365)
Maximum number of expansion modules	3	1
Length of connecting cables	1 m (6ES7 368-3BB01-0AA0) 2.5 m (6ES7 368-3BC51-0AA0) 5 m (6ES7 368-3BF01-0AA0) 10 m (6ES7 368-3CB01-0AA0)	1 m (hard-wired)
Remarks	-	Rack 1 can only receive signal modules; the accumulated current load is limited to 1.2 A, whereby the maximum for rack 1 is 0.8 A  These restrictions do not apply to operation with interface modules IM 360/IM 361

### Rules: Distribution of modules to several racks

Please note the following points if you wish to arrange your modules on multiple racks:

- The IM always uses slot 3 (slot 1: power supply module; slot 2: CPU, slot 3: Interface module)
- It is always on the left before the first signal module.
- No more than 8 modules (SM, FM, CP) are permitted per rack.
- The number of modules (SM, FM, CP) is limited by the permitted current consumption on the S7-300 backplane bus. The accumulated power consumption may not exceed 1.2 A per row.

---

#### Note

For information on the current consumption of the modules, refer to the *SIMATIC Automation Systems S7-300, Module Specifications Manual*.

---

### Rules: Interference-proof interfacing

Special shielding and grounding measures are not required if you interconnect the CU and EM using suitable interface modules (Send IM and Receive IM).

However, you must ensure

- a low impedance interconnection of all racks,
- that the racks of a grounded assembly are grounded in a star pattern,
- that the contact springs on the racks are clean and not bent, thus ensuring that interference currents are properly discharged to ground.

**Example: Full assembly using four racks**

The figure shows the arrangement of modules in an S7-300 assembly on 4 racks.



- | Number | Description  |
|--------|--|
| ①      | Rack 0 (central unit)  |
| ②      | Rack 1 (expansion module)  |
| ③      | Rack 2 (expansion module)  |
| ④      | Rack 3 (expansion module)  |
| ⑤      | The connecting cable 368   |
| ⑥      | Restriction for CPU 31xC. When this CPU is used, do not insert SM 8 into Rack 4. |

## 4.7 Selection and installation of cabinets

### Reasons for installing an S7-300 in a cabinet

Your S7-300 should be installed in a cabinet,

- if you plan a larger system,
- if you are using your S7-300 systems in an environment subject to interference or contamination, and
- to meet UL/CSA requirements for cabinet installation.

### Selecting and dimensioning cabinets

Take the following criteria into account:

- ambient conditions at the cabinet's place of installation
- the specified mounting clearance for racks (mounting rails)
- accumulated power loss of all components in the cabinet.

The ambient conditions (temperature, humidity, dust, chemical influence, explosion hazard) at the cabinet's place of installation determine the degree of protection (IP xx) required for the cabinet.

### Reference for degrees of protection

For further information on the degrees of protection, refer to IEC 529 and DIN 40050.

### The power dissipation capability of cabinets

The power dissipation capability of a cabinet depends on its type, ambient temperature and on the internal arrangement of devices.

### Reference for power loss

For detailed information on dissipatable power loss, refer to the Siemens catalogs. You can find these at: <https://mall.automation.siemens.com/de/guest/guiRegionSelector.asp>



### Specification of cabinet dimensions

Note the following specifications when you determine the dimensions of a cabinet for your S7-300 installation:

- Space required for racks (mounting rails)
- Minimum clearance between the racks and cabinet walls
- Minimum clearance between the racks
- Space required for cable ducts or fan assemblies
- Position of the stays

 <b>WARNING</b>
--

Modules may get damaged if exposed to excess ambient temperatures.
--

### Reference for ambient temperatures

For information on permitted ambient temperatures, refer to the *S7-300 Automation System, Module Data* Manual.

**Overview of typical cabinet types**

The table below gives you an overview of commonly used cabinet types. It shows you the applied principle of heat dissipation, the calculated maximum power loss and the degree of protection.

Table 4- 5 Cabinet types

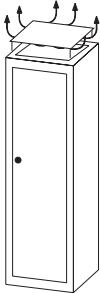
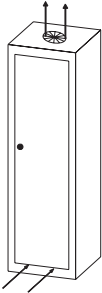
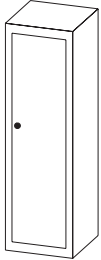
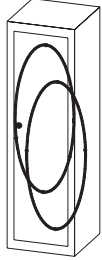
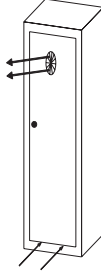
Open cabinets		Closed cabinets		
Through-ventilation by natural convection	Increased through-ventilation	Natural convection	Forced convection with rack fan, improvement of natural convection	Forced convection with heat exchanger, internal and external auxiliary ventilation
				
Mainly inherent heat dissipation, with a small portion across the cabinet wall.	Higher heat dissipation with increased air movement.	Heat dissipation only across the cabinet wall; only low power losses permitted. In most cases, the heat accumulates at the top of the cabinet interior.	Heat dissipation only across the cabinet wall. Forced convection of the interior air improves heat dissipation and prevents heat accumulation.	Heat dissipation by heat exchange between heated internal air and cool external air. The increased surface of the pleated profile of the heat exchanger wall and forced convection of internal and external air provide good heat dissipation.
Degree of protection IP 20	Degree of protection IP 20	Degree of protection IP 54	Degree of protection IP 54	Degree of protection IP 54
Typical power dissipation under following marginal conditions: <ul style="list-style-type: none"> <li>• Cabinet size: 600 mm x 600 mm x 2,200 mm</li> <li>• Difference between the outer and inner temperature of the cabinet is 20 °C (for other temperature differences refer to the temperature charts of the cabinet manufacturer)</li> </ul>				
up to 700 W	up to 2,700 W (with fine filter up to 1,400 W)	up to 260 W	up to 360 W	up to 1,700 W

## 4.8 Example: Selecting a cabinet

### Introduction

The sample below clearly shows the maximum permitted ambient temperature at a specific power loss for different cabinet designs.

### Installation

The following device configuration should be installed in a cabinet:

- Central unit, 150 W
- Expansion modules, each with 150 W
- Load power supply under full load, 200 W

This results in an accumulated power loss of 650 W.

### Power loss dissipated

The diagram in the figure below shows guide values for the permitted ambient temperature of a cabinet with the dimensions 600 mm x 600 mm x 2,000 mm, based on the accumulated power loss. These values only apply if you maintain the specified assembly and clearance dimensions for racks (rails).

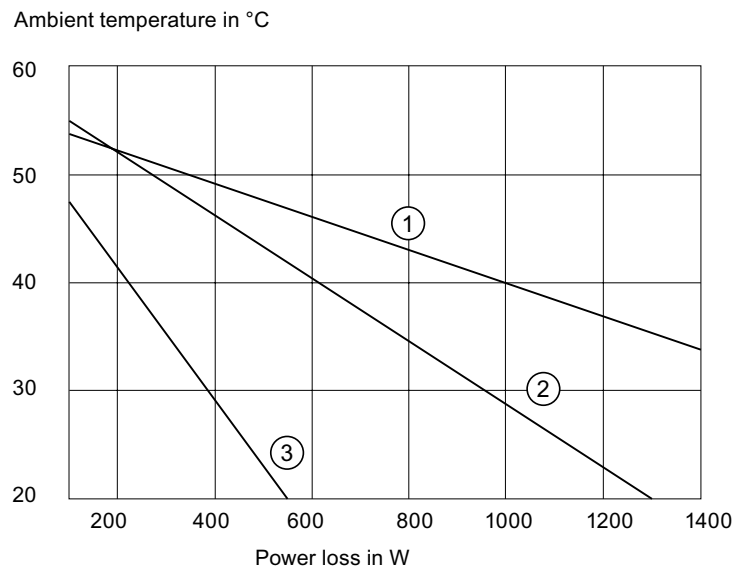

Number	Description
①	Closed cabinet with heat exchanger (heat exchanger size 11/6 (920 mm x 460 mm x 111 mm))
②	Cabinet with through-ventilation by natural convection
③	Closed cabinet with natural convection and forced convection by equipment fans

## Result

The figure below shows the resultant ambient temperatures, based on an accumulated power loss of 650 W:

Table 4- 6 Cabinet selection

Cabinet design	Maximum permitted ambient temperature
Closed with natural convection and forced convection (trend 3)	Operation not possible
Open with through-ventilation (trend 2)	approx. 38 °C
Closed with heat exchanger (trend 1)	approx. 45 °C

Cabinet types suitable for horizontal installation of the S7-300:

- open, with closed ventilation
- closed, with heat exchanger

## 4.9 Electrical assembly, protective measures and grounding

### 4.9.1 Grounding concept and overall structure

This section contains information about the overall configuration of an S7-300 connected to a grounded TN-S network:

- Circuit-breaking devices, short-circuit and overload protection to VDE 0100 and VDE 0113
- Load power supplies and load circuits
- Grounding concept

---

#### Note

An S7-300 can be used in many different ways, so we can only describe the basic rules for the electrical installation in this document. Those basic rules are a must in order to achieve a fully functional S7-300 system.

---

#### Definition: Grounded mains

In a grounded mains network, the neutral conductor is always bonded to ground. A short-circuit to ground of a live conductor, or of a grounded part of the system, trips the protective devices.

## Specified components and protective measures

A number of components and protective measures are prescribed for plant installations. The type of components and the degree of compulsion pertaining to the protective measures will depend on the VDE specification applicable to your particular plant.

The table below shows components and protective measures.

Table 4- 7 VDE specifications for the installation of a PLC system

Compare ...	1)	VDE 0100	VDE 0113
Disconnect devices for control systems, signal generators and final control elements	(1)	...Part 460: Master switch	... Part 1: Load disconnect switch
Short-circuit / overload protection: In groups for signal generators and final control elements	(2)	...Part 725: Single-pole fusing of circuits	... Part 1: <ul style="list-style-type: none"> <li>• With grounded secondary power circuit: single-pole fusing</li> <li>• Otherwise: fusing of all poles</li> </ul>
Load power supply for AC load circuits with more than five electromagnetic devices	(3)	Galvanic isolation by transformer recommended	Electrical isolation by transformer mandatory

1) This column refers to the indexes of the figure in the chapter "Overview: Grounding".

## Reference

For further information on protective measures, refer to the Appendix.

## See also

Overview display: Earthing (Page 45)

## 4.9.2 Installing an S7-300 with grounded reference potential

### Introduction

When the S7-300 is configured with a grounded reference potential, any interference currents are discharged to the grounding conductor / ground. A grounding slide contact is used for this except with CPU 31xC.

#### Note

Your CPU is supplied with grounded reference potential. Therefore, if you wish to install an S7-300 with grounded reference potential, you do not need to modify your CPU!

### Grounded reference potential of the CPU 31x

The figure shows an S7-300 configuration with grounded reference potential (factory state.)

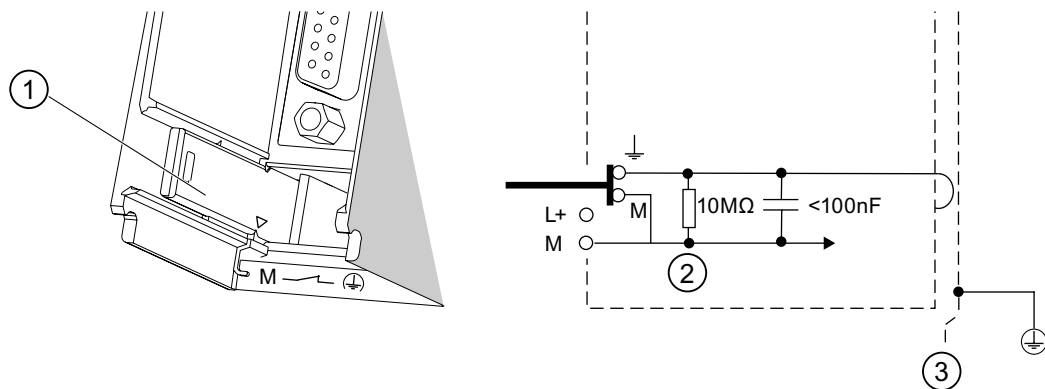

Number	Description
①	Grounding slide contact in grounded state
②	Ground of the internal CPU circuitry
③	The mounting rail

#### Note

Do not pull out the grounding slide contact when you install an S7-300 with grounded reference potential.

### 4.9.3 Installing an S7-300 with ungrounded reference potential (not CPU 31xC)

#### Introduction

When the S7-300 is configured with an ungrounded reference potential, interference currents are discharged to the ground conductor / to ground via an RC combination integrated in the CPU.

#### Note

An S7-300 with a CPU 31xC cannot be configured ungrounded.

#### Application

In large systems, the S7-300 may require a configuration with grounded reference potential due to ground-fault monitoring. This is the case, for example, in chemical industry and power stations.

#### Ungrounded reference potential of the CPU 31x

The figure shows an S7-300 configuration with floating potential

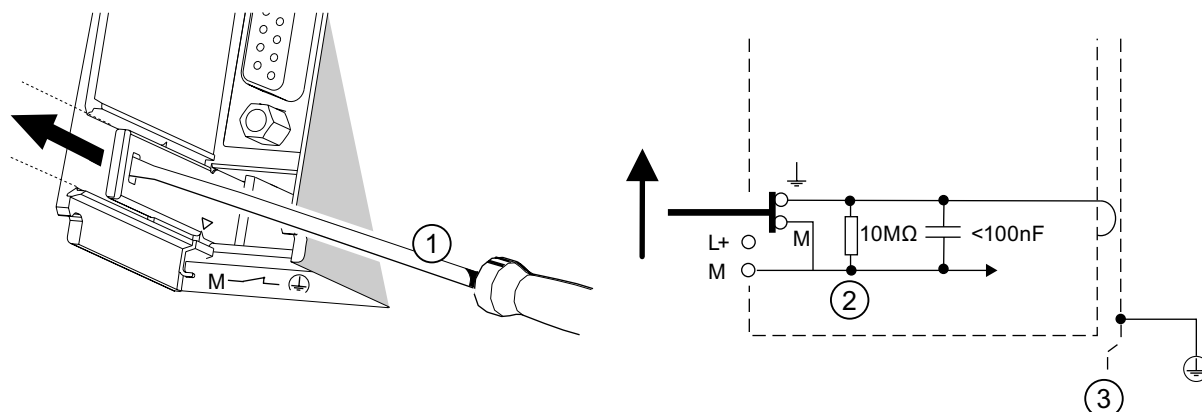

Number	Description
①	How to implement an ungrounded reference potential in your CPU: Use a screwdriver with 3.5 mm blade width to push the grounding slide contact forwards in the direction of the arrow until it snaps into place.
②	Ground of the internal CPU circuitry
③	The mounting rail.

#### Note

You should set up the ungrounded reference potential before you mount the device on the rail. If you have already installed and wired up the CPU, you may have to disconnect the MPI interface before you pull out the grounding slide contact.

## 4.9.4 Isolated or common potential modules?

### Isolated modules

Isolated modules are installed with galvanic isolation between the reference potentials of the control circuit ( $M_{\text{internal}}$ ) and load circuit ( $M_{\text{external}}$ .)

### Field of application

Use isolated modules for:

- All AC load circuits
- DC load circuits with separate reference potential

Examples:

- DC load circuits containing sensors which are connected to different reference potentials (for example, if grounded sensors are located at a considerable distance from the control system and equipotential bonding is not possible)
- DC load circuits with grounded positive pole (L+) (battery circuits.)

### Isolated modules and grounding concept

You can always use isolated modules, irrespective of the grounding state of the control system's reference potential.



### Example: Assembly with CPU 31xC and isolated modules

The figure below shows an example of such a configuration: A CPU 31xC with isolated modules. The CPU 31xC (1) is automatically grounded.

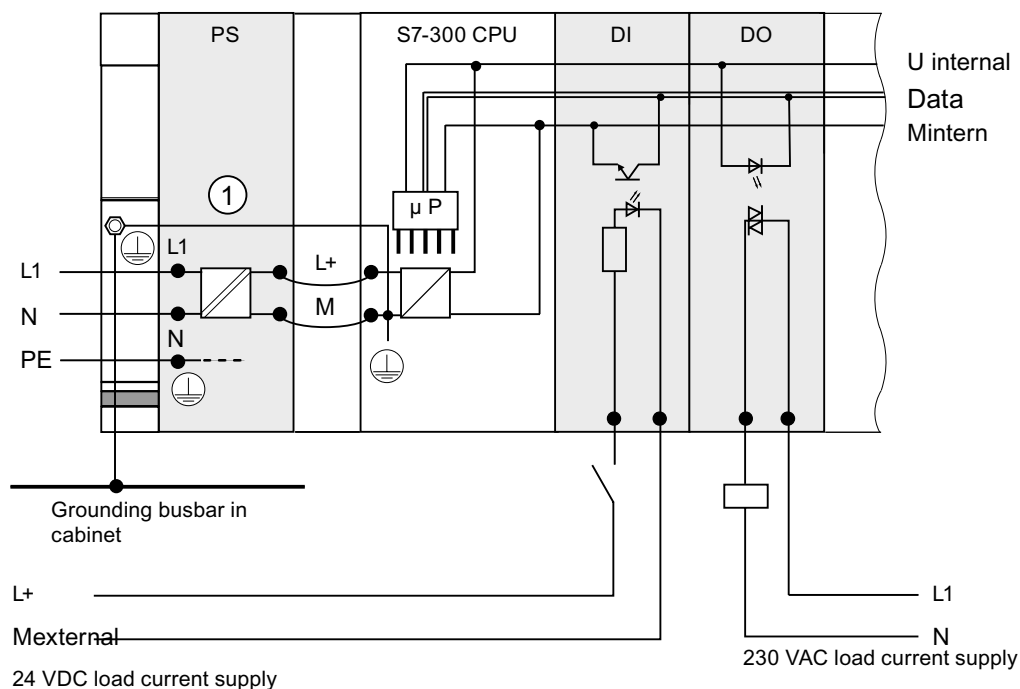

### Common potential modules

In a configuration containing modules with common potential, the reference potentials of the control circuit ( $M_{\text{internal}}$ ) and analog circuit ( $M_{\text{analog}}$ ) are not galvanically isolated.

**Example: Installing an S7-300 with common potential modules**

When using an SM 334 AI 4/AO 2 analog I/O module, connect one of the grounding terminals  $M_{analog}$  to the CPU's chassis ground.

The figure below shows an example of such a configuration: An S7-300 with common potential modules

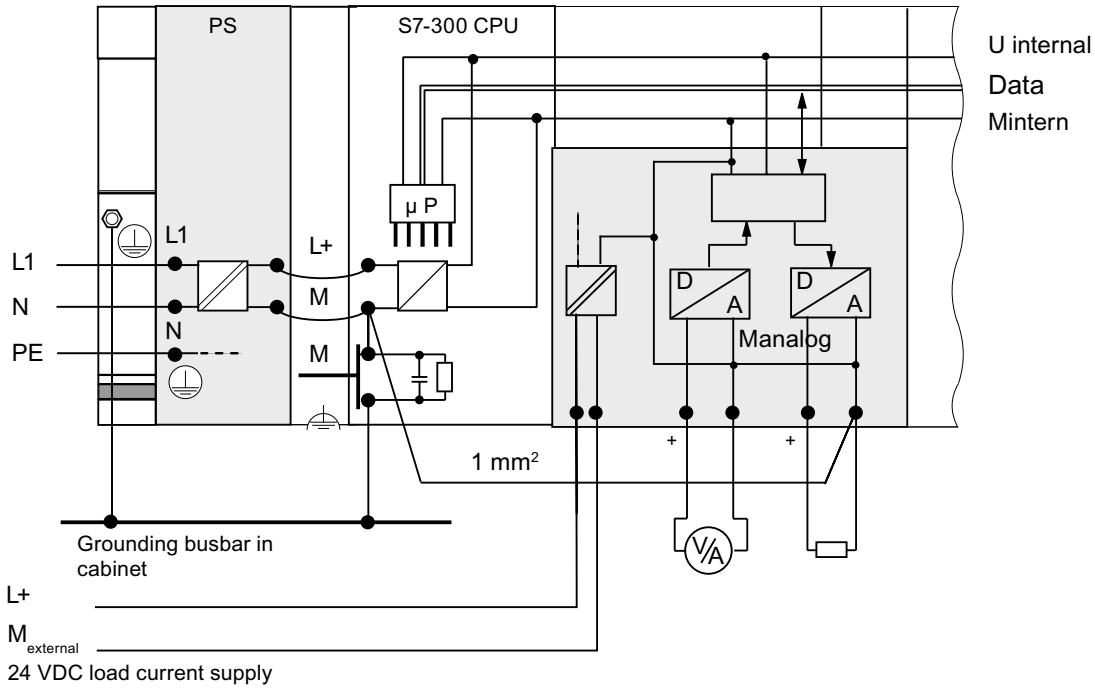

## 4.9.5 Grounding measures

### Bonding to ground

Low-impedance connections to ground reduce the risk of electric shock as a result of a short-circuit or system fault. Low-impedance connections (large surface, large-surface contact) reduce the effects of interference on the system or the emission of interference signals. An effective shielding of cables and devices is also a significant contribution.

 <b>WARNING</b>
All protection class 1 devices, and all larger metal parts, must be bonded to protective ground. That is the only way to safely protect operators from electrical shock. This also discharges any interference transmitted from external power supply cables, signal cables or cables to the I/O devices.

### Measures for protective grounding

The table below shows an overview of the most important measures for protective grounding.

Table 4- 8 Measures for protective grounding

Device	Measures
Cabinet / mounting frame	Connection to central ground (equipotential busbar, for example) using cables with protective conductor quality
Rack / mounting rail	Connection to central ground, using cables with a minimum cross-section of 10 mm <sup>2</sup> , if the rails are not installed in the cabinet and not interconnected with larger metallic parts.
Module	None
I/O Device	Grounding via grounding-type plug
Sensors and final control elements	Grounding in accordance with regulations applying to the system

### Rule: Connect the cable shielding to ground

You should always connect both ends of the cable shielding to ground / system ground. This is the only way to achieve an effective interference suppression in the higher frequency range.

Attenuation is restricted to the lower frequency range if you connect only one end of the shielding (that is, at the start or end of the cable) to ground. One-sided shielding connections could be more favorable in situations

- not allowing the installation of an equipotential bonding conductor,
- where analog signals (some mA or A) are transferred,
- or if foil shielding is used (static shielding).

**Note**

Potential differences between two grounding points might cause an equipotential current flow across shielding connected at both ends. In this case, you should install an additional equipotential bonding conductor.

 <b>CAUTION</b>
Always avoid the flow of operating current to ground.

**Rule: Load circuit grounding**

You should always ground the load circuits. This common reference potential (ground) ensures proper functioning.

**Note**

(not valid for CPU 31xC):

If you want to locate a fault to ground, provide your load power supply (terminal L or M) or the isolating transformer with a removable connection to the protective conductor (see *Overview: Grounding* section 4).

**Connecting the load voltage reference potential**

A complex system containing many output modules requires an additional load voltage for switching the final control elements.

The table below shows how to connect the load voltage reference potential  $M_{\text{external}}$  for the various configurations.

Table 4- 9 Connecting the load voltage reference potential

Installation	common potential modules	isolated modules	Note
grounded	Connect $M_{\text{external}}$ with M on the CPU	Connect or do not connect $M_{\text{external}}$ to the grounding busbar	-
ungrounded	Connect $M_{\text{external}}$ with M on the CPU	Connect or do not connect $M_{\text{external}}$ to the grounding busbar	Ungrounded installation with CPU 31xC is not possible

### 4.9.6 Overview display: Earthing

#### CPU 31xC

The figure below shows you the complete assembly of an S7-300 with CPU 31xC with a power supply from TN-S mains. Apart from powering the CPU, the PS 307 also supplies the load current for the 24 VDC modules. Remark: The layout of the power connections does not correspond with their physical arrangement; it was merely selected to give you a clear overview.

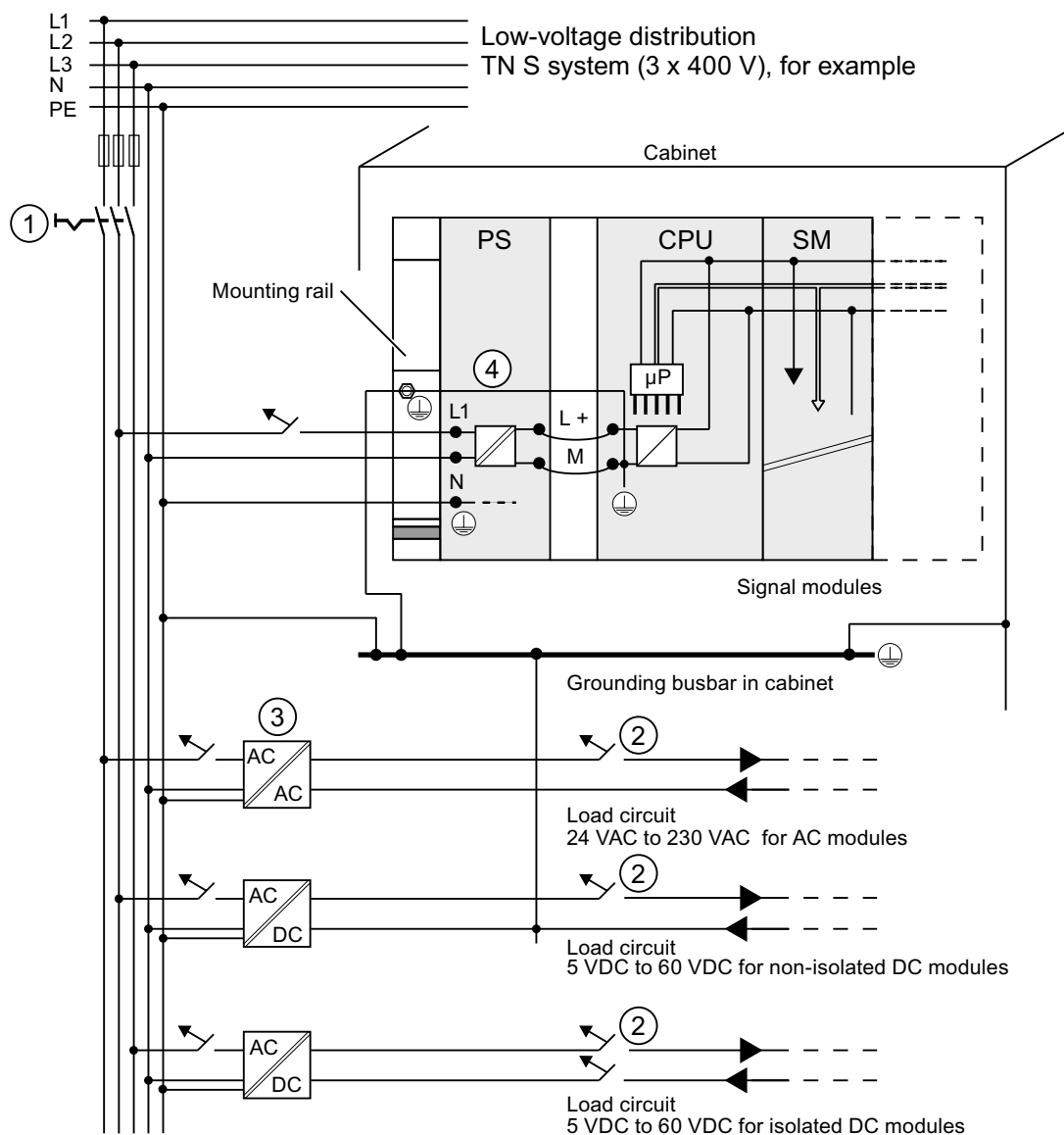

- | Number | Description  |
|--------|--|
| ①      | The main switch  |
| ②      | The short-circuit / overload protection                |
| ③      | The load current supply (galvanic isolation)           |
| ④      | This connection is made automatically for the CPU 31xC |

Figure 4-1 Connecting the load voltage reference potential

All CPUs except CPU 31xC

The figure below shows you the complete assembly of an S7-300 with TN-S mains supply (does not apply to CPU 31xC). Apart from powering the CPU, the PS 307 also supplies the load current for the 24 VDC modules.

Remark: The layout of the power connections does not correspond with their physical arrangement; it was merely selected to give you a clear overview.

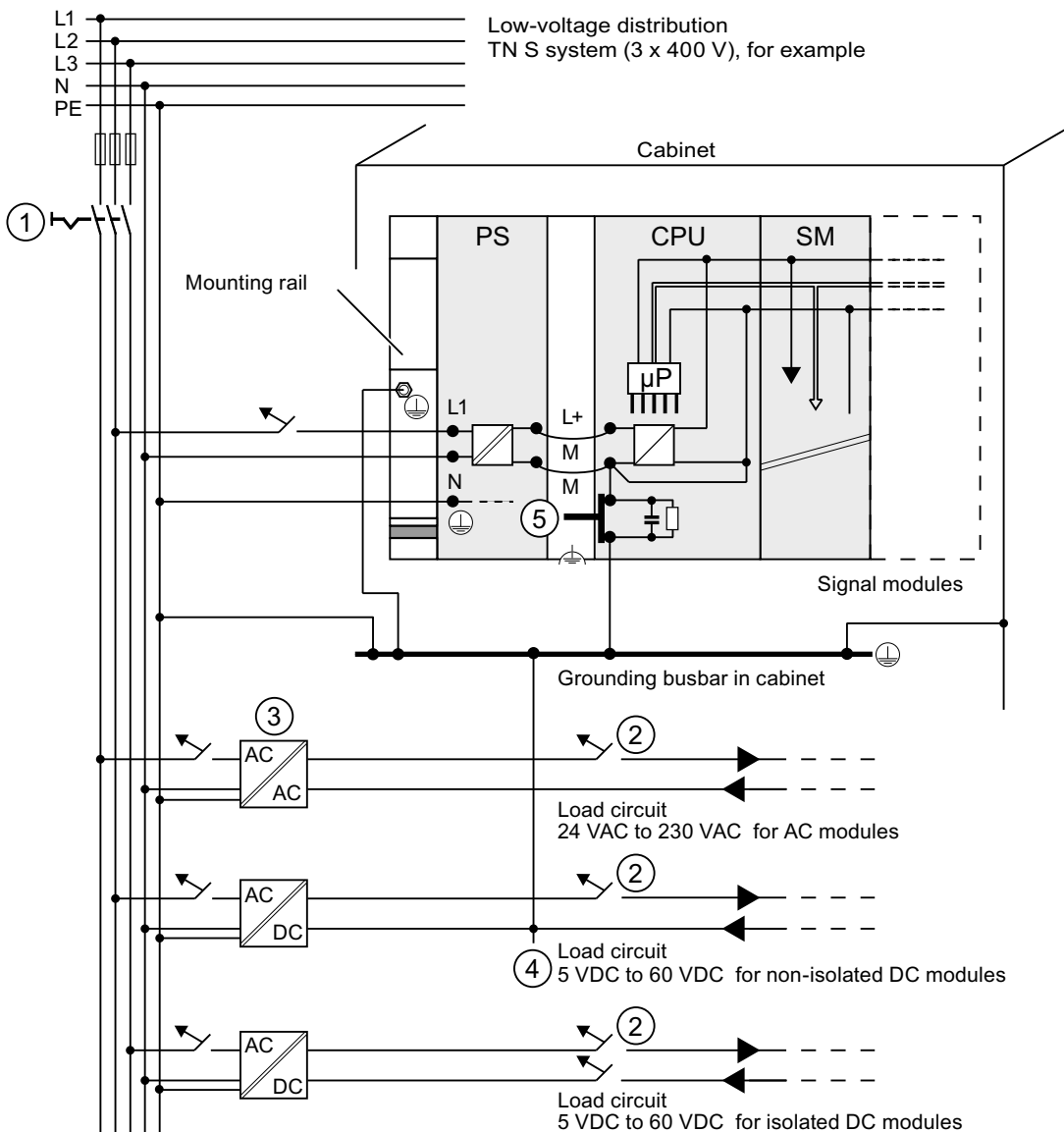

Number	Description
①	The main switch
②	The short-circuit / overload protection
③	The load current supply (galvanic isolation)
④	The removable connection to the grounding conductor, for ground fault localization
⑤	The grounding slide contact of the CPU (not CPU 31xC)

Figure 4-2 Connecting the load voltage reference potential

## 4.10 Selection of the load power supply

### Task of the load power supply

The load power supply feeds the input and output circuits (load circuits), and the sensors and actuators.

### Features of load power supply units

You will have to adapt the load power supply unit to your specific application. The table below shows a comparison of the various load power supply units and their features to help you make your choice:

Table 4- 10 Features of load power supply units

Necessary for ...	Feature of the load power supply	Remarks
Modules requiring voltage supplies $\leq 60$ VDC or $\leq 25$ VAC. 24 VDC load circuits	Safety isolation	This is a common feature of the Siemens power supply series PS 307 and SITOP power series 6EP1.
24 VDC load circuits 48 VDC load circuits 60 VDC load circuits	Output voltage tolerances: 20.4 V to 28.8 V 40.8 V to 57.6 V 51 V to 72 V	-

### Load power supply requirements

Only an extra-low voltage of  $\leq 60$  VDC which is safely isolated from mains may be used as load voltage. Safe isolation from mains can be achieved, for example, in accordance with VDE 0100 Part 410 / HD 384-4-41 / IEC 364-4-41 (as functional extra-low voltage with safe isolation) or VDE 0805 / EN 60950 / IEC 950 (as safety extra-low voltage SELV) or VDE 0106 Part 101.

### Load current determination

The required load current is determined by the accumulated load current of all sensors and actuators connected to the outputs.

A short-circuit induces a surge current at the DC outputs which is 2 to 3 times higher than the rated output current, until the clocked electronic short-circuit protection comes into effect. Make allowances for this increased short-circuit current when selecting your load power supply unit. Uncontrolled load power supplies usually provide this excess current. With controlled load power supplies, and particularly for low output power up to 20 A, always ensure that the supply can handle this excess current.

**Example: S7-300 with load power supply from PS 307**

The figure below shows the overall S7-300 configuration (load power supply unit and grounding concept), with TN-S mains supply. The PS 307 supplies the CPU and the load current circuit of the 24 VDC modules.

**Note**

The layout of the power connections does not correspond with their physical arrangement; it was merely selected to give you a clear overview.

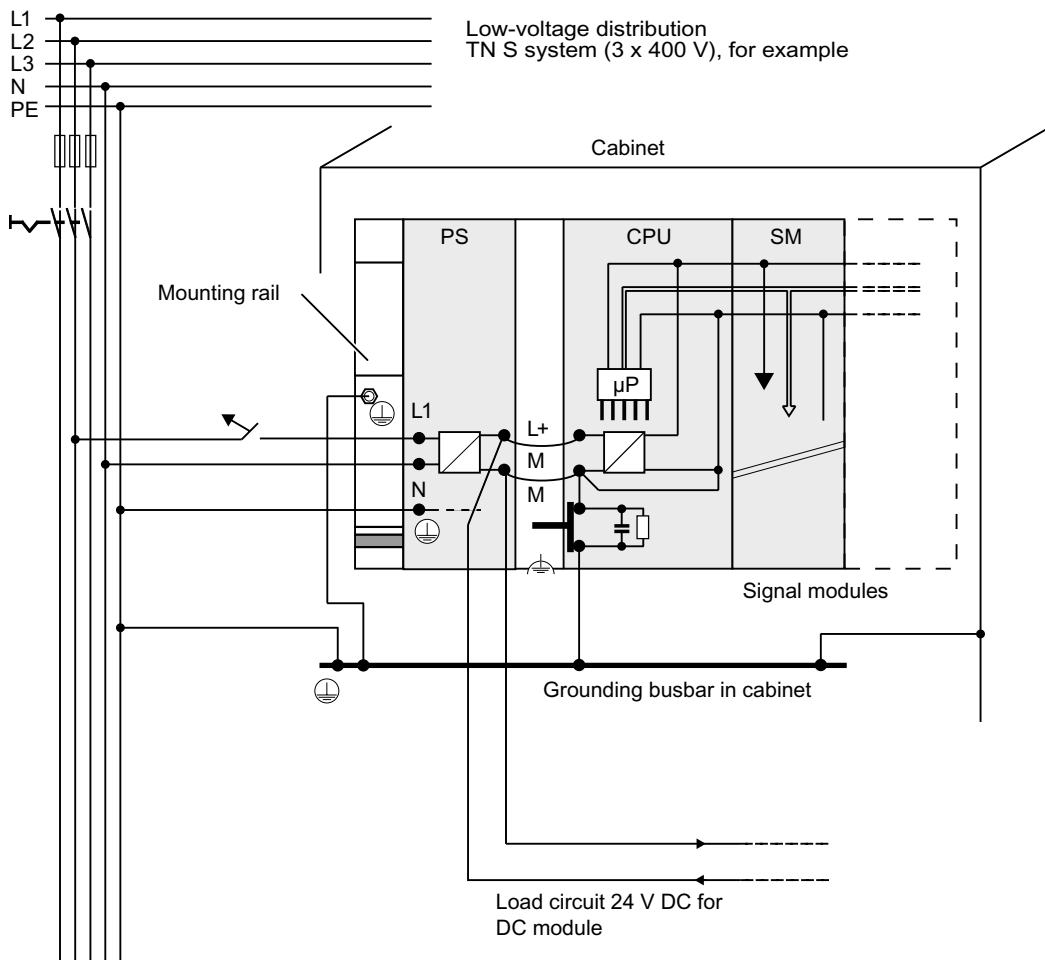

Example: S7-300 with load power supply from PS 307



## 4.11 Planning subnets

### 4.11.1 Overview

#### Subnets

Subnets available in SIMATIC for the various automation levels (process, cell, field and actuator/sensor level ):

- Multi-Point Interface (MPI)
- PROFIBUS
- PROFINET (Industrial Ethernet)
- Point-to-point communication (PtP)
- Actuator/Sensor Interface (ASI)

#### Multi-Point Interface (MPI)

Availability: For all CPUs described in this document.

MPI is a small area subnet containing a small number of nodes at the field/cell level. It is a multipoint-capable interface in SIMATIC S7/M7 and C7, designed as PG interface, for networking a small number of CPUs, or for low volume data exchange with PGs.

MPI always retains the last configuration of the transmission rate, node number and highest MPI address, even after CPU memory reset, power failure or deletion of the CPU parameter configuration.

It is advisable to use the PROFIBUS DP network components for your MPI network configuration. The same configuration rules apply. Exception: OWG modules are not allowed in the MPI network.

#### PROFIBUS

Availability: CPUs with the "DP" name suffix are equipped with a PROFIBUS interface (CPU 315-2 DP, for example).

PROFIBUS represents the network at the cell and field level in the SIMATIC open, multivendor communication system.

PROFIBUS is available in two versions:

1. PROFIBUS DP field bus for high-speed cyclic data exchange, and PROFIBUS-PA for intrinsically safe applications (requires DP/PA coupler).
2. The cell level as PROFIBUS (FDL or PROFIBUS FMS) for high-speed data exchange with communication partners at the same authorization level (can only be implemented via CP).

## PROFINET (Industrial Ethernet)

Availability: CPUs with the "PN" name suffix are equipped with a PROFINET interface (CPU 317-2 PN/DP or CPU 319-3 PN/DP for example). A PROFINET interface, or communication processors, can be used to implement Industrial Ethernet in an S7-300 CPU system.

Industrial Ethernet, in an open multivendor communication system, represents the SIMATIC network at the process and cell level. PROFINET CPUs, however, also support real-time communication at the field level. This structure also supports S7 communication. Industrial Ethernet is suitable for high-speed and high-volume data exchange, and for remote network operations via gateway.

PROFINET is available in two versions:

- PROFINET IO and
- PROFINET CBA.

**PROFINET IO** is a communication concept for the implementation of modular, distributed applications. PROFINET IO allows you to create automation solutions you are familiar with from PROFIBUS.

**PROFINET CBA** (Component based Automation) is an automation concept for the implementation of applications with distributed intelligence. PROFINET CBA lets you create distributed automation solutions, based on default components and partial solutions. This concept satisfies demands for a higher degree of modularity in the field of mechanical and systems engineering by extensive distribution of intelligent processes.

Component-Based Automation allows you to use complete technological modules as standardized components in complex systems.

## Point-to-point communication (PtP)

Availability: CPUs with "PtP" name suffix are equipped with a second interface, namely the PtP interface (CPU 314C-2 PtP, for example)

PtP does not represent a subnet in the common sense, because it is used to interconnect only two stations.

If a PtP interface is not available, you require PtP Communication Processors (CP).

## Actuator/Sensor Interface (ASI)

Implementation by means of communication processors (CP).

The ASI, or actuator/sensor interface, represents a subnet system on the lowest process level for automation systems. It is designed especially for networking digital sensors and actuators. The maximum data volume is 4 bits per slave station.

S7-300 CPUs require communication processor for the ASI connection.

## Reference

For further information on communication, refer to the *Communication with SIMATIC* manual.

## 4.11.2 Configuring MPI and PROFIBUS subnets

### 4.11.2.1 Overview

The next section contains all the information you require to configure MPI, PtP and PROFIBUS subnets:

#### Contents

- MPI, PtP and PROFIBUS subnets
- Multi-Point Interface
- PROFIBUS DP
- MPI and PROFIBUS network components
- Example of networks - MPI

### 4.11.2.2 Basic principles of MPI and PROFIBUS subnets

#### Convention: device = node

All devices you interconnect on the MPI or PROFIBUS network are referred to as nodes.

#### Segment

A segment is a bus line between two terminating resistors. A segment may contain up to 32 nodes. It is also limited with respect to the permitted line length, which is determined by the transmission rate.

#### Baud rate

Maximum transmission rates:

- MPI:
  - CPU 315-2 PN/DP, CPU 317 and CPU 319-3 DP/DP 12 Mbps
  - All other CPUs: 187.5 kbps
- PROFIBUS DP: 12 Mbps

**Number of nodes**

Maximum number of nodes per subnet:

Table 4- 11 Subnet nodes

Parameters	MPI	PROFIBUS DP
Number	127	126 <sup>1)</sup>
Addresses	0 to 126	0 to 125
Remark	Default: 32 addresses Reserved addresses: <ul style="list-style-type: none"> <li>• Address 0 for PG</li> <li>• Address 1 for OP</li> </ul>	of those: <ul style="list-style-type: none"> <li>• 1 master (reserved)</li> <li>• 1 PG connection (address 0 reserved)</li> <li>• 124 slaves or other masters</li> </ul>

<sup>1</sup> Note the CPU-specific maximum specifications in the relevant CPU manual.

**MPI/PROFIBUS DP addresses**

You need to assign an address to all nodes in order to enable intercommunication:

- On the MPI network: an "MPI address"
- On the PROFIBUS DP network: "a PROFIBUS DP address"

You can use the PG to set the MPI/PROFIBUS addresses for each one of the nodes (some of the PROFIBUS DP slaves are equipped with a selector switch for this purpose).

**Default MPI/PROFIBUS DP addresses**

The table below shows you the default setting of the MPI/PROFIBUS DP addresses, and the factory setting of the highest MPI/PROFIBUS DP addresses for the nodes.

Table 4- 12 MPI/PROFIBUS DP addresses

Node (device)	Default MPI/PROFIBUS DP address	Default highest MPI address	Default highest PROFIBUS DP address
PG	0	32	126
OP	1	32	126
CPU	2	32	126

**Rules: Assignment of MPI/PROFIBUS DP addresses**

Note the following rules before assigning MPI/PROFIBUS addresses:

- All MPI/PROFIBUS subnet addresses must be unique.
- Highest MPI/PROFIBUS address ≥ physical MPI/PROFIBUS address, and must be identical for each node. (Exception: connecting a PG to multiple nodes; refer to the next chapter).

## Differences in the MPI addresses of CPs/FMs in an S7300 system

Table 4- 13 MPI addresses of CPs/FMs in an S7-300 system

Options	Example			
<p>Example: A system containing an S7-300 CPU and 2 CPs. You have two options of assigning MPI addresses to CPs/FMs installed in a system:</p>				
	CPU	CP	CP	SM
<b>1st option:</b> The CPU accepts the MPI addresses you set for the CPs in STEP 7.	MPI addr.	MPI addr.+x	MPI addr.+y	
<b>2nd option:</b> The CPU automatically assigns MPI addresses to the CPs in its system, based on the following syntax: MPI addr. CPU; MPI addr.+1; MPI addr.+2. (Default)	MPI addr.	MPI addr.+1	MPI addr.+2	
<b>Special feature: CPU 315-2 PN/DP, CPU 317 and CPU 319-3 DP/DP</b>	<p>When the central rack of an S7-300 contains FM/CPs with their own MPI address, the CPU forms its own communication bus via the backplane bus for these FM/CPs and separates it from the other subnets.</p> <p>The MPI address of those FM/CPs is thus no longer relevant for the nodes on other subnets. The MPI address of the CPU is used to communicate with these FMs/CPs.</p>			

### Recommendation for MPI addresses

Reserve MPI address "0" for a service PG, or "1" for a service OP, for temporary connections of these devices to the subnet. You should therefore assign different MPI addresses to PGs/OPs operating on the MPI subnet.

Recommended MPI address of the CPU for replacement or service operations:

Reserve MPI address "2" for the CPU. This prevents duplication of MPI addresses after you connect a CPU with default settings to the MPI subnet (for example, when replacing a CPU). That is, you should assign an MPI address greater than "2" to CPUs on the MPI subnet.

### Recommendation for PROFIBUS addresses

Reserve PROFIBUS address "0" for a service PG that you can subsequently connect briefly to the PROFIBUS subnet as required. You should therefore assign unique PROFIBUS addresses to PGs integrated in the PROFIBUS subnet.

### PROFIBUS DP: Electrical cables or fiber-optic cables?

Use fiber optic cables on a field bus with greater length, rather than copper conductors, in order to be independent on the transmission rate, and to exclude external interference.

### Equipotential bonding

For information on what to take into account with respect to equipotential bonding in your network configuration, refer to the corresponding chapter in the appendix.

### Reference

For further information, refer to the Communication section in *CPU 31xC and CPU 31x Manual, Technical Data*.

#### 4.11.2.3 Multi-Point Interface (MPI)

### Availability

All the CPUs described here are equipped with an MPI interface

A CPU equipped with an MPI/DP interface is configured and supplied as MPI interface.

### Properties

The MPI (Multi-Point Interface) represents the CPU interface for PG/OP connections, or for communication on an MPI subnet.

The default transmission rate of all CPUs is 187.5 kbps. You can also set 19.2 kbps for communication with an S7-200. The 315-2 PN/DP, 317-2 and 319-3 PN/DP CPUs support transmission rates to 12 Mbps.

The CPU automatically broadcasts its bus configuration via the MPI interface (the transmission rate, for example). A PG, for example, can thus receive the correct parameters and automatically connect to a MPI subnet.

### Devices capable of MPI communication

- PG/PC
- OP/TP
- S7-300 / S7-400 with MPI interface
- S7-200 (only at 19.2 kbps)

<b>NOTICE</b>
You may only connect PGs to an MPI subnet which is in RUN. Do not connect other stations (for example, OP, TP) to the MPI subnet while the system is running. Otherwise, transferred data might be corrupted as a result of interference, or global data packages may be lost.

## Clock synchronization

The CPU's MPI interface supports clock synchronization. The CPU can be programmed for operation as time-of-day master (with default synchronization intervals) or slave clock.

**Default setting:** No clock synchronization

The synchronization mode is set in the "Clock" tab of the CPU or interface properties dialog box in HW Config.

## CPU as a time slave

When operated as a slave clock, the CPU receives a synchronization message frame from exactly one time-of-day master and sets its internal time accordingly.

## CPU as a time master

When operated as time-of-day master, the CPU broadcasts clock synchronization message frames at programmed synchronization intervals at the MPI interface to other node stations of the MPI subnet.

**Condition:** The CPU real-time clock may no longer be in the default state. It has to be set once.

---

### Note

The real-time clock of the CPU is not yet set in the state of delivery or after resetting to the state of delivery using the mode selector or after a firmware update.

---

The clock synchronization starts as a time-of-day master:

- As soon as you have set the time the first time using SFC 0 "SET\_CLK" or the programming device function.
- By another time-of-day master if the CPU is also parameterized as a slave clock using the MPI/DP or PROFINET interface.

## Interfaces for clock synchronization

Clock synchronization is possible at the following interfaces:

- At the MPI Interface
- At the DP Interface
- At the PROFINET Interface
- In the automation system of the central configuration

---

### Note

The CPU may only be operated as time slave at one of these interfaces.

---

**Example 1**

A CPU operating as a slave clock on the DP interface can only operate as a time-of-day master on the MPI interface and/or within the automation system.

**Example 2**

If the CPU time is already synchronized through clock synchronization by means of a PROFINET interface via NTP (corresponds to the functionality as a slave clock), the CPU can only be operated as a time-of-day master at the DP interface and/or the MPI interface within the automation system.

**4.11.2.4 PROFIBUS DP interface**

**Availability**

CPUs with the "DP" have at least one DP interface.

The 315-2 PN/DP and 317-2 PN/DP CPUs feature an integrated MPI/DP interface. The 317-2 DP and 319-3 PN/DP CPUs feature an MPI/DP interface plus an additional DP interface. The factory setting of the CPU's MPI/DP interface is MPI mode. You need to set DP mode in STEP 7 if you want to use the DP interface.

**Operating modes for CPUs with two DP interfaces**

Table 4- 14 Operating modes for CPUs with two DP interfaces

MPI/DP interface	PROFIBUS DP interface
<ul style="list-style-type: none"> <li>• MPI</li> <li>• DP master</li> <li>• DP slave <sup>1)</sup></li> </ul>	<ul style="list-style-type: none"> <li>• not configured</li> <li>• DP master</li> <li>• DP slave <sup>1)</sup></li> </ul>

<sup>1)</sup> simultaneous operation of the DP slave on both interfaces is excluded

**Properties**

The PROFIBUS DP interface is mainly used to connect distributed I/O. PROFIBUS DP allows you to create large subnets, for example.

The PROFIBUS DP interface can be set for operation in master or slave mode, and supports transmission rates up to 12 Mbps.

The CPU broadcasts its bus parameters (transmission rate, for example) via the PROFIBUS DP interface when master mode is set. This functionality automatically provides the correct parameters for online operation of a programming device, for example. In your configuration you can specify to disable bus parameter broadcasting.



---

**Note**

**(for DP interface in slave mode only)**

When you disable the "Test, Commissioning, Routing" check box in the DP interface properties dialog box in STEP 7, the transmission rate settings of the master automatically override corresponding user-specific settings. This disables the routing function at this interface.

---

**Devices capable of PROFIBUS DP communication**

- PG/PC
- OP/TP
- DP slaves
- DP master
- Actuators/Sensors
- S7-300/S7-400 with PROFIBUS DP interface

**Clock synchronization**

The CPU's DP interface supports clock synchronization. The CPU can be programmed for operation as time master (with default synchronization intervals) or time slave.

**Default setting:** No clock synchronization

The synchronization mode is set in the "Clock" tab of the interface properties dialog box in HW Config.

**CPU as a time slave**

When operated as a slave clock, the CPU receives a synchronization message frame from exactly one time-of-day master and sets its internal time accordingly.

### CPU as a time master

When operated as time-of-day master, the CPU broadcasts clock synchronization message frames at programmed synchronization intervals at the DP interface to other node stations of the DP subnet.

**Condition:** The CPU real-time clock may no longer be in the default state. It has to be set once.

---

#### Note

The real-time clock of the CPU is not yet set in the state of delivery or after resetting to the state of delivery using the mode selector or after a firmware update.

---

The clock synchronization starts as a time-of-day master:

- As soon as you have set the time the first time using SFC 0 "SET\_CLK" or the programming device function.
- By another time-of-day master if the CPU is also parameterized as a slave clock using the MPI/DP or PROFINET interface.

### Interfaces for clock synchronization

Clock synchronization is possible at the following interfaces:

- At the MPI Interface
- At the DP Interface
- At the PROFINET Interface
- In the automation system of the central configuration

---

#### Note

The CPU may only be operated as a slave clock at one of these interfaces.

---

### Example 1

A CPU operating as a slave clock on the DP interface can only operate as a time-of-day master on the MPI interface and/or within the automation system.

### Example 2

If the CPU time is already synchronized through clock synchronization by means of a PROFINET interface via NTP (corresponds to the functionality as a slave clock), the CPU can only be operated as a time-of-day master at the DP interface and/or the MPI interface within the automation system.

### Reference

Further information on the PROFIBUS can be found on the Internet.

### 4.11.2.5 Network components of MPI/DP and cable lengths

#### MPI subnet segment

You can install cables with a length of up to 50 m in an MPI subnet segment. This length of 50 m is the distance between the first and the last node of the segment.

Table 4- 15 Permissible cable length of a segment on the MPI subnet

Baud rate	S7-300 CPUs (non-isolated MPI interface) without CPU 315-2 PN/DP / CPU 317 / CPU 319	CPU 315-2 PN/DP / CPU 317 / CPU 319
19.2 kbps	50 m	1000 m
187.5 kbps		
1.5 Mbps	-	200 m
3.0 Mbps		100 m
6.0 Mbps		
12.0 Mbps		

#### Segment on the PROFIBUS subnet

The maximum cable length of a segment on the PROFIBUS subnet is determined by the set transmission rate.

Table 4- 16 Permissible cable length of a segment on the PROFIBUS subnet

Baud rate	Maximum cable length of a segment
9.6 kbps to 187.5 kbps	1000 m
500 kbps	400 m
1.5 Mbps	200 m
3 Mbps to 12 Mbps	100 m

#### Longer cable lengths via RS 485 Repeater / RS 485-Diagnostics Repeater

You need to install RS485 repeaters for segments requiring cable lengths longer than the allowed length. For further information about the RS485 Repeater refer to the *Module Specifications Manual*.

#### Stub cables

Make allowances for the maximum stub cable length when you connect bus nodes to a segment by means of stub cables, for example, a PG via standard PG cable.

For transmission rates up to 3 Mbps, you can use a PROFIBUS bus cable with bus connector as stub cable. For transmission rates higher than 3 Mbps, use the patch cord to connect the PG or PC. You can connect several PG patch cords to the bus (for order numbers see table 4-20). Other types of stub cables are not permitted.

**Length of stub cables**

The table below shows the maximum permitted lengths of stub cables per segment:

Table 4- 17 Lengths of stub cables per segment

Baud rate	Max. length of stub cables per segment	Number of nodes with stub cable length of ...	
		1.5 m or 1.6 m	3 m
9.6 kbps to 93.75 kbps	96 m	32	32
187.5 kbps	75 m	32	25
500 kbps	30 m	20	10
1.5 Mbps	10 m	6	3
3 Mbps to 12 Mbps	1)	1)	1)

1) To connect PGs or PCs when operating at rates higher than 3 Mbps, use PG connecting cables with the order number 6ES7 901-4BD00-0XA0. In your bus configuration, you can use multiple PG patch cords with this order number. Other types of stub cables are not permitted.

**PG connecting cable**

Table 4- 18 PG connecting cable

Type	Order No.
PG connecting cable	6ES7 901-4BD00-0XA0

**PROFIBUS cables**

For PROFIBUS DP or MPI networking we offer you the following bus cables for diverse fields of application:

Table 4- 19 Available bus cables

Bus cable	Order No.
PROFIBUS cable	6XV1 830-0AH10
PROFIBUS cable, halogen-free	6XV1 830-0LH10
PROFIBUS underground cable	6XV1 830-3AH10
PROFIBUS trailing cable	6XV1 830-3BH10
PROFIBUS cable with PUR sheath for environments subject to chemical and mechanical stress	6XV1 830-0DH10
PROFIBUS cable with PE sheath for the food and beverages industry	6XV1 830-0BH10
PROFIBUS cable for festooning	6XV1 830-3CH10

## Properties of PROFIBUS cables

The PROFIBUS bus cable is a 2-wire, shielded twisted-pair cable with copper conductors. It is used for hardwired transmission in accordance with US Standard EIA RS485.

The table below lists the characteristics of these bus cables.

Table 4- 20 Properties of PROFIBUS bus cables

Properties	Values
Wave impedance	approx. 135 Ω to 160 Ω (f = 3 MHz to 20 MHz)
Loop resistance	≤ 115 Ω/km
Effective capacitance	30 nF/km
Attenuation	0.9 dB/100 m (f = 200 kHz)
Permitted conductor cross-sections	0.3 mm <sup>2</sup> to 0.5 mm <sup>2</sup>
Permitted cable diameter	8 mm ± 0.5 mm

## Installation of bus cables

When you install PROFIBUS bus cables, you must not

- twist,
- stretch
- or compress them.

When wiring indoor bus cables, also maintain the following marginal conditions (d<sub>A</sub> = outer cable diameter):

Table 4- 21 Marginal conditions for wiring interior bus cables

Characteristics	Condition
Bending radius (one-off)	≥ 80 mm (10 x d <sub>A</sub> )
Bending radius (multiple times)	≥ 160 mm (20 x d <sub>A</sub> )
Permitted temperature range during installation	-5 °C to +50 °C
Shelf and static operating temperature range	-30 °C to +65 °C (-22 °F to +149 °F)

## Reference

For information on the use of fiber-optic cables for PROFIBUS, refer to the SIMATIC NET, PROFIBUS Networks Manual.

**Bus connector RS 485**

Table 4- 22 Bus connector

Type	Order No.
Bus connector RS 485 up to 12 Mbaud with 90° cable exit without programming device interface with programming device interface	6ES7 972-0BA11-0XA0 6ES7 972-0BB11-0XA0
Fast connect bus connector RS 485 up to 12 Mbaud with 90° cable exit in insulation displacement technique without programming device interface with programming device interface	6ES7 972-0BA50-0XA0 6ES7 972-0BB50-0XA0
Bus connector RS 485 up to 12 Mbaud with 35° cable exit (not for CPU 31xC, 312, 314 and 315-2 DP) with programming device interface with programming device interface	6ES7 972-0BA40-0XA0 6ES7 972-0BB40-0XA0

**Field of application**

You need bus connectors to connect the PROFIBUS bus cable to an MPI or PROFIBUS-DP interface

You do not require a bus connector for:

- DP slaves with degree of protection IP 65 (ET 200pro, for example)
- RS 485 repeater.

**RS485 Repeater 485**

Type	Order No.
RS 485 repeater	6ES7 972-0AA01-0XA0
RS 485 Diagnostic Repeater	6ES7 972-0AB01-0XA0

**Note**

SFC 103 "DP\_TOPOL" can be used to initiate identification of the bus topology of a DP master system by way of the interconnected diagnostic repeaters.

**Purpose**

RS485 repeaters are used to amplify data signals on bus lines and to couple bus segments.

You require this RS 485 Repeater in the following situations:

- more than 32 network nodes
- when interconnecting a grounded with an ungrounded segment
- when exceeding the maximum line length in a segment

### **Longer cable lengths**

If you want to implement cable lengths above those permitted in a segment, you must use RS485 repeaters. The maximum cable length between two RS 485 repeaters corresponds to the maximum cable length of a segment. Please note that these maximum cable lengths only apply if there is no further node interconnected between the two RS 485 repeaters. You can connect up to nine RS 485 repeaters in series. Please note that you have to add the RS 485 repeater when you determine the number of nodes in your subnet, even if it is not assigned its own MPI/PROFIBUS address.

### **Reference**

For further information about the RS485 Repeater, refer to the *Module Specifications Manual*.

4.11.2.6 Cable lengths of MPI and PROFIBUS subnets

Example: Installation of an MPI subnet

The figure below shows you the block diagram of a MPI subnet.

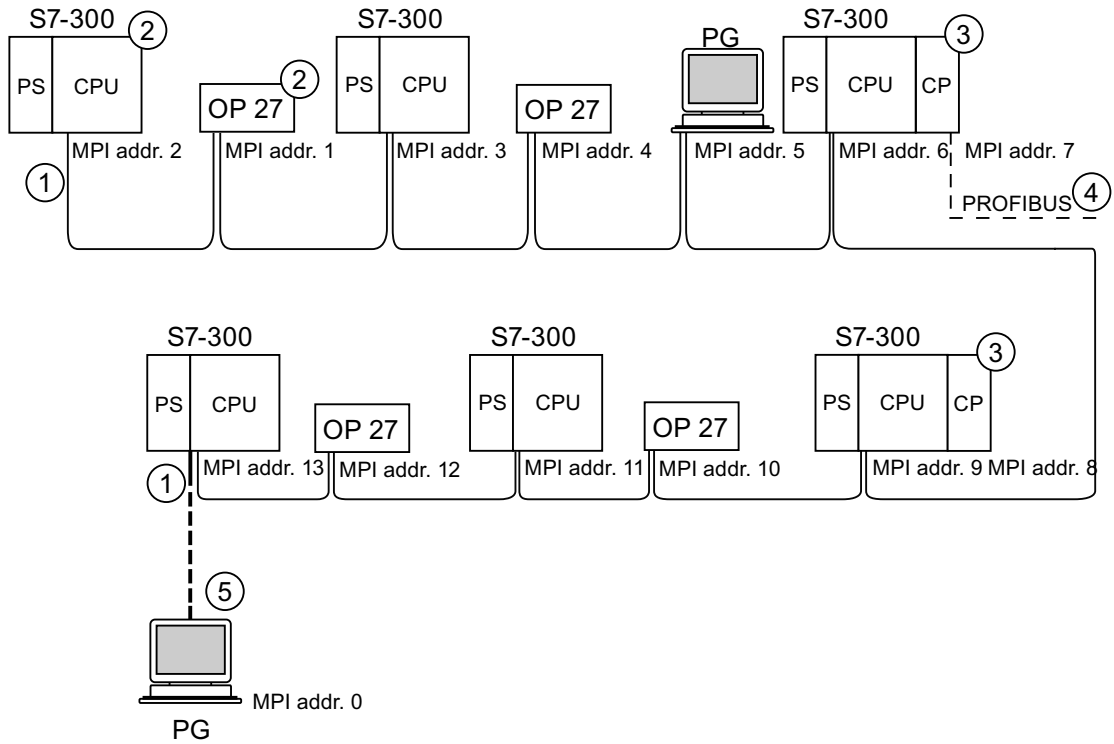

- | Number | Identifier   |
|--------|--|
| ①      | Terminating resistor enabled.  |
| ②      | S7-300 and OP 27 have subsequently been connected to the MPI subnet using their default MPI address.   |
| ③      | CPU 31xC, 312, 314, 315-2 DP:<br>You can also assign user-specific MPI addresses to the CPs/FMs at these CPUs.<br>CPU 317-2 DP, 315-2 PN/DP, 317-2 PN/DP, 319-3 PN/DP:<br>CPs and FMs do not have their own MPI address on this CPU. |
| ④      | In addition to the MPI address, the CP also has a PROFIBUS address (7 in this case).   |
| ⑤      | Connected via stub cable using the default MPI address only for commissioning/maintenance.   |

Example: Maximum distances in the MPI subnet

The figure below shows you:

- a possible MPI subnet configuration
- maximum distances possible in an MPI subnet
- the principle of "Line extension" using RS 485 repeaters



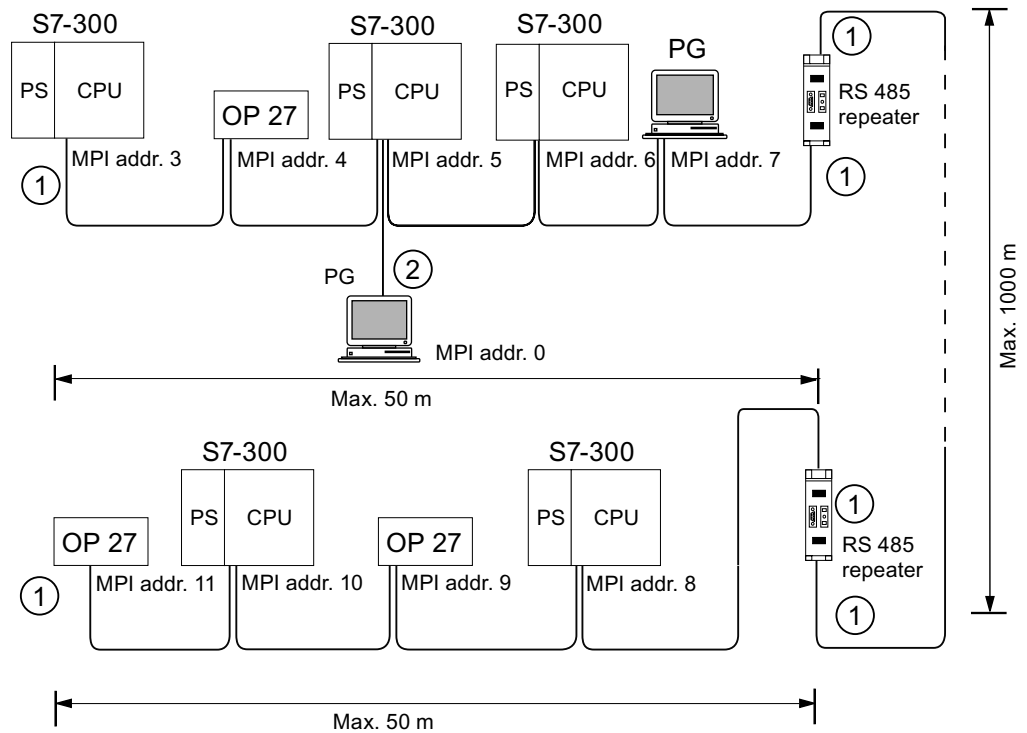

**Number Identifier**

- ① Terminating resistor enabled.
- ② PG connected by means of a stub cable for maintenance purposes

### Example: Terminating resistor in the MPI subnet

The figure below shows you an example of an MPI subnet and where to enable the terminating resistor.

The figure below illustrates where the terminating resistors must be enabled in an MPI subnet. In this example, the programming device is connected via a stub cable only for the duration of commissioning or maintenance.

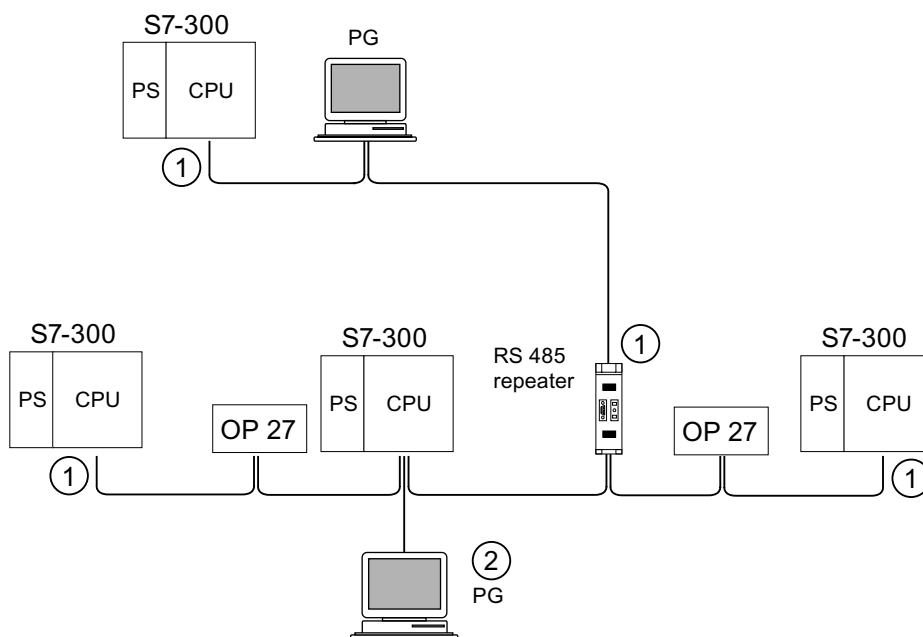

**Number Identifier**

- ① Terminating resistor enabled.
- ② PG connected by means of a stub cable for maintenance purposes

**⚠ WARNING**

Disturbance of data traffic might occur on the bus. A bus segment must always be terminated at both ends with the terminating resistor. This, for example, is not the case if the last slave with bus connector is off power. The bus connector draws its power from the station, and the terminating resistor is thus disabled. Please make sure that power is always supplied to stations on which the terminating resistor is active. Alternatively, the PROFIBUS terminator can also be used as active bus termination.

### Example: Installation of a PROFIBUS subnet

The figure below shows you the basic principles of a PROFIBUS subnet installation.

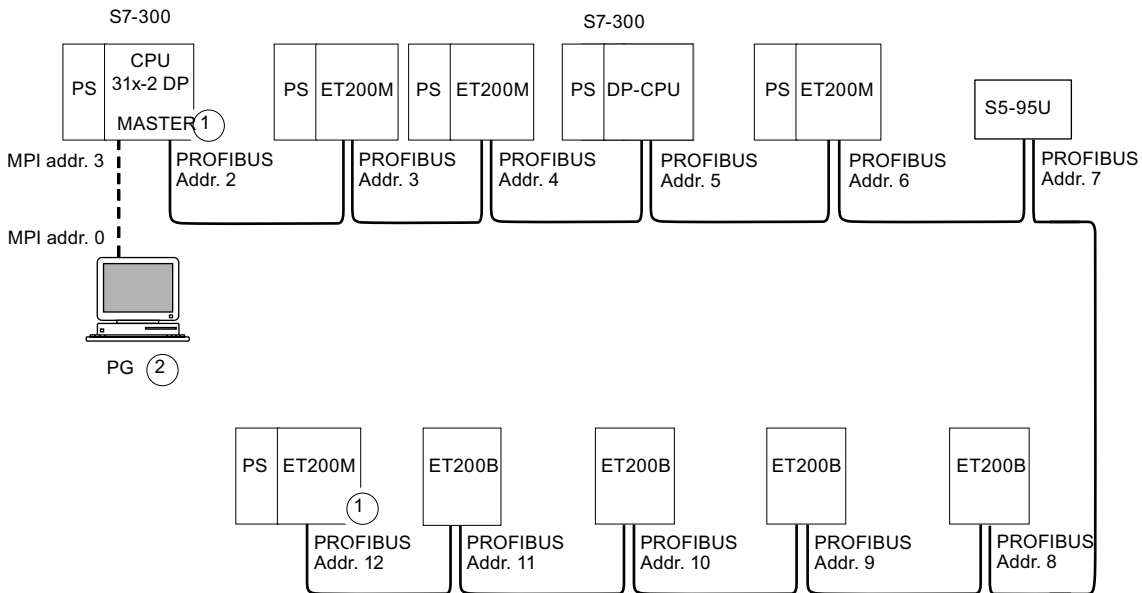

**Number Identifier**

- ① Terminating resistor enabled.
- ② PG connected by means of stub cable for maintenance purposes

**Example: CPU 314C-2 DP as MPI and PROFIBUS node.**

The figure below shows you an assembly with a CPU 314C-2 DP integrated in an MPI subnet and also operated as DP master in a PROFIBUS subnet.

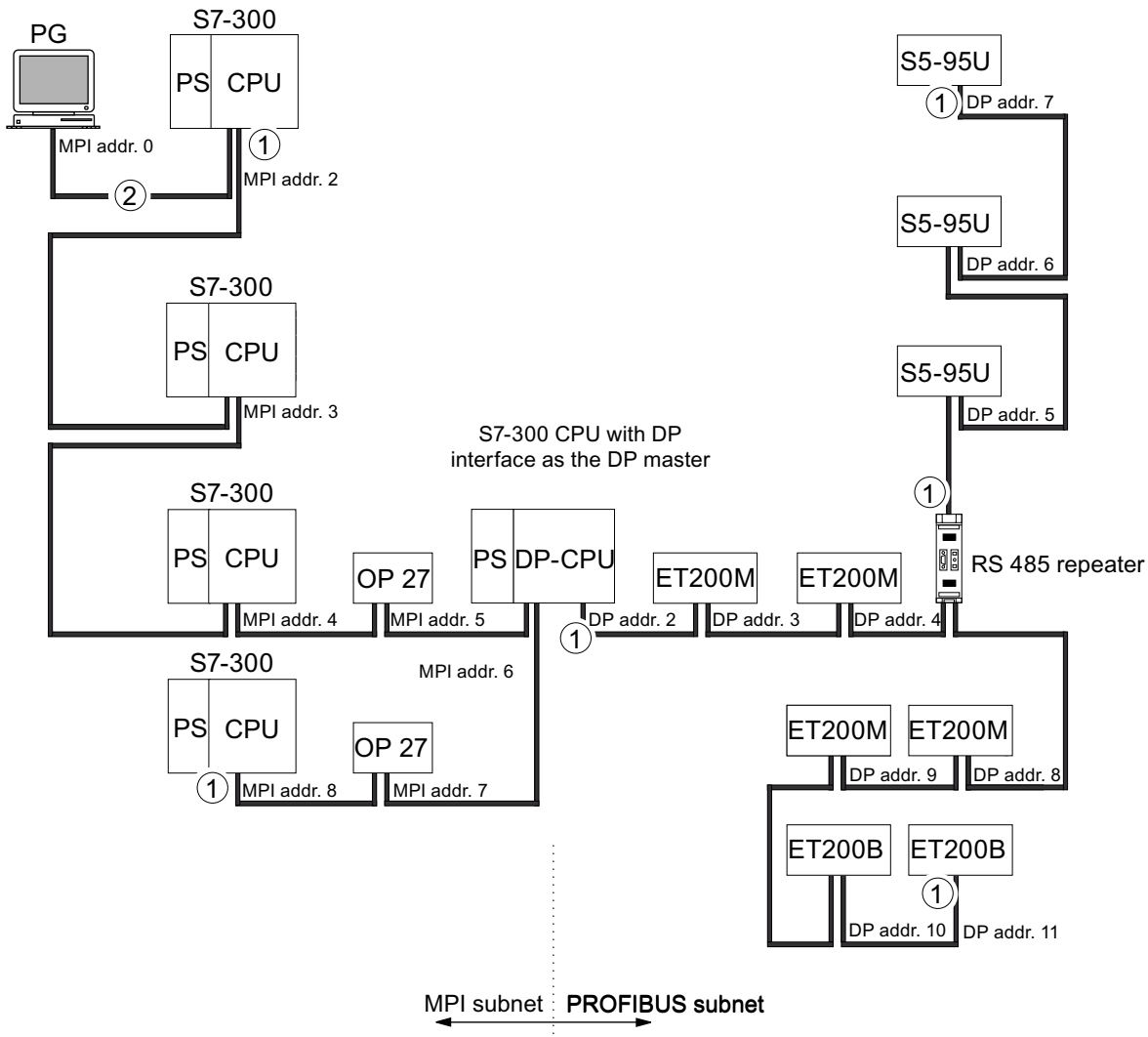

- | Number | Identifier  |
|--------|---|
| ①      | Terminating resistor enabled.   |
| ②      | PG connected via a stub cable for maintenance or commissioning purposes |

### 4.11.3 Configuring PROFINET subnets

#### 4.11.3.1 Overview

The next section contains all the information you require to configure PROFINET subnets:

#### Contents

- PROFINET nodes
- Integration of field bus system into PROFINET
- PROFINET IO and PROFINET CBA (Component-Based Automation)
- PROFINET cable lengths
- Ethernet bus cable and connector
- Example of a PROFINET subnet
- Example of a PROFINET IO system

#### 4.11.3.2 PROFINET devices

##### **Definition: Devices in the PROFINET environment**

Within the context of PROFINET, "device" is the generic term for:

- Automation systems (e.g. PLC, PC)
- Field devices (for example, PLC, PC, hydraulic devices, pneumatic devices)
- Active network components (e.g. switches, gateways, routers)
- PROFIBUS or other fieldbus systems

The main characteristics of a device is its integration into PROFINET communication by means of Ethernet or PROFIBUS.

The following device types are distinguished based on their attachment to the bus:

- PROFINET devices
- PROFIBUS devices

**Definition: PROFINET devices**

A PROFINET device always has at least one Industrial Ethernet port. A PROFINET device can also have a PROFIBUS port, that is, as master with proxy functionality.

**Definition: PROFIBUS devices**

A PROFIBUS device has at least one PROFIBUS link with an electric interface (RS485) or an optical interface (polymer optical fiber, POF).

A PROFIBUS device cannot take part directly in PROFINET communication, but must be implemented by means of PROFIBUS master with PROFINET link or Industrial Ethernet/PROFIBUS link (IE/PB Link) with proxy functionality.

### Comparison of the terminology in PROFIBUS DP and PROFINET IO

The following schematic shows you the general names of the most important devices in PROFINET IO and PROFIBUS DP. The table below shows the designation of the various components in the PROFINET IO and PROFIBUS DP context.

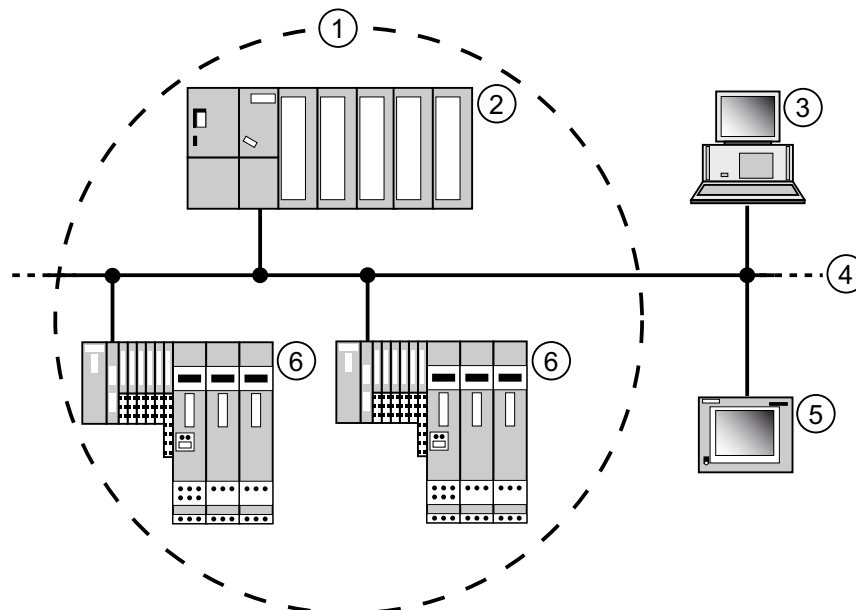

Number	PROFINET	PROFIBUS	Remark
①	IO system	DP master system	
②	IO controller	DP master	Device used to address the connected IO devices/DP slaves. That is: The IO controller/DP master exchanges input and output signals with field devices. The IO controller/DP master is often the controller on which the automation program runs.
③	PD/PC (IO supervisor)	PG/PC (Class 2 DP master)	PG/PC/HMI device for commissioning and diagnostics
④	Industrial Ethernet	PROFIBUS	Network infrastructure
⑤	HMI (Human Machine Interface)	HMI	Device for operating and monitoring functions.
⑥	IO device	DP slave	Distributed field device assigned to one of the IO controllers/DP masters, for example, distributed IO, valve terminal, frequency converter, and switches with integrated PROFINET IO functionality.

Figure 4-3 PROFINET and PROFIBUS devices

### Slots and Submodules

A PROFINET IO device is modularly structured - similar to a PROFIBUS DP slave.

In doing so, modules are fitted to slots and submodules to subslots. Channels are located on the modules / submodules using which process signals can be read in and issued.

The following graphic illustrates the situation.

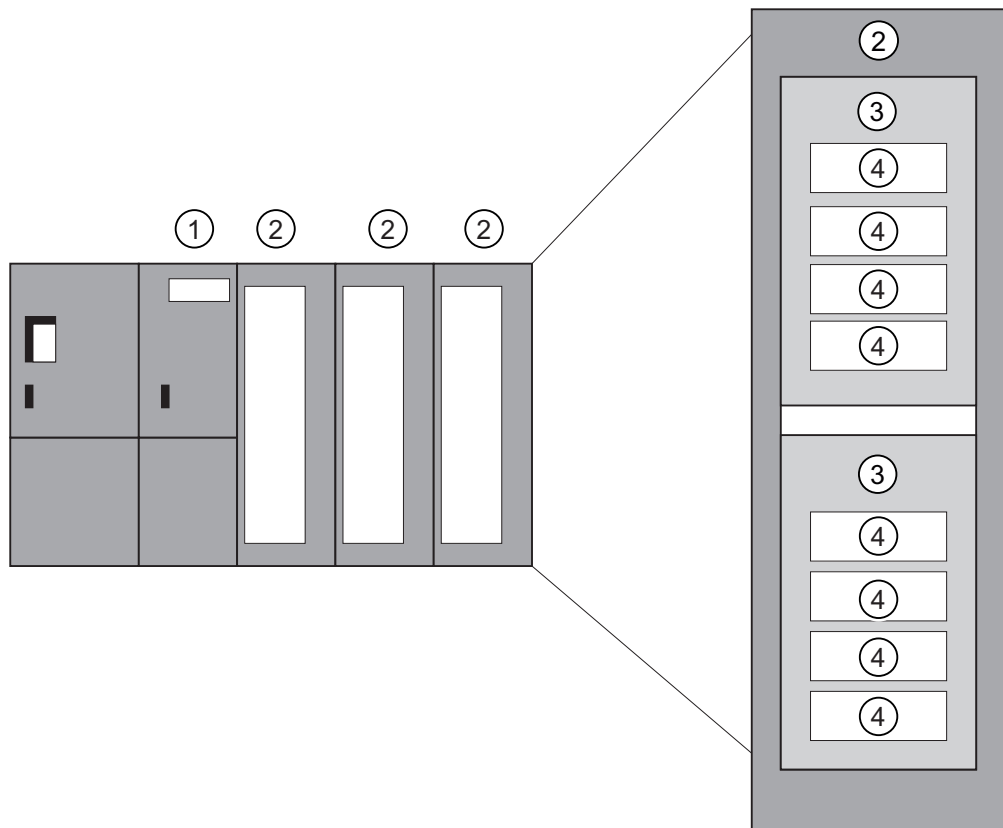

Figure 4-4 Module, Submodule, Slot, and Channel

Number	Description
①	Interface module
②	Module with components
③	Submodule
④	Channel

In principle it is possible to divide a slot into additional subslots on which the submodules are connected.



### 4.11.3.3 Integration of fieldbuses into PROFINET

#### Fieldbus integration

PROFINET allows you to use a proxy to integrate existing fieldbus systems (for example, PROFIBUS, ASI) into PROFINET. In this way, you can set up hybrid systems consisting of fieldbus and Ethernet-based subsystems. A continuous technological transition to PROFINET is thus possible.

#### Interconnecting PROFINET and PROFIBUS

You can interconnect PROFIBUS devices to the local PROFIBUS interface of a PROFINET device. This allows you to integrate existing PROFIBUS configurations in PROFINET.

The following picture illustrates the network types that are supported for PROFINET:

- Industrial Ethernet and
- PROFIBUS.

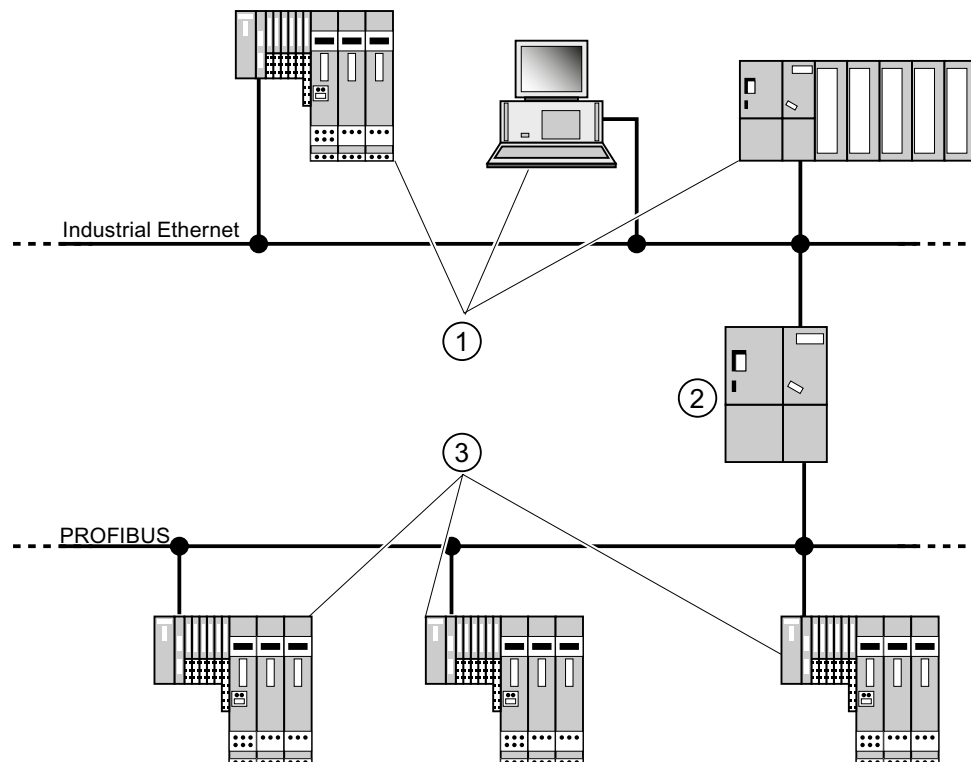

Figure 4-5 PROFINET devices, PROFIBUS devices, and proxy

Number	Description
①	PROFINET devices
②	PROFINET device with proxy functionality
③	PROFIBUS devices

### PROFINET device with proxy functionality = substitute

The PROFINET device with proxy functionality is the substitute for a PROFIBUS device on Ethernet. The proxy functionality allows a PROFIBUS device to communicate not only with its master but also with all nodes on PROFINET.

With PROFINET, existing PROFIBUS systems can be integrated into the PROFINET communication with the aid of an IE/PB link, for example. The IE/PB link then handles communication via PROFINET on behalf of the PROFIBUS components.

In this way, you can link both DPV0 and DPV1 slaves to PROFINET.

### Further information

For information on the differences and common features of PROFINET IO and PROFIBUS DP and information on migrating from PROFIBUS DP to PROFIBUS IO, refer to the *From PROFIBUS DP to PROFINET IO* programming manual.

#### 4.11.3.4 PROFINET IO and PROFINET CBA

### What is PROFINET IO?

As part of PROFINET, PROFINET IO is a communication concept that is used to implement modular, distributed applications.

PROFINET IO allows you to create automation solutions, which are familiar to you from PROFIBUS.

PROFINET IO is implemented using the PROFINET standard for programmable controllers.

The STEP 7 engineering tool helps you to structure and configure an automation solution.

In STEP 7 you have the same application view, regardless of whether you are configuring PROFINET devices or PROFIBUS devices. You will program your user program in the same way for both PROFINET IO and PROFIBUS DP since you will use the extended blocks and system status lists for PROFINET IO.

### Reference

Information on new and modified blocks and system status lists can be found in the *From PROFIBUS DP to PROFINET IO* programming manual.

## What is PROFINET CBA?

As part of PROFINET, PROFINET CBA (Component Based Automation) is an automation concept that focuses on the following:

- Implementation of modular applications
- Machine - machine communication

PROFINET CBA lets you create distributed automation solutions, based on default components and partial solutions. This concept meets the demand for a greater modularity in the field of mechanical and systems engineering by extensive distribution of intelligent processes.

With Component Based Automation you can implement complete technological modules as standardized components that can be used in large systems.

You create the modular, intelligent components of the PROFINET CBA in an engineering tool (which may differ according to the device manufacturer). Components that are formed from SIMATIC devices are created with STEP 7, and are interconnected using the SIMATIC iMAP tool.

**Interaction between PROFINET IO and PROFINET CBA**

PROFINET CBA is used to integrate PROFINET IO systems into machine-to-machine communication. A PROFINET component is created from a PROFINET IO system in STEP 7, for example. With SIMATIC iMap, you can configure systems consisting of several such components. The communication connections between the devices are configured simply as interconnection lines.

The following graphic illustrates a distributed automation solution with several components which communicate via PROFINET. The components on the right have IO devices and an IO controller on PROFINET IO.

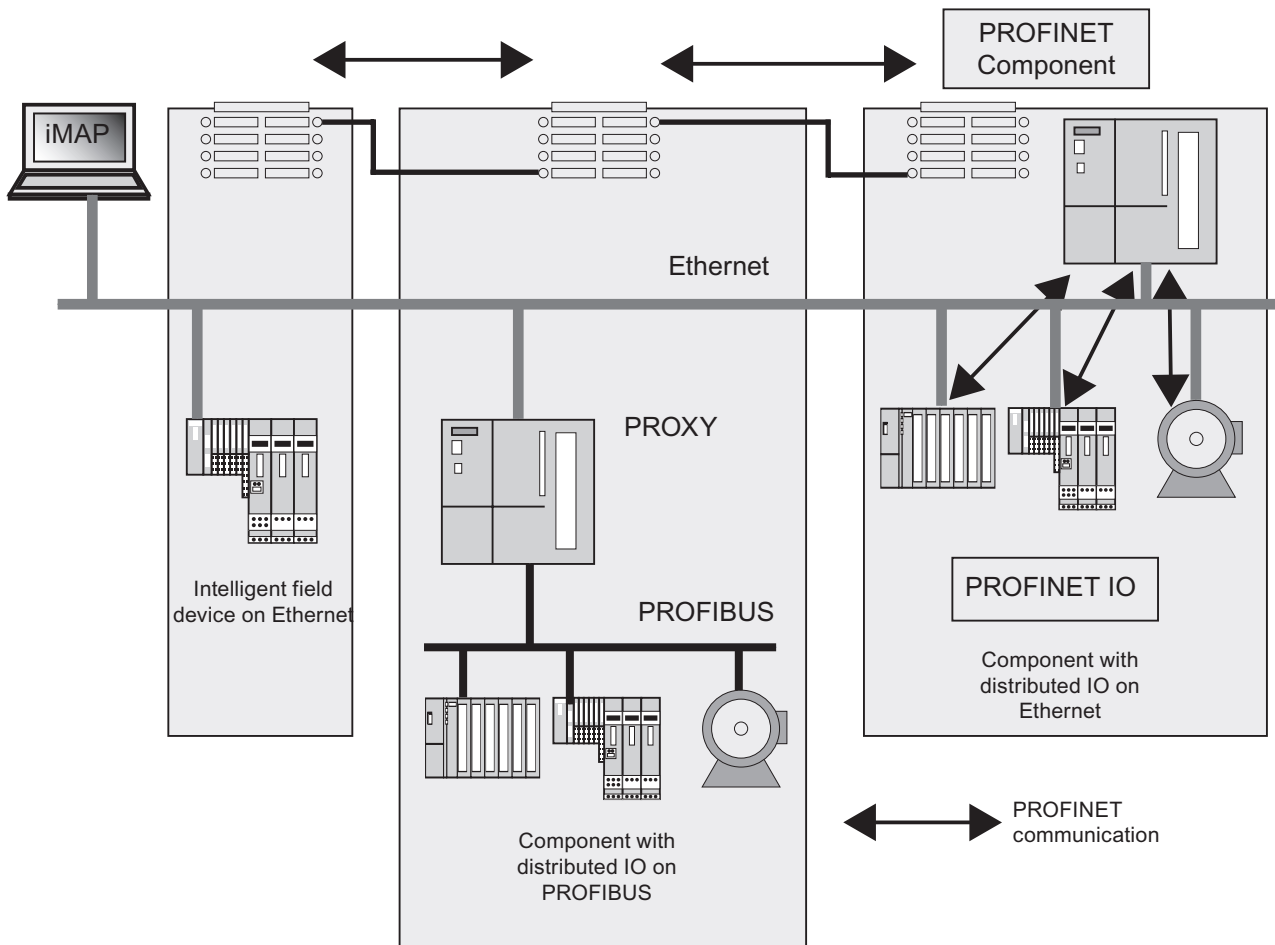

Figure 4-6 PROFINET CBA - modular concept

### Extent of PROFINET CBA and PROFINET IO

PROFINET IO and CBA represent two different views of automation devices on Industrial Ethernet.

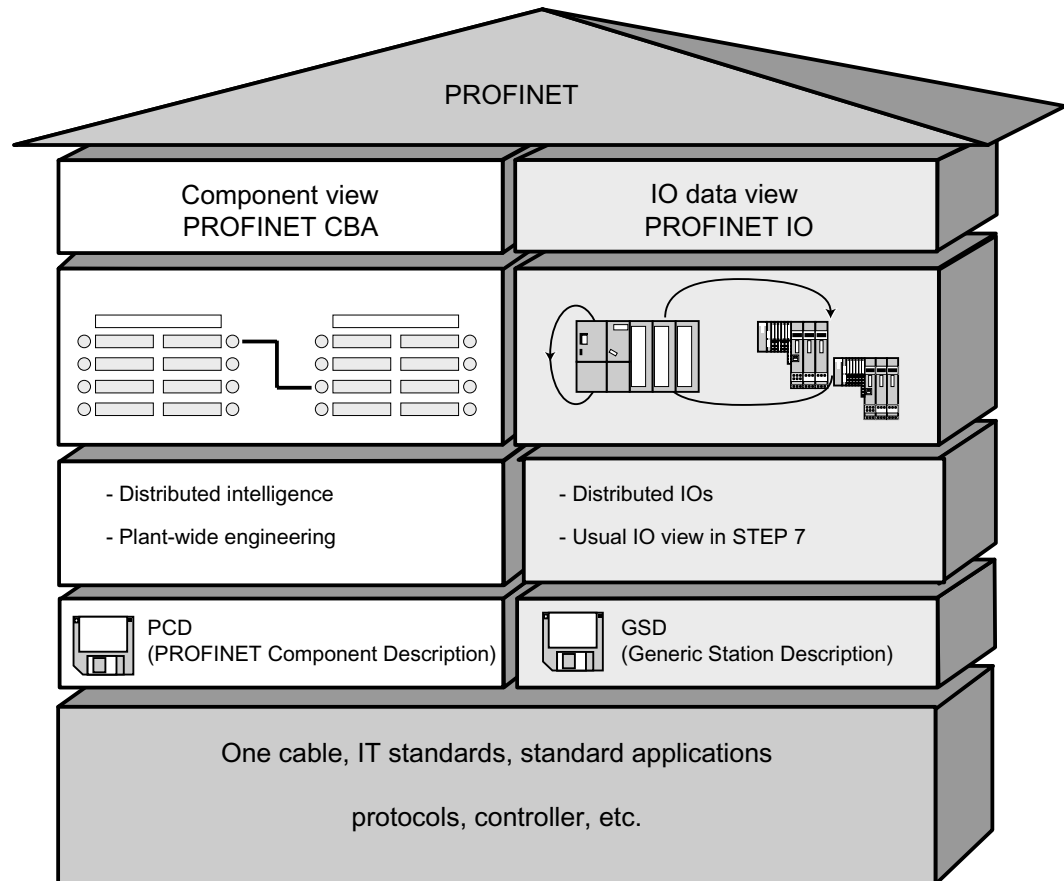

Figure 4-7 Extent of PROFINET CBA and PROFINET IO

Component Based Automation divides the entire system into various functions. These functions are configured and programmed.

PROFINET IO provides an image of the system that is very similar to the view obtained in PROFIBUS. You continue to configure and program the individual automation devices.

## Controllers in PROFINET IO and PROFINET CBA

You can also use some PROFINET IO controllers for PROFINET CBA.

The following PROFINET devices act as a **PROFINET CBA or IO controller**:

- Programmable logic controllers,
  - S7-300 CPU 31x-2 PN/DP, firmware version V2.3 or later
  - S7-300 CPU 319-3 PN/DP, firmware version V2.4.0 or later
- CP 343-1 - version 6GK7 343-1EX21-0XE0 and 6GK7 343-1GX21-0XE0 or later
- CP 443-1 Advanced with MLFB 6GK7 443-1EX40 version V2.1 and 6GK7 443-1EX41 version V1.0 or later.

The following PROFINET devices can only act as a **PROFINET IO controller**:

- PCs that are linked to a PROFINET IO-compatible CP (CP 1616 for example) or via SOFTNET PN IO (with CP 1612 for example). With the CP 1616 and SOFTNET PN IO, the user program runs in the CPU of the PC.
- SIMOTION devices for particularly stringent real-time requirements.

Some PROFINET devices can only be used as **PROFINET CBA controllers**, for example, PCs with standard Ethernet interfaces and the WinLC software.

CP443-1 EX 40 V2.1 or later or CP443-1 EX41 V 1.0 or later

## Proxy in PROFINET IO and PROFINET CBA

The proxies for PROFINET IO and proxies for PROFINET CBA are different.

In PROFINET IO, the proxy for PROFINET IO represents each connected PROFIBUS DP slave as a **PROFINET IO device** on the PROFINET.

In PROFINET CBA, the proxy for PROFINET CBA represents every connected PROFIBUS DP slave as one **component**, which can participate in PROFINET communication.

There are thus different IE/PB links for PROFINET IO and PROFINET CBA, for example. At present you can currently only use a CPU 31x PN/DP as a proxy for PROFINET CBA.

## Linking PROFIBUS devices via an IE/PB link

Please note that proxy functionality is available in both PROFINET IO and PROFINET CBA. For the IE/PB link, this means that you must use different devices depending on the system you are using.

## Configuring and integrating components and devices in PROFINET communication

In Component Based Automation, an interconnection editor is used to incorporate the components (SIMATIC iMap for example). The components are described in a PCD file.

With PROFINET IO, the devices are incorporated using an engineering system (STEP 7 for example). The devices are described in a GSD file.

## Interaction between PROFINET CBA and PROFINET IO

PROFINET IO integrates field devices (IO devices) into PROFINET. The input and output data of the IO devices are processed in the user program. The IO devices with their IO controller can, in turn, be part of a component in a distributed automation structure.

Communication between a CPU as the IO controller and the assigned IO devices as PROFINET IOs is configured in the same way as for a PROFIBUS DP master system in STEP 7. The user program is also created in STEP 7. From the entire PN IO system, you create a component in STEP 7 (see Figure PROFINET CBA).

You then configure communication between the components in user-friendly SIMATIC iMAP.

## Update time

The IO controller (outputs) provides new data to all IO devices in the PROFINET IO system within the update time. This means that all the IO devices have sent their latest data to the IO controller (inputs).

---

### Note

#### Send Cycles for Cyclical Data Exchange

STEP 7 determines the update time on the basis of the existing hardware configuration and the resulting cyclical data traffic. During this time, a PROFINET IO device has exchanged its user data with the associated IO controller.

You can set the update date either for a whole bus segment of an IO controller, or for an individual IO device.

In STEP 7, the update time can be changed manually.

The smallest possible update time in a PROFINET system depends on the following factors:

- Number of PROFINET IO devices
- Quantity of configured user data
- Volume of PROFINET IO communication traffic (compared to the volume of PROFINET CBA communication traffic)

#### Additional cyclical PROFINET services

The update time dialog in STEP 7/HW Config is used to set an update date for the device to be reserved for PROFINET IO.

See the STEP 7 Online Help for more information.

---

## Send clock

Period between two successive intervals for IRT or RT communication. The send clock is the shortest possible transmit interval for exchanging data. The calculated update times are multiples of the send clock.

The minimum possible update time thus depends on the minimum send clock of the IO controller that can be set.

If both the IO controller and the IO device support a send clock of 250  $\mu$ s, you can achieve a minimum update time of 250  $\mu$ s.

It is also possible to operate IO devices that only support a send clock of 1 ms on an IO controller that works with a send clock of 250  $\mu$ s. The minimum update time for the IO devices concerned is then at least 1 ms, however.

### Update times of CPU 319-3 PN/DP

Programmable update times when using CPU 319-3 PN/DP:

Send clock	Update time
250 $\mu$ s	⇒ 250 $\mu$ s to 128 ms
500 $\mu$ s	⇒ 500 $\mu$ s to 256 ms
1 ms	⇒ 1 ms to 512 ms

The minimum update time depends on the number of IO devices used, and on the volume of configured user data, and on the load in PROFINET IO communication. *STEP 7* automatically considers these dependencies during configuration.

### Details of the possible uses of the individual products

See also the documentation for the product concerned.

#### 4.11.3.5 PROFINET cable lengths and network expansion

Network expansion options are based on various factors (hardware design used, signal propagation delay, minimum distance between data packets, etc.)

#### Twisted-pair patch cables

TP Cords are used to interconnect terminal devices with the Industrial Ethernet FC cabling system. It is designed for use in environments with low EMC load, for example, in offices or in control cabinets.

The length of twisted-pair cords between two devices may not exceed 10 m.

Compared to Industrial Ethernet twisted-pair cables, the TP cords are significantly thinner and more flexible due to the reduced effort for their shielding. The connectors used in connecting industrial twisted-pair components are standardized RJ45 connectors and sub D connectors.



## Product range

Twisted-pair patch cords available:

Table 4- 23 Data for twisted-pair patch cables

Cable designation	Application	Available lengths	Order number
TP Cord RJ45/RJ45	TP connecting cable with two RJ45 connectors	0.5 m	6XV1 850-2GE50
		1.0 m	6XV1 850-2GH10
		2.0 m	6XV1 850-2GH20
		6.0 m	6XV1 850-2GH60
		10.0 m	6XV1 850-2GN10
TP XP cord RJ45/RJ45	TP crossover cable with two RJ45 connectors	0.5 m	6XV1 850-2HE50
		1.0 m	6XV1 850-2HH10
		2.0 m	6XV1 850-2HH20
		6.0 m	6XV1 850-2HH60
		10.0 m	6XV1 850-2HN10
TP cord 9/RJ45	TP patch cable with 9-pin sub-D connector and RJ45 connector	0.5 m	6XV1 850-2JE50
		1.0 m	6XV1 850-2JH10
		2.0 m	6XV1 850-2JH20
		6.0 m	6XV1 850-2JH60
		10.0 m	6XV1 850-2JN10
TP XP cord 9/RJ45	Crossover TP patch cable with 9-pin sub-D connector and RJ45 connector.	0.5 m	6XV1 850-2ME50
		1.0 m	6XV1 850-2MH10
		2.0 m	6XV1 850-2MH20
		6.0 m	6XV1 850-2MH60
		10.0 m	6XV1 850-2MN10
TP patch cable 9-45/RJ45	TP patch cable with RJ45 connector and sub-D connector, 45° cable exit (only for OSM/ESM)	1.0 m	6XV1 850-2NH10
TP XP patch cable 9-45/RJ45	Cross-over TP patch cable with RJ45 connector and sub-D connector with 45° cable exit (for OSM/ESM only)	1.0 m	6XV1 850-2PH10
TP XP patch cable 9/9	Crossover TP patch cable for direct interconnection of two industrial Ethernet network components with ITP interface, with two 9-pin sub-D connectors	1.0 m	6XV1 850-2RH10
TP cord RJ45/15	TP patch cable with 15-pin sub-D connector and RJ45 connector	0.5 m	6XV1 850-2LE50
		1.0 m	6XV1 850-2LH10
		2.0 m	6XV1 850-2LH20
		6.0 m	6XV1 850-2LH60
		10.0 m	6XV1 850-2LNN10
TP XP patch cable RJ45/15	Crossover TP patch cable with 15-pin sub-D connector and RJ45 connector.	0.5 m	6XV1 850-2SE50
		1.0 m	6XV1 850-2SH10
		2.0 m	6XV1 850-2SH20
		6.0 m	6XV1 850-2SH60
		10.0 m	6XV1 850-2SN10

**Industrial Ethernet Fast Connect twisted-pair cables**

The FastConnect Twisted-Pair cabling system is ideal for structured cabling in the production hall. FastConnect cables allow for the quick and easy on-site assembly of patch cables. The RJ45 cabling technology is the existing standard and is also available as an industrial version which allows structured cabling.

**Product range**

Industrial Ethernet Fast Connect twisted-pair cables available:

Table 4- 24 Data for user assemblies using patch cables of the Fast Connect product family

Cable designation	Application	Available lengths	Order number
SIMATIC NET IE FC RJ 45 PLUG 145	RJ45 connector for Industrial Ethernet with rugged metal housing and four integrated insulation displacement terminals for connecting Industrial Ethernet FC installation cables; 145° cable outlet.	1 piece 10 items 50 items	6GK1 901-1BB30-0AA0 6GK1 901-1BB30-0AB0 6GK1 901-1BB30-0AE0
SIMATIC NET IE FC RJ 45 PLUG 180	RJ45 connector for Industrial Ethernet with rugged metal housing and four integrated insulation displacement terminals for connecting Industrial Ethernet FC installation cables; 180° cable outlet.	1 piece 10 items 50 items	6GK1 901-1BB10-2AA0 6GK1 901-1BB10-2AB0 6GK1 901-1BB10-2AE0

**Reference**

Detailed information is available in the

- SIMATIC NET Manual: Twisted-Pair and Fiber-Optic Networks (6GK1970-1BA10-0AA0)
- On the Internet at <http://www.siemens.com/automation/service&support>.
- Catalog IK PI, SIMATIC NET (E86060-K6710-A101-B5)

**See also**

Connecting the PG to a node (Page 142)

Connecting the PG to several nodes (Page 143)

#### 4.11.3.6 Connectors and other components for Ethernet

The selection of the bus cable, bus connector and other components for Ethernet (for example, switches, etc.) depends on the intended application.

We offer a range of products covering a variety of applications for the installation of an Ethernet connection.

#### Reference

- *SIMATIC NET: Twisted-Pair and Fiber-Optic Networks (6GK1970-1BA10-0AA0)*

#### 4.11.3.7 Example of a PROFINET Subnet

##### Example: Installation of a PROFINET subnet

The graphic illustrates the combination of corporate level and process control level via industrial Ethernet. PCs in a classical office environment can be used to acquire data of the process automation system.

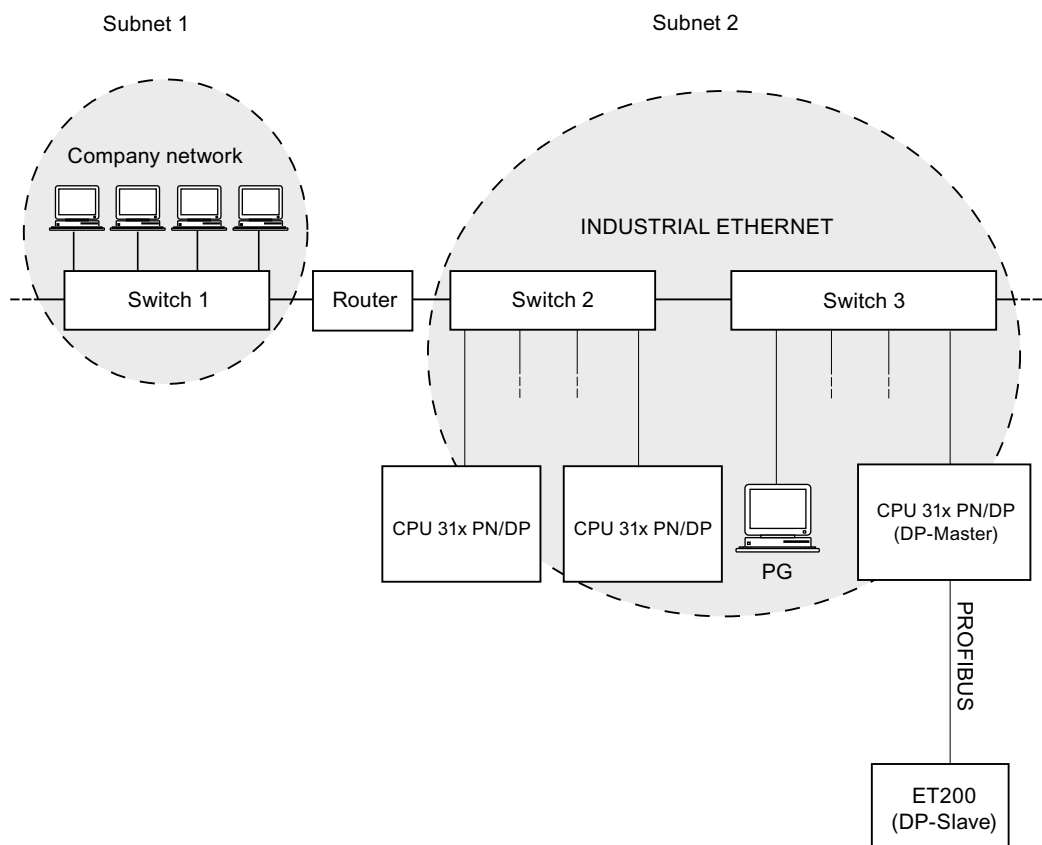

Figure 4-8 Example of a PROFINET Subnet

### Installation guidelines

PROFINET allows you to set up a high-performance and continuous communication system. You can further increase performance by using the following installation guidelines.

- Interconnect a router between the office network and the PROFINET system. Use the router to define access privileges for your PROFINET system.
- Set up your PROFINET in a star architecture where this is useful (for example: in a switch cabinet).
- Keep the number of switches low. This increases clarity of your PROFINET system architecture.
- Connect your programming device (PG) close to the communication partner (for example: connect the PG and the communication partner to the same switch).
- Modules with PROFINET interfaces may only be operated in LANs where all nodes are equipped with SELV/PELV power supplies or protection systems of equal quality.
- A data transfer device that ensures this safety must be specified for the coupling to the WAN.

### Reference

For detailed information on Industrial Ethernet networks or network components, refer to:

- the Internet URL <http://www.siemens.com/automation/service&support>.
- The STEP 7 Online Help. There you can also find further information on IP address assignment.
- The Communication with SIMATIC (EWA 4NEB 710 6075-01) manual
- The SIMATIC NET manual: Twisted-Pair and Fiber Optic Networks (6GK1970-1BA10-0AA0)

### 4.11.3.8 PROFINET IO System

#### Functions of PROFINET IO

The following graphic shows the new functions in PROFINET IO:

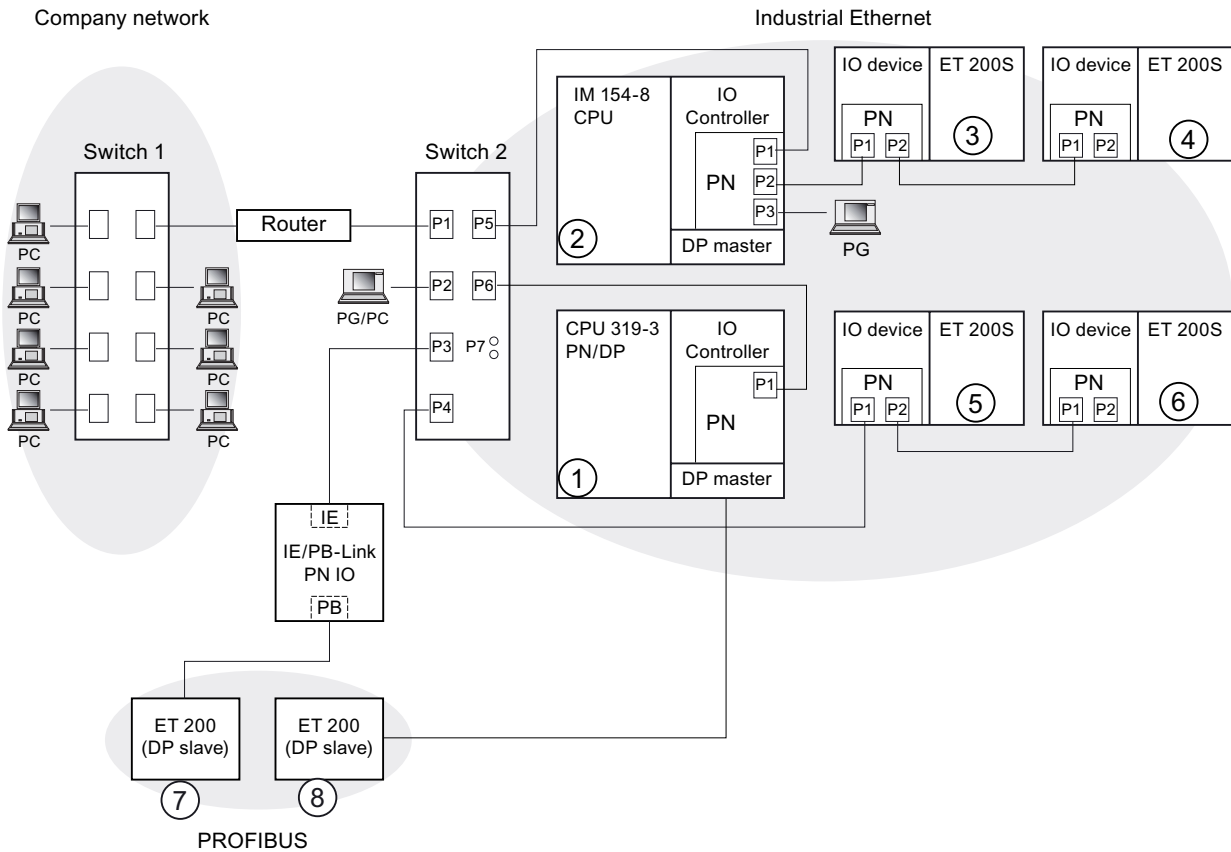

The graphic shows	Examples of connection paths
The connection of company network and field level	You can access devices at the field level from PCs in your company network Example: <ul style="list-style-type: none"> <li>PC - Switch 1 - Router - Switch 2 - CPU 319-3 PN/DP ①.</li> </ul>
Connections between the automation system and field level	You can, of course, also access other areas on the Industrial Ethernet from a PG at the field level. Example: <ul style="list-style-type: none"> <li>PG - integrated switch IM 154-8 CPU ② - Switch 2 - integrated switch IO device ET 200S ⑤ - on IO device: ET 200S ⑥.</li> </ul>

The graphic shows	Examples of connection paths
<p>The IO controller of the CPU IM 154-8 CPU ② <b>directly</b> controls devices on the Industrial Ethernet and PROFIBUS.</p>	<p>At this point, you can see the extended IO feature between the IO controller and IO device(s) on the Industrial Ethernet:</p> <ul style="list-style-type: none"> <li>• The IM 154-8 CPU ② is operated as IO controller for the IO devices ET 200S ③ and ET 200S ④</li> <li>• The IM 154-8 CPU ② is also the IO controller for ET 200 (DP slave) ⑦ by way of IE/PB Link.</li> </ul>
<p>The CPU 319-3 PN/DP ① can be operated as IO controller or DP master</p>	<p>Here you can see that a CPU can be both the IO controller for an IO device and the DP master for a DP slave:</p> <ul style="list-style-type: none"> <li>• The 319-3 PN/DP CPU ① is operated as IO controller for the IO devices ET 200S ⑤ and ET 200 S ⑥</li> <li>• The CPU 319-3 PN/DP ① is the DP master for a DP slave ⑧. The DP slave ⑧ is assigned locally to the CPU ① and is not visible on the Industrial Ethernet.</li> </ul>

**Further information**

You will find further information about PROFINET in the documents listed below:

- in the *System Description PROFINET*.
- In the *From PROFIBUS DP to PROFINET IO programming manual*. This manual also provides a clear overview of the new PROFINET blocks and system status lists.

**4.11.4 Routed network transitions**

**Example: Programming device access beyond network limits (routing)**

A CPU with several interfaces can also serve as a router for intercommunication with different subnets. With a PG you can access all modules on local and remote networks.

**Requirements:**

- Implement STEP 7 starting with Version 5.0.  
Note: For STEP 7 requirements with respect to the CPUs used, refer to the technical specifications.
- Assign the PG/PC to a network in your STEP 7 project (SIMATIC Manager, assigning a PG/PC).
- The various networks are interconnected using modules with routing functions.
- After you configured all networks in NETPRO, initiated a new compilation for all stations, and then download the configuration to all modules with routing function. This also applies to all changes made in the network.

All routers therefore know all paths to a destination station.

## Access to remote networks

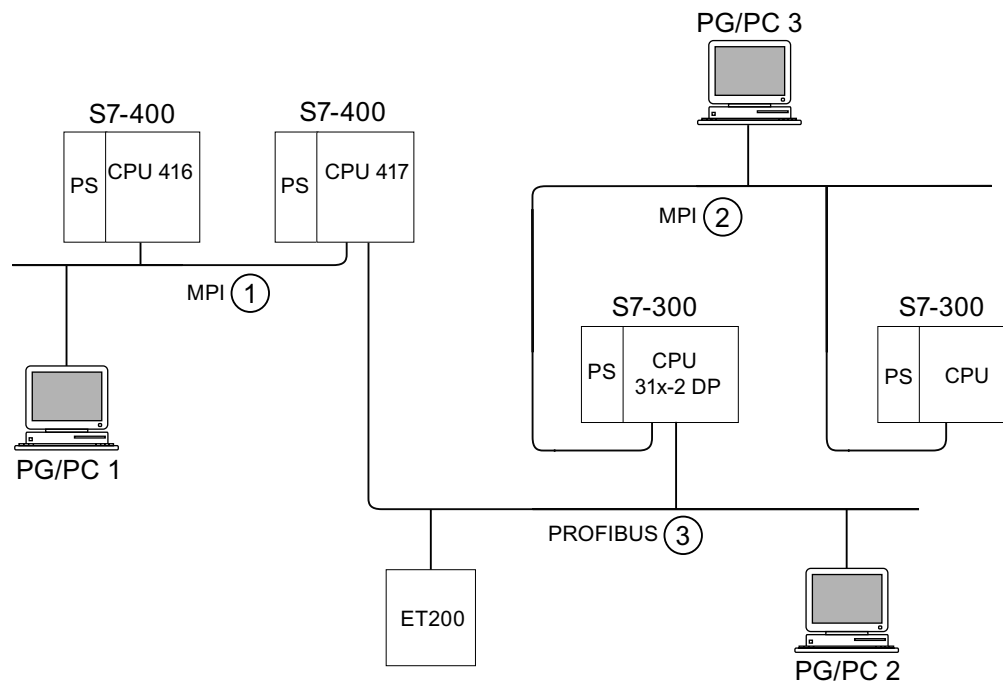

Figure 4-9 Access to remote networks

### Example 1

To access the CPU 31x-2 DP using PG/PC 1:

PG/PC 1 - MPI network ① - CPU 417 as router - PROFIBUS network ① - CPU 31x-2 DP

### Example 2

To access the the S7-300 CPU (on the right in the figure) using PG/PC 2:

PG/PC 2 - PROFIBUS network ③ - CPU 31x-2 DP as router - MPI network ③ - S7-300 CPU

### Example 3

To access the 416 CPU using PG/PC 3:

PG/PC 3 - MPI network ② - CPU 31x-2 DP as router - PROFIBUS network ② - CPU 417 as router - MPI network ② - CPU 416

---

### Note

#### Only for CPUs with DP interface:

If these CPUs are operated as I-slaves and you want to use routing functionality, set the Commissioning / Debug Mode / Routing check box in the DP Interface for DP Slave dialog box in STEP 7.

---

### Information on routing can be found ...

- *CPU Data Reference Manual* for your CPU
- In the *Communication with SIMATIC* manual.

### 4.11.5 Point-to-point (PtP)

#### Availability

CPUs with the "PtP" name suffix have at least one PtP interface.

#### Features

Using the PtP interface of your CPU, you can connect external devices with serial interface. You can operate such a system at transmission rates up to 19.2 kbps in full duplex mode (RS 422), and up to 38.4 kbps in half duplex mode (RS 485).

#### Transmission rate

- Half duplex: 38.4 kbps
- Full duplex: 19.2 kbps

#### Drivers

PtP communication drivers installed in those CPUs:

- ASCII drivers
- 3964(R) Protocol
- RK 512 (CPU 314C-2 PtP only)

#### Devices capable of PtP communication

Devices equipped with a serial port, for example, barcode readers, printers, etc.

#### Reference

*CPU 31xC: Technological functions manual*

### 4.11.6 Actuator/sensor interface (ASI)

#### Actuator/Sensor Interface (ASI)

**Implementation using communication processors (CP).**

The ASI, or Actuator/Sensor Interface, represents a subnet system on the lowest process level for automation systems. It is designed especially for networking digital sensors and actuators. The maximum data volume is 4 bits per slave station.

S7-300 CPUs require communication processor for the ASI connection.



# Installing

## 5.1 Installing a S7-300

Here we will explain the steps required for the mechanical assembly of an S7-300.

---

**Note**

Note the installation guidelines and notes on safety in this manual when mounting, commissioning and operating S7-300 systems.

---

### Open components

S7-300 modules are "Open Components" according to IEC 61131-2 and EC directive 2006/95/EC (low-voltage directive), and to UL/CSA Approval an "open type".

In order to conform with specifications on safe operation relating to mechanical strength, inflammability, stability and touch-protection, the following alternative installation modes are prescribed:

- Installation in a suitable cubicle
- Installation in a suitable cabinet
- Installation in an appropriately equipped and closed operating area

Access to these areas must only be possible with a key or tool. Only trained or authorized personnel are allowed access to these cubicles, cabinets or electrical operating rooms.

**Accessories included**

Installation accessories are included with the module package. The appendix contains a list of accessories and spare parts together with the corresponding order numbers.

Table 5- 1 Module accessories

Module	Accessories included	Explanation
CPU	1 x Slot number label	For assigning slot numbers
	Inscription labels	for the MPI address and Firmware Version (all CPUs) for labeling of integrated inputs and outputs (CPU 31xC only)
Signal module (SM) Function Module (FM)	1 Bus connector	For electrical interconnection of modules
	1 Labeling strip	For labeling module I/O
Communication module (CP)	1 Bus connector	For electrical interconnection of modules
	1 Inscription label (only CP 342-2)	For labeling the AS interface connector
Interface module (IM)	1 x Slot number label (only IM 361 and IM 365)	For assigning slot numbers on racks 1 to 3

Tip: Templates for labeling strips are available on the Internet at [http://www.siemens.com/automation/csi\\_en\\_ww/11978022](http://www.siemens.com/automation/csi_en_ww/11978022).

**Tools and material required**

To install the S7-300, you require the tools and materials listed in the table below.

Table 5- 2 Installation tools and materials

You require ...	for ...
cutting the 2 m rail to length	commonly available tool
scribing and drilling holes on the 2 m rail	commonly available tool, 6.5 mm diameter drill bit
screw-mounting the rail	wrench or screwdriver, matching the selected fixing screws diverse M6 screws (length depends on the place of installation) with nuts and spring lock washers
screw-fastening the modules on the rail	screwdriver with 3.5 mm blade width (cylindrical design)
pulling out the grounding slide contact to achieve ungrounded state	screwdriver with 3.5 mm blade width (cylindrical design)

## 5.2 Installing the mounting rail

### Mounting rail versions available

- Ready-to-use, four standard lengths (with 4 holes for fixing screws and 1 ground conductor bolt)
- One meter mounting rail  
May be shortened to any special length. Supplied without holes for fixing screws and without ground conductor bolt.

### Requirement

Prepare the 2 m mounting rail for installation.

### Preparing the 2 m mounting rail for installation

1. Cut the 2 m mounting rail to the required length.
2. Mark out:
  - four bores for the fixing screws (for dimensions, refer to "Dimensions for fixing holes")
  - one hole for the protective conductor bolt.
3. If the length of your rail exceeds 830 mm, you must stabilize it by providing additional holes for fixing it with more screws.  
  
Mark out these holes along the groove in the middle section of the rail (see the Figure below). The pitch should be approx. 500 mm.
4. Drill the marked holes, bore diameter =  $6.5^{+0.2}$ mm for M6 screws.
5. Mount an M6 bolt for fixing the ground conductor.

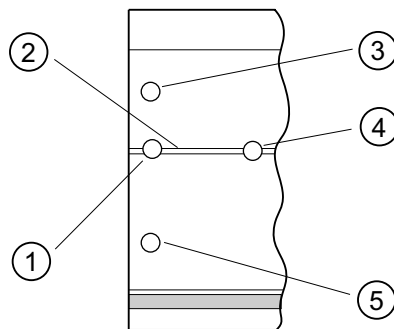

Number	Identifier
①	Hole for the ground conductor bolt
②	Groove for drilling additional holes for mounting screws
③	Hole for the mounting screw
④	Additional hole for mounting screw
⑤	Hole for the mounting screw

**Dimension of the mounting holes**

The mounting hole dimensions for the mounting rail are shown in the table below.

Table 5- 3 Mounting holes for rails

"Standard" mounting rail			2 m mounting rail		
Length of rail	Dimension a	Dimension b	-		
160 mm	10 mm	140 mm			
482.6 mm	8.3 mm	466 mm			
530 mm	15 mm	500 mm			
830 mm	15 mm	800 mm			

**Fixing screws**

You can use the following screw types for mounting the rails:

For ...	you can use ...	Explanation
outer fixing screws	Cylindrical head screw M6 to ISO 1207/ISO 1580 (DIN 84/DIN 85)	Choose a suitable screw length for your assembly. You also need size 6.4 washers to ISO 7092 (DIN 433)
	M6 hexagonal head screw to ISO 4017 (DIN 4017)	
Additional fixing screws (only 2 m mounting rail)	Cylindrical head screw M6 to ISO 1207/ISO 1580 (DIN 84/DIN 85)	

### Installing the mounting rail

1. Install the mounting rails so that sufficient space is available for installing modules and to allow heat dissipation (clearance of at least 40 mm above and below the modules. See the figure below).
2. Mark up the mounting holes on the mounting surface. Drill the holes, diameter = 6.5 +0.2 mm.
3. Screw the rail (M6 screws) onto the mounting surface.

---

#### Note

Always make sure of a low-impedance contact between the rail and a mounting surface, if the latter is a grounded metal panel or equipment mounting panel. On varnished or anodized metals, for instance, use a suitable contacting agent or contact washers.

---

The figure below shows the clearance required for the installation of an S7-300.

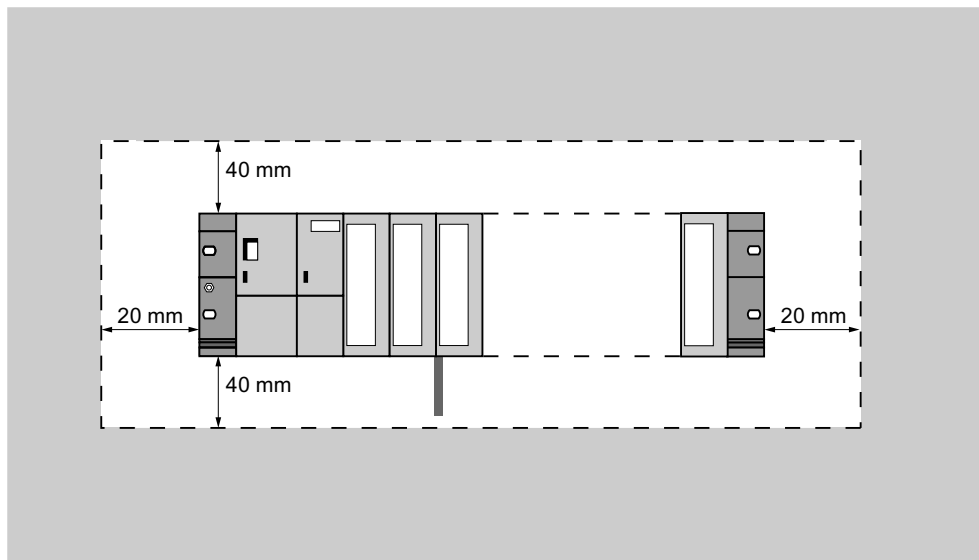

## 5.3 Installing modules on the mounting rail

### Requirements for module installation

- The configuration of the automation system is completed.
- The mounting rail is installed.

### Mounting order of the modules

Hang the modules onto the rail, starting at the left and in the following order:

1. Power supply module
2. CPU
3. SMs, FMs, CPs, IMs

---

#### Note

Please check **before** you insert any SM 331 analog input modules whether you have to reposition the measuring range submodules at the side of the module. For more information see the "Analog Modules" chapter in the *Module Data Manual*.

---

#### Note

When installing an S7-300 system with ungrounded reference potential, make the relevant settings on the CPU. You ideally do so before you mount any modules onto the rail.

---

## Installation steps

The various steps in module installation are explained below.

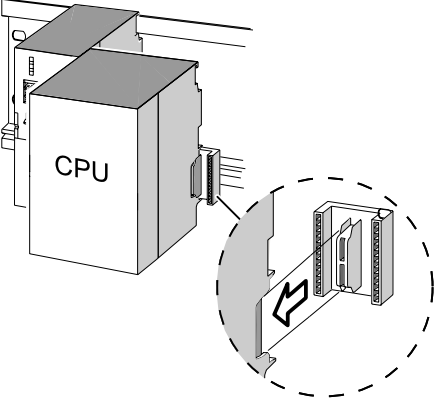
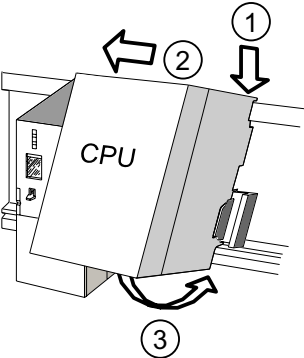
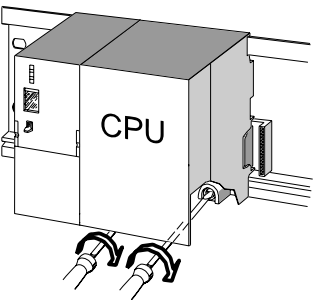
<p>1.</p>	<p>Plug the bus connectors into the CPU and SMs / FMs / CPs / IMs. Except for the CPU, each module is supplied with a bus connector.</p> <ul style="list-style-type: none"> <li>• Always start at the CPU when you plug in the bus connectors. Remove the bus connector from the "last" module of the assembly.</li> <li>• Plug the bus connectors into the other modules. The "last" module does not receive a bus connector.</li> </ul>	
<p>2.</p>	<p>Add all modules to the rail in the specified order ①, slide them up to the module on the left ②, then swing them down ③.</p>	
<p>3.</p>	<p>Screw-tighten the modules.</p>	

## See also

Installing an S7-300 with ungrounded reference potential (not CPU 31xC) (Page 39)

## 5.4 Labeling modules

### Assign slot numbers

You should assign a slot number to each one of the mounted modules, thus making it easier to assign the modules in the configuration table in STEP 7. The table below shows the slot number assignment.

Table 5- 4 Slot numbers for S7 modules

Slot number	Module	Remark
1	Power supply (PS) module	–
2	CPU	–
3	Interface module (IM)	to the right of the CPU
4	1. Signal module (SM)	to the right of the CPU or IM
5	2. Signal module (SM)	–
6	3. Signal module (SM)	–
7	4. Signal module (SM)	–
8	5. Signal module (SM)	–
9	6. Signal module (SM)	–
10	7. Signal module (SM)	–
11	8. Signal module (SM)	–



**Attach the slot numbers to the modules.**

1. Hold the corresponding slot number in front of the relevant module.
  2. Place the tongue in the opening on the module ①.
  3. Press the slot number into the module ②. The slot number breaks off from the wheel.
- The figure below illustrates this procedure. The slot number labels are included with the CPU.

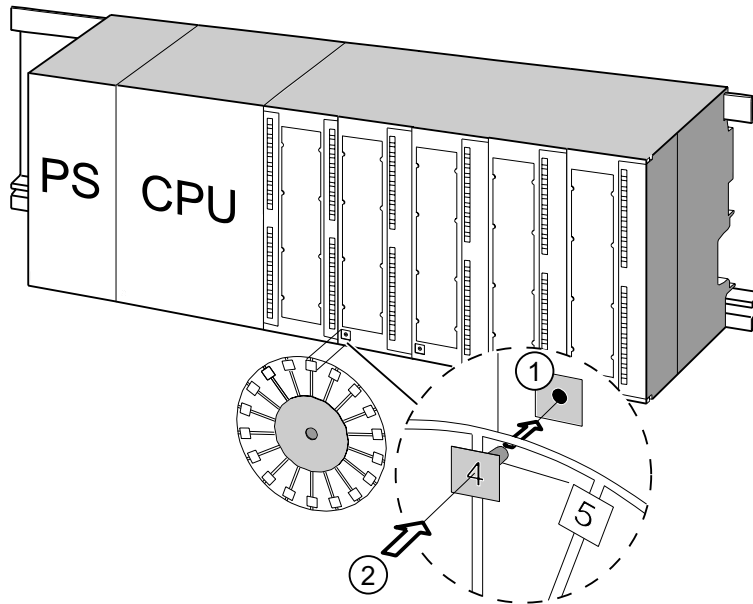



# Wiring

## 6.1 Requirements for wiring the S7-300

### This chapter

Describes the requirements for wiring the PS, CPU and front connectors.

### Accessories required

The following accessories are required for wiring the S7-300.

Table 6- 1 Wiring accessories

Accessories	Description
Front connectors	for connecting the sensors / actuators of the system to the S7-300
Labeling strips	for labeling the module I/Os
Shielding contact element, shielding terminals (matching the shielding diameter)	for connecting cable shielding

### Tools and material required

Tools and materials required for wiring the S7-300.

Table 6- 2 Tools and material for wiring

To ...	you need ...
Connect the protective conductor to the rail	Wrench (size 10) Protective conductor cable (cross-section $\geq 10 \text{ mm}^2$ ) with M6 cable lug M6 nut, washer, spring lock washer
Adjust the power supply module to mains voltage	Screwdriver with a blade width of 4.5 mm
Wire the power supply module and the CPU	Screwdriver with a 3.5-mm blade, side-cutters, stripping tool Flexible cable, for example, sheathed flexible cable $3 \times 1.5 \text{ mm}^2$ Wire end ferrules to DIN 46228
Wire the front connector	Screwdriver with a 3.5-mm blade, side-cutters, stripping tool Flexible cables, $0.25 \text{ mm}^2$ to $0.75/1.5 \text{ mm}^2$ Shielded cables as required Wire end ferrules to DIN 46228

### Wiring conditions for PS and CPU

Table 6- 3 Wiring conditions for PS and CPU

Connectable cables	to PS and CPU
Solid conductors	No
Flexible conductors <ul style="list-style-type: none"> <li>without wire end ferrule</li> <li>With wire end ferrule</li> </ul>	0.25 mm <sup>2</sup> to 2.5 mm <sup>2</sup> 0.25 mm <sup>2</sup> to 1.5 mm <sup>2</sup>
Number of conductors per terminal	1 or 2, up to 1.5 mm <sup>2</sup> (total) in a common wire end ferrule
Diameter of the conductor insulation	max. 3.8 mm
Stripped length	11 mm
Wire end ferrules to DIN 46228 <ul style="list-style-type: none"> <li>without insulating collar</li> <li>with insulating collar</li> </ul>	Design A, 10 mm to 12 mm length Design E, up to 12 mm length

### Wiring conditions for front connectors

Table 6- 4 Wiring conditions for front connectors

Connectable cables	Front connectors	
	20-pole	40-pole
Solid conductors	No	No
Flexible conductors <ul style="list-style-type: none"> <li>without wire end ferrule</li> <li>with wire end ferrule</li> </ul>	0.25 mm <sup>2</sup> to 1.5 mm <sup>2</sup> 0.25 mm <sup>2</sup> to 1.5 mm <sup>2</sup>	0.25 mm <sup>2</sup> to 0.75 mm <sup>2</sup> 0.25 mm <sup>2</sup> to 0.75 mm <sup>2</sup> <ul style="list-style-type: none"> <li>Mains feed 1.5 mm<sup>2</sup></li> </ul>
Number of conductors per terminal	1 or 2, up to 1.5 mm <sup>2</sup> (total) in a common wire end ferrule	1 or 2, up to 0.75 mm <sup>2</sup> (total) in a common wire end ferrule
Diameter of the conductor insulation	max. 3.1 mm	<ul style="list-style-type: none"> <li>max. 2.0 mm for 40-pole cables</li> <li>max. 3.1 mm for 20-pole cables</li> </ul>
Stripped length	6 mm	6 mm
Wire end ferrules to DIN 46228 <ul style="list-style-type: none"> <li>without insulating collar</li> <li>with insulating collar</li> </ul>	Design A, 5 mm to 7 mm length Design E, up to 6 mm length	Design A, 5 mm to 7 mm length Design E, up to 6 mm length

## 6.2 Bonding the Protective Conductor to the Mounting Rail

### Requirement

The mounting rail is fixed onto the mounting surface.

### Connecting the protective conductor

Connect the mounting rail to the protective conductor.

The mounting rail is provided with a M6 protective conductor screw for this purpose.

Minimum cross-section of the protective conductor: 10 mm<sup>2</sup>

The figure below shows how the protective conductor has to be bonded to the rail.

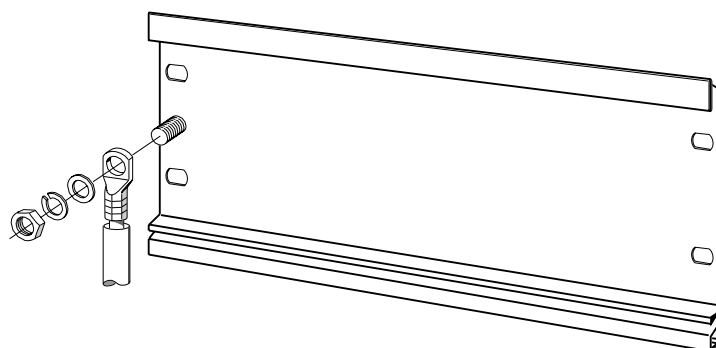

---

### Note

Always make sure of a low-impedance contact between the protective conductor and the rail. You can achieve this by using a low-impedance cable, keeping it as short as possible and contacting it to a large surface.

For example, an S7-300 mounted on a hinged frame must be connected to ground using a flexible grounding strap.

---

## 6.3 Adjusting the Power Supply Module to Local Mains Voltage

### Introduction

You can operate the S7-300 power supply module on 120 VAC or 230 VAC. The default setting for the PS 307 is 230 VAC.

### Setting the mains voltage selector switch

Verify that the setting of the voltage selector switch matches your local mains voltage.

To set the selector switch:

1. Remove the protective cap with a screwdriver.
2. Set the selector switch to match the local line voltage.
3. Reinsert the protective cap.

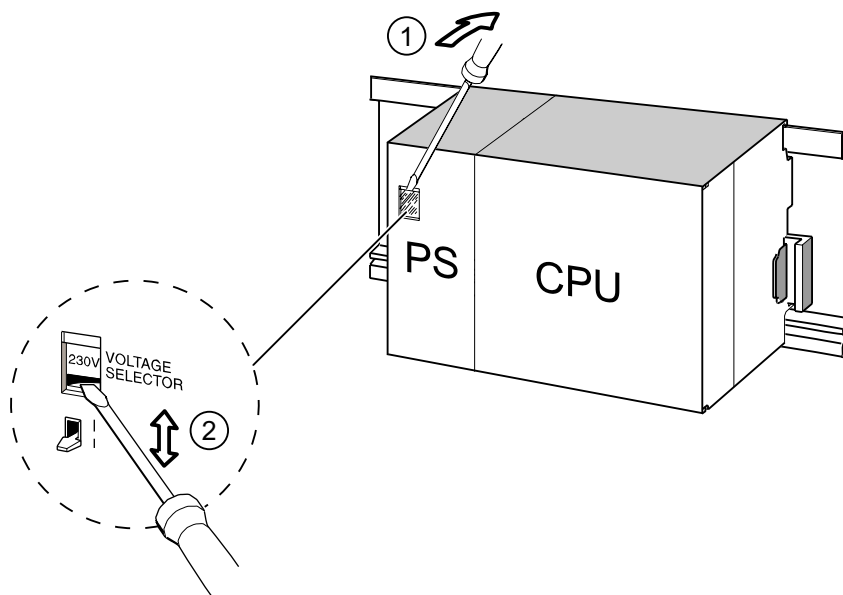

Number	Identifier
①	Remove the protective cap with a screwdriver
②	Set selector switch to mains voltage

## 6.4 Wiring the Power Supply Module and the CPU

### Requirement

All modules are mounted onto the rail.

### Wiring the PS and CPU

#### Note

The PS 307 power supply module is equipped with two additional 24 VDC terminals L+ and M for the supply to I/O modules.

#### Note

The power supply connector of your CPU is a plug-in device and can be removed.

#### WARNING

There is a risk of contact to live wires if the power supply module, or any additional load power supply units, are connected to the mains.

You should therefore isolate the S7-300 from power before you start wiring it. Always use crimp ferrules with insulating collars for the conductors. Close all front panels of the modules when you completed the wiring. This is conditional before you reconnect the S7-300 to power.

1. Open the PS 307 power supply module and CPU front panels.
2. Open the strain relief on the PS 307.
3. Strip the power cable to a length of 11 mm and connect it to L1, N and to the protective earth (PE) terminal of the PS 307.
4. Screw-tighten the strain relief again.
5. Next, wire the PS and CPU

The power supply connector of the CPUs is a removable plug-in device.

Strip the connecting cables for the CPU power supply to a length of 11 mm. Wire the lower terminal M on the PS 307 to the terminal M of the CPU and the lower terminal L+ on the PS 307 to terminal L+ of the CPU.

#### WARNING

Reversing the polarity of the M and L+ terminals trips the internal fuse on your CPU. Always interconnect the M and L+ terminals of the power supply module and of the CPU.

6. Close the front panels.

The figure below illustrates the procedures described earlier.

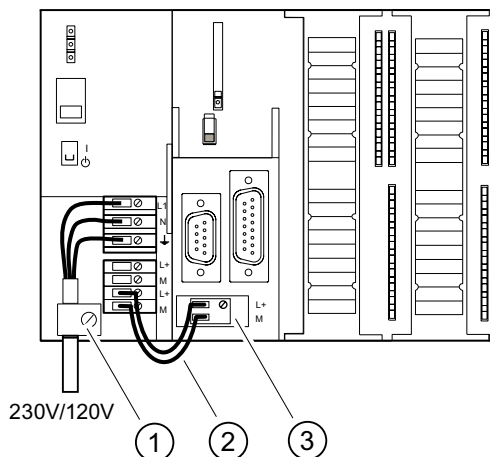

- | Number | Identifier                               |
|--------|--|
| ①      | Strain relief of the power supply cable  |
| ②      | Connection cables between the PS and CPU |
| ③      | Removable power supply connector         |

---

**Note**

The PS 307 power supply module is equipped with two additional 24 VDC terminals L+ and M for the supply to I/O modules.

---



## 6.5 Wiring front connectors

### Introduction

The sensors and actuators of your system are connected to the S7-300 AS by means of front connectors. Wire the sensors and actuators to the relevant front connector and then plug it into the module.

### Front connector versions

Front connectors come in 20-pin and 40-pin versions with screw contacts or spring terminals. You require 40-pin front connectors for the CPUs 31xC and 32-channel SMs.

Use the following front connectors as required for the module:

Table 6- 5 Assignment of front connectors to modules

Module	Front connector with screw terminals, order no.:	Front connector with spring terminals, order no.:
Signal modules (not 32-channel), Function modules, Communication module CP 342-2	6ES7 392-1AJ00-0AA0	6ES7 392-1BJ00-0AA0
Signal modules (32-channel) and CPU 31xC	6ES7 392-1AM00-0AA0	6ES7 392-1BM01-0AA0

### Connecting on spring terminals

It is quite easy to wire a front connector with spring terminals: Simply insert the screwdriver vertically into the opening with the red opening mechanism, insert the wire into the terminal and remove the screwdriver.

 <b>WARNING</b>
You might damage the spring clamp mechanism of the front connector if you turn the screwdriver sideways or use the wrong size of screwdriver. Always slide a matching screwdriver vertically into the desired opening until it reaches the mechanical stop. This ensures that the spring terminal is fully open.

### Tip

There is a separate opening for test probes up to 2 mm in diameter to the left of the opening for the screwdriver.

### Requirement

The modules (SM, FM, CP 342-2) are mounted on the rail.

### Preparing the front connectors and cables

<b>⚠ WARNING</b>
There is a risk of contact to live wires if the power supply module, or any additional load power supply units, are connected to the mains.
You should therefore isolate the S7-300 from power before you start wiring it. Close all front panels of the modules when you completed the wiring. This is conditional before you reconnect the S7-300 to power.

1. Switch off the power supply.
2. Open the front door.
3. Place the front connector into wiring position.

Push the front connector into the signal module until it latches. In this position, the front connector still protrudes from the module.

Advantage of this wiring position: Comfortable wiring.

The front connector pins do not contact the module in this wiring position.

4. Strip the conductors to a length of 6 mm.
5. Crimp the wire end ferrules, for example, to terminate two conductors at one terminal.

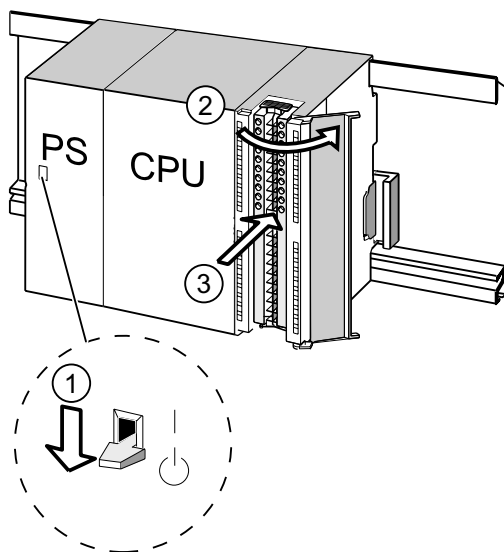

- | Number | Identifier                                |
|--------|---|
| ①      | The switched off power supply module (PS) |
| ②      | The opened module                         |
| ③      | The front connector in wiring position    |

### Wiring front connectors

Table 6- 6 Wiring front connectors

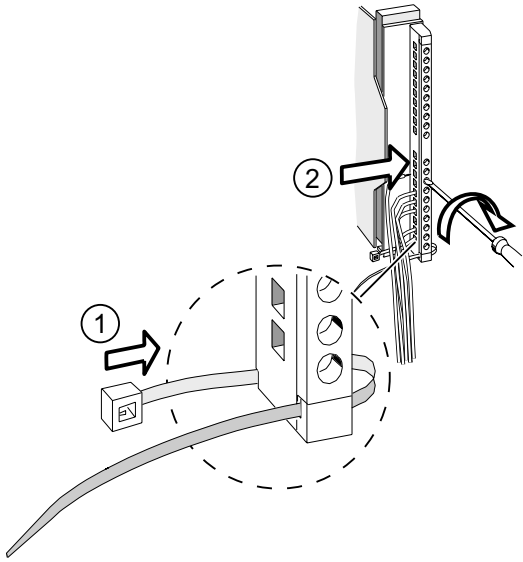
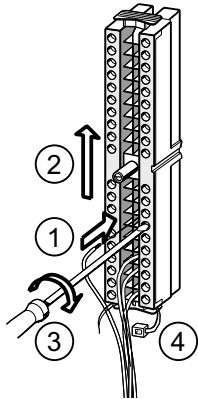
Step	20-pin front connector	40-pin front connector
1.	Place the included cable strain relief into the front connector.	–
2.	Cable exit at the bottom of the module? <b>If yes:</b> Starting at terminal 20, work your way down to terminal 1. <b>If not:</b> Start wiring at terminal 1, and work your way up to terminal 20.	Start wiring at terminal 40 or 20, and work in alternating passes from terminals 39, 19, 38, 18 etc. until you have reached terminals 21 and 1.  Start wiring at terminal 1 or 21, and work in alternating passes from terminals 2, 22, 3, 23 etc. until you have reached terminals 20 and 40.
3.	<b>Front connectors with screw terminals:</b> Always screw-tighten the unused terminals.	
4.	–	Place the strain relief around the cable harness and the front connector.
5.	Tighten the strain relief for the cable harness. Push in the strain relief to the left to increase cable space.	
–		
	The work step numbers are shown in the figure above	
	① Insert the strain relief. ② Wire the terminals.	① to ③ Wire the terminals. ④ Tighten the strain relief clamp.

### Reference

For information on wiring the integrated I/O of 31xC CPUs, refer to the *CPU 31xC and CPU 31x, Technical Data* manual.

## 6.6 Plugging the front connectors into modules

### Requirement

The front connectors are completely wired.

### Inserting the front connector

Table 6- 7 Inserting the front connector

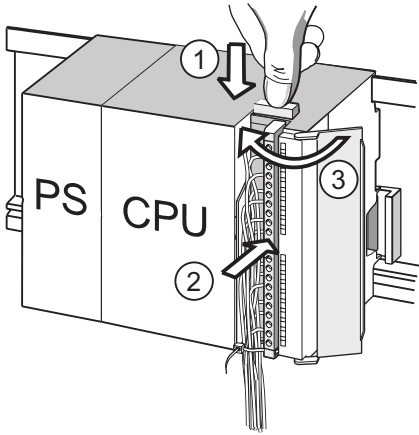
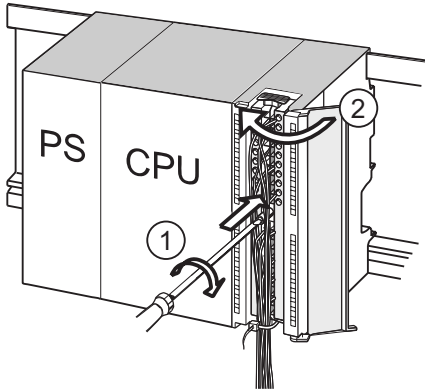
Step	20pin front connector	40pin front connector
1.	<p>Push in the unlocking mechanism on top of the module.</p> <p>Keeping the locking mechanism pressed, insert the front connector into the module.</p> <p>Provided the front connector is seated correctly in the module, the unlocking mechanism automatically returns to the initial position when you release it.</p> <p><b>Note</b></p> <p>When you insert the front connector into the module, an encoding mechanism engages in the front connector, thus ensuring that the connector can only be inserted into modules of the same type.</p>	<p>Tighten the mounting screw in the center of the connector.</p> <p>This pulls the front connector completely into contact with the module.</p>
2.	Close the front panel.	Close the front panel.
		
	The work step numbers are shown in the figure above	
	<p>① Keep the release mechanism pressed</p> <p>② Insert the front connector</p> <p>③ Only then close the front panel</p>	<p>① Tighten the mounting screw,</p> <p>③ Only then close the front panel</p>

**Order numbers for Fast Connect Connectors**

- 20-pin connector: 6ES7392-1CJ00-0AA0
- 40-pin connector: 6ES7392-1CM00-0AA0



### Wiring I/O modules and compact CPUs with Fast Connect

- I/O modules and compact CPUs can be wired with Fast Connect. The individual wires are connected by means of the front connector using Fast Connect technology, which requires no stripping.
- Fast Connect is a connection method that requires no conductor preparation (i.e., the conductor insulation does not have to be stripped).
- Each terminal with Fast Connect has a test opening (e.g. for measuring the voltage). The test opening is suitable for test probes with a maximum diameter of 1.5 mm.
- Wire end ferrules are not permitted.

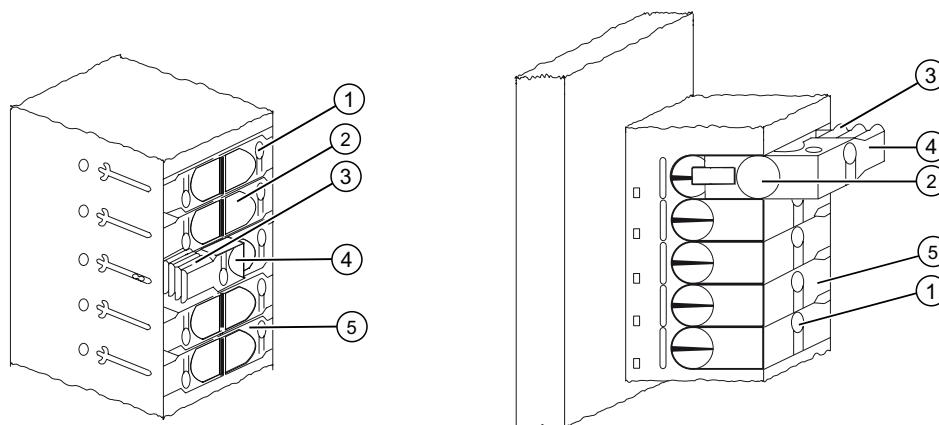

Figure 6-1 Schematic representation of Fast Connect connectors

Numeral	Designation
①	Opening for testing: max. Ø 1.5 mm
②	Opening for a conductor: 0.25 mm <sup>2</sup> to 1.5 mm <sup>2</sup>
③	Toothing for opening the terminal
④	Guide clip opened (the wire can be inserted)
⑤	Guide clip closed (the wire is connected)

### Wiring rules for front connector with Fast Connect

	20-pin front connector	40-pin front connector
<b>Solid wires</b>	No	No
<b>Connectable wire cross-section of flexible wires</b>		
• Without wire end ferrule	0.25 mm <sup>2</sup> to 1.5 mm <sup>2</sup>	0.25 mm <sup>2</sup> to 1.5 mm <sup>2</sup>
• With wire end ferrule	---	---
<b>Number of wires per terminal</b>	1	1
<b>Number of terminating cycles for the same conductor cross-section</b>	25 <sup>1</sup>	25 <sup>1</sup>
<b>Maximum external diameter of the wire insulation</b>	Ø 3.0 mm	Ø 3.0 mm
<sup>1</sup> For 1.5 mm <sup>2</sup> only 10 terminating cycles are possible. If different conductor cross-sections are used in a connecting terminal as a result of rewiring, it can be wired a maximum of 10 times.		

### Required tools

Screwdriver, 3.0 mm or 3.5 mm.

### Connectable wires

- Flexible conductors with PVC insulation and a conductor cross-section of: 0.25 mm<sup>2</sup> to 1.5 mm<sup>2</sup>

A list of the tested conductors can be found at: [http://www .weidmueller.de](http://www.weidmueller.de)

### UL-compliant cables and connections

Wiring range for insulating piercing connection 22 -16 AWG solid/stranded PVC insulated conductors, UL style no. 1015 only.

### Procedure for wiring with Fast Connect

1. Insert the unstripped wire into the round opening until it stops (**the insulation and conductor must form a flat surface**) and secure the conductor in this position.
  - For 20-pin connector: at a 90° angle
  - For 40-pin connector: at a 45° angle
2. Insert the screwdriver into the indentation on the topside of the guide clip.
3. Press the screw driver downwards until the guide clip is engaged in the end position. The wire is connected.

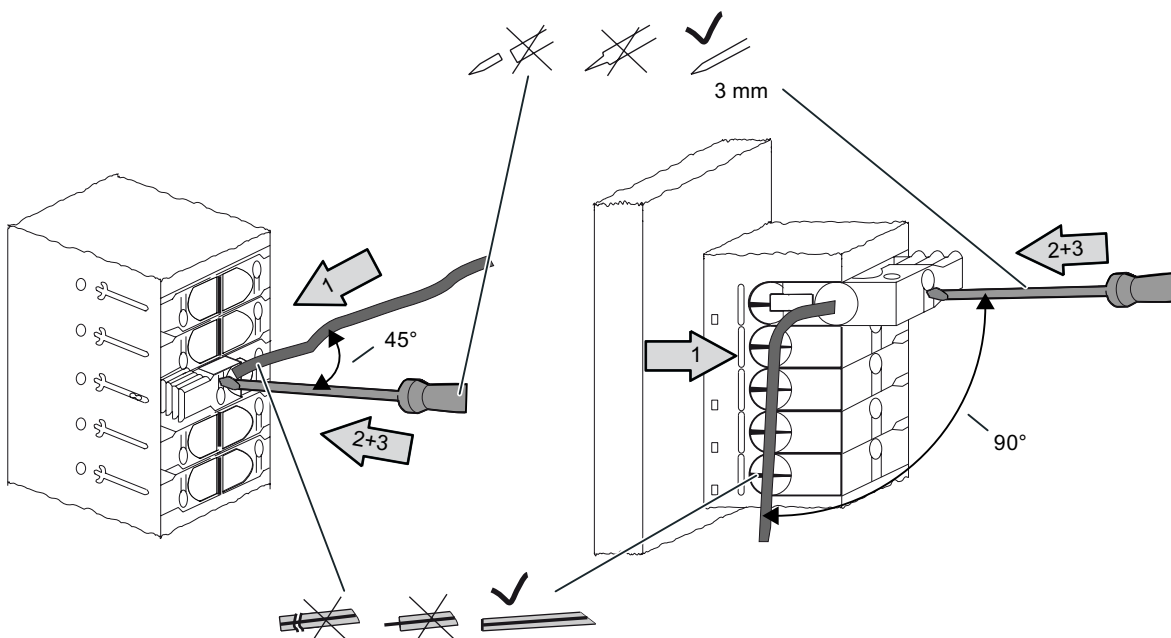

### Note

If you would like to reuse a conductor after it was already connected once then it must be trimmed beforehand.

**Procedure for disconnecting the wiring with Fast Connect**

1. Insert the screwdriver into the opening next to the guide clip until it stops.
2. Using the screwdriver, apply upward leverage to the guide clip by means of the appropriate toothing.  
Repeat this action until the guide clip is engaged in the top position.
3. The wiring is disconnected. Remove the wire.

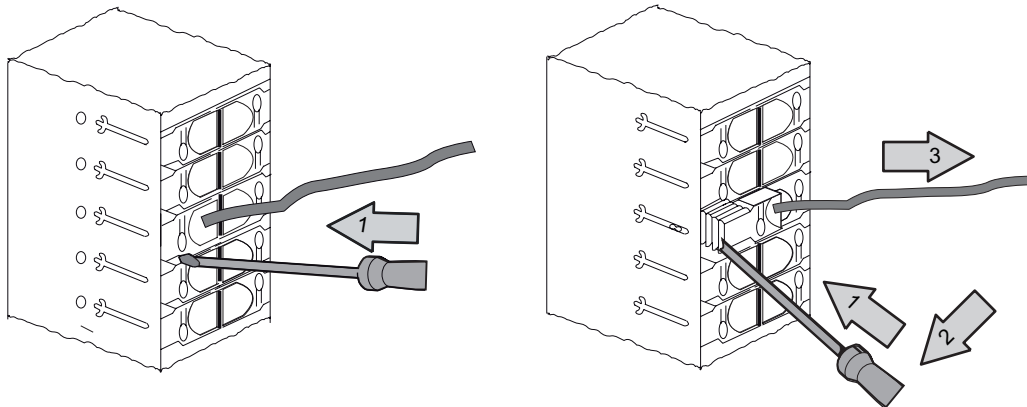

Figure 6-2 Disconnecting the wiring of a 40-pin Fast Connect connector

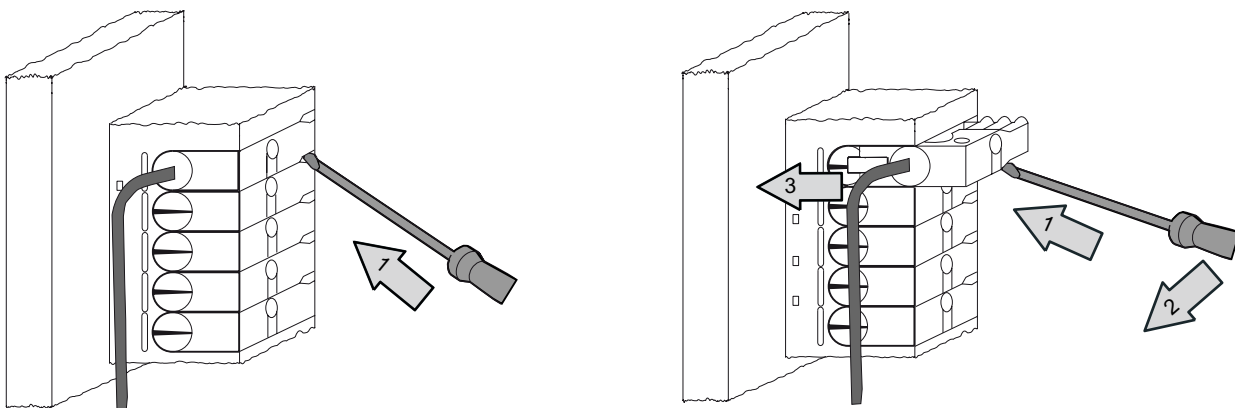

Figure 6-3 Disconnecting the wiring of a 20-pin Fast Connect connector



## 6.7 Labeling the module I/Os

### Introduction

The labeling strips are used to document the assignment of module I/Os to the sensors / actuators of your system.

You have to use the following labeling strips, depending on the module:

Table 6- 8 Assignment of labeling strips to modules

Module	Labeling strip Order no.:
SMs (not 32-channel), Function modules, Communication module CP 342-2	6ES7 392-2XX00-0AA0
SMs (32-channel)	6ES7 392-2XX10-0AA0

### Filling out and inserting labeling strips

1. Label the strips with the addresses of the sensors / actuators.
2. Slide the labeled strips into the front panel.

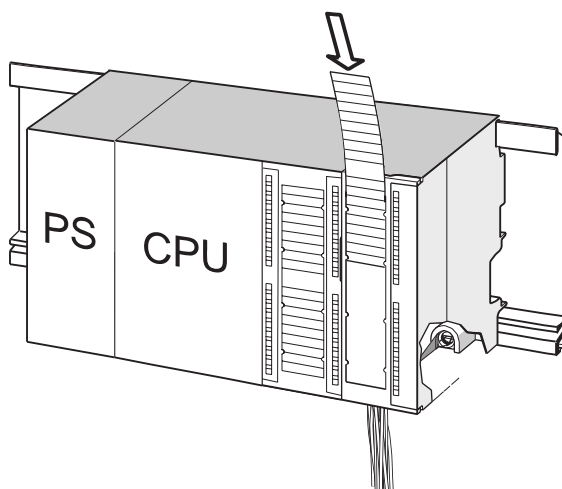

### Tip

Templates for labeling strips are available on the Internet at [http://www.siemens.com/automation/csi\\_en\\_WW](http://www.siemens.com/automation/csi_en_WW), under entry ID 11978022.

## 6.8 Terminating shielded cables on the shielding contact element

### Application

The shield connecting element allows easy grounding of all shielded cables of S7 modules, due to its direct contact to the mounting rail.

### Design of the shielding contact element

The shielding contact element consists of:

- a bracket with two screw bolts for rail mounting (order no.: 6ES5 390-5AA00-0AA0) and
- the shielding terminals.

You must use the following shielding terminals, based on the shielding diameter of your cables:

Table 6- 9 Shielding diameter assignment to shielding terminals

Cable with shielding diameter	Shielding terminal order no.:
2 cables, each with shielding diameter of 2 mm to 6 mm	6ES7 390-5AB00-0AA0
1 cable, shielding diameter 3 mm to 8 mm	6ES7 390-5BA00-0AA0
1 cable, shielding diameter 4 mm to 13 mm	6ES7 390-5CA00-0AA0

The shielding contact element width is 80 mm and provides two rows, each with 4 shielding terminals.

### Installing the shield connecting element underneath two signal modules

1. Push the two screw bolts of the bracket into the guide on the underside of the mounting rail.
2. Place the bracket underneath the modules whose shielded cables are to be terminated.
3. Screw-tighten the bracket onto the rail.
4. The shielding terminal is equipped with a slotted web underneath. Place the shielding terminal at this position onto the edge of the bracket (see figure below). Push the shielding terminal down and pivot it into the desired position.

You can install up to 4 shielding terminals on each of the two rows of the shielding contact element.

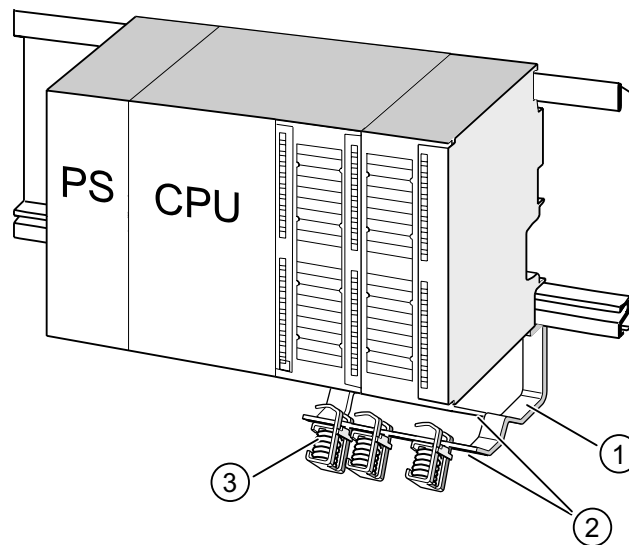

Number	Identifier
①	Bracket of shielding contact element
②	Edge of the bracket where the shielding terminal(s) has to be placed.
③	Shielding terminals

### Terminating 2-wire cables on shielding contact elements

Only one or two shielded cables may be terminated per shielding terminal (see the figure below). The cable is clamped down at the stripped cable shielding.

1. Strip the cable shielding to a length of at least 20 mm.
2. Clamp in the stripped cable shielding underneath the shielding terminal.

Push the shielding terminal towards the module ① and feed the cable through the clamp opening ②.

If you need more than four shielding terminals, start wiring at the rear row of the shielding contact element.

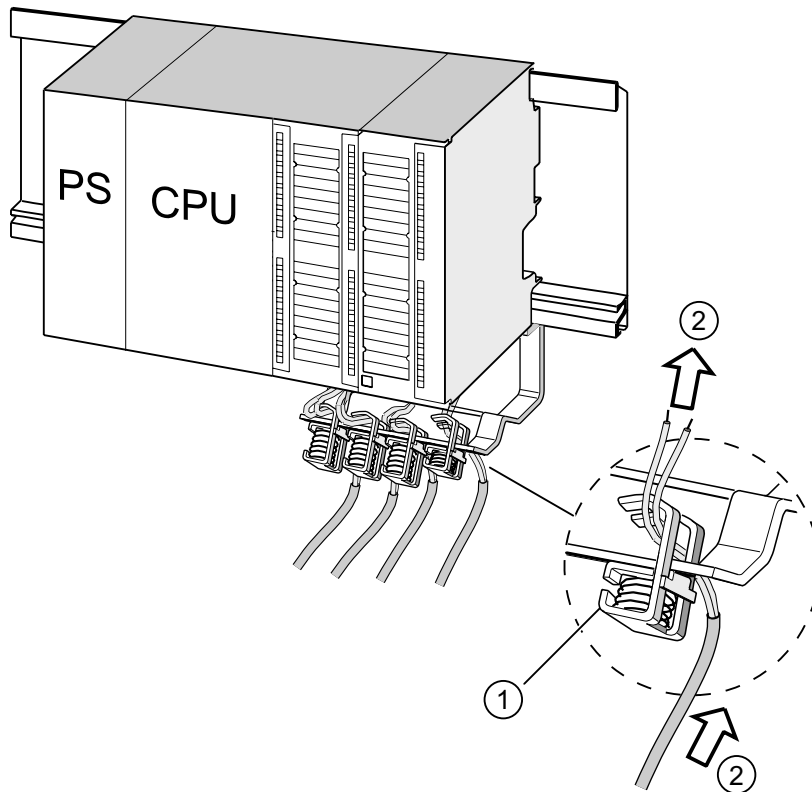

Number	Identifier
①	Magnified view of the shielding terminal
②	Wiring of the shielding terminal

#### Tip

Provide a sufficient cable length between the shielding terminal and the front connector. This allows you to disconnect the front connector for repairs, without having to disconnect the shielding terminal also, for example.

#### See also

Cable shielding (Page 252)

## 6.9 Wiring the MPI / PROFIBUS connectors

### 6.9.1 Connecting the bus connector

#### Introduction

You need to network all the nodes you integrate into a subnet of your system. Information on how to wire the bus connector can be found in the article below.

#### Wiring a bus connector with screw terminals

1. Strip the bus cable.

Details on stripped lengths are found in the product information supplied with the bus connector.

2. Open the bus connector housing.
3. Insert the green and the red wire into the screw-terminal block.

Always connect the same wires to the same terminal (green wire to terminal A, red wire to terminal B, for example).

4. Press the cable sheath into the clamp. Make sure that the shielding directly contacts the shielding contact surfaces.
5. Screw-tighten the wire terminals.
6. Close the bus connector housing.

#### Wiring a Fast Connect bus connector

1. Strip the bus cable.

Details on stripped lengths are found in the product information supplied with the bus connector.

2. Open the strain relief of the bus connector.
3. Insert the green and red wire into the open contacting covers.

Always connect the same wires to the same terminal (green wire to terminal A, red wire to terminal B, for example).

4. Close the contacting cover.  
This presses the conductors into the insulation displacement terminals.
5. Screw-tighten the strain relief clamp. Make sure that the shielding directly contacts the shielding contact surfaces.

---

**Note**

Use a bus connector with 90° cable exit.

---

#### See also

Network components of MPI/DP and cable lengths (Page 59)

### 6.9.2 Setting the terminating resistor on the bus connector

#### Inserting a bus connector in a module

1. Connect the wired bus connector to the module.
2. Screw the bus connector tightly onto the module.
3. If the bus connector is at the start or end of a segment, you have to switch on the terminator resistance (Switch position "ON"; see following figure).

---

**Note**

6ES7 972-0BA30-0XA0 bus connectors are not equipped with a terminating resistor. You cannot insert this type of bus connector at the beginning or end of a segment.

---

Please make sure during startup and normal operation that power is always supplied to nodes where the terminating resistor is active.

The figure below shows the switch settings of a bus connector:

Terminating resistor activated

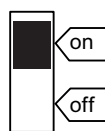

Terminating resistor not activated



#### Removing the fiber-optic cable

You can unplug a bus connector with a looped-through bus cable at any time from the PROFIBUS DP interface without interrupting data exchange on the bus.

#### Possible data traffic errors

 <b>WARNING</b>
Data traffic error might occur on the bus! A bus segment must always be terminated at both ends with the terminating resistor. For example, this is not the case when the last slave with the bus connector is deactivated. Because the bus connector takes its voltage from the station, this terminating resistor is ineffective. Please make sure that power is always supplied to stations on which the terminating resistor is active.

# Addressing

## 7.1 Slot-specific addressing of modules

### Introduction

In slot-specific addressing (default addressing if configuration data was not loaded to the CPU yet), each slot number is assigned a module start address. This is a digital or analog address, based on the type of module.

This section shows you which module start address is assigned to which slot number. You need this information to determine the start addresses of the installed modules.

### Maximum assembly and the corresponding module start addresses

The figure below shows you an S7-300 assembly on four racks, and the optional slots with their modules. Start addresses

The input and output addresses for I/O modules begin at the same module start address.

---

#### Note

On a CPU 31xC system you cannot insert any modules into slot 11 of rack 3. The address area is reserved for the integrated I/O.

---

7.1 Slot-specific addressing of modules

The figure below shows the slots of an S7-300 and the corresponding module start addresses:

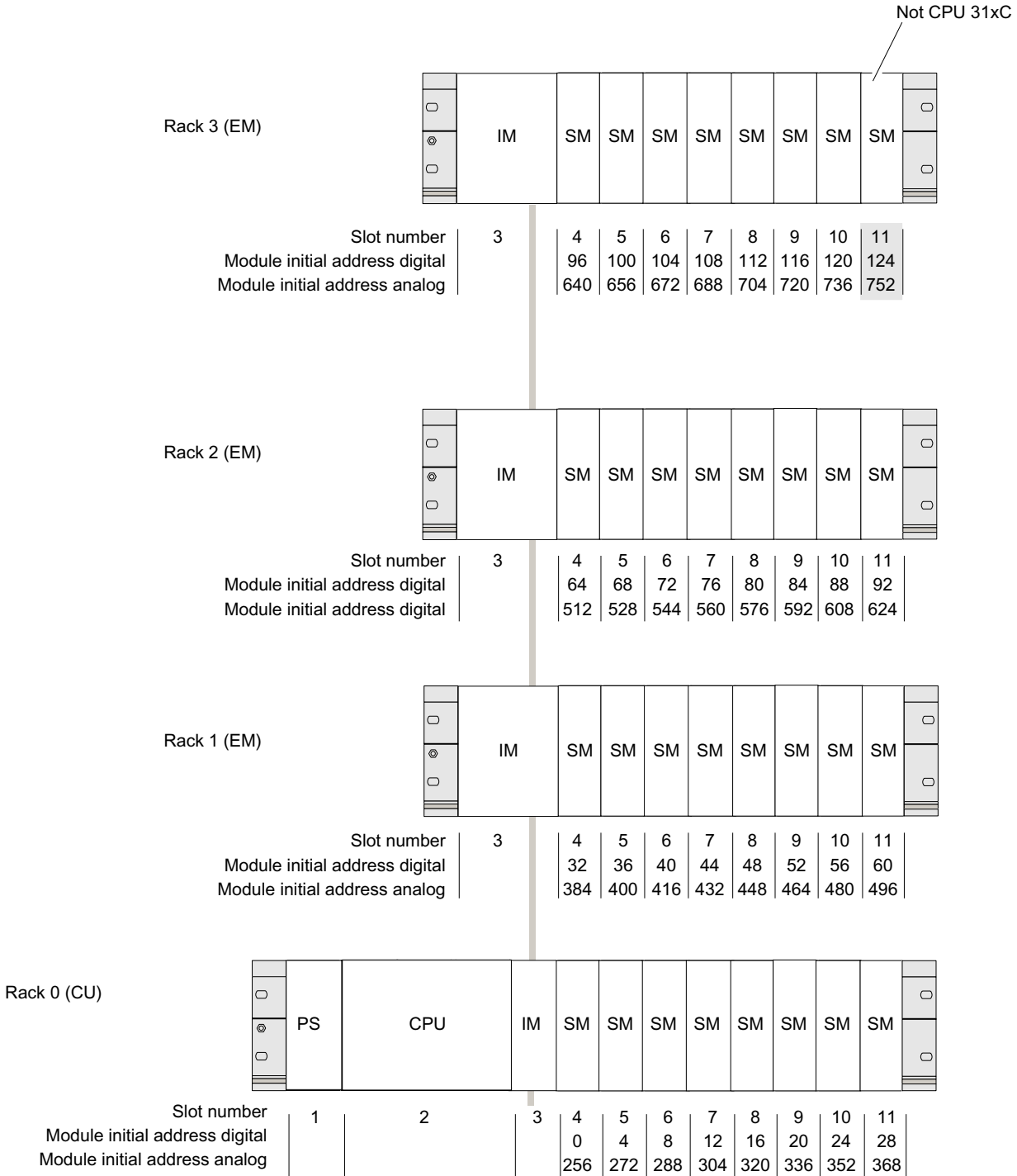



## 7.2 User-specific addressing of modules

### 7.2.1 User-specific addressing of modules

#### User-specific addressing

User-specific addressing means that you can assign an address of your choice to any module (SM/FM/CP). The addresses are assigned in STEP 7. There you specify the module start address that forms the basis for all other addresses of the module.

#### Advantages in user-specific addressing:

- Optimization of available address space as there are no "address gaps" between the modules.
- In your standard software configuration, you can define addresses which are independent of the relevant S7300 configuration.

---

#### Note

You always configure the hardware in HW Config of STEP 7 when using PROFIBUS DP or PROFINET IO field devices. User-specific addressing is automatically set in this case. There is no fixed slot addressing for such a configuration.

---

### 7.2.2 Addressing digital modules

This section describes how to assign addresses to digital modules. You need this information in order to be able to address the channels of the digital module in the user program.

#### Addresses of digital modules

The address of an input or output of a digital module consists of a byte address plus a bit address.

Example: I 1.2

The example consists of:

- input I,
- byte address 1 and
- bit address 2

The byte address is based on the module start address.

The bit address is the number printed on the module.

When the first digital module is located in slot 4, its default start address is 0. The start address of each further digital module increments by the count of 4.

The figure below shows you how the scheme by which the addresses of the various channels of a digital module are derived.

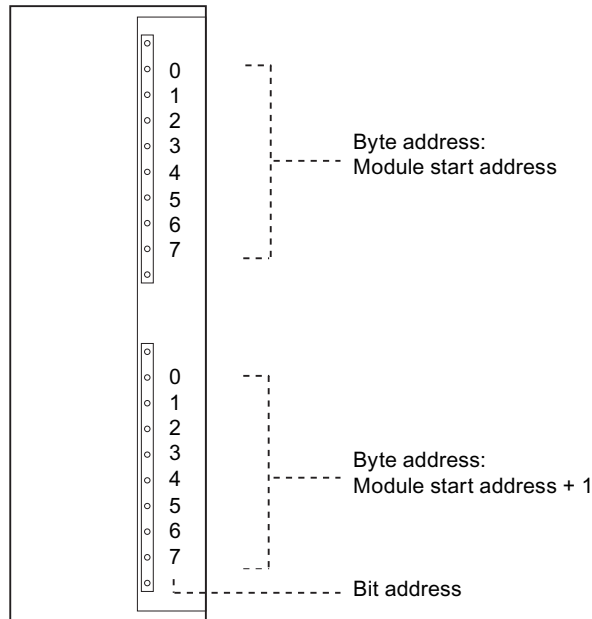

**An example of digital modules**

The example in the figure below shows which default addresses are derived when a digital module is located in slot 4 (that is, when the module start address is 0). Slot number 3 is not assigned, because the example does not contain an interface module.

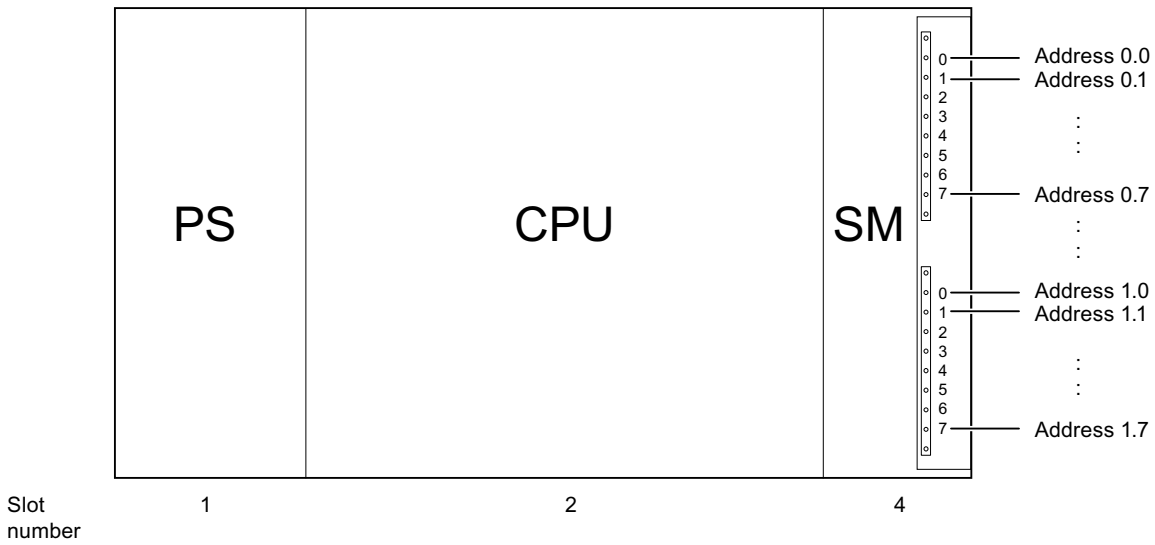

### 7.2.3 Addressing analog modules

This section describes how to address analog modules. You need this information in order to be able to address the channels of the analog modules in your user program.

#### Addresses of analog modules

The analog input or output channel is always assigned a word address. The channel address is based on the module start address. When the first analog is located in slot 4, its default start address is 256. The start address of each further analog module increments by the count of 16.

An analog I/O module has the same start addresses for its input and output channels.

#### An example of analog modules

The example in the figure below shows you which default channel addresses are derived for an analog module located at slot 4. As you can see, the input and output channels of an analog I/O module are addressed starting at the same address, namely the module start address.

Slot number 3 is not assigned, because the example does not contain an interface module.

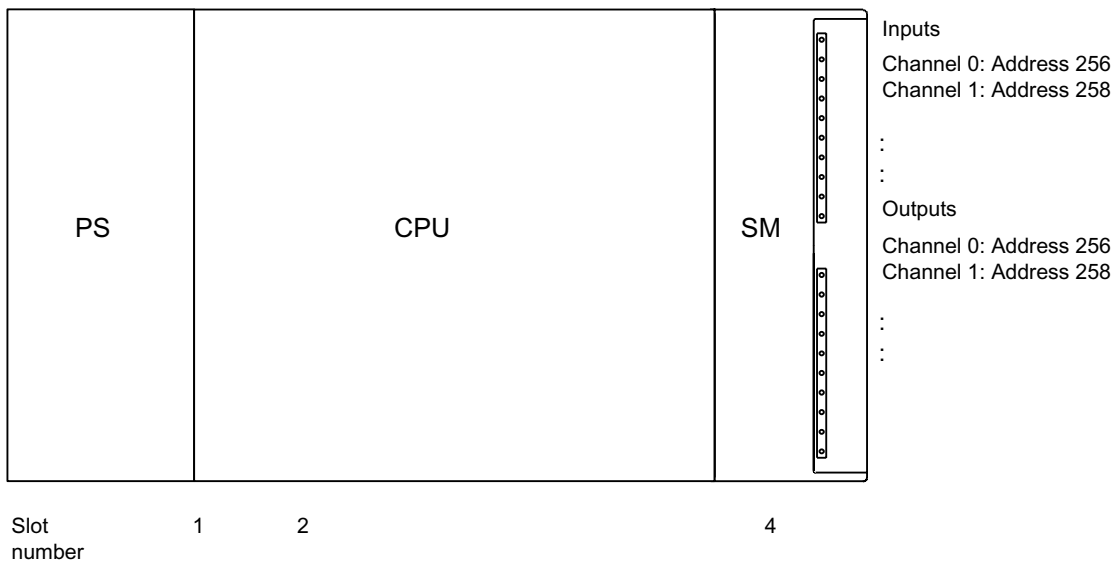

Figure 7-1 I/O addresses of an analog module at slot 4

## 7.2.4 Addressing the integrated I/Os of CPU 31xC

### CPU 312C

Addresses of the integrated I/Os of this CPU:

Table 7- 1 Integrated I/Os of CPU 312C

Inputs / outputs	Default addresses	Remarks
10 digital inputs	124.0 to 125.1 of which 8 Inputs are for technological functions: 124.0 to 124.7	All digital inputs can be assigned an interrupt function.  Optional technological functions: <ul style="list-style-type: none"> <li>• Counting</li> <li>• Frequency measurement</li> <li>• Pulse width modulation</li> </ul>
6 digital outputs	124.0 to 124.5 of which 2 inputs are for technological functions: 124.0 to 124.1	

### CPU 313C

Addresses of the integrated I/Os of this CPU:

Table 7- 2 Integrated I/Os of CPU 313C

Inputs / outputs	Default addresses	Comments
24 digital inputs	124.0 to 126.7 of which 12 inputs are for technological functions: 124.0 to 125.0 125.4 to 125.6	All digital inputs can be assigned an interrupt function.  Optional technological functions: <ul style="list-style-type: none"> <li>• Counting</li> <li>• Frequency measurement</li> <li>• Pulse width modulation</li> </ul>
16 digital outputs	124.0 to 125.7 of which 3 inputs are for technological functions: 124.0 to 124.2	
4+1 analog inputs	752 to 761	
2 analog outputs	752 to 755	

### CPU 313C-2 PtP and CPU 313C-2 DP

Addresses of the integrated I/Os of these CPUs:

Table 7- 3 Integrated I/Os of CPU 313C-2 PtP/DP

Inputs / outputs	Default addresses	Comments
16 digital inputs	124.0 to 125.7 of which 12 inputs are for technological functions: 124.0 to 125.0 125.4 to 125.6	All digital inputs can be assigned an interrupt function.  Optional technological functions: <ul style="list-style-type: none"> <li>• Counting</li> <li>• Frequency measurement</li> <li>• Pulse width modulation</li> </ul>
16 digital outputs	124.0 to 125.7 of which 3 inputs are for technological functions: 124.0 to 124.2	

**CPU 314C-2 PtP and CPU 314C-2 DP**

Addresses of the integrated I/Os of these CPUs:

Table 7- 4 Integrated I/Os of CPU 314C-2 PtP/DP

Inputs / outputs	Default addresses	Comments
24 digital inputs	124.0 to 126.7 of which 16 inputs are for technological functions: 124.0 to 125.7	All digital inputs can be assigned an interrupt function.  Optional technological functions: <ul style="list-style-type: none"> <li>• Counting</li> <li>• Frequency measurement</li> <li>• Pulse width modulation</li> <li>• Positioning</li> </ul>
16 digital outputs	124.0 to 125.7 of which 4 inputs are for technological functions: 124.0 to 124.3	
4+1 analog inputs	752 to 761	
2 analog outputs	752 to 755	

**Special features**

You cannot influence outputs with transfer instructions if they are assigned to technological functions.

I/Os not configured for technological functions can be used as standard I/Os.

## 7.3 Addressing on PROFIBUS DP

### Overview

The corresponding DP slaves must be commissioned for operation on PROFIBUS DP in order to enable addressing of distributed I/O in the user program.

This commissioning includes

- the assignment of DP slaves to PROFIBUS addresses
- the assignment of slots or address ranges to the I/O modules in order to enable their addressing in the user program. Slots which do not contain user data are assigned diagnostics addresses.

This applies likewise when the CPU is operated as DP slave.

Further information about CPU operation in DP master or DP slave mode is available in the chapter Commissioning PROFIBUS DP.

### User-specific addressing of distributed PROFIBUS IO

Distributed PROFIBUS DP IO requires user-specific addressing.

Further information is available in the *User-specific addressing of modules* chapter.

### Addressing consistent user data areas

The table below shows items to be taken into consideration in terms of communication in a PROFIBUS DP master system when transferring I/O areas with "Total length" consistency.

<b>Rule for 1 byte to 32 bytes data consistency on PROFIBUS DP:</b>
---

<p>The address area of consistent data in the process image is automatically updated.</p> <p>You can also use SFC14 "DPRD_DAT" and SFC15 "DPWR_DAT" to read and write consistent data. SFC14 and SFC15 are required to read and write consistent data of address areas which are not available in the process image.</p> <p>The length of areas with "Total length" consistency accessed by the SFC must match the programmed range.</p> <p>Direct access to consistent areas is also possible (L PEW or T PAW, for example).</p> <p>PROFIBUS DP supports the transfer of up to 32 bytes of consistent data.</p>
--

## 7.4 Addressing on PROFINET

### Overview

The corresponding I/O devices must be commissioned for operation on PROFINET in order to enable addressing of distributed peripherals on PROFINET IO in the user program.

This commissioning includes

- the definitions of I/O device numbers and names
- the definition of I/O device names in order to enable the assignment of IP addresses and access to the IO devices by the CPU 31x PN/DP operated as IO controller.

---

#### Note

##### Name assignment at "Device replacement without removable medium"

If the functionality "Device replacement without removable medium" is configured in HW Config, IO devices can be replaced without the user having to assign a name. To do so, the IO device has to be reset to the state of delivery by using "Reset to factory setting".

---

- Address ranges are assigned to the input/output modules or slots/subslots so that they can be addressed from the user program. Slots which do not contain user data are assigned diagnostics addresses.

Further information about CPU operation as I/O controller is available in the chapter Commissioning PROFINET IO.

### User-specific addressing of distributed PROFINET IO

Distributed peripherals on PROFINET IO require user-specific addressing.

Further information is available in the *User-specific addressing of modules* chapter.

### Addressing consistent user data areas

The table below shows items to be taken into consideration in terms of communication in a PROFINET IO system when transferring I/O areas with "Total length" consistency.

<b>Rule for 1 byte to 254 bytes data consistency on PROFINET IO:</b>
--

The address area of consistent data in the process image is automatically updated.
--

You can also use SFC14 "DPRD_DAT" and SFC15 "DPWR_DAT" to read and write consistent data. SFC14 and SFC15 are required to read and write consistent data of address areas which are not available in the process image.
---

The length of areas with "Total length" consistency accessed by the SFC must match the programmed range.
--

Direct access to consistent areas is also possible (L PEW or T PAW, for example).
---

PROFINET IO supports the transfer of up to 254 bytes of consistent data.
--



# Commissioning

## 8.1 Overview

This section contains important notes on commissioning which you should strictly observe in order to avoid injury or damage to machines.

---

### Note

Your commissioning phase is determined primarily by your application, so we can only offer you general information, without claiming completeness of this topic.

---

### Reference

Note the information about commissioning provided in the descriptions of your system components and devices.

## 8.2 Commissioning procedure

### 8.2.1 Procedure: Commissioning the hardware

#### Hardware requirements

- S7-300 is installed
- S7-300 is wired

With networked S7-300, the following applies to the interfaces:

- MPI/ PROFIBUS
  - The MPI/PROFIBUS addresses are configured
  - The terminating resistors on the segments are enabled.
- PROFINET
  - The integrated PROFINET interface of CPU 31x PN/DP is configured in STEP 7 (IP address and device name are set in HW Config)
  - The CPU is connected to the subnet.

**Recommended procedure: Hardware**

The S7-300 system can be very large and extremely complex due to its modular structure and versatile expansion options. It is therefore inappropriate to initially start up an S7-300 with multiple racks and all inserted (installed) modules. Rather, we recommend a step-by-step commissioning procedure.

We recommend the following initial commissioning procedure for an S7-300:

Table 8- 1 Recommended commissioning procedure: Hardware

Tasks	Remarks	Information can be found
An installation and wiring check according to checklist	-	<i>in the chapter: Checklist for commissioning</i>
Disconnecting drive aggregates and control elements	This prevents negative effects on your system as a result of program errors.  Tip: By redirecting data from your outputs to a data block, you can always check the status at the outputs	-
Preparing the CPU	Connecting the PG	<i>in the chapter: Connecting the programming device (PG).</i>
Central unit (CU): commission the CPU and power supply, check the LEDs	Commission the CU with inserted power supply module and CPU. First, switch on the expansion devices (EMs) which are equipped with their own power supply module, and then switch on the power supply module of the CU.	<i>in the chapter: Initial power on</i>
	Check the LED displays on both modules.	<i>in the chapter: Debugging functions, diagnostics and troubleshooting</i>
Reset CPU memory and check the LEDs	-	<i>in the chapter: CPU memory reset by means of mode selector switch</i>
CU: commission the remaining modules	Insert further modules into the CU and commission these, working successively.	in the <i>Module specifications Manual</i>
Expansion module (EM): Connecting	Interconnect the CU with EMs as required: Insert only one send IM into the CU, and insert the matching receive IM into into the EM.	<i>in the chapter: Installation</i>
EM: Commissioning	Insert further modules into the EMs and commission these, working in successively.	See above.

 <b>DANGER</b>
<p>Proceed step-by-step. Do not go to the next step unless you have completed the previous one without error / error message.</p>

**Reference**

Important notes can also be found in the section *Debugging Functions, Diagnostics and Troubleshooting*.

**See also**

Procedure: Software commissioning (Page 131)

## 8.2.2 Procedure: Software commissioning

### Requirements

- You must have installed and wired up your S7-300.
- You are using the current programming package of STEP 7 in order to utilize the complete functional scope of your CPU.
- In case of networking of the S7-300 with MPI or PROFIBUS
  - The MPI/PROFIBUS addresses are configured
  - The terminating resistors on the segments are enabled
- In case of networking of the S7-300 with PROFINET
  - The integrated PROFINET interface of CPU 31x PN/DP is configured in STEP 7 (IP address and device names are set in HW Config)
  - The CPU is connected to the subnet.

---

#### Note

Observe the procedure for commissioning the hardware.

---

### Recommended procedure: Software

Table 8- 2 Recommended commissioning procedure - Part II: Software

Tasks	Remarks	Information can be found ...
<ul style="list-style-type: none"> <li>• Switch on the PG and run SIMATIC Manager</li> <li>• Download the configuration and the program to the CPU</li> </ul>	-	In the <i>STEP 7</i> Programming Manual
Debugging the I/Os	Helpful functions are here: <ul style="list-style-type: none"> <li>• Monitoring and controlling tags</li> <li>• Testing with program status</li> <li>• Forcing</li> <li>• Controlling outputs in STOP mode (PO enable)</li> </ul> <b>Tip:</b> Test the signals at the inputs and outputs using the simulation module SM 374, for example.	In the <i>STEP 7</i> Programming Manual <i>Chapter: Debugging functions, diagnostics and troubleshooting</i>
Commissioning PROFIBUS DP or Ethernet	-	<i>in the chapter: Commissioning PROFIBUS DP</i> <i>in the chapter: Configuring PROFINET interface X2</i>
Commissioning PROFINET IO		in the <i>PROFINET System Description</i> System Manual
Connect the outputs	Commissioning the outputs successively.	-

 **DANGER**

Proceed step-by-step. Do not go to the next step unless you have completed the previous one without error / error message.

**Reaction to errors**

React to errors as follows:

- Check the system with the help of the check list in the chapter below.
- Check the LED displays on all modules. For information on their meaning, refer to the chapters describing the relevant modules.
- If required, remove individual components to trace the error.

**Reference**

Important notes can also be found in the section *Debugging Functions, Diagnostics and Troubleshooting*.

**See also**

Procedure: Commissioning the hardware (Page 129)

## 8.3 Commissioning check list

**Introduction**

After you mounted and wired your S7-300, we advise you to check all previous steps once again.

The check list tables below are a guide for your examination of the S7-300. They also provide cross-references to chapters containing further information on the relevant topic.

**Racks**

Points to be examined are in the manual	S7-300: Installation in chapter
Are the rails mounted firmly to the wall, in the frame or in the cabinet?	Configuring, Installation
Have you maintained the free space required?	Configuring, Installation
Are the cable ducts installed properly?	Configuring
Is the air circulation OK?	Installing

### Concept of grounding and chassis ground

Points to be examined are in the manual	S7-300: Installation in chapter
Have you established a low-impedance connection (large surface, large contact area) to local ground?	Configuring, Appendix
Are all racks (rails) properly connected to reference potential and local ground (direct electrical connection or ungrounded operation)?	Configuring, Wiring, Appendix
Are all grounding points of electrically connected modules and of the load power supply units connected to reference potential?	Configuring, Appendix

### Module installation and wiring

Points to be examined are in the manual	S7-300: Installation in chapter
Are all modules properly inserted and screwed in?	Installing
Are all front connectors properly wired, plugged, screw-tightened or latched to the correct module?	Installation, Wiring

### Mains voltage

Points to be examined	S7-300: Installation in chapter	See manual; Section ...
Is the correct mains voltage set for all components?	Wiring	Module data

### Power supply module

Points to be examined	S7-300: Installation in chapter	See manual; Section ...
Is the mains plug wired correctly?	Wiring	-
Is mains voltage connected?	-	-

## 8.4 Commissioning the Modules

### 8.4.1 Inserting/Replacing a Micro Memory Card

#### SIMATIC Micro Memory Card (MMC) as memory module

The memory module used on your CPU is a SIMATIC Micro Memory Card. You can set up the SIMATIC Micro Memory Card as a load memory or a portable data medium.

---

**Note**

A SIMATIC Micro Memory Card must be inserted for CPU operation.

---

**Note**

The CPU goes into STOP and requests a memory reset when you remove the SIMATIC MMC while the CPU is in RUN state.

---

 **CAUTION**

Data on a SIMATIC Micro Memory Card can be corrupted if you remove the card while it is being accessed by a write operation. You may have to delete the SIMATIC Micro Memory Card using the PG or format it in the CPU if you remove it from the live system. DO NOT remove the SIMATIC Micro Memory Card when the system is in RUN state; always shut down power or set the CPU to STOP state in order to prevent any write access of a programming device. When the CPU is in STOP mode and you cannot not determine whether or not a PG is writing to the card (e.g. load/delete block), disconnect the communication lines.

 **WARNING**

Make sure that the SIMATIC Micro Memory Card to be inserted contains a user program which is suitable for the CPU (system). The wrong user program may have fatal processing effects.

### Inserting/replacing the SIMATIC Micro Memory Card

1. Switch the CPU to STOP mode.
2. Is a SIMATIC Micro Memory Card inserted?  
If yes, ensure that no write operations are running on the PG (such as loading a block).  
If you cannot ensure this state, disconnect all communication lines of the CPU.

Press the ejector and remove the SIMATIC MMC.

The frame of the module slot is equipped with an ejector for removing the SIMATIC MMC (see CPU 31xC and CPU 31x Manual, Technical Data *CPU31x Operator Control and Display Elements*).

You need a small screwdriver or ball-point pen to eject the SIMATIC Micro Memory Card.

3. Insert the ("new") SIMATIC MMC into the card slot with its beveled edge facing the ejector.
4. Carefully push the SIMATIC MMC into the CPU slot to engage the interlock.
5. Reset CPU memory (*see Resetting CPU memory by means of mode selector switch*)

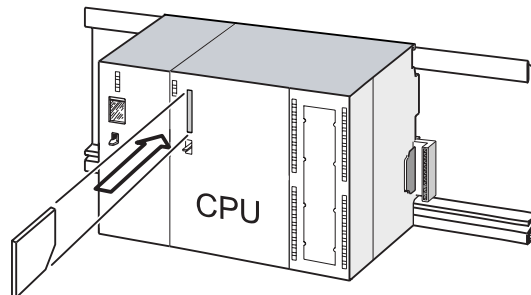

### Inserting and removing a SIMATIC MMC when CPU power is switched off

After you replaced a SIMATIC MMC in POWER OFF state, the CPUs

- automatically detect a physically identical SIMATIC MMC with changed content
- automatically detect a new MMC with contents to the previous SIMATIC MMC

It automatically performs a CPU memory reset after POWER ON.

### Reference

- Chapter *Properties of the SIMATIC Micro Memory Card*, CPU 31xC and CPU 31x Manual, Technical data
- Chapter *Technical data of the SIMATIC Micro Memory Card (MMC)*, CPU 31xC and CPU 31x Manual, Technical data

## 8.4.2 Initial turn-on

### Requirements

- You must have installed and wired up the S7-300.
- Insert the Micro Memory Card into the CPU
- Your CPU's mode selector switch must be set to STOP.

### Initial power on of a CPU with Micro Memory Card

Switch on the PS 307 power supply module.

#### Result:

- The 24 VDC LED on the power supply module is lit.
- The 5 VDC LED on the CPU
  - is lit.
  - The STOP LED flashes at 2 Hz when the CPU executes an automatic memory reset.
  - The STOP LED is lit after memory reset.



### 8.4.3 CPU memory reset by means of mode selector switch

#### When to reset CPU memory

You reset CPU memory

- in order to clear all retentive memory bits, timers and counters, and to initialize work memory with the start values of the retentive DBs in load memory.
- if the new retentive new memory bits, timers and counters downloaded to the CPU user program using the "Download user program to Memory Card" function are liable to cause unwanted reactions.

Reason: the "Download user program to Memory Card" function does not delete any retentive memory areas.

- when the CPU requests a memory reset; indicated by the STOP LED flashing at 0.5 Hz intervals

Table 8- 3 Possible reasons of a CPU request to reset memory

Causes of a CPU request to reset memory	Special features
The SIMATIC MMC has been replaced.	–
RAM error in CPU	–
Insufficient work memory for loading all user program blocks from a SIMATIC MMC.	CPU with inserted SIMATIC Micro Memory Card: Recursive request of a CPU memory reset. For further information on the behavior of the SIMATIC MMC during CPU memory reset, refer to the CPU 31xC and CPU 31x Manual, Technical data, <i>Memory Reset and Restart</i>
Attempts to load faulty blocks; if a wrong instruction was programmed, for example.	

#### How to reset memory

There are two ways to reset CPU memory:

CPU memory reset using the mode selector switch	CPU memory reset using the PG
... is described in this chapter.	... is only possible when CPU is in STOP mode (see <i>STEP 7 Online Help</i> ).

### Resetting CPU memory using the mode selector switch

The table below shows the steps in resetting CPU memory.

Table 8- 4 Procedure for CPU memory reset

Step	Reset CPU memory
1.	Turn the key to STOP position ①.
2.	Turn the key to MRES position Hold the key in this position until the STOP LED lights up for the second time and remains on (this takes 3 seconds). ② Now release the key.
3.	You must turn the key to MRES position again within 3 seconds and hold it there until the STOP LED flashes (at 2 Hz). ③ You can now release the switch. When the CPU has completed memory reset, the STOP LED stops flashing and remains lit. The CPU has reset the memory.

The procedure described earlier is only required to reset CPU memory when the CPU has not requested (indicated by slow flashing of the STOP LED) a memory reset. If the CPU requests a memory reset you only have to briefly set the mode selector switch to the MRES position in order to initiate the memory reset.

The figure below shows how to use the mode selector switch to reset CPU memory:

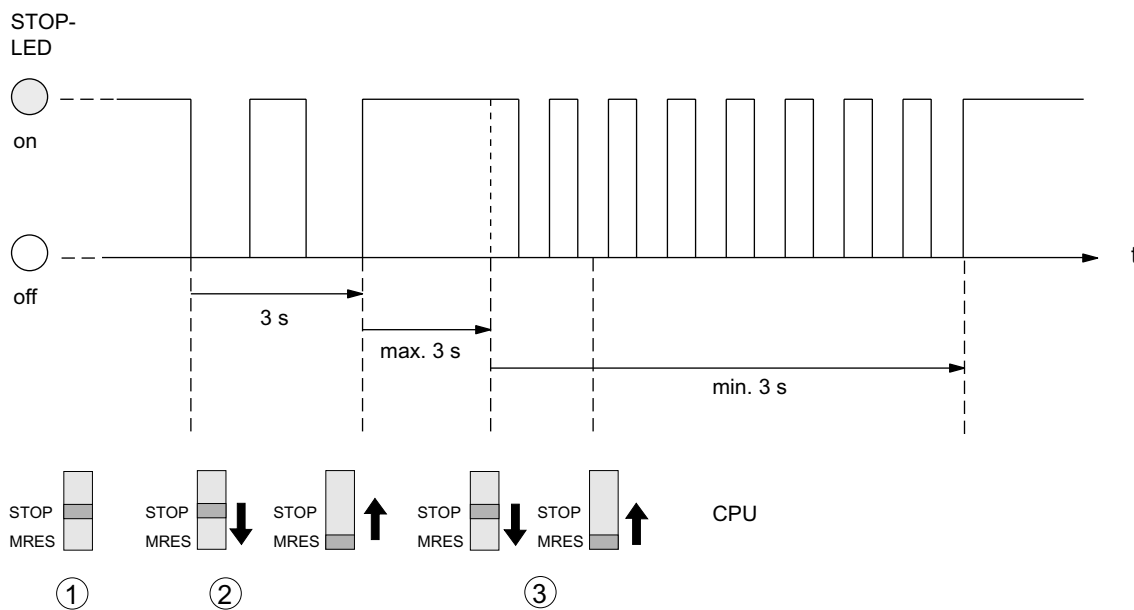

You may have to format the SIMATIC MMC if memory was successfully reset and the CPU once again requests a memory reset (see *Formatting the SIMATIC Micro Memory Card*).

### STOP LED does not flash during the memory reset

What should I do if the STOP LED does not flash during the memory reset or if other LEDs are lit?

1. You must repeat steps ② and ③.
2. If the CPU still does not reset memory, evaluate the diagnostic buffer of the CPU.

## What happens in the CPU during a memory reset

Table 8- 5 Internal CPU events on memory reset

Event	Action in CPU
CPU activities	1. The CPU deletes the entire user program in the main memory.
	2. The CPU deletes the retentive data.
	3. The CPU tests its own hardware.
	4. The CPU copies the runtime-relevant content of the SIMATIC Micro Memory Card (load memory) to work memory. <b>Tip:</b> If the CPU is unable to copy the contents from the SIMATIC MMC and requests a memory reset: <ul style="list-style-type: none"> <li>• Remove the SIMATIC Micro Memory Card.</li> <li>• Reset CPU memory</li> <li>• Read the diagnostic buffer.</li> </ul>
Memory contents after reset	The user program is once again transferred from the SIMATIC MMC to work memory. Memory utilization is indicated accordingly.
Data retained	Data in the diagnostics buffer. You can read the diagnostic buffer with the PG (see <i>STEP 7 Online Help</i> ).
	<ul style="list-style-type: none"> <li>• The MPI parameters (MPI address and highest MPI address, transmission rate, configured MPI addresses of CPs/FMs in an S7300).</li> <li>• Same applies to CPU 315-2 PN/DP /CPU 317 / CPU 319 if the MPI/DP interface of the CPU is programmed for operation as DP interface (PROFIBUS address, highest PROFIBUS address, baud rate, configured as active or passive interface).</li> </ul>
	Content of elapsed time counter

### Special feature: Interface parameters (MPI or MPI/DP interface)

The following parameters hold a special position when CPU memory is reset.

- Parameters of interface (MPI parameters or MPI-/DP parameters for MPI-/DP interfaces).

The table below describes which interface parameters remain valid after a CPU memory reset.

CPU memory reset ...	MPI/DP parameters
<b>with</b> inserted SIMATIC Micro Memory Card:	...the MPI parameters on the SIMATIC Micro Memory Card or integrated read-only load memory are valid. If this location does not contain any parameter data (SDB), the previously set parameters stay valid.
<b>without</b> inserted SIMATIC Micro Memory Card:	... are retained and valid.

### 8.4.4 Formatting the Micro Memory Card

#### Situations which require formatting of the SIMATIC Micro Memory Card:

- The SIMATIC Micro Memory Card module type is not a user module
- The SIMATIC Micro Memory Card is not formatted
- The SIMATIC Micro Memory Card is defective
- Invalid content of the SIMATIC Micro Memory Card  
The content of the SIMATIC Micro Memory Card has been marked invalid
- The "Download user program" operation was interrupted as a result of Power Off.
- The "Write to EPROM" operation was interrupted as a result of Power Off.
- Error when evaluating the module content during CPU memory reset.
- Formatting error, or formatting failed.

If one of these errors has occurred, the CPU prompts you for yet another memory reset, even after a memory reset operation has been performed. The contents of the SIMATIC MMC are retained until it is formatted, unless the "Download user program" or "Write to EPROM" operation was interrupted due to Power Off.

The SIMATIC Micro Memory Card is only formatted if a specific reason is given (see above). It is not formatted, for example, when the CPU requests a memory reset after module replacement. In this case, a switch to MRES triggers a normal memory reset for which the module content remains valid.

#### How to format your SIMATIC Micro Memory Card

If the CPU has requested a memory reset (STOP LED flashing slowly) you can format the SIMATIC MMC using the mode selector switch as described below:

1. Toggle the switch to the MRES position and hold it there until the STOP LED lights up and remains on (after approx. 9 seconds).
2. Within the next three seconds, release the switch and toggle it once again to MRES position. The STOP LED flashes to indicate that formatting is in progress.

---

#### Note

Always perform these steps within the specified time, for the SIMATIC Micro Memory Card will otherwise not be formatted and returns to memory reset status.

---

#### See also

CPU memory reset by means of mode selector switch (Page 137)

## 8.4.5 Connecting the programming device (PG)

### 8.4.5.1 Connect PG/PC to the integrated PROFINET interface of the CPU 31x PN/DP

#### Requirement

- CPU with integrated PROFINET interface (CPU 319-3 PN/DP, for example)
- PG/PC with network card

#### Connect PG/PC to the integrated PROFINET interface of the CPU 31x PN/DP

1. Connect the PG/PC to a switch, using a TP patch cable ①.
2. In the same way, connect the switch to the integrated PROFINET interface of your CPU ②.

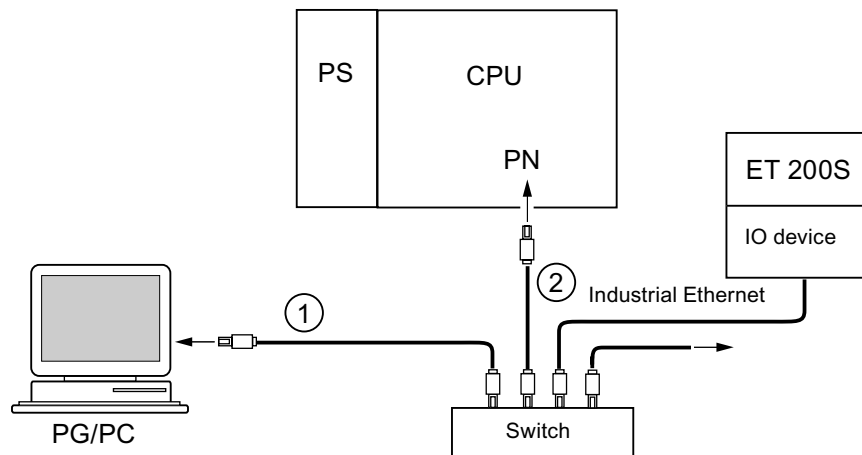

#### Result

You connected the PG/PC to the integrated PROFINET interface of the CPU.

#### Tip

Using an Ethernet crossover cable, you can also connect your PG/PC directly to the integrated PROFINET interface of the CPU 31x PN/DP.

#### Reference

- For information on PROFINET, refer to the *PROFINET System Description*.
- For information on passive network components such as switches, refer to the *SIMATIC NET manual: Twisted Pair and Fiber-Optic Networks*.

#### See also

Configuring and commissioning the PROFINET IO system (Page 166)

### 8.4.5.2 Connecting the PG to a node

#### Requirement

The PG must be equipped with an integrated MPI interface or an MPI card in order to connect it via MPI.

#### Connecting a PG to the integrated MPI interface of the CPU

Interconnect the PG with the MPI interface of your CPU by way of a PG patch cable ①. You can use a self-made PROFIBUS bus cable with bus connectors. The figure below illustrates the connection between the PG and the CPU

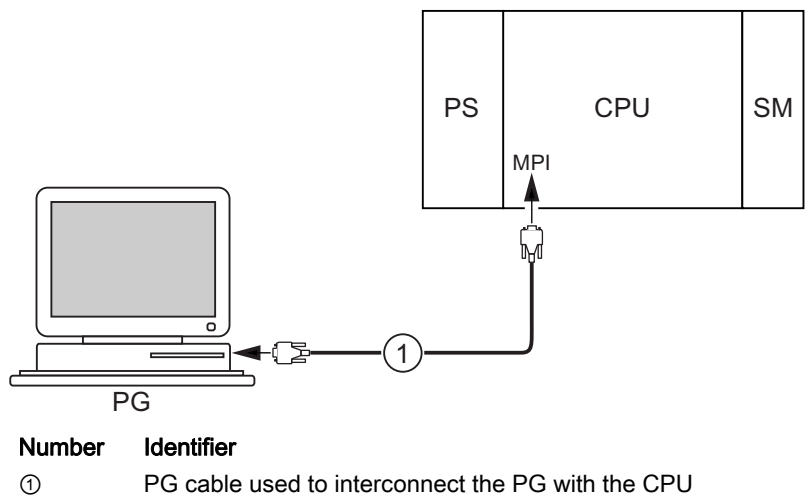

#### Procedure for PROFIBUS DP

The procedure is basically the same, if the CPU interface is set to PROFIBUS DP mode

### 8.4.5.3 Connecting the PG to several nodes

#### Requirements

The PG must be equipped with an integrated MPI interface or an MPI card in order to connect it to an MPI.

#### Connecting the PG to several nodes

Use bus connectors to connect a PG which is permanently installed on the MPI subnet to the other nodes of the MPI subnet.

The figure below shows two networked S7-300s which are interconnected by means of bus connectors.

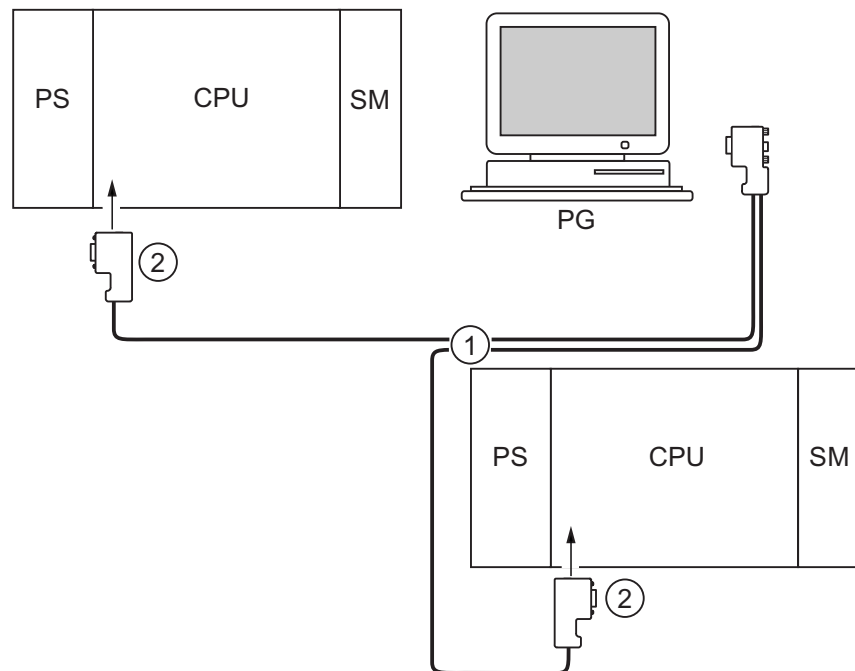

Number	Identifier
①	PROFIBUS bus cable
②	Connector with enabled terminating resistor

### 8.4.5.4 Using the PG for commissioning or maintenance

#### Requirement

The PG must be equipped with an integrated MPI interface or an MPI card in order to connect it to an MPI.

#### Using the PG for commissioning or maintenance

Use a stub cable to connect the commissioning and maintenance PG to the other subnet nodes. The bus connector of these nodes must be equipped with a PG socket.

The figure below shows the interconnection of two networked S7-300 and a PG.

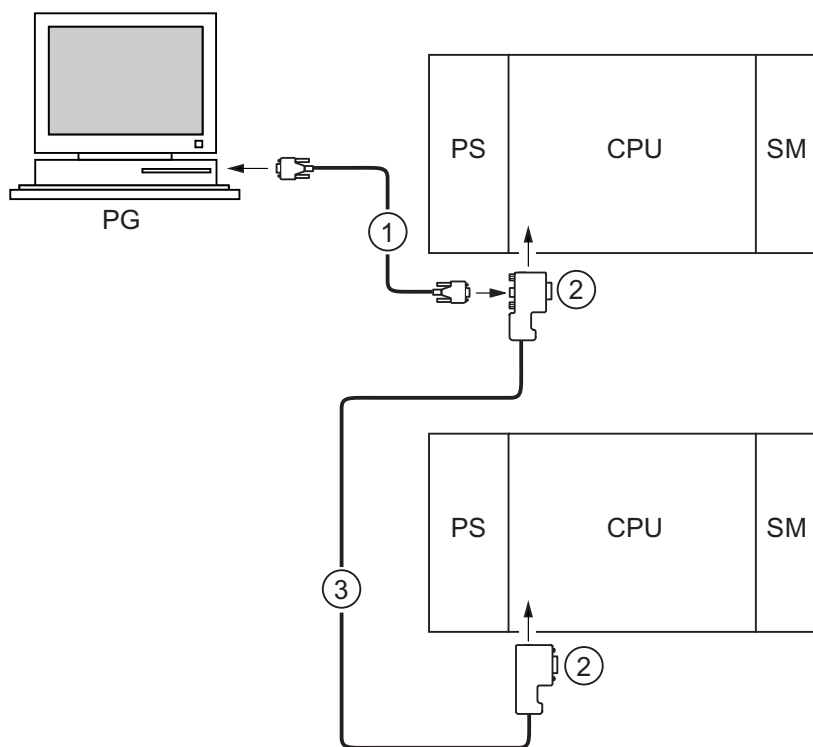

Number	Identifier
①	Stub cable used to interconnect the PG with the CPU
②	Connectors with enabled terminating resistors
③	PROFIBUS bus cable used to network both CPUs



### **MPI addresses for service PGs**

If there is no stationary PG, we recommend:

To connect a PG to an MPI subnet with "unknown" node addresses, set the following addresses on the service PG:

- MPI address: 0
- Highest MPI address: 126

IN STEP 7, you then determine the highest MPI address on the MPI subnet and match the highest MPI address in the PG to that of the MPI subnet.

### **See also**

Procedure: Commissioning the hardware (Page 129)

Procedure: Software commissioning (Page 131)

8.4.5.5 Connecting a PG to ungrounded MPI nodes (not CPU 31xC)

Requirement

The PG must be equipped with an integrated MPI interface or an MPI card in order to connect it to an MPI.

Connecting a PG to ungrounded nodes on an MPI subnet (not CPU 31xC)

Connecting a PG to ungrounded nodes

Always use an ungrounded PG to connect to ungrounded MPI subnet nodes or to ungrounded S7-300 PLCs.

Connecting a grounded PG to the MPI

You want to operate with ungrounded nodes. If the MPI at the PG is grounded, you must interconnect the nodes and the PG with an RS485 repeater. You must connect the ungrounded nodes to bus segment 2 if the PG is connected to bus segment 1 (terminals A1 B1) or to the PG/OP interface (refer to chapter 9 in the *Module Data Manual*).

The figure below shows an RS485 repeater as interface between grounded and ungrounded nodes of an MPI subnet.

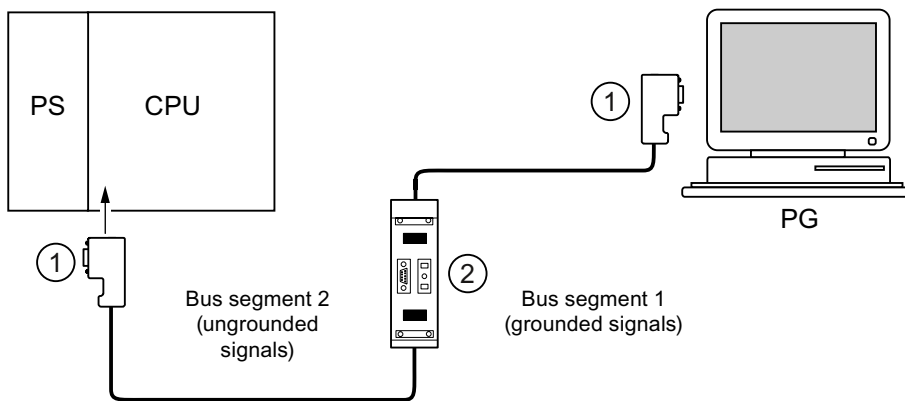

Number Identifier

- ① Connectors with enabled terminating resistors
- ② RS485 Repeaters, with activated terminating resistors

See also

- PROFINET cable lengths and network expansion (Page 80)
- Network components of MPI/DP and cable lengths (Page 59)

## 8.4.6 Starting SIMATIC Manager

### Introduction

SIMATIC Manager is a GUI for online/offline editing of S7 objects (projects, user programs, blocks, hardware stations and tools).

The SIMATIC Manager lets you

- manage projects and libraries,
- call STEP 7 tools,
- access the PLC (AS) online,
- edit Memory Cards.

### Starting SIMATIC Manager

After installation, the **SIMATIC Manager** icon appears on the Windows desktop, and the Start menu contains entry **SIMATIC Manager** under **SIMATIC**.

1. Run SIMATIC Manager by double-clicking the icon, or from the Start menu (same as with all other Windows applications).

### User interface

A corresponding editing tool is started up when you open the relevant objects. You start the program editor by double-clicking the program block you want to edit (object-oriented start).

### Online Help

The online help for the active window is always called by pressing F1.

### 8.4.7 Monitoring and modifying I/Os

#### The "Monitor and modify tags" tool

The STEP 7 "Monitor and modify tags" tool lets you:

- monitor program tags in any format
- edit the tag status or data in the CPU (modifying).

#### Creating a tag table

You have two options of creating a tag table (VAT):

- in the LAD / FBD / STL editor by selecting the **PLC > Monitor/Modify Variables** command  
This table is also available directly online.
- in SIMATIC Manager with the **Blocks** container open via menu item **Insert New Object > Variable table**

This table created offline can be saved for future retrieval. You can also test it after switching to online mode.

#### VAT structure:

In the VAT, every address to be monitored or modified (e.g. inputs, outputs) occupies one row.

The meaning of the VAT columns is as follows:

Column text	This field ...
Address	contains the absolute address of the tag
Icon	contains the symbolic descriptor of the tag This is identical to the specification in the Symbol Table.
Symbol comment	shows the symbol comment of the Symbol Table
Status format	contains the default format setting, e.g. HEX. You can change the format as follows: <ul style="list-style-type: none"> <li>• right-click in the format field. The Format List opens.</li> <li>or</li> <li>• left-click in the format field until the relevant format appears</li> </ul>
Status value	shows the content of the tag at the time of update
Modify value	is used to enter the new tag value (modify value)

#### Monitor tag

You have two options for monitoring tags:

- updating the status values once via menu item **Tag > Update Status Values**  
or
- continuous update of status values via menu item **Tag > Monitor**

## Modifying tags

To modify tags , proceed as follows:

1. Left-click the field **Modify value** of the relevant tag.
2. Enter the modify value according to the data type.
3. To update modify values once, select the menu item **Tag > Activate Modify Value**.

or

Enable modify values permanently via menu item **Tag > Modify**.

4. In the **Monitor** test function, verify the modify value entry in the tag.

### Is the modify value valid?

You can disable the modify value entered in the table. An invalid value is displayed same as a comment. You can re-enable the modify value.

Only valid modify values can be enabled.

## Setting the trigger points

### Trigger points:

- The "Trigger point for monitoring" determines the time of update for values of tags to be monitored.
- The "Trigger point for modifying" determines the time for assigning the modify values to the tags to be modified.

### Trigger condition:

- The "Trigger condition for monitoring" determines whether to update values once when the trigger point is reached or continuously every time the trigger point is reached.
- The "Trigger condition for modifying" determines whether to assign modify values once or permanently to the variable to be modified.

You can customize the trigger points using the tool "Monitor and modify tag" in the menu item **Tag > Set Trigger ...** .

### Special features

- If "Trigger condition for monitoring" is set to **once** , the menu items **Tag > Update Status Values** or **Tag > Monitor** have the same effect, namely a single update.
- If "Trigger condition for modifying" is set to **once** , the menu items **Tag > Update Status Values** or **Tag > Modify** have the same effect, namely a single assignment.
- If trigger conditions are set to **permanent** , the said menu items have different effects as described above.
- If monitoring and modifying is set to the same trigger point, monitoring is executed first.
- If **Process mode** is set under **Debug > Mode**, values are not cyclically updated when **permanent modification** is set.  
Remedy: Use the **Force** test function.

### Saving/opening the variable table

#### Saving the VAT

1. After aborting or completing a test phase, you can save the variable table to memory. The name of a variable table starts with the letters VAT, followed by a number from 0 to 65535; e.g. VAT5.

#### Opening VAT

1. Select the menu item **Table > Open**.
2. Select the project name in the **Open** dialog.
3. In the project window below, select the relevant program and mark the **Blocks** container.
4. In the block window, select the desired table.
5. Confirm with **OK**.

### establishing a connection to the CPU

The variables of a VAT represent dynamic quantities of a user program. In order to monitor or modify variables it is required to establish a connection to the relevant CPU. Every variable tables can be linked to another CPU.

In menu item **PLC > Connect to ...**, establish a connection to one of the following CPUs:

- configured CPU
- directly connected CPU
- available CPU ...

The table below lists the display of variables.

CPUs	The CPU variables are displayed, ...
configured CPU	in their S7 program (Hardware Station) in which the VAT is stored.
directly connected CPU	that is connected directly to the PG.
available CPU.	that is selected in the dialog window. Use the menu items <b>PLC &gt; Connect to ... &gt; Available CPU ...</b> to connect to an available CPU. This can be used to connect to any CPU available on the network.

### Modifying outputs in CPU STOP mode

The function **Enable PO** resets the output disable signal for the peripheral outputs (PO), thus enabling modifying of the PO in CPU STOP mode.

In order to enable the POs, proceed as follows:

1. In menu item **Table > Open the variable table (VAT)**, open the VAT that contains the PO you want to modify, or activate the window containing the corresponding VAT.
2. To modify the PO of the active VAT, select the CPU connection in menu command **PLC > Connect to ...**.
3. Use menu command **PLC > Operating Mode** to open the **Operating Mode** dialog and switch the CPU to STOP mode.
4. Enter your values in the "Modify value" column for the PO you want to modify.

Examples:

```
PO: POB 7  modify value: 2#0100 0011
POW 2   W#16#0027
POD 4   DW#16#0001
```

5. Select **Variable > Enable PO** to set "Enable PO" mode.
6. Modify the PO by selecting **Variable > Activate Modify Values**. "Enable PO" mode remains active until reset by selecting **Variable > Enable PO** once again.  
"Enable PO" is also terminated when the connection to the PG goes down.
7. Return to step 4 if you want to set new values.

---

#### Note

For example, a message pops up to indicate a CPU mode transition from STOP to RUN or START-UP.

A message also pops up when the "Enable PO" function is set while the CPU is in RUN mode.

---

## 8.5 Commissioning PROFIBUS DP

### 8.5.1 Commissioning PROFIBUS DP

#### Requirements

Requirements for commissioning a PROFIBUS DP network:

- A PROFIBUS DP network is installed.
- You have configured the PROFIBUS DP network using STEP 7 Standard Package and have assigned a PROFIBUS DP address and the address space to all the participants.
- Note that you must also set address switches at some of the DP slaves (see the description of the relevant DP slave).
- Software requirements are shown in the table below, based on the CPU used:

Table 8- 6 Software requirements

CPU	Order No.	Software required
313C-2 DP	6ES7313-6CF03-0AB0	STEP 7 V 5.2. or higher + SP1 + HSP <i>COM PROFIBUS</i> V 5.0 or higher
314C-2 DP	6ES7314-6CG03-0AB0	
315-2 DP	6ES7315-2AG10-0AB0	STEP 7 V5.2 + SP1 + HSP or higher
315-2 PN/DP	6ES7315-2EH13-0AB0	STEP 7 V5.4 + SP1 + HSP or higher
317-2 DP	6ES7317-2AJ10-0AB0	STEP 7 V5.2 + SP1 + HSP or higher
317-2 PN/DP	6ES7317-2EK13-0AB0	STEP 7 V 5.4 + SP2 or higher
319-3 PN/DP	6ES7318-3EL00-0AB0	STEP 7 V 5.4 + SP4 or higher

#### DP address areas of the CPUs

Table 8- 7 DP address areas of the CPUs

Address area	313C-2 DP 314C-2 DP	315-2 DP	315-2 PN/DP	317-2 DP 317-2 PN/DP	319-3 PN/DP
Entire address area of inputs and of outputs	1024 bytes	2048 bytes	2048 bytes	8192 bytes	8192 bytes
of these in the process image, for inputs and outputs respectively:	max. 128 bytes	max. 128 bytes	max. 2048 bytes	max. 2048 bytes	Max. 4096 bytes
• Default	128 bytes <sup>1</sup>	128 bytes <sup>1</sup>	128 bytes	256 bytes	256 bytes

<sup>1</sup> default cannot be changed



## DP diagnostics addresses

DP diagnostic addresses occupy 1 byte per DP master and DP slave in the input address area. For example, at these addresses DP standard diagnostics can be called for the relevant node (LADDR parameter of SFC 13). The DP diagnostic addresses are specified in your configuration. If you do not specify any DP diagnostic addresses, STEP 7 assigns these DP diagnostic addresses in ascending order, starting at the highest byte address.

In the case of a CPU 31xC-2 DP, CPU 31x-2 DP or CPU 31x PN/DP assigned as a master, two different diagnostic addresses must be assigned for S7 slaves.

- Diagnostic address of the slave (address for slot 0)

At this address all slave events are reported in the DP master (Node representative), e.g. Node failure.

- Diagnostic address of the module (address for slot 2)

All module (CPU 313C-2 DP as I-Slave, for example) events are reported in the master (OB82) at this address. With a CPU as DP Slave, for example, diagnostic interrupts for operating mode transitions are reported at this address.

## See also

Connecting the PG to a node (Page 142)

Connecting the PG to several nodes (Page 143)

## 8.5.2 Commissioning the CPU as DP master

### Requirements for commissioning

- The PROFIBUS subnet has been configured.
- The DP slaves are ready for operation (see relevant DP slave manual).
- In order to operate the MPI/DP interface as DP interface it must be configured accordingly (only CPU 315-2 PN/DP/ CPU 317 and CPU 319).
- You must configure the CPU as DP master prior to commissioning. That is, in STEP 7 you have to
  - configure the CPU as a DP master,
  - assign a PROFIBUS address to the CPU,
  - assign a master diagnostic address to the CPU,
  - integrate the DP slaves into the DP master system.

Is the DP CPU a DP slave?

If so, this DP slave appears in the PROFIBUS-DP catalog as **configured station**. In the DP master, assign a slave diagnostic address to this DP slave CPU. You must interconnect the DP master with the DP slave CPU and specify the address areas for data exchange with the DP slave CPU.

### Commissioning

Commission the DP CPU as a DP master in the PROFIBUS subnet as follows:

1. Download the PROFIBUS subnet configuration created with STEP 7 (preset configuration) from the PG to the DP CPU.
2. Switch on all of the DP slaves.
3. Switch the DP CPU from STOP to RUN.

### Startup of DP CPU as DP master

During startup, the DP CPU checks the configured preset configuration of its DP master system against the actual configuration.

If preset configuration = actual configuration, the CPU switches to RUN mode.

If the preset configuration ≠ to the actual configuration, the configuration of parameter **Startup if preset configuration ≠ actual configuration** determines the startup behavior of the CPU.

Startup when the preset configuration ≠ actual configuration = yes (default setting)	Startup when the preset configuration ≠ actual configuration = no
DP CPU switches to RUN. (BUSF LED flashes if any of the DP slaves cannot be addressed)	DP CPU remains in STOP mode, and the BUS LED flashes after the set <b>Monitoring time for transfer of parameters to modules</b> .  The flashing BUSF LED indicates that at least one DP slave cannot be accessed. In this case, check whether all DP slaves are switched on or correspond with your configuration, or read out the diagnostic buffer with STEP 7.

### Recognizing the operating state of DP slaves (Event recognition)

The table below shows how the DP CPU operating as a DP master recognizes operating mode transitions of a CPU operating as a DP slave or data exchange interruptions.

Table 8- 8 Event recognition by CPUs 31xC-2 DP / 31x-2 DP / 31x PN/DP operating as DP master

Event	What happens in the DP master?
Bus interruption (short circuit, connector removed)	<ul style="list-style-type: none"> <li>• Call of OB 86 with the message <b>Station failure</b> (coming event; diagnostic address of the DP slave assigned to the DP master)</li> <li>• With I/O access: call of OB 122 (I/O access error)</li> </ul>
DP slave: RUN → STOP	<ul style="list-style-type: none"> <li>• Call of OB 82 with the message <b>Module error</b> (incoming event; diagnostic address of the DP slave assigned to the DP master; Variable OB82_MDL_STOP=1)</li> </ul>
DP slave: STOP → RUN	<ul style="list-style-type: none"> <li>• Call of OB 82 with the message <b>Module OK</b> (outgoing event; diagnostic address of the DP-Slave assigned to the DP master; Variable OB82_MDL_STOP=0)</li> </ul>

**Tip:**

When commissioning the CPU as DP master, always program OB82 and OB86. This helps you to recognize and evaluate data exchange errors or interruption.

### Programming, status/control via PROFIBUS

As an alternative to the MPI interface, you can program the CPU or execute the PG's status and control functions via the PROFIBUSDP interface.

---

#### Note

The use of Status and Control function via the PROFIBUS-DP interface extends the DP cycle.

---

### Constant Bus Cycle Time

This is a property of PROFIBUS DP. The "Constant bus cycle time" function ensures that the DP master always starts the DP bus cycle within a constant interval. From the perspective of the slaves, this means that they receive their data from the master at constant time intervals.

In STEP 7 V 5.x or higher you can configure constant bus cycle times for PROFIBUS subnets. Details on constant bus cycle times are found in the *STEP 7 Online Help*.

### Isochronous updating of process image partitions

SFC126 "SYNC\_PI" is used for the isochronous update of the process image partition of inputs. An application program which is interconnected with a DP cycle (by means of OB61) can use this SFC for consistent updates of data recorded in the process image partition of inputs in synchronism with this cycle. SFC126 accepts interrupt control and can only be called in OB61.

SFC 127 "SYNC\_PO" is used for the isochronous update of the process image partition of outputs. An application program which is interconnected to a DP cycle can use the SFC for the consistent transfer of the computed output data of a process image partition of outputs to the I/O in synchronism with this cycle. SFC 127 accepts interrupt control and can only be called in OB 61.

The SFCs 126 and 127 are described in the *STEP 7 Online Help* and in the *System Software S7-300/400, System and Standard Functions Reference Manual*.

The 315-2 PN/DP, 317 DP, 317-2 PN/DP and 319-3 PN/DP CPUs support isochronous mode. CPUs with two DP interfaces (CPU 317-2 DP and CPU 319-3 PN/DP) only support isochronous mode on their second (DP) interface.

### Reference

For further information on isochronous mode, refer to the *"Isochronous mode"* Manual.

### Time synchronization

Further information about time synchronization on PROFIBUS DP is available in the chapter *Interfaces > PROFIBUS DP*.

## Sync/Freeze

The SYNC control command is used to set sync mode on the DP slaves of selected groups. In other words, the DP master transfers current output data and instructs the relevant DP slaves to freeze their outputs. The DP slaves writes the output data of the next output frames to an internal buffer; the state of the outputs remains unchanged.

Following each SYNC control command, the DP slaves of the selected groups transfer the output data stored in the internal buffer to the process outputs.

The outputs are only updated cyclically again after you transfer the UNSYNC control command using SFC11 "DPSYC\_FR".

The FREEZE control command is used to set the relevant DP slaves to Freeze mode, in other words, the DP master instructs the DP slaves to freeze the current state of the inputs. It then transfers the frozen data to the input area of the CPU.

Following each FREEZE control command, the DP slaves freeze the state of their inputs again.

The DP master receives the current state of the inputs cyclically again not until you have sent the UNFREEZE control command with SFC11 "DPSYC\_FR".

The SFCs 11 are described in the corresponding *STEP 7 Online Help* and in the *System Software S7-300/400, System and Standard Functions Reference Manual*.

## Startup of the DP master system

<b>CPU 31xC-2 DP / 31x-2 DP / 31x PN/DP is DP master</b>
The <b>Parameter transfer to modules</b> parameter is also used to define the startup monitoring time for DP slaves.
That is, the DP slaves must startup and must have received all parameters from the CPU (as DP master) within the defined time.

## PROFIBUS address of the DP master

For the DP CPU, you **must not set "126"** as a PROFIBUS address.

### 8.5.3 Commissioning the CPU as DP Slave

#### Requirements for commissioning

- The DP master is configured and programmed.
- If the MPI/DP interface of your CPU must be a DP interface, you must configure the interface as DP interface.
- Prior to commissioning, you must set the relevant parameters and configure the DP CPU for operation as DP slave. That is, in STEP 7 you have to
  - "power on" the CPU as DP slave,
  - assign a PROFIBUS address to the CPU,
  - assign a slave diagnostic address to the CPU,
  - specify whether the DP master is an S7 DP master or another DP master,
  - specify the address areas for data exchange with the DP master.
- All other DP slaves are programmed and configured.

#### GSD files

If you are working on an IM 308-C or third party system, you require a GSD file in order to be able to configure the DP CPU as a DP slave in a DP master system.

COM *PROFIBUS V*4.0 or later includes this GSD file.

When working with an older version or another configuration tool, you can download the GSD file at:

- On the Internet at <http://www.automation.siemens.com/csi/gsd>  
or
- via modem from the IneterSfacesCenter Fürth, Germany, telephone number +49 911 737972

---

#### Note

This note applies to the CPUs 31xC-2 DP, CPU 315, CPU 317 and CPU 319.

If you wish to use the CPU as a standard slave using the GSD file, you must not set the Commissioning / Test mode check box on the DP interface properties dialog box when you configure this slave CPU in STEP 7.

---

#### Configuration and parameter assignment message frame

STEP 7 assists you during configuration and parameter assignment of the DP CPU. Should you require a description of the configuration and parameter assignment frame, in order to use a bus monitor for example, you can find it on the Internet at [http://www.siemens.com/automation/csi\\_es\\_WW/product](http://www.siemens.com/automation/csi_es_WW/product) under entry ID 1452338.

## Commissioning

Commission the DP CPU as a DP slave in the PROFIBUS subnet as follows:

1. Switch on power, but hold the CPU in STOP mode.
2. First, switch on all other DP masters/slaves.
3. Now switch the CPU to RUN mode.

## Startup of DP CPU as DP slave

When the DP-CPU is switched to RUN mode, two mutually independent operating mode transitions are executed:

- The **CPU** switches from STOP to RUN mode.
- The CPU starts data exchange with the DP master via the **PROFIBUS DP interface**.

## Recognizing the Operating State of the DP master (Event Recognition)

The table below shows how the DP CPU operating as a DP slave recognizes operating state transitions or data exchange interruptions.

Table 8- 9 Event recognition by CPUs 31xC-2 DP / 31x-2 DP / 31x PN/DP operating as DP slave

Event	What happens in the DP slave?
Bus interruption (short circuit, connector removed)	<ul style="list-style-type: none"> <li>• Call of OB 86 with the message <b>Station failure</b> (coming event; diagnostic address assigned to the DP slave)</li> <li>• With I/O access: Call of OB 122 (I/O access error)</li> </ul>
DP master. RUN → STOP	<ul style="list-style-type: none"> <li>• Call of OB 82 with the message <b>Module error</b> (coming event; diagnostic address assigned the DP slave; variable OB82_MDL_STOP=1)</li> </ul>
DP master STOP → RUN	<ul style="list-style-type: none"> <li>• Call of OB 82 with the message <b>Module OK</b> (outgoing event; diagnostic address assigned to the DP slave; variable OB82_MDL_STOP=0)</li> </ul>

### Tip:

When commissioning the CPU as DP slave, always program OB82 and OB86. This helps you to recognize and evaluate the respective operating states or data exchange errors.

## Status/control, programming via PROFIBUS

As an alternative to the MPI interface, you can program the CPU or execute the PG's status and control functions via the PROFIBUS DP interface.

### Note

The execution of status and control function via PROFIBUS DP interface extends the DP cycle.

### User data transfer by way of transfer memory

The DP CPU operating as intelligent DP slave provides a transfer memory for PROFIBUS DP. User data are always exchanged between the CPU (DP slave) and the DP master by way of this transfer memory. You can configure up to 32 address areas for this function.

That is, the DP master writes its data to these transfer memory address areas, the CPU reads these data in the user program, and vice versa.

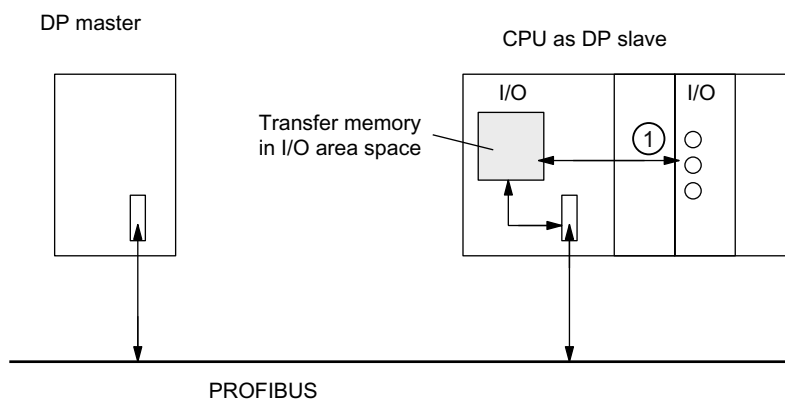

Number	Description
①	The functions which control data exchange between transfer memory and the distributed I/O of the slave CPU must be implemented in the user program. The DP master cannot access this I/O directly.

### Address areas of transfer memory

In STEP 7, configure the I/O address areas:

- You can configure up to 32 I/O address areas.
- Maximum length per address area is 32 bytes.
- You can configure a maximum of 244 input bytes and 244 outputs bytes.

The table below shows the principle of address areas. You can also find this figure in the STEP 7 configuration.

Table 8- 10 Configuration example for the address areas of transfer memory

	Type	Master address	Type	Slave address	Length	Unit	Consistency
1	I	222	O	310	2	BYTE	Unit
2	O	0	I	13	10	Word	Total length
:							
32							
	Address areas in the DP master CPU		Address areas in the DP slave CPU		These parameters of the address areas must be the same for DP master and DP slave.		



## Sample program

Below you will see a small sample program for data exchange between the DP master and the DP slave. The addresses used in the example are found in the table above.

In the DP slave CPU				In the DP master CPU			
L	2						
							//Data preparation in the DP slave
T	MB	6					
L	IB	0					
T	MB	7					
L	MW	6					//Transfer data to DP master
T	PQW	310					
				L	PIB	222	//process received data in the DP master
				T	MB	50	
				L	PIB	223	
				L	B#16#3		
				+	I		
				T	MB	51	
				L	10		//Data preparation in the DP master
				+	3		
				T	MB	60	
				CALL	SFC	15	//Send data to DP slave
					LADDR:=	W#16#0	
					RECORD:=		//In the user program of the masters
					P#M60.0	Byte20	//a block of 20 bytes lengths starting at MB60
							//is written consistently to the output area
							//PAB0 to PAB19
							//(transfer area from master to slave)
					RET_VAL:=	MW 22	
CALL	SFC	14					//Data received from DP master
							//The slave reads I/O bytes PEB13 to PEB32 (transferred data from master) consistently and saves these to MB30 to MB49
					LADDR:=	W#16#D	
					RET_VAL:=	MW 20	
					RECORD:=	P#M30.0	byte 20
L	MB	30					//Further processing of received data
L	MB	7					
+	I						
T	MW	100					

### Working with transfer memory

Note the following rules when working with the transfer memory:

- Assignment of address areas:
  - Input data of DP slaves are **always** output data of the DP master
  - Output data of DP slaves are **always** input data of the DP master
- The user can define these addresses. In the user program, access data with load/transfer instructions or with SFC 14 and SFC 15. You can also define addresses of the process image of inputs or outputs.
- The lowest address of specific address areas is their respective area start address.
- The length, unit and consistency of the address areas for DP master and DP slave must be identical.
- The master and slave addresses may differ in logically identical transfer memory (independent logical I/O address spaces in the master and slave CPU).

---

#### Note

Assign addresses from the I/O address area of the DP CPU to the transfer memory. You cannot use any addresses which have been assigned to transfer memory for other I/O modules.

---

### S5 DP master

If you use an IM 308-C as a DP master and the DP CPU as a DP slave, the following applies to the exchange of consistent data.

Use IM 308-C in the S5 control to program FB192 for enabling exchange of consistent data between the DP master and slave. With the FB192, the data of the DP CPU are only output or read out in a consistent block.

### S5-95 as DP master

If you set up an AG S5-95 for operation as DP master, you also have to set its bus parameters for the DP CPU as DP slave.

### User data transfer in STOP mode

User data is treated in transfer memory according to the STOP state of the DP master or DP slave.

- **The DP slave CPU goes into STOP:**

Data in transfer memory of the CPU are overwritten with "0" value, that is, the DP master reads "0" in direct data exchange mode.
- **The DP master goes into STOP:**

Current data in transfer memory of the CPU are retained and can be read by the CPU.

## PROFIBUS address

For the DP CPU, you **must not set "126"** as a PROFIBUS address.

## See also

User-specific addressing of modules (Page 121)

## 8.5.4 Direct data exchange

### Requirements

STEP 7 V 5.x or higher lets you configure "Direct data exchange" for PROFIBUS nodes. DP CPUs can take part in direct data exchange as senders and receivers.

### Definition

"Direct data exchange" is a special communication relationship between PROFIBUS DP nodes.

Characteristic of direct data exchange are the PROFIBUS DP nodes "Listening" on the bus for data a DP slave returns to its DP master. This mechanism allows "Listening stations" (receivers) direct access to modified input data of remote DP slaves.

### Address Areas

In your STEP 7 configuration of the relevant peripheral input addresses, specify which address area of the receiving node is to receive data requested from the sending node.

The following types of DP-CPU are possible:

- DP slave sending station
- Receiving station, as DP slave or DP master, or as CPU not integrated in a master system.

**Example: Direct data exchange via DP CPUs**

The example in the figure below shows the relationships you can configure for direct data exchange. In the figure all the DP masters and all the DP slaves that are marked as "CPU" are each a DP CPU.

Note that other DP slaves (ET 200M, ET 200pro, ET 200S) can only operate as sending nodes.

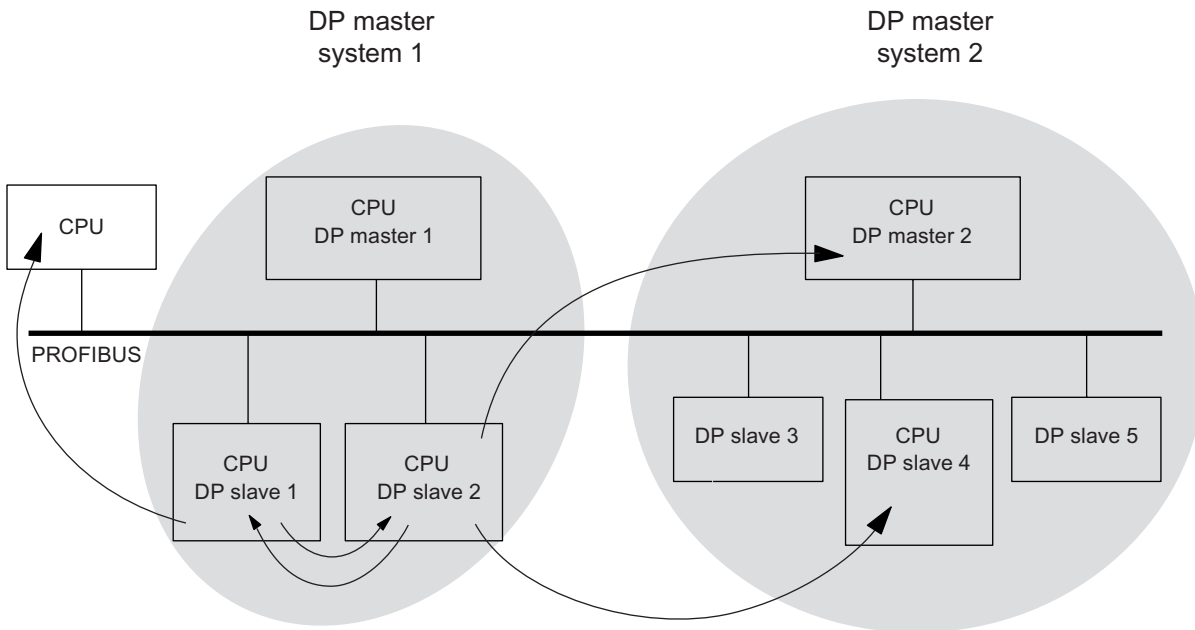

Figure 8-1 Direct data exchange via DP CPUs

## 8.6 Commissioning PROFINET IO

### 8.6.1 Requirements

#### Requirements

PROFINET IO is supported in STEP 7 V 5.3 SP1 or higher. A later version of STEP 7 may be required to support specific CPU functionality. Information about the STEP 7 versions required for specific CPUs is available in the *CPU 31xC and CPU 31x, Technical Data Manual*.

#### PROFINET IO address areas of the CPUs

Table 8- 11 PROFINET IO address areas of the CPUs

Address area	315-2 PN/DP	317-2 PN/DP	319-3 PN/DP
Entire address area of inputs and of outputs	2048 bytes	8192 bytes	8192 bytes
of these in the process image, for inputs and outputs respectively:	max. 2048 bytes	max. 2048 bytes	Max. 4096 bytes
• Default	128 bytes	256 bytes	256 bytes

**Diagnostics addresses** use 1 byte each in the input address space for

- the IO controller, PROFINET interface and ports
- each IO device (header module on slot 0, ports of the PROFINET interface) and all internal modules / submodules of the device which do not contain any user data (power module of ET 200S, or ports of the PROFINET interface, for example).

You can use these addresses, for example, to read module-specific diagnostics data records by calling SFB52. STEP 7 assigns diagnostics addresses in descending order, starting at the highest byte address.

Information about the structure of module-specific diagnostics data records is available in the *From PROFIBUS DP to PROFINET IO Programming Manual*.

## 8.6.2 Configuring and commissioning the PROFINET IO system

### Overview

There are several ways for you to start with commissioning the PROFINET IO interface of the CPU, and then the PROFINET IO system:

- Online via MPI/ DP interface
- Online via switch and PROFINET interface
- Offline, by saving the data to a Micro Memory Card in SIMATIC Manager on your programming device, and then inserting the Micro Memory Card into the CPU

### Commissioning a PROFINET IO system via MPI/DP

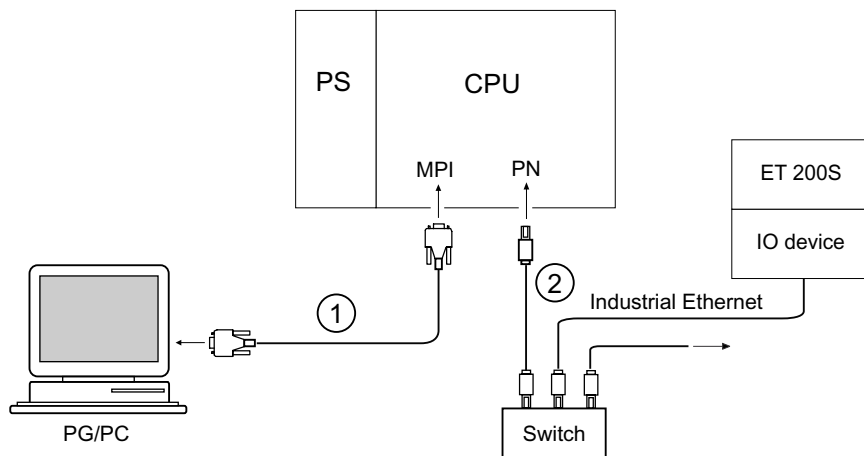

#### Number Meaning

- ① Use the PG cable to connect the PG to the integrated MPI/DP interface of the CPU.
- ② Use the twisted-pair patch cable to interconnect the integrated PROFINET IO interface of the CPU with the Industrial Ethernet (for example, connection to a switch).

### Commissioning a PROFINET IO system directly via PROFINET interface

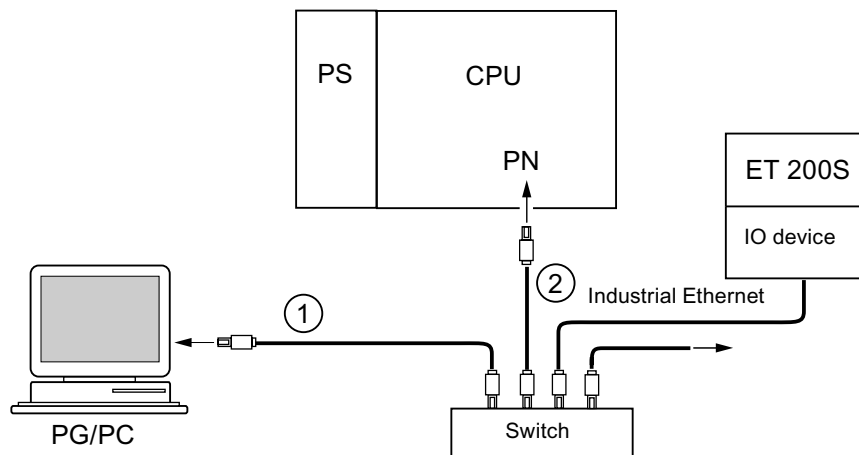

**Number Meaning**

- ① Use a twisted-pair patch cable to connect the PG/PC to a switch
- ② In the same way, connect the switch to the integrated PROFINET interface of your CPU

### Commissioning requirements:

- The CPU is in STOP mode.
- The IO devices are switched on.
- The PROFINET subnet is installed, and the communication partners (for example, PD, IO controller, IO devices) are connected to the PROFINET subnet.

### Configuring the PROFINET IO system

Step	Tasks
<b>Configuring hardware in the STEP 7 SIMATIC Manager</b>	
1	Select <b>File &gt; New...</b> Assign a name to your project and confirm with OK.
2	Select <b>Insert &gt; Station &gt; SIMATIC 300 Station</b> to add an S7-300 station.
3	Double-click "Hardware." <b>Result:</b> HW Config opens.
4	Insert your components by means of drag-and-drop: <ul style="list-style-type: none"> <li>• Mounting rail</li> <li>• Power supply</li> <li>• CPU 31x PN/DP (CPU 317-2 PN/DP, for example)</li> </ul> <b>Result:</b> The "Properties – Ethernet Interface PN-IO" dialog box opens. The properties of the PROFINET X2 interface are shown in the Parameters tab.

Step	Tasks
<b>Assigning the IP address</b>	
5	Click "New" on the "Properties – Ethernet Interface PN-IO" dialog box to create a new subnet. <b>Result:</b> The "Properties – New Industrial Ethernet Subnet" dialog box opens.
6	Assign a name and confirm with "OK." <b>Result:</b> You are back to the "Properties – Ethernet Interface PN-IO" dialog box.
7	Enter the IP address and the subnet mask in the dialog box. This information is available from your network administrator. Note: The worldwide unique MAC address is preset by the manufacturer and cannot be changed.
8	If you setup a connection via router, you must also enter the address of the router. This information is also available from your network administrator.
9	Click "OK" to close the properties dialog box.
<b>Configuring the PROFINET IO system</b>	
10	Insert the IO devices at the PROFINET IO system, for example, an IM 151-3 PN (ET 200S under PROFINET IO), then configure the slots and set their parameters by means of drag-and-drop, based on the physical assembly.
11	Select <b>Edit &gt; Object properties</b> to assign device names and numbers to the IO devices.



Step	Tasks
12	<p>When operating PROFINET IO and PROFINET CBA in parallel, set up the PROFINET IO system properties by</p> <ul style="list-style-type: none"> <li>• activating the "Use this module for PROFINET CBA communication" check box</li> <li>• adapting the "Communication portion (PROFINET IO)" in the "Update time" tab (change the communication portion of PROFINET IO to 87.5 %, for example).</li> </ul>
13	Save your configuration with <b>Station &gt; Save and compile.</b>
<b>Configuration Download</b>	
14	<p>Download the configuration to the CPU. You have three options:</p> <ul style="list-style-type: none"> <li>• Online via MPI/ DP interface (the PG and CPU must be located on the same subnet). When you download the configuration in a system containing several node addresses, select the appropriate MPI or PROFIBUS address of the destination CPU.</li> <li>• Online via switch and PROFINET interface When you download the configuration in a system containing several nodes, select the appropriate IP address of the destination CPU. The "available users" can be displayed in a download dialog box. Select the MAC address of the CPU if you have not assigned it an IP address yet. In the next dialog box, you can assign the configured IP address to the CPU.</li> </ul> <p>The PG must be connected to the subnet. The PG interface must be set to TCP/IP (Auto) mode. Setting in the <b>IE-PG Access</b> tab of the interface properties dialog box: <b>Assign Project-Specific IP Address.</b></p> <ul style="list-style-type: none"> <li>• Offline, by saving the data to a Micro Memory Card in SIMATIC Manager on your programming device, and then inserting the Micro Memory Card into the CPU</li> </ul>

Step	Tasks
<b>Assigning IO device names *</b>	
15	<p><b>Requirements:</b> The programming device must be connected to the subnet. The PG interface must be set to TCP/IP (Auto) mode. Setting in the <b>IE-PG Access</b> tab of the interface properties dialog box: <b>Assign Project-Specific IP Address</b>.</p> <p><b>Procedure:</b> In online mode, select the various IO devices in HW Config, then select <b>PLC &gt; Ethernet &gt; Assign Device Name</b> to assign the corresponding device names.</p> <p><b>Note:</b> The CPU can only assign the IP address automatically, and thus enable its correct communication with the IO device, after you assigned a device name to the latter.</p> <p>If the configuration of the IO devices you downloaded to the CPU actually corresponds with their physical configuration on the subnet, the CPU addresses the IO devices, and the BF LED stops flashing both on the CPU and on the IO device.</p> <p>You can now switch the CPU to RUN, provided there are no other conditions preventing a startup, and the CPU and IO devices exchange data (read inputs, write outputs, for example).</p> <p>* If the functionality "Device replacement without removable medium" is configured in HW Config and the setpoint topology of the PROFINET IO system has been specified using the topology editor, IO devices can be replaced without the user having to assign a device name to the IO device. Requirement: The IO device has been reset to the state of delivery by using "Reset to factory setting" and the actual topology agrees with the setpoint topology.</p>

**Result**

You used STEP 7 to configure the PROFINET interface of your CPU and the and the PROFINET IO system. The CPU can now be reached by other nodes in your Industrial Ethernet subnet.

**Reference**

Detailed information about addressing of the PROFINET IO interface and on the configuration of its properties and ports is available in the:

- *STEP 7 Online Help* and
- *PROFINET System Description System Manual*.

### CPU startup for operation as IO controller

In its startup sequence, and based on the preset configuration, the CPU verifies the actual configuration

- of the local I/O,
- of the distributed I/O on the PROFIBUS DP system, and
- the PROFINET IO system.

The startup of the CPU is determined by the corresponding configuration in the "Startup" tab:

Table 8- 12 CPU startup for operation as IO controller

Preset = Actual configuration	Preset ≠ Actual configuration	
	Startup permitted when target configuration does not match the actual configuration	Startup not permitted when target configuration does not match the actual configuration
CPU goes into RUN.	CPU goes into RUN. After POWER ON, and after the parameter monitoring time has expired, the CPU goes into RUN.  If the BF2/BF3 LED flashes, this means that at least one IO device cannot be addressed. In this case, verify that all IO devices are switched on and correspond with the set configuration. For further information, read the diagnostics buffer in STEP 7.	CPU startup fails

### Detecting interruptions in the data transfer to the IO device

The following table shows, how the CPU 31x PN/DP recognizes interruptions of the data transfer:

Table 8- 13 Even recognition of the CPU 31x PN/DP as IO controller

Event	What happens in the IO controller?	
	CPU in RUN	CPU in STOP
Bus interruption (short circuit, connector removed)	<ul style="list-style-type: none"> <li>• Call of OB86 with the message <b>Station failure</b> (coming event; diagnostics address of the IO device)</li> <li>• With I/O access: call of OB 122 (I/O access error)</li> </ul>	<ul style="list-style-type: none"> <li>• The event is written to the diagnostics buffer</li> </ul>

**Tip:**

Always program OB86 when you commission the CPU. This allows you to detect and analyze interruptions in the data transfer.

### Status/control, programming via PROFINET

As an alternative to the MPI /DP interface, you can program the CPU or execute the PG's status and control functions via the PROFINET interface..

If you have not commissioned the PROFINET interface of the CPU yet, you can connect to the CPU using its MAC address (see also **Configuring the PROFINET IO System** in the table above).

To do so, use HW Config to download your project to the CPU. Address the CPU using its MAC address. The CPU is also assigned the configured IP address after you downloaded the configuration. With that you can then use all programming device functions, such as download program, status/control etc., on the interface.

# Maintenance

## 9.1 Overview

S7-300 is a maintenance-free automation system.

Thus, maintenance is considered

- Backing up of the operating system on a SIMATIC Micro Memory Card
- Updating of the operating system from a SIMATIC Micro Memory Card
- Updating of the firmware online
- Backing up of project data on a SIMATIC Micro Memory Card
- Replacement of modules
- Replacement of fuses in digital output modules

## 9.2 Backing up firmware on a SIMATIC Micro Memory Card

### Situations which require backup of the firmware

It is advisable in certain situation to backup your CPU firmware:

You may want to replace the CPU in your system with a CPU out of storage. In this case you should make sure that the firmware of the shelf CPU and of the system firmware are identical.

It is also advisable to create an emergency backup copy of the firmware.

## 9.3 Updating the firmware

### 9.3.1 Backing up firmware on a SIMATIC Micro Memory Card

#### On which CPUs can you backup the firmware?

You can generate a backup copy of the the firmware as of the following CPU versions:

CPU	Order No.	Firmware as of	Required Micro Memory Card ≥ in MB
312	as of 6ES7312-1AD10-0AB0	V2.0.0	2
	as of 6ES7312-1AE13-0AB0	V2.0.12	
314	as of 6ES7314-1AF10-0AB0	V2.0.0	2
	6ES7314-1AG13-0AB0 or later	V2.0.12	
315-2 DP	as of 6ES7315-2AG10-0AB0	V2.0.0	4
312C	as of 6ES7312-5BD00-0AB0	V1.0.0	2
	as of 6ES7312-5BE03-0AB0	V2.0.12	
313C	as of 6ES7313-5BE00-0AB0	V1.0.0	2
	as of 6ES7313-5BF03-0AB0	V2.0.12	
313C-2 DP	as of 6ES7313-6CE00-0AB0	V1.0.0	4
	as of 6ES7313-6CF03-0AB0	V2.0.12	
313C-2 PtP	as of 6ES7313-6BE00-0AB0	V1.0.0	2
	as of 6ES7313-6BF03-0AB0	V2.0.12	
314C-2 DP	as of 6ES7314-6CF00-0AB0	V1.0.0	4
	as of 6ES7314-6CG03-0AB0	V2.0.12	
314C-2 PtP	as of 6ES7314-6BF00-0AB0	V1.0.0	2
	as of 6ES7314-6BG03-0AB0	V2.0.12	
315-2 PN/DP	as of 6ES7315-2EG10-0AB0	V2.3.0	4
	as of 6ES7315-2EH13-0AB0	V2.3.4	
317-2 DP	as of 6ES7317-2AJ10-0AB0	V2.1.0	4
317-2 PN/DP	as of 6ES7317-2EJ10-0AB0	V2.2.0	4
	as of 6ES7317-2EK13-0AB0	V2.3.4	
319-3 PN/DP	as of 6ES7318-3EL00-0AB0	V2.4.0	8

## Backing up the firmware of your CPU to the SIMATIC Micro Memory Card

Table 9- 1 Backing up the firmware to the SIMATIC Micro Memory Card

Step	Action required:	This happens in the CPU:
1.	Insert the new SIMATIC Micro Memory Card into the CPU.	The CPU requests memory reset
2.	Turn the mode selector switch to MRES position and hold it there.	-
3.	POWER OFF / POWER ON. Hold the mode selector switch in MRES position until ...	... the STOP, RUN and FRCE LEDs start flashing.
4.	Mode selector switch to STOP.	-
5.	Mode selector switch briefly to MRES position, then let it return to STOP.	<ul style="list-style-type: none"> <li>• The CPU starts to backup the operating system on the SIMATIC MMC.</li> <li>• All LEDs are lit during the backup operation.</li> <li>• The STOP LED flashes when the backup is complete to indicate that the CPU requires a memory reset.</li> </ul>
6.	Remove the SIMATIC Micro Memory Card.	-

### 9.3.2 Firmware update using a Micro Memory Card

#### In which situations should I update the firmware?

After (compatible) function expansions, or after an enhancement of operating system performance, the firmware of the CPU should be upgraded (updated) to the latest version.

---

#### Note

##### Prioritized startup

At a prioritized startup a firmware update using the Micro Memory Card is not possible. A firmware update using the LAN network is possible.

---

#### Where do I get the latest version of the firmware?

You can order the latest firmware (as \*.UPD files) from your Siemens partner, or download it from the Siemens Internet homepage:

<http://www.siemens.com/automation/service&support>

**Firmware update using a SIMATIC Micro Memory Card**

Table 9- 2 Firmware update using a SIMATIC Micro Memory Card

Step	Action required:	This happens in the CPU:
1.	<b>Recommendation</b> Before you update the CPU firmware, create a backup copy of the "old" firmware on an empty SIMATIC Micro Memory Card. If problems occur during the update, you can reload your old firmware from the SIMATIC Micro Memory Card.	
2.	Transfer the update files to a blank SIMATIC Micro Memory Card using STEP 7 and your programming device.	-
3.	Switch off CPU power and insert a SIMATIC Micro Memory Card containing the firmware update.	-
4.	Switch on power.	<ul style="list-style-type: none"> <li>• The CPU automatically detects the SIMATIC Micro Memory Card with the firmware update and runs the update.</li> <li>• All LEDs are lit during firmware update.</li> <li>• The STOP LED flashes when the FW update is completed, and indicates that the CPU requires a memory reset.</li> </ul>
5.	Switch off CPU power and remove a SIMATIC Micro Memory Card containing the firmware update.	-

**Result**

You updated the CPU with a new firmware version.

The address and baud rate of the 1st interface are retentive. All the other parameters have been reset by the firmware update.



### 9.3.3 Updating the firmware online (via networks)

#### On which CPUs can you update the firmware online?

You can carry out a firmware update online at all the CPUs V 2.2 and higher.

Information about the firmware update online using MPI or DP networks for older modules is available on the Service&Support pages (<http://www.siemens.com/automation/service>).

#### Requirements

- An online firmware update is possible in STEP 7 V 5.3 or higher.
- To update the firmware, you require the \*.UPD files which contain the current firmware version.
- The files (\*.UPD) containing the current firmware version must be available in the file system on your PG/PC. A folder may contain only the files of one firmware version.
- The CPU can be accessed online.

#### Performing a firmware update

1. Run STEP 7 and change to HW Config.
2. Open the station containing the CPU you want to update.
3. Select the CPU.
4. Select the menu command **PLC > Update Firmware**. The menu command can only be executed if the selected CPU supports the "Update Firmware" function.
5. The **Update firmware** dialog box opens. Click **Browse** to select the path to the firmware update files (\*.UPD)
6. After you selected a file, the information in the lower fields of the **Update Firmware** dialog box shows you the firmware file and version for the corresponding modules.
7. Click the **Run** button. STEP 7 verifies that the selected file can be interpreted by the module, and then downloads the file to the CPU. If this requires changing the operating state of the CPU, you will be asked to perform these tasks in the relevant dialog boxes. The CPU then automatically updates the firmware.
8. In STEP 7 (reading the CPU diagnostics buffer), verify that the CPU can start with the new firmware.

#### Result

You have updated the CPU online with a new firmware version.

The address and baud rate of the 1st interface are retentive. All the other parameters have been reset by the firmware update.

## 9.4 Backup of project data to a Micro Memory Card

### Function principles

Using the **Save project to Micro Memory Card** and **Retrieve project from Micro Memory Card** functions, you can save all project data to a SIMATIC Micro Memory Card, and retrieve these at a later time. The SIMATIC Micro Memory Card can be located in a CPU or in the Micro Memory Card programming adapter of a PG or PC.

Project data is compressed before it is saved to a SIMATIC Micro Memory Card, and uncompressed on retrieval.

---

#### Note

In addition to project data, you may also have to save your user data to the SIMATIC MMC. Always select a SIMATIC Micro Memory Card with sufficient memory capacity.

A message warns you of insufficient memory capacity on your SIMATIC Micro Memory Card.

---

The volume of project data to be saved corresponds with the size of the project's archive file.

---

#### Note

For technical reasons, you can only transfer the entire contents (user program and project data) using the **Save project to Micro Memory Card** action.

---

## Handling the functions

How you use the **Save project to memory card / Retrieve project from memory card** functions depends on the location of the SIMATIC micro memory card:

- When the SIMATIC MMC is inserted in the MMC slot, select a project level (for example, CPU, programs, sources or blocks) which is uniquely assigned to the CPU from the project window in SIMATIC Manager. Select the **PLC > Save project to Memory Card** or **PLC > Retrieve project from Memory Card** menu command. The program now writes all configuration data to the SIMATIC Micro Memory Card, or retrieves these data from the card.
- If project data are not available on the currently used programming device (PG/PC) you can select the source CPU from the "Available nodes" window. Select **PLC > Show available nodes** command to open the "Available nodes" window. Select the connection/CPU that contains your project data on SIMATIC Micro Memory Card. Now select menu command **Retrieve project from Memory Card**.
- If the SIMATIC MMC is located in the MMC programming unit of a PG or PC, open the "S7 memory card window" using the **File > S7 Memory Card > Open command**. Select the **PLC > Save project to Memory Card** or **PLC > Retrieve project from Memory Card** menu command. to open a dialog in which you can select the source or target project.

---

### Note

Project data can generate high data traffic. Especially in RUN mode with read/write access to the CPU, this can lead to waiting periods of several minutes.

---

## Sample application

When you assign more than one member of your service and maintenance department to perform maintenance tasks on a SIMATIC PLC, it may prove difficult to provide quick access to current configuration data to each staff member.

However, CPU configuration data available locally on any CPU that is to be serviced can be accessed by any member of the service department. They can edit these data and then release the updated version to all other personnel.

## 9.5 Resetting to the Delivery State

### Delivery state of the CPU

Default values set at the CPU properties:

Table 9- 3 Properties of the CPU in the delivery state

Properties	Value
MPI address	2
MPI baud rate	187.5 Kbps
Retentive bit memories, timers and counters	All retentive bit memories, timers and counters are deleted
Retentive range set for bit memories, timers and counters	Default settings (16 memory bytes, no timers and 8 counters)
Contents of the diagnostics buffer	deleted
IP address	none
Operating hours counter	0
Time	1.1.94 00:00:00

### Procedure

Proceed as follows in order to reset a CPU to the delivery state via the mode selector switch:

1. Switch off the supply voltage.
2. Remove the SIMATIC Micro Memory Card from the CPU.
3. Hold the mode selector switch in the MRES setting and switch the supply voltage on again.
4. Wait until LED lamp image 1 from the subsequent overview is displayed.
5. Release the mode selector switch, set it back to MRES within 3 seconds and hold it in this position.
6. Wait until LED lamp image 2 from the next overview is displayed.  
This lamp image lights up for approximately five seconds, that is for the duration of RESET. During this period you can abort the resetting procedure by releasing the mode selector switch.
7. Wait until LED lamp image 3 from the subsequent overview is displayed and release the mode selector switch again.

The CPU is now reset to the delivery state. It starts without buffering (all LEDs are lit) and changes to the STOP mode

### Lamp images while the CPU is being reset

While you are resetting the CPU to the delivery state, the LEDs light up consecutively in the following lamp images:

Table 9- 4 Lamp images

LED	Color	Lamp image 1	Lamp image 2	Lamp image 3
STOP	Yellow	○	□	□
RUN	Green	○	□	□
FRCE	Yellow	○	□	□
5 VDC	Green	△	△	△
SF	Red	□	○	△
BFX	Red	□	□	□

△ = LED lit

□ = LED dark

○ = LED flashes at 0.5 Hz

## 9.6 Module installation / removal

### Installation and wiring rules

The table below shows you points to follow when wiring, installing or removing S7-300 modules.

Rules governing	... Power supply	... CPU	... SM/FM/CP
Blade width of the screwdriver	3.5 mm (cylindrical design)		
Tightening torque <ul style="list-style-type: none"> <li>• Fixing modules to the mounting rail</li> <li>• Connecting cables</li> </ul>	from 0.8 N/m to 1.1 N/m		from 0.8 N/m to 1.1 N/m
	from 0.5 N/m to 0.8 N/m		–
POWER OFF when replacing the ...	Yes		Yes
S7-300 operating mode when replacing ...	–		STOP
Load voltage OFF when replacing the ...	Yes		Yes

### Initial situation

The module you want to replace is still mounted and wired. You want to install the same type of module.

 <b>WARNING</b>
<p>Disturbances can corrupt data if you insert or remove S7-300 modules while data are being transferred via the integrated interface of your CPU. You should never replace any modules of the S7-300 while data traffic is active at an integrated interface. If you are not certain whether or not data transfer is active on the interface, unplug the connector at the interface before you replace the module.</p>

## Removing the module (SM/FM/CP)

To remove the module:

Step	20-pin front connector	40-pin front connector
1.	Switch the CPU to STOP.	
2.	Switch off the load voltage to the module.	
3.	Remove the labeling strip from the module.	
4.	Open the front door.	
5.	Unlock the front connector and remove it. To do so, press down the unlocking mechanism with one hand and pull out the front connector at the grips using the other hand.	Remove the fixing screw from the middle of the front connector. Pull the front connector out, holding it at the grips.
6.	Undo the module fixing screw(s).	
7.	Swing the module out.	

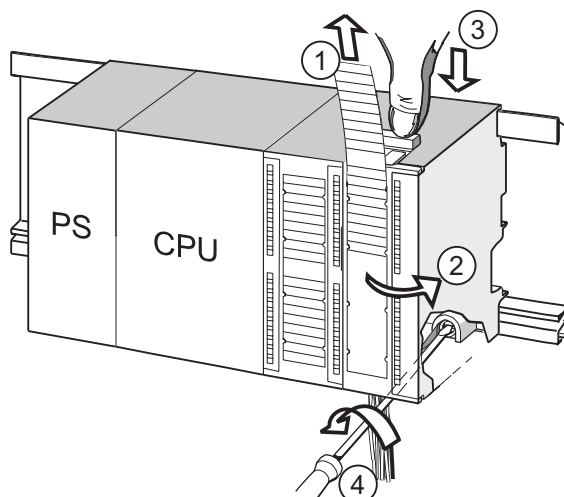

### Number Identifier

- ① Remove labeling strips.
- ② Open module.
- ③ Press unlocking mechanism/loosen mounting screw, and pull out front connector.
- ④ Remove mounting screw of module and swing module out.

### Removing the front connector coding from the module

Before you start installing the new module, remove the upper part of the front connector coding pin from this module.

Reason: This part is already inserted in the wired front connector.

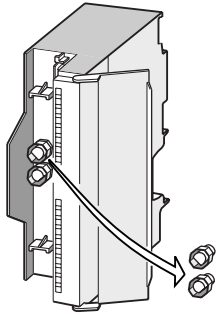

### Installing a new module

To install the new module:

1. Hang in a new module of same type.
2. Swivel the module down into place.
3. Screw-tighten the module.
4. Slide the labeling strips into the module.

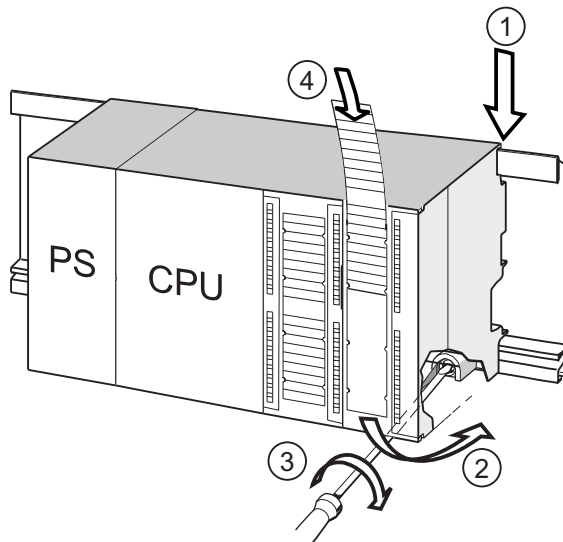

Number	Identifier
①	Hang module onto rail.
②	Swivel module downward.
③	Screw-tighten the module
④	Insert labeling strips.



### Removing the front connector coding from the front connector

You may take a "used" front connector to wire another module by removing its coding mechanism:

Simply use a screwdriver to push out the front connector coding.

This upper part of the coding key must then be plugged back into the old module.

### Putting a new module into service

Proceed as follows to put the new module into service:

1. Open the front door.
2. Reinstall the front connector.
3. Close the front panel.
4. Switch the load voltage back on.
5. Reset the CPU to RUN mode.

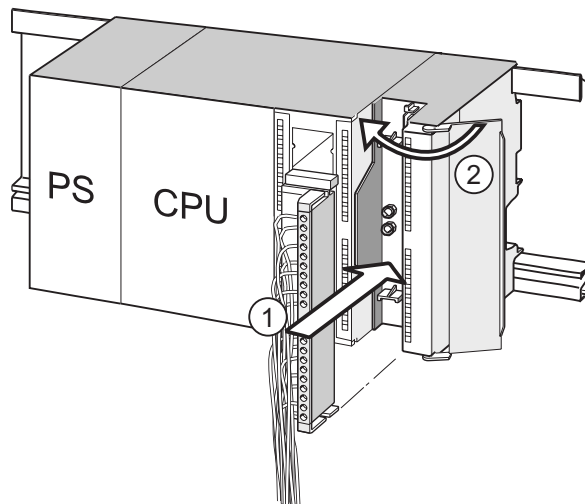

**Number Identifier**

- ① Move the front connector into operating position
- ② Close front panel.

### Reaction of the S7-300 after module replacement

After a module replacement, the CPU switches to run mode, provided no error has occurred. If the CPU stays in STOP you can view the cause of error in STEP 7 (see the *Programming with STEP 7* User manual).

## 9.7 Digital output module AC 120/230 V: Changing fuses

### Fuses for digital outputs

The digital outputs of the following digital output modules are short-circuit protected by fusing of the channel groups:

- Digit output module SM 322; DO 16 × A 120 V
- Digit output module SM 322; DO 8 × 120/230 VAC

### System check

Eliminate the causes of fuse tripping.

### Replacement fuses

If replacement is required, you can use the following fuses:

- 8 A, 250 V fuse
  - Wickmann 19 194-8 A
  - Schurter SP001.013
  - Littlefuse 217.008
- Fuse holder
  - Wickmann 19 653

 <b>WARNING</b>
Improper handling of digital output modules could result in injury or damage to property. There are dangerous voltages > 25 VAC or > 60 VDC beneath the covers to the right of the module. Before you open these covers, make sure that you have either unplugged the front connector from the module or isolated the module from power.

 <b>WARNING</b>
Improper handling of front connectors could result in injury or damage to property. When you remove the front connector while the system is in RUN, beware of dangerous live voltage > 25 VAC or > 60 VDC across the pins. If the front connector is wired to such voltages, hot swapping of modules must always be carried out by skilled or instructed electrical staff, in order to avoid unintentional contact to the module pins.

### Location of fuses in the digital module 120/230 VAC

Digital output modules are equipped with 1 fuse per channel group. The fuses are located at the left side of the digital output module. The following figure shows you where to find the fuses on the digital output modules.

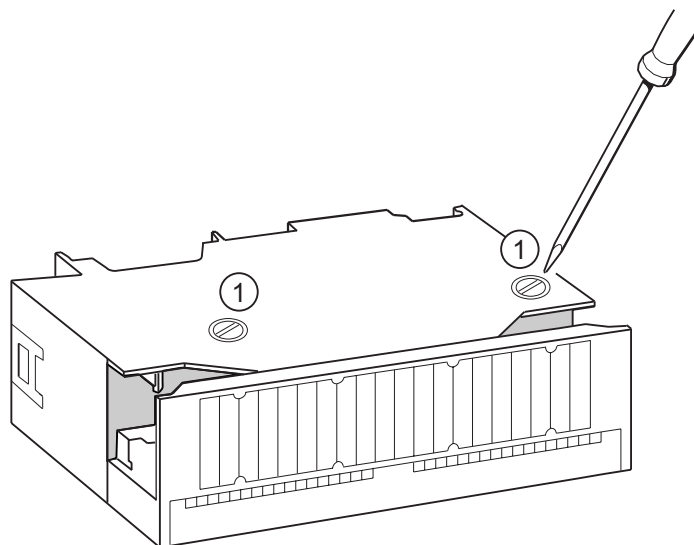

### Replacing fuses

The fuses are located at the left side of the module. Replace the fuses as follows:

1. Switch the CPU to STOP.
2. Switch off the load voltage of the digital output module.
3. Remove the front connector from the digital output module.
4. Loosen the fixing screw of the digital output module.
5. Swing out the digital output module.
6. Remove the fuse holder from the digital output module ①.
7. Replace the fuse.
8. Screw the fuse holder back into the digital output module.
9. Reinstall the digital output module.



# Debugging functions, diagnostics and troubleshooting

# 10

## 10.1 Overview

This chapter helps you to get acquainted with tools you can use to carry out the following tasks:

- Hardware/software error diagnostics.
- Elimination of hardware/software errors.
- Testing the hardware/software – for example, during commissioning.

---

### Note

It would go beyond the scope of this manual to provide detailed descriptions of all the tools you can use for diagnostics, testing and troubleshooting functions. Further notes are found in the relevant hardware/software manuals.

---

## 10.2 Identification and maintenance data of the CPU

### Definition and properties

Identification and maintenance data (I&M) is information that is stored in a module for the purpose of providing you with support when

- checking the system configuration
- locating modified plant hardware
- troubleshooting a plant

Identification data (I data) is information about the module (some of which may be printed on the module housing) such as the order and serial number. I data represent fixed information from the manufacturer about the module and are read-only.

Maintenance data (M data) represent system-specific information such as the installation location. M data is created during configuration and written to the module.

I&M data can be used to identify modules uniquely on the network.

### Reading and writing I&M data with STEP 7

#### Read

- STEP 7 returns I&M data in "Module status" ("General" and Identification" tab) and in "Available nodes" (detail view). See the STEP 7 Online Help.
- You can read I&M data by calling SFC51 in the user program. Declare the SSL parts list number and index at the input parameters of SFC51 (see the table below).
- CPUs which support reading of I&M data on the "Start page" and "Identification" page using the web server:

CPU	Firmware
CPU 315-2 PN/DP	as of V 2.5
CPU 317-2 PN/DP	as of V 2.5
CPU 319-3 PN/DP	as of V 2.5

#### Write

You always required STEP 7 HW Config to write M-data of the modules.

Data you can enter in the course of configuration , for example:

- Name of the AS (station name)  
The station name is assigned in SIMATIC Manager when you create the station. The program generates a default station, for example, "SIMATIC 300(1)". You can always change this name.
- Data you can enter in STEP 7 HW Config, "CPU properties", "General" tab:
  - Name of the module  
HW Config assigns a default name
  - Plant ID of the module  
No default setting
  - Location identifier (LID) of a module  
No default setting

### Reading the I&M data in the user program

In order to read I&M data of the CPU in the user program, define the SSL ID and index and read the corresponding SSL by calling SFC51. The table below shows the SSL IDs and associated indexes.

## SSL partial lists with I&M data

The I&M data are available in the SSL partial lists at the defined indexes.

Table 10- 1 SSL partial lists with I&M data

SSL-ID W#16#...	Index W#16#...	Meaning
<b>Module identification</b>		
0111		an identification data record
	0001	Identification of the module The module order number and release version are stored here.
	0006	Identification of the basic software Returns information about the SW version of the module. (These identification data are identical to index 0001, as a basic software is not available for S7-300 CPUs.)
	0007	Identification of the basic firmware Indicates the firmware version of the module.
<b>Component identification</b>		
011C		Component identification
	0001	Name of the AS Returns the name of the AS (station name).
	0002	Name of the module Returns the name of the module.
	0003	Plant ID of the module Returns a unique identifier for the module.
	000B	Location identifier (LID) of a module Returns the installation location of the module.

## Reference

For detailed information about the structure and content of the SSLs, refer to the *System Software for S7-300/400, System and Standard Functions Manual* and to the *STEP 7 Online Help*.

## I&M data of connected I/O

Information about the I&M data of I/O connected to the CPU is available in the manuals of the corresponding I/O modules.

## 10.3 Overview: Test functions

### Determining addressed nodes with "Node flashing test" (for CPUs >= V2.2.0)

To identify the addressed node, select PLC > Diagnostics/Setting > Node/Flashing Test in STEP 7.

A dialog appears in which you can set the flashing time and start the flashing test. The directly connected node can be identified by a flashing FORCE LED. The flashing test cannot be performed if the FORCING function is active.

### Debugging functions of the software: Monitoring and controlling tags, stepping mode

STEP 7 offers you the following testing functions you can also use for diagnostics:

- Monitoring and controlling tags

Can be used for PG/PC monitoring of specific CPU or user program tags. You can also assign constant values to the tags.

- Testing with program status

You can test your program by viewing the program status of each function (result of logical links, status bit) or the data of specific registers in real-time mode.

For example, if you have selected the programming language LAD in STEP 7 for your presentation, the color of the symbol will indicate a closed switch or an active circuit.

---

#### Note

The STEP 7 testing function with program status extends the CPU cycle time! In STEP 7 you can customize the maximum permitted increase in cycle time (not for CPU 3182 DP). In this case, set process mode for the CPU parameters in STEP 7.

---

- stepping mode

When testing in single-step mode, you can process your program instructions in sequence (= single-step) and set break points. This is only possible in testing mode and not in process mode.



## Debugging functions of the software: Forcing tags

The Force function can be used to assign the tags of a user program or CPU (also: inputs and outputs) constant values which can not be overwritten by the user program.

For example, you can use it to jumper sensors or switch outputs permanently, irrespective of the user program.

**! DANGER**

This could result in severe injury or even death, and damage to property. Incorrect use of the Force function could result in death or severe injury, and damage to machinery or even the entire plant. Always follow the safety instructions in the *STEP 7 manuals*.

**! DANGER**

**Forcing with S7-300 CPUs**

The force values in the process image of the **inputs** can be overwritten by write commands (such as T IB x, = I x.y, Copy with SFC, etc.) and by read I/O commands (such as L PIW x) in the user program, or by write PG/OP functions! Outputs initialized with forced values only return the forced value if not accessed by the user program via peripheral write instructions (TPQB x, for example) or by PG/OP write functions!

Always ensure that forced values in the I/O process image cannot be overwritten by the user program or PG/OP functions!

S7-300-CPU forcing corresponds to "cyclical controlling"

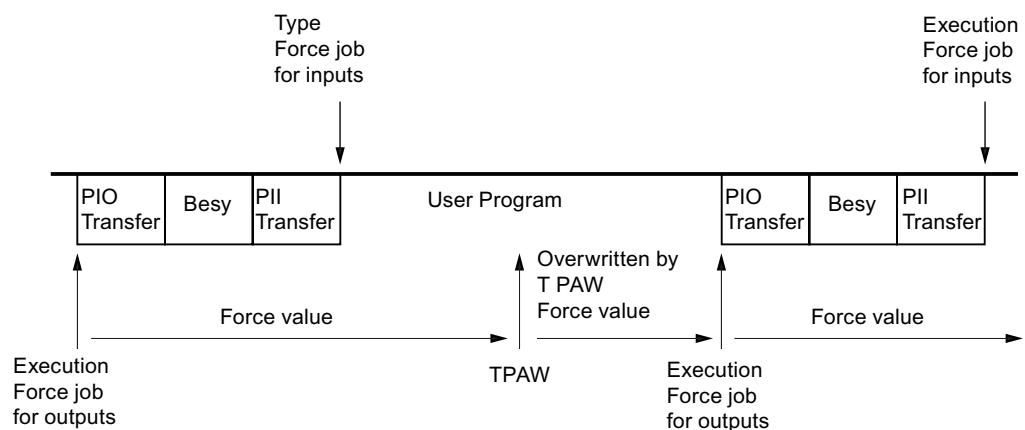

Besy Operating system editing

Figure 10-1 Principle of forcing in S7-300 CPUs

## Differences between forcing and controlling tags

Table 10- 2 Differences between forcing and controlling tags

Characteristics/function	Forcing	Controlling tags
Memory bit (M)	-	Yes
Timers and counters (T, C)	-	Yes
Data blocks (DB)	-	Yes
Inputs and outputs (I, O)	Yes	Yes
Peripheral inputs (PI)	-	-
Peripheral outputs (PO)	-	Yes
User program can overwrite modify/force values	Yes	Yes
Maximum number of force values	10	-
Power off retentive	Yes	No

### Reference

Details on debugging functions of the software are available in the *STEP 7 Online Help* and in the *Programming with STEP 7 Manual*.

## 10.4 Overview: Diagnostics

### Introduction

System errors can occur especially in the commissioning phase. Tracking these errors might be a time-consuming effort, since they can occur both on the hardware and software side. Here, the multitude of testing functions ensures commissioning without problems.

---

### Note

Errors during **operation** are almost always a result of faults or damage to the hardware.

---

### Type of error

Errors the S7 CPUs can recognize and to which you can react with the help of organization blocks (OBs) can be split into the following categories:

- Synchronous error: Errors you can relate to a specific point in the user program (error when accessing a peripheral module, for example).
- Asynchronous error: Errors you can **not** relate to a specific point in the user program (cycle time exceeded, module error, for example).

## Troubleshooting

Programming with foresight and, above all, knowledge and proper handling of diagnostic tools puts you into an advantageous position in error situations:

- You can reduce the effects of errors.
- It makes it easier for you to locate errors (by programming error OBs, for example).
- You can limit downtimes.

## Diagnostics with LED display

SIMATIC S7 hardware offers diagnostics with LEDs.

These LEDs are implemented in three colors:

LED color	State of CPU
Green	Regular operation. Example: Power is on.
Yellow	Non-regular operating status. Example: Forcing is active.
Red	Fault. Example: Bus error
LED flashing	Special event Example: CPU memory reset

Two LEDs are used for Ethernet:

LED designation	Color	State	Meaning
LINK	Green	Off	No other device is connected with the integrated PROFINET interface of the CPU.
		On	Another device (in most cases a switch) is connected to the integrated PROFINET interface of the CPU, and the physical connection is in place.
RX/TX	Yellow	Off	No activity: No data are transferred via the integrated PROFINET interface of the CPU.
		On	Activity: Data are transferred via the integrated PROFINET interface of the CPU. Note: The LED flickers when small data volumes are transferred.

## Reference

Notes on diagnostics of I/O modules capable of diagnostics are found in the relevant Manual.

### Diagnostic buffer

If an error occurs, the CPU writes the cause of error to the diagnostic buffer. In STEP 7 you use the programming device to read the diagnostic buffer. This location holds error information in plain text.

Other modules capable of diagnostics can be equipped with their own diagnostic buffer. In STEP 7 (HW Config -> Diagnosing hardware) you can use the programming device to read this buffer.

Diagnosable modules without diagnostic buffer write their error information to the CPU's diagnostic buffer.

When an error or an interrupt event occurs, (e.g. time-of-day interrupt), the CPU switches to STOP mode, or you can react in the user program via error/interrupt OBs. For a diagnostics interrupt you would call OB82.

### Diagnostics of field devices on PROFINET

Further information:

- *PROFINET System Description* System Manual.
- *From PROFIBUS DP to PROFINET IO* Programming Manual

The topics in the next chapters are focused on the diagnostics of local or distributed modules on PROFIBUS.

### Diagnostics with system functions

If the following CPUs are used, we recommend that you use the more user-friendly SFB 54 RALRM (called in diagnostic OB82) to evaluate the diagnostics from centralized or distributed modules or DP slaves:

CPU	As of firmware version
31xC, 312, 314, 315-2 DP	V 2.0.0
315-2 PN/DP	V 2.3.0
317-2 DP	V 2.1.0
317-2 PN/DP	V 2.2.0
319-3 PN/DP	V 2.4.0

Further options for diagnostics with system functions are listed below:

- Using **SFC 51** "RDSYSST" to read an SSL partial list or an extract thereof.
- Reading the diagnostic data (slave diagnostics) of a DP slave, using **SFC 13** "DPNRM\_DG"

Every DP slave provides slave diagnostic data according to EN 50 170 Volume 2, PROFIBUS. You can use SFC 13 "DPNRM\_DG" to read these diagnostic data. Error information is stored in hex code. Refer to the relevant module manual for information on the meaning of the read code.

For example, the entry of the value 50H (= dual 0101 0000) in byte 7 of the slave diagnostics for the distributed I/O module ET 200B indicates a faulty fuse or missing load voltage in channel group 2 and 3.

- Reading data records by calling **SFC52 "RDREC"**

You can call SFC52 "RDREC" (read record) to read a specific data record from the addressed module. Data records 0 and 1 are especially suitable for reading diagnostic information from a diagnosable module.

Data record 0 contains 4 bytes of diagnostic data describing the current state of a signal module. Data record 1 contains the 4 bytes of diagnostic data also stored in data record 0, plus module-specific diagnostic data.

- Reading out the start information of the current OB, using the **SFC 6 "RD\_SINFO"**

Error information is also found in the start information of the relevant error OB.

You can use SFC 6 "RD\_SINFO" (read start information) to read the start information of the OB that was last called and not yet processed completely, and of the start-up OB that was last called.

- Triggering detection of the bus topology in a DP master system with the **SFC103 "DP\_TOPOL"**

The diagnostics repeater improves the ability to locate faulty modules or an interruption on the DP cable when failures occur in ongoing operation. It operates in slave mode and is capable of logging faults based on the determination of the DP segment topology.

You can use SFC103 "DP\_TOPOL" to trigger the identification of the bus topology of a DP master system by the diagnostic repeater. The SFCs 103 are described in the corresponding *STEP 7 Online Help* and in the *System Software S7-300/400, System and Standard Functions Reference Manual*. The diagnostic repeater is described in the manual *Diagnostic Repeater for PROFIBUS DP*.

## 10.5 Diagnostics functions available in STEP 7

### Diagnostics using the "Diagnosing Hardware" function

Locate the cause of a module error by viewing the online information on the module. You can locate the cause of an error in the user program cycle with the help of the diagnostic buffer and of the stack content. You can also check whether a user program will run on a specific CPU.

Hardware diagnostics give you an overview of the PLC status. In an overview representation, a symbol can display the error status of every module. A double-click on the faulty module opens detailed error information. The scope of this information depends on the specific module. You can view the following information:

- Display of general information on the module (e.g. order No., version, designation) and module status (e.g. error).
- Indication of module errors (channel error, for example) at local I/O and PROFIBUS DP slaves or PROFINET IO devices.
- Display of messages from the diagnostic buffer.
- Maintenance information: Maintenance demanded and maintenance required
- In addition, diagnostics data about the PROFINET interface are presented.

For CPUs you can also view the following module status information:

- Cause of an error in the user program cycle.
- Indication of the cycle time (longest, shortest and last cycle).
- Options and utilization of MPI communication.
- Indication of performance data (number of possible I/O, memory bits, counters, timers and blocks).
- Diagnostics (network connection, communications diagnostics and statistics, for example) of the PROFINET interface and of its ports

For details on diagnostic functions in STEP 7 and on procedures, refer to the *Programming with STEP 7 Manual* and to the *HW Config Online Help*.

## 10.6 Network infrastructure diagnostics (SNMP)

### Availability

As an open standard, you can use any SNMP-based systems or software solutions for diagnostics in PROFINET.

### Network diagnostics

SNMP (Simple Network Management Protocol) makes use of the wireless UDP transport protocol. It consists of two network components, similar to the client/server model. The SNMP manager monitors the network nodes and the SNMP agents collect the various network-specific information in the individual network nodes and store them in a structured form in the **MIB** (Management Information Base). This information allows a network management system to run detailed network diagnostics.

### Detecting the network topology

LLDP (Link Layer Discovery Protocol) is a protocol that is used to detect the closest neighbors. It enables a device to send information about itself and to save information received from neighboring devices in the LLDP MIB. This information can be looked up via the SNMP. This information allows a network management system to determine the network topology.

### Integration into STEP 7

Configuration of the OPC server is integrated into the STEP 7 Hardware Configuration. Stations from the STEP 7 project that are already configured can be transferred directly. As an alternative to STEP 7, the configuration can also be run with the NCM PC (included on the SIMATIC NET CD) or can be determined automatically and transferred to the project configuration.

A STEP 7 connection is not required for network management with the SNMP protocol.

### Use of SNMP in the SIMATIC NET environment

SNMP-capable devices from the SIMATIC NET family can be monitored and operated via a conventional standard Internet browser. The management system known as web-based management offers a range of device-specific information (network statistics, status of redundant supply, for example).

### **Diagnostics with the SIMATIC NET SNMP OPC server**

The SNMP OPC server software provides the diagnostics and parameter assignment for all SNMP devices. The OPC server uses the SNMP protocol to exchange data with these devices.

All information can be integrated into OPC-compatible systems, into WinCC HMI system for example. This enables process and network diagnostics to be combined in the HMI system.

### **Uses of SNMP**

SNMP can be used as follows:

- By users, to integrate network diagnostics into a central HMI/SCADA system using the SNMP OPC server.
- By the IT administrators of machine and plant owners to monitor their Industrial Ethernet network using standard network management systems.
- By the IT administrators, primarily to monitor the office network, and in many cases also the automation network, using standard network management systems (for example, HP Openview).

### **Further Information**

Information relating to SNMP in the network management standardization group can be found at <http://www.profinet.com>.

Further details about SNMP can be found at <http://www.snmp.org>.

Further information about the SNMP OPC server can be found at <http://www.siemens.com/snmp-opc-server>.



## 10.7 Diagnostics using status and error LEDs

### 10.7.1 Introduction

Diagnostics with LEDs is an initial tool for error localization. Usually, you evaluate the diagnostic buffer for further error localization.

The buffer contains plain text information on the error that has occurred. For example, you will find the number of the appropriate error OB here. You can prevent the CPU from going into STOP mode by generating this OB and downloading it to the CPU.

### 10.7.2 Status and error displays of all CPUs

Table 10-3 Status and error displays

LED					Meaning
SF	5 VDC	FRCE	RUN	STOP	
Off	Off	Off	Off	Off	CPU power supply missing. Remedy: Check whether the power supply module is connected to mains and switched on.
Off	On	X (see the description)	Off	On	The CPU is in STOP mode. Remedy: Start the CPU.
On	On	X	Off	On	The CPU is in STOP mode as a result of error. Remedy: refer to the tables below, evaluation of the SF LED
X	On	X	Off	Flashes (0.5 Hz)	The CPU requests memory reset.
X	On	X	Off	Flashes (2 Hz)	The CPU executes memory reset.
X	On	X	Flashes (2 Hz)	On	The CPU is in startup mode.
X	On	X	Flashes (0.5 Hz)	On	The CPU was halted by a programmed break point. For details refer to the <i>Programming with STEP 7 Manual</i> .
On	On	X	X	X	Hardware or software error Remedy: refer to the tables below, evaluation of the SF LED
X	X	On	X	X	You enabled the Force function For details refer to the <i>Programming with STEP 7 Manual</i> .
X	X	Flashes (2 Hz)	X	X	Node flashing test was activated.
Flashes	Flashes	Flashes	Flashes	Flashes	Your CPU has an internal system error. The procedure is as follows: 1. Set the mode selector switch to STOP. 2. Perform POWER ON/OFF. 3. Read the diagnostics buffer with STEP 7. 4. Contact your local SIEMENS partner.

Explanation of the State X:

This status is irrelevant for the current CPU function.

**Reference**

- Details on the OBs and on SFCs required for their evaluation can be found in the *STEP 7 Online Help* and in the Manual *System Software for S7-300/400 - System and Standard Functions*.

**10.7.3 Evaluating the SF LED in case of software errors**

Table 10- 4 Evaluation of the SF LED (Software error)

Possible errors	Response of the CPU	Remedies
TOD interrupt is enabled and triggered. However, a matching block is not loaded. (Software/configuration error)	Call of OB85. CPU goes into STOP if OB85 is not loaded.	Load OB10 (OB number is apparent from the diagnostic buffer).
Start time of the enabled TOD interrupt was jumped, e.g. by advancing the internal clock.	Call of OB80. CPU goes into STOP if OB80 is not loaded	Disable the TOD interrupt before you set the time-of-day with SFC 29.
Delay interrupt triggered by SFC 32. However, a matching block is not loaded. (Software/configuration error)	Call of OB85. CPU goes into STOP if OB85 is not loaded.	Load OB 20 or 21 (CPU 317 only) (the OB number can be viewed in the diagnostic buffer).
Process interrupt is enabled and triggered. However, a matching block is not loaded. (Software/configuration error)	Call of OB85. CPU goes into STOP if OB85 is not loaded.	Load OB40 (OB number is apparent from the diagnostic buffer).
Status alarm is generated, but the appropriate OB55 is not loaded.	Call of OB85. CPU goes into STOP if OB85 is not loaded.	Load OB55
Update alarm is generated, but the appropriate OB 56 is not loaded.	Calls OB85. CPU does not STOP if OB85 is loaded.	Load OB56
Vendor-specific alarm is generated, but the appropriate OB57 is not loaded.	Call of OB85. CPU goes into STOP if OB85 is not loaded.	Load OB57
Access to missing or defective module upon updating the process image (software or hardware error)	Call OB 85 (depending on the configuration in HW Config). CPU goes into STOP if OB 85 is not loaded.	Load OB85, the start information of the OB contains the address of the relevant module. Replace the relevant module or eliminate the program error.

Possible errors	Response of the CPU	Remedies
The cycle time was exceeded. Probably too many interrupt OBs called simultaneously.	Call of OB80. CPU goes into STOP if OB80 is not loaded. The CPU switches to STOP despite loaded OB80 if the doubled cycle time was exceeded without retriggering cycle time 80.	Extension of the cycle time (STEP 7 – Hardware configuration), changing the program structure. Remedy: If necessary, retrigger cycle time monitoring by calling SFC 43
Programming error <ul style="list-style-type: none"> <li>• Block not loaded</li> <li>• Wrong block number</li> <li>• Wrong timer/counter number</li> <li>• Read/write access to wrong area</li> <li>• etc.</li> </ul>	Calls OB121. CPU does not STOP if OB121 is loaded.	Eliminate the programming error. The STEP 7 testing function helps you to locate the error.
I/O access errors An error has occurred when module data was accessed	Calls OB122. CPU does not STOP if OB122 is loaded.	Check module addressing in HW Config or whether a module/DP slave has failed.
Global data communication error, e.g. insufficient length of the DB for global data communication.	Call of OB87. CPU goes into STOP if OB87 is not loaded.	Check global data communication in STEP 7. If required, correct the DB size.

**Tip:**

- You can use SFC 39 to disable all interrupts and asynchronous error events.

---

**Note**

The shorter the selected cyclic interrupt period, the more likely it is that cyclic interrupt errors will occur. You must take into account the operating system times of the CPU in question, the user program runtime and extension of the cycle time by active PG functions, for example.

---

**Reference**

Details on the OBs and on the SFCs required for their evaluation are available in the *STEP 7 Online Help* and in the *System Software for S7-300/400 - System and Standard Functions Reference Manual*.

### 10.7.4 Evaluating the SF LED in case of hardware errors

Table 10- 5 Evaluation of the SF LED (Hardware error)

Possible problem	CPU reaction	Possible remedies
A module was removed or inserted while the system was in RUN.	CPU goes into STOP.	Screw-tighten the modules and restart the CPU.
A distributed module was removed or inserted on PROFIBUS DP while the system was in RUN.	Call of OB86. CPU goes into STOP if OB86 is not loaded. When the module is integrated by means of GSD file: Call of OB 82. CPU goes into STOP when OB 82 is not loaded.	Load OB86 or OB82.
A distributed module was removed or inserted on PROFINET IO while the system was in RUN.	Call of OB83. CPU goes into STOP if OB83 is not loaded. OB 86 is also called when one or several modules of an ET 200S (IO device) are removed or inserted while the system is in RUN. CPU switches to STOP if OB 86 is not loaded.	Load OB 83 and OB 86.
A diagnosable module reports a diagnostic interrupt.	Call of OB82. CPU goes into STOP if OB82 is not loaded.	Reaction to the diagnostic event, based on the module configuration.
Attempt to access a missing or faulty module. Loose connector (software or hardware error).	Call of OB85, if access was attempted during update of the process image (OB 85 call must be enabled accordingly in the parameters). Call of OB 122 with direct I/O access. CPU switches to STOP if the OB is not loaded.	Load OB 85, the start information of the OB contains the address of the relevant module. Replace the relevant module, tighten the plug or eliminate the program error.
Faulty SIMATIC MMC.	The CPU goes into STOP mode and requests memory reset.	Replace the SIMATIC MMC, reset CPU memory, transfer the program again, then set the CPU to RUN mode.

#### Reference

Details on the OBs and on the SFCs required for their evaluation are available in the *STEP 7 Online Help* and in the *System Software for S7-300/400 - System and Standard Functions Reference Manual*.

## 10.7.5 Status and Error Indicators: CPUs with DP Interface

### Description of the BF, BF1 and BF2 LEDs

Table 10-6 LEDs BF, BF1 and BF2

LED					Meaning
SF	5 VDC	BF	BF1	BF2	
On	On	On/ flashes	-	-	PROFIBUS DP interface error. Remedy: See the table below
On	On	-	On/ flashes	X	Fault at the second PROFIBUS DP interface of CPU 317 or CPU 319-3 PN/DP. Remedy: See the table below
On	On	-	X	On/ flashes	Error on the second PROFIBUS DP interface of the CPU 317-2 DP or CPU 319-3 PN/DP. Remedy: See the tables below

Explanation of the State X:

The LED can assume the *On* or *Off* state. This status, however, is irrelevant for the current CPU function. For example, the *Force On* or *Off* states do not influence the CPU STOP status

Table 10-7 BF LED is lit

Possible problem	CPU reaction	Possible remedies
<ul style="list-style-type: none"> <li>Bus fault (hardware fault).</li> <li>DP interface error.</li> <li>Different transmission rates in multiple DP master mode.</li> <li>If the DP slave / master interface is active: short-circuit on the bus.</li> <li>With passive DP slave interface: transmission rate search, i.e. there are no other active nodes on the bus (a master, for example)</li> </ul>	<p>Call of OB 86, if CPU is in RUN mode and if the communication between the DP master and DP slave functioned properly before the error occurred.</p> <p>CPU switches to STOP if OB 86 is not loaded.</p>	<ul style="list-style-type: none"> <li>Check the bus cable for short-circuit or breaks.</li> <li>Analyze the diagnostic data. Edit the configuration.</li> </ul>

Table 10-8 BF LED flashes

Possible problem	CPU reaction	Possible remedies
<p>The CPU is DP master:</p> <ul style="list-style-type: none"> <li>Failure of a connected station</li> <li>At least one of the configured slaves cannot be accessed.</li> <li>Bad engineering configuration</li> </ul>	<p>Call of OB 86, if CPU is in RUN mode and operated DP slaves before the error occurred.</p> <p>CPU switches to STOP if OB 86 is not loaded.</p>	<p>Verify that the bus cable is connected to the CPU, or that the bus is not interrupted.</p> <p>Wait until the CPU has completed its startup. If the LED does not stop flashing, check the DP slaves or evaluate the diagnostic data for the DP slaves.</p>

10.7 Diagnostics using status and error LEDs

Possible problem	CPU reaction	Possible remedies
The CPU is active DP slave Possible causes: <ul style="list-style-type: none"> <li>• The response monitoring time has elapsed.</li> <li>• PROFIBUS DP communication is down.</li> <li>• Wrong PROFIBUS address.</li> <li>• Bad engineering configuration</li> </ul>	Call of OB 86, if CPU is in RUN mode and communicated as a DP slave with the DP master before the error occurred. CPU switches to STOP if OB 86 is not loaded.	<ul style="list-style-type: none"> <li>• Check the CPU.</li> <li>• Verify that the bus connector is properly seated.</li> <li>• Check for breaks in the bus cable to the DP master.</li> <li>• Check the configuration data and parameters.</li> </ul>

Reference

Details on the OBs and on the SFCs required for their evaluation are available

- in the *STEP 7 Online Help*
- in the *System Software for S7-300/400, System and Standard Functions Reference Manual*

10.7.6 Status and Error Indicators: CPUs with PROFINET interface for the S7-300

Status and Error Indicators: PROFINET devices

Note

The RX and TX LEDs can also be grouped in one LED, as with the CPU 319-3 PN/DP. The RX/TX LED on this device is located, for example, under the front cover.

LED	LED status			Description of the status
	Not lit	Flashes	Lit	
LINK	–	–	X	There is no connection between the PROFINET interface of your PROFINET device and a communication partner in the Ethernet (a switch, for example).
	–	X	–	Only with an IO device: The user activated flashing from STEP 7.
	X	–	–	The Ethernet connection between the PROFINET interface of the PROFINET device and the communication partner is down.
RX	–	–	X (flickers)	At the current time, data are being received from a communication partner on Ethernet via PROFINET interface of the PROFINET device.
	X	–	–	No data are currently received via the PROFINET interface.

	LED status			Description of the status
TX	–	–	X (flickers)	Data are currently sent to a communication partner on Ethernet via the PROFINET interface of the PROFINET device.
	X	–	–	No data are currently transmitted via the PROFINET interface.
BF2 or BF3	–	–	X	Error on the PROFINET interface, communication no longer possible (for example, with a CPU as IO controller, when the connection to the switch is down) Remedy: See the table below
	–	X	–	Error on the PROFINET interface (for example, due to station failure of one or more IO devices) Remedy: See the table below
	X	–	–	No error at the PROFINET interface

### Remedy of faults at the PROFINET interface - BF2/ BF3 LED is lit

Table 10- 9 BF2 / BF3 LED is lit

Possible problem	Reaction based on the example of a CPU	Possible remedies
<ul style="list-style-type: none"> <li>• Bus fault (no cable connection to a subnet/switch)</li> <li>• Wrong transmission speed</li> <li>• Full duplex mode not set</li> </ul>	<p>Call of OB 86, if CPU is in RUN mode and operated PNIO slaves before the error occurred.</p> <p>CPU switches to STOP if OB 86 is not loaded.</p>	<ul style="list-style-type: none"> <li>• Check the bus cable for a short-circuit or break.</li> <li>• Check that the module is connected to a switch and not to a hub.</li> <li>• Check that data are being transmitted at 100 Mbps and in full duplex mode.</li> <li>• Analyze the diagnostic data. Edit the configuration.</li> </ul>

### Remedy of faults at the PROFINET interface of an IO controller - BF2 / BF3 LED flashes

Table 10- 10 BF2 / BF3 LED flashes at a PROFINET IO controller

Possible problem	Reaction based on the example of a CPU	Possible remedies
<ul style="list-style-type: none"> <li>• Failure of a connected IO device</li> <li>• At least one of the assigned IO devices cannot be addressed</li> <li>• Bad engineering configuration</li> </ul>	<p>Call of OB 86, if CPU is in RUN mode and operated PNIO slaves before the error occurred.</p> <p>CPU switches to STOP if OB 86 is not loaded.</p>	<ul style="list-style-type: none"> <li>• Check that the Ethernet cable is connected to the module or whether the bus is interrupted.</li> <li>• Wait until the CPU has completed its startup. If the LED does not stop flashing, check the IO devices or evaluate its diagnostic information.</li> <li>• Verify that the configured device name matches its actually assigned name.</li> </ul>

### 10.7.7 Status and Error Indicators: PROFINET IO Devices

#### Remedy with faults at the PROFINET interface of an IO Device - BF LED flashes

Table 10- 11 BF LED flashes on a PROFINET IO device

Possible problem	Possible Remedies
<ul style="list-style-type: none"><li>• The IP address is incorrect</li><li>• Bad engineering configuration</li><li>• Bad parameter assignment</li><li>• IO controller not found / switched off, but there is an Ethernet connection.</li><li>• Bad or no device name</li><li>• The response monitoring time has elapsed.</li></ul>	<ul style="list-style-type: none"><li>• Check that the Ethernet cable is correctly connected.</li><li>• Check whether the Ethernet cable to the controller is interrupted.</li><li>• Check the configuration data and parameters.</li><li>• On the IO device: Switch on the IO controller.</li><li>• Check whether the expected configuration matches the actual configuration.</li><li>• Check the physical communication connection for interruption</li></ul>

#### Tip: Identification of the PROFINET device in the cubicle

When they are first commissioned, PROFINET IO devices must be assigned a device name. In STEP 7/HW Config, you can make the LINK LED of a PROFINET IO device you are naming flash using PLC > **Ethernet** > **Assign Device Name**. This allows you, for example, to clearly identify a PROFINET IO device among several identical devices in a control cabinet.



## 10.8 Diagnostics of DP CPUs

### 10.8.1 Diagnostics of DP CPUs operating as DP Master

#### Evaluate diagnostics in the user program

The figure below illustrates the procedure for evaluating diagnostics data in the user program.

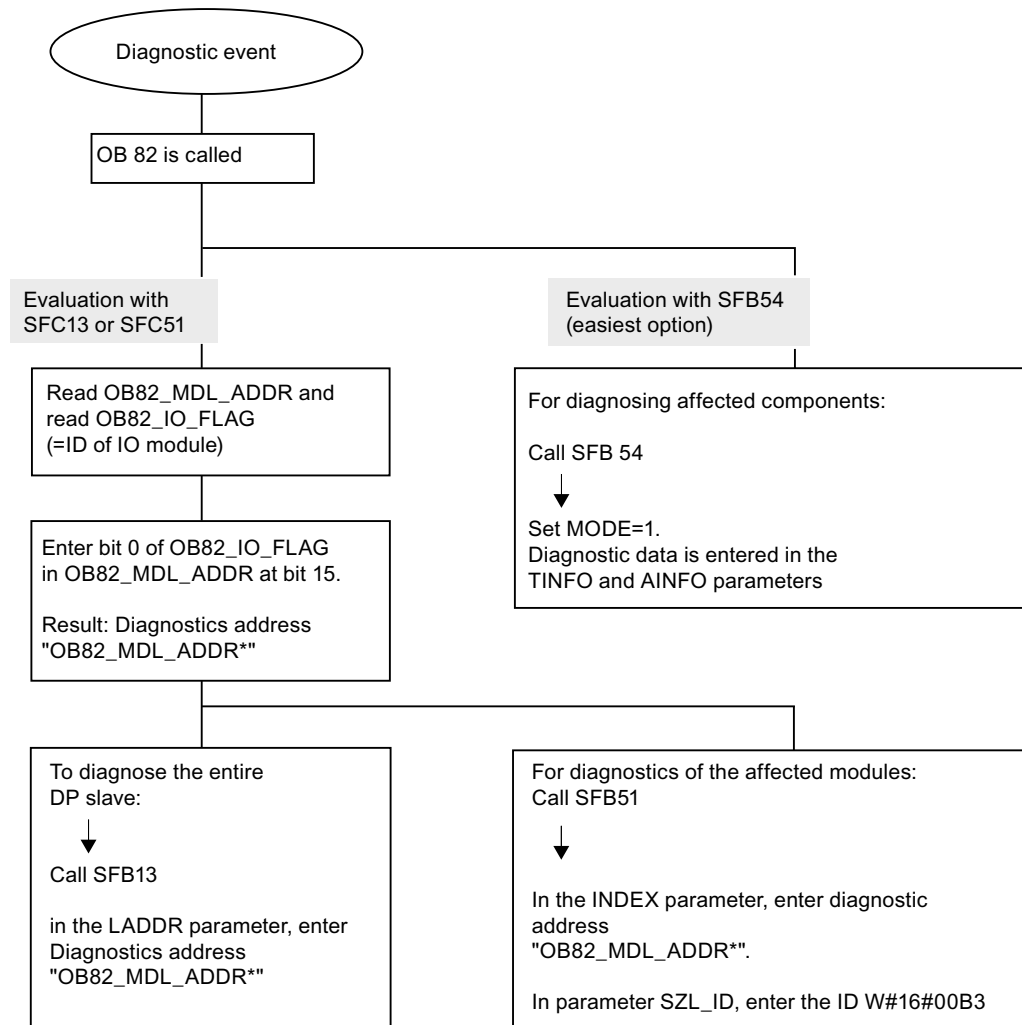

Note:  
 SFC 13 is asynchronous, which means that it may be called multiple times until its state has changed to BUSY=0.

Initial call in OB82,  
 execution completed in the cycle

### Diagnostic addresses for DP masters and DP slaves

At a CPU 31x-2, you assign diagnostic addresses for PROFIBUS DP. Verify in your configuration that the DP diagnostic addresses are assigned once to the DP master and once to the DP slave.

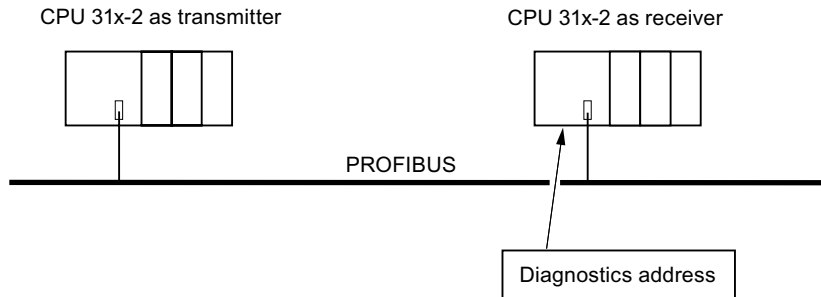

Description of the DP master configuration	Description of the DP slave configuration
<p>When you configure the DP master, assign two different diagnostic addresses for an intelligent slave, that is, one diagnostic address for slot 0, and one for slot 2. Functions of those two addresses:</p> <ul style="list-style-type: none"> <li>• The diagnostic address for slot 0 reports in the master all events relating to the entire slave (station representative), for example, node failure.</li> <li>• The diagnostic address for slot 2 is used to report events concerning this slot. For example, if the CPU is acting as an intelligent slave, it returns the diagnostic interrupts for operating state transitions.</li> </ul> <p>Hereinafter, these diagnostic addresses are referred to as <i>assigned to the DP master</i>.</p> <p>These diagnostic addresses are used by the DP master to obtain information about the status of DP slave, or about bus interruptions.</p>	<p>When you configure the DP slave, you also assign it a diagnostic address (in the associated DP slave project).</p> <p>Below, this diagnostic address is labeled <i>assigned to DP slave</i>.</p> <p>This diagnostic addresses is used by the DP slave to obtain information on the status of the DP master, or on bus interruptions.</p>

## Event detection

The table below shows how a CPU 31x-2 operating as DP master detects operating mode transitions of a CPU operating as DP slave, or data exchange interruptions.

Table 10- 12 Event detection of CPU 31x2 operating as DP master

Event	What happens in the DP master?
Bus interrupt (short-circuit, connector removed)	<ul style="list-style-type: none"> <li>• Call of OB 86 with the message <b>Station failure</b> (incoming event; diagnostic address of Slot 0 of the DP slave that is assigned to the DP master)</li> <li>• with I/O access: call of OB 122 (I/O access error)</li> </ul>
DP slave: RUN → STOP	<ul style="list-style-type: none"> <li>• Call of OB 82 with the message <b>Module error</b> (incoming event; diagnostic address of Slot 2 of the DP slave that is assigned to the DP master; Variable OB82_MDL_STOP=1)</li> </ul>
DP slave: RUN → STOP	<ul style="list-style-type: none"> <li>• Call of OB 82 with the message <b>Module OK</b> (outgoing event; diagnostic address of Slot 2 of the DP slave that is assigned to the DP master; Variable OB82_MDL_STOP=0)</li> </ul>

## Evaluation in the user program

The table below shows how you can, for example, evaluate RUN to STOP transitions of the DP slave in the DP master.

Table 10- 13 Evaluating RUN to STOP transitions of the DP slave in the DP master

In the DP master	In the DP slave (CPU 31x-2 DP)
Diagnostic addresses: (Example) Master diagnostic address = <b>1023</b> Slave diagnostic address = <b>1022</b> (Slot 0 of slave) (Diagnostic) address for "Slot 2"= <b>1021</b> (Slot 2 of slave)	Diagnostic addresses: (Example) Slave diagnostic address = <b>422</b> Master diagnostic address = irrelevant
The CPU calls OB82 with the following information: <ul style="list-style-type: none"> <li>• OB82_MDL_ADDR:=<b>1021</b></li> <li>• OB82_EV_CLASS:=B#16#39 (incoming event)</li> <li>• OB82_MDL_DEFECT: = Module error</li> </ul> Tip: The CPU diagnostic buffer also contains this information In the user program you should also include SFC 13 "DPNRM_DG" for reading out DP slave diagnostic data.	CPU: RUN -> STOP The CPU generates a DP slave diagnostics message frame

### 10.8.2 Reading out slave diagnostic data

The slave diagnostic data is compliant with EN 50170, Volume 2, PROFIBUS. Depending on the DP master, diagnostic data for all DP slaves conforming to standard can be read with STEP 7.

#### Diagnostics addresses for the receiving station with direct data exchange

For direct data exchange, you assign a diagnostic address in the receiving station:

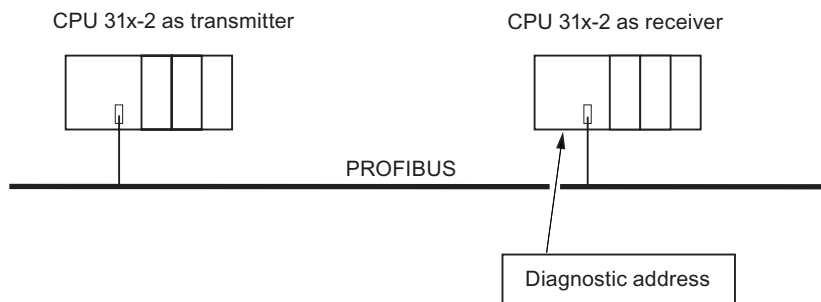

Figure 10-2 PROFIBUS DP diagnostics address

In this figure, you see that assign a diagnostic address to the receiving station in your configuration. The receiving station receives information about the status of the transmitting station or about a bus interruption by means of this diagnostic address.

#### Reading out the diagnostic data

The table below shows you how the various DP master systems can read diagnostic information from a slave.

Table 10- 14 Reading out diagnostic data in the master system, using STEP 5 and STEP 7

Automation system with DP master	Blocks or registers in STEP 7	Application	Further Information
SIMATIC S7/M7	"DP Slave Diagnostics" tab	Output of slave diagnostic data in plain text to a STEP 7 user interface	Found under the keyword <i>Hardware diagnostics</i> in the STEP 7 Online Help and in the <i>Programming with STEP 7 Manual</i>
	SFB 54 "RALRM"	Reading additional interrupt information from a DP slave or local module from the relevant OB.	System and Standard Functions <i>Reference Manual</i>
	SFC13 "DP NRM_DG"	Reading out slave diagnostics (store in the data area of the user program)	System and Standard Functions <i>Reference Manual</i>

Automation system with DP master	Blocks or registers in STEP 7	Application	Further Information
	SFC 51 "RDSYSST"	Reading SSL sublists. In the diagnostic interrupt, call SFC 51 with the SSL ID W#16#00B4, and then read out the SSL of the slave CPU.	System and Standard Functions <i>Reference Manual</i>
	SFB 52 "RDREC" and SFC 59 "RDREC"	Reading the data records of S7 diagnostics (stored in the data area of the user program)	System and Standard Functions <i>Reference Manual</i>
	FB 125/FC 125	Evaluating slave diagnostic data	On the Internet under <a href="http://www.siemens.com/automation/csi_en_WW7Product">http://www.siemens.com/automation/csi_en_WW7Product</a> under the entry ID. 387 257
SIMATIC S5 with IM 308-C operating in DP master mode	FB 192 "IM308C"	Reading slave diagnostic data (store in the data area of the user program)	Distributed I/O System ET 200 <i>Manual</i>

### Example for reading the slave diagnosis with FB 192 "IM308C"

This shows you an example of how to use FB 192 in the **STEP 5** user program to read out slave diagnostics data for a DP slave.

### Assumptions regarding the STEP 5 user program

For this **STEP 5** user program it is assumed that:

- The IM 308-C operating in DP master mode uses the page frames 0 to 15 (number 0 of IM 308-C).
- The DP slave is assigned PROFIBUS address 3.
- Slave diagnostics data should be stored in DB 20. You may also use any other DB.
- Slave diagnostics data consist of 26 bytes.

### STEP 5 user program

STL	Explanation
:A DB 30	
:SPA FB 192	
Name :IM308C	
DPAD : KH F800	//Default address area of IM 308-C
IMST : KY 0, 3	//IM no. = 0, PROFIBUS address of the DP slave = 3
FCT : KC SD	//function: Read slave diagnostics
GCGR : KM 0	//not evaluated
TYP : KY 0, 20	//S5 data area: DB 20
STAD : KF +1	//Diagnostic data starting at data word 1
LENG : KF 26	//Length of diagnostic data = 26 bytes
ERR : DW 0	//Error code storage in DW 0 of DB 30

### Example of reading out S7 diagnostic data with SFC 59 "RD REC"

Here you will find an example of how to use SFC 59 in the STEP 7 user program to read S7 diagnostics data records for a DP slave. The process of reading the slave diagnostics is similar to SFC 13.

### Assumptions regarding the STEP 7 user program

Exceptions for this STEP 7 user program:

- Diagnostic data for the input module at address 200<sub>H</sub> is to be read.
- Data record 1 is to be read out.
- Data record 1 is to be stored in DB 10.

### STEP 7 user program

STL	Explanation
CALL SFC 59	
REQ :=TRUE	//Request to read
IOID :=B#16#54	//Identifier of the address area, here the I/O input
LADDR :=W#16#200	//Logical address of the module
RECNUM :=B#16#1	//Data record 1 is to be read
RET_VAL :=MW2	//An error code is output if an error occurs
BUSY :=MO.0	//Read operation not finished
RECORD :=P# DB10.DBX 0.0 BYTE 240	//DB 10 is target area for the read data record 1

**Note:**

Data is only returned to the target area if BUSY is reset to 0 and if no negative RET\_VAL has occurred.

## Diagnostic addresses

At a CPU 31x-2, you assign diagnostic addresses for PROFIBUS DP. Verify in your configuration that the DP diagnostic addresses are assigned once to the DP master and once to the DP slave.

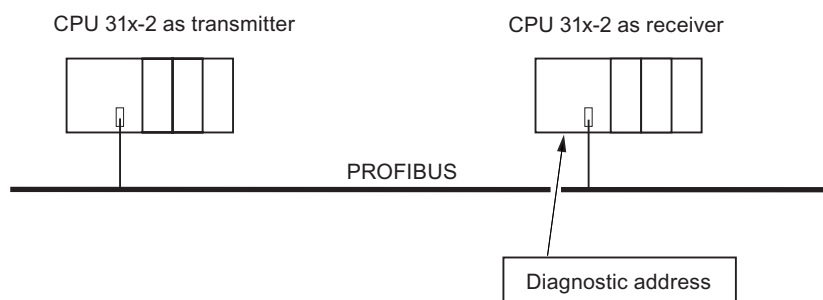

Figure 10-3 PROFIBUS DP diagnostics address

Description of the DP master configuration	Description of the DP slave configuration
<p>When you configure the DP master, assign two different diagnostic addresses for an intelligent slave, that is, one diagnostic address for slot 0, and one for slot 2. Functions of those two addresses:</p> <ul style="list-style-type: none"> <li>• The diagnostics address for slot 0 reports in the master all events relating to the entire slave (station representative), for example, node failure.</li> <li>• The diagnostics address for slot 2 is used to report events concerning this slot. For example, if the CPU is acting as an intelligent slave, it returns the diagnostic interrupts for operating state transitions.</li> </ul> <p>From now on, these diagnostic addresses are referred to as <i>assigned to the DP master</i>.</p> <p>These diagnostic addresses are used by the DP master to obtain information about the status of of DP slave, or about bus interruptions.</p>	<p>When you configure the DP slave, you also assign it a diagnostic address (in the associated DP slave project).</p> <p>Below, this diagnostic address is labeled <i>assigned to DP slave</i>.</p> <p>This diagnostic addresses is used by the DP slave to obtain information on the status of the DP master, or on bus interruptions.</p>

**Event recognition**

The table below shows how CPU 31x-2 operating as DP slave recognized operating state transitions or data exchange interruptions.

Table 10- 15 Event recognition of CPUs 31x-2 operating in DP slave mode

Event	What happens in the DP slave?
Bus interruption (short circuit, connector removed)	<ul style="list-style-type: none"> <li>• Calls OB86 with the message <b>Station failure</b> (incoming event; diagnostic address of the DP slave, assigned to the DP slave)</li> <li>• With I/O access: call of OB 122 (I/O access error)</li> </ul>
DP master RUN → STOP	<ul style="list-style-type: none"> <li>• Calls OB82 with the message <b>Module error</b> (incoming event; diagnostic address of the DP slave assigned to the DP slave; tag OB82_MDL_STOP=1)</li> </ul>
DP master STOP → RUN	<ul style="list-style-type: none"> <li>• Call of OB82 with the message <b>Module OK.</b> (outgoing event; diagnostic address of the DP slave, assigned to the DP slave; tag OB82_MDL_STOP=0)</li> </ul>

**Evaluation in the user program**

The table below shows an example of you how you can evaluate RUN-STOP transitions of the DP master in the DP slave (see also the previous table).

Table 10- 16 Evaluating RUNSTOP transitions in the DP Master/DP Slave

In the DP master	In the DP slave
Diagnostics addresses: (Example) Master diagnostic address = <b>1023</b> Slave diagnostic address in the master system= <b>1022</b> (Slot 0 of slave) (Diagnostic) address for "Slot 2"= <b>1021</b> (Slot 2 of slave)	Diagnostics addresses: (Example) Slave diagnostic address = <b>422</b> Master diagnostic address = irrelevant
CPU: RUN → STOP	→ The CPU calls OB 82 with the following information, for example: <ul style="list-style-type: none"> <li>• OB82_MDL_ADDR:=422</li> <li>• OB82_EV_CLASS:=B#16#39 (incoming event)</li> <li>• OB82_MDL_DEFECT:=module malfunction</li> </ul> Tip: The CPU diagnostic buffer also contains this information



### 10.8.3 Interrupts on the DP Master

#### Interrupts with S7 DP master

##### **Process interrupts from an intelligent slave with SFC 7**

In the CPU 31x-2 operating in DP slave mode, you can trigger a user-defined process interrupt from the DP master from the user program.

A call of SFC 7 "DP\_PRAL" triggers the execution of OB 40 in the user program on the DP master. The SFC 7 allows you to forward interrupt information to the DP master in a double word. This information can then be evaluated in the OB40\_POINT\_ADDR variable in the OB40. The interrupt information can be programmed user-specific. For a detailed description of SFC 7 "DP\_PRAL", refer to the *System Software for S7-300/400 - System and Standard Functions Reference Manual*.

##### **Setting user-defined interrupts of Intelligent Slaves using SFB 75**

In the CPU 31x-2 operating in DP slave mode, you can trigger user-defined interrupts from the user program in the DP master. SFB 75 "SALRM" is used to send a process or diagnostic interrupt from a slot in the transfer area (virtual slot) to the associated DP master from the user program on an intelligent slave. This starts the associated OB on the DP master.

Additional interrupt-specific information may be included. You can read this additional information in the DP master using SFB 54 "RALRM."

#### Interrupts with another DP master

When CPU 31x-2 operates with another DP master, an image of these interrupts is created in its device-specific diagnostic data. You have to post-process the relevant diagnostic events in the DP master's user program.

---

##### **Note**

In order to allow the evaluation of diagnostics and process interrupts by means of device-specific diagnostics using a different DP master, please note that:

The DP master should be able to save the diagnostics messages to its ring buffer. For example, if the DP master can not save the diagnostic messages, only the last incoming diagnostic message would be saved.

In your user program, you have to poll the relevant bits in the device-specific diagnostic data in cyclic intervals. Make allowances for the PROFIBUS DP bus cycle time, for example, to be able to poll these bits at least once and in synchronism to the bus cycle time.

With an IM 308-C operating in DP master mode, you cannot utilize process interrupts in device-specific diagnostics, because only incoming events are reported, rather than outgoing events.

---

### 10.8.4 Structure of the slave diagnostic data when the CPU is operated as intelligent slave

#### Syntax of the diagnostics datagram for slave diagnostics

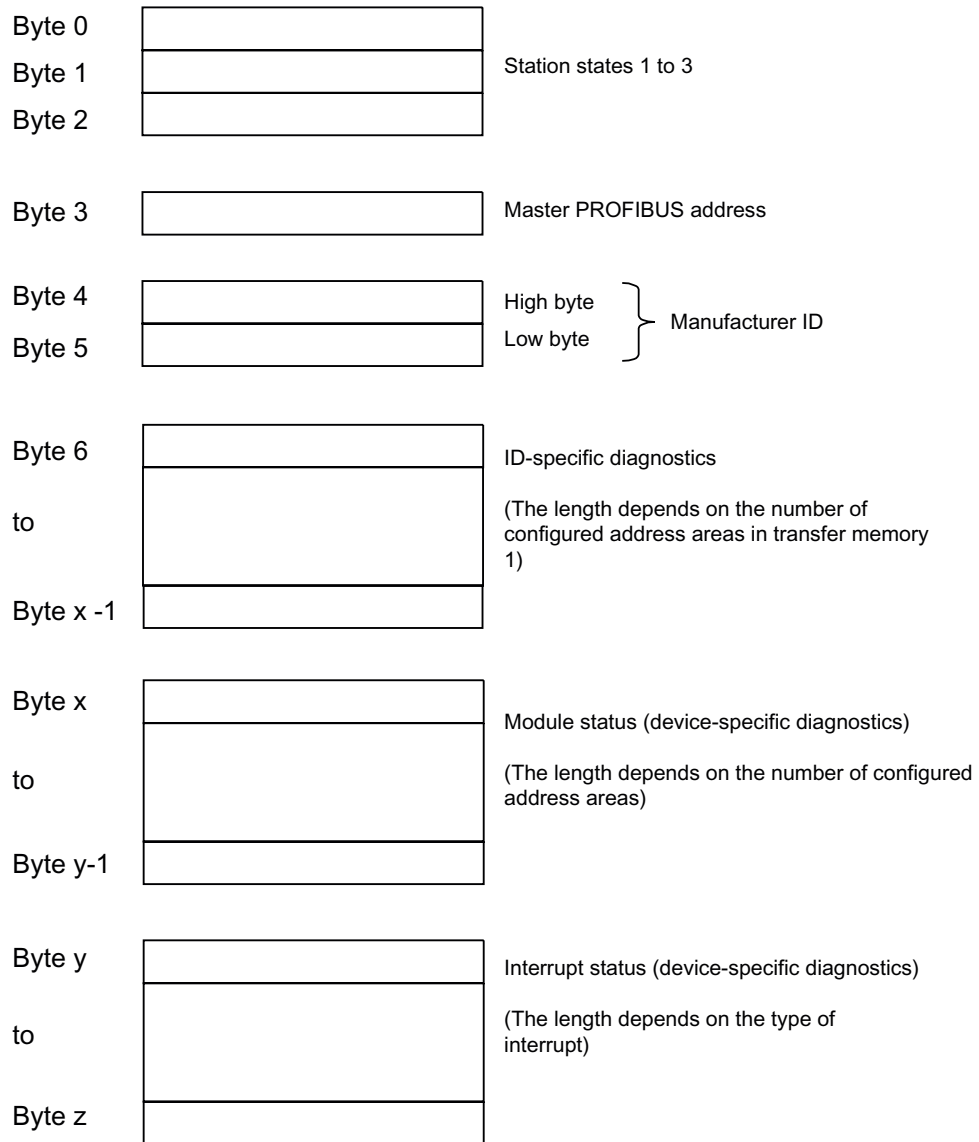

1 Exception: If configuration data from the DP master is incorrect the DP slave interprets 35 configured address spaces (46H in byte 6)

Figure 10-4 Structure of slave diagnostic data

## Station Status 1

Table 10- 17 Structure of station status 1 (Byte 0)

Bit	Meaning	Remedy
0	1: DP slave cannot be addressed by DP master.	<ul style="list-style-type: none"> <li>Is the correct DP address set on the DP slave?</li> <li>Is the bus connector in place?</li> <li>Does the DP slave have power?</li> <li>Correct configuration of the RS485 Repeater?</li> <li>Perform a reset on the DP slave.</li> </ul>
1	1: DP slave is not ready for data exchange.	<ul style="list-style-type: none"> <li>Wait for the slave to complete start-up.</li> </ul>
2	1: Configuration data sent by DP master to the DP slave is inconsistent with slave configuration.	<ul style="list-style-type: none"> <li>Was the software set for the correct station type or DP slave configuration?</li> </ul>
3	1: Diagnostic interrupt, generated by a STOP to RUN transition on the CPU or by the SFB 75 0: Diagnostic interrupt, generated by a STOP to RUN transition on the CPU or by the SFB 75	<ul style="list-style-type: none"> <li>You can read the diagnostic data.</li> </ul>
4	1: Function not supported; e.g. changing the DP address at software level	<ul style="list-style-type: none"> <li>Check configuration data.</li> </ul>
5	0: The bit is always "0".	<ul style="list-style-type: none"> <li>-</li> </ul>
6	1: DP slave type inconsistent with software configuration.	<ul style="list-style-type: none"> <li>Was the software set for the right station type? (parameter assignment error)</li> </ul>
7	1: DP slave was configured by a DP master other than the master currently accessing the slave.	<ul style="list-style-type: none"> <li>The bit is always 1 if, for example, you are currently accessing the DP slave via PG or a different DP master.</li> </ul> <p>The DP address of the parameter assignment master is in the "master PROFIBUS address" diagnostic byte.</p>

## Station Status 2

Table 10- 18 Structure of station status 2 (Byte 1)

Bit	Meaning
0	1: The DP slave requires new parameters and configuration.
1	1: A diagnostic message was received. The DP slave cannot resume operation until the error has been cleared (static diagnostic message).
2	1: This bit is always "1" if a DP slave exists with this DP address.
3	1: The watchdog monitor is enabled on this DP slave.
4	1: DP slave has received control command "FREEZE".
5	1: DP slave has received control command "SYNC".
6	0: The bit is always set to "0".
7	1: DP slave is disabled, that is, it has been excluded from cyclic processing.

### Station Status 3

Table 10- 19 Structure of station status 3 (Byte 2)

Bit	Meaning
0 to 6	0: These bits are always "0"
7	1: The incoming diagnostic messages exceed the memory capacity of the DP slave. The DP master cannot write all diagnostic messages sent by the DP slave to its diagnostic buffer.

### Master PROFIBUS address

The "Master PROFIBUS address" diagnostic byte stores the DP address of the DP master:

- that has configured the DP slave and
- has read and write access to the DP slave.

Table 10- 20 Structure of the Master PROFIBUS address (byte 3)

Bit	Meaning
0 to 7	DP address of the DP master that has configured the DP slave and has read/write access to that DP slave.
	FF <sub>H</sub> : DP slave was not configured by a DP master

### Manufacturer ID

The vendor ID contains a code specifying the type of the DP slave.

Table 10- 21 Structure of the manufacturer ID (byte 4 and 5)

Byte 4	Byte 5	Vendor ID for the CPU
80 <sub>H</sub>	D0 <sub>H</sub>	313C-2-DP
80 <sub>H</sub>	D1 <sub>H</sub>	314C-2-DP
80 <sub>H</sub>	EE <sub>H</sub>	315-2 DP
81 <sub>H</sub>	17 <sub>H</sub>	315-2 PN/DP
80 <sub>H</sub>	F0 <sub>H</sub>	317-2 DP
80 <sub>H</sub>	F1 <sub>H</sub>	317-2 PN/DP
81 <sub>H</sub>	1D <sub>H</sub>	319-3 PN/DP

### Structure of identifier-related diagnostics of CPU 31x-2 / CPU 319-3

Module diagnostics indicate the configured address area of intermediate memory that has received an entry.

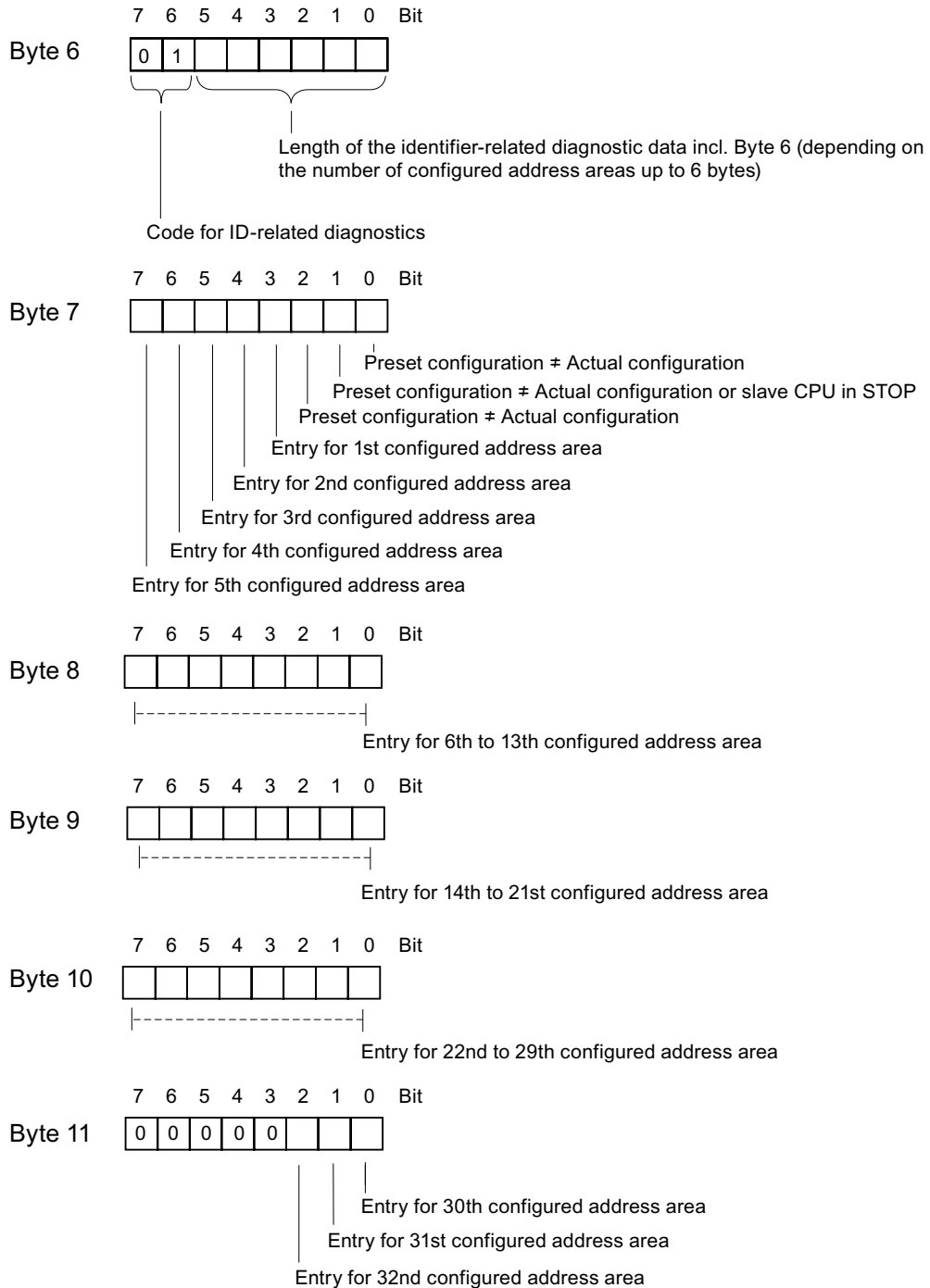

Figure 10-5 Identifier-related diagnostic data

**Structure of the module status**

The module status reflects the status of the configured address areas, and provides detailed ID-specific diagnostics with respect to the configuration. Module status starts with module diagnostics and consists of a maximum of 13 bytes.

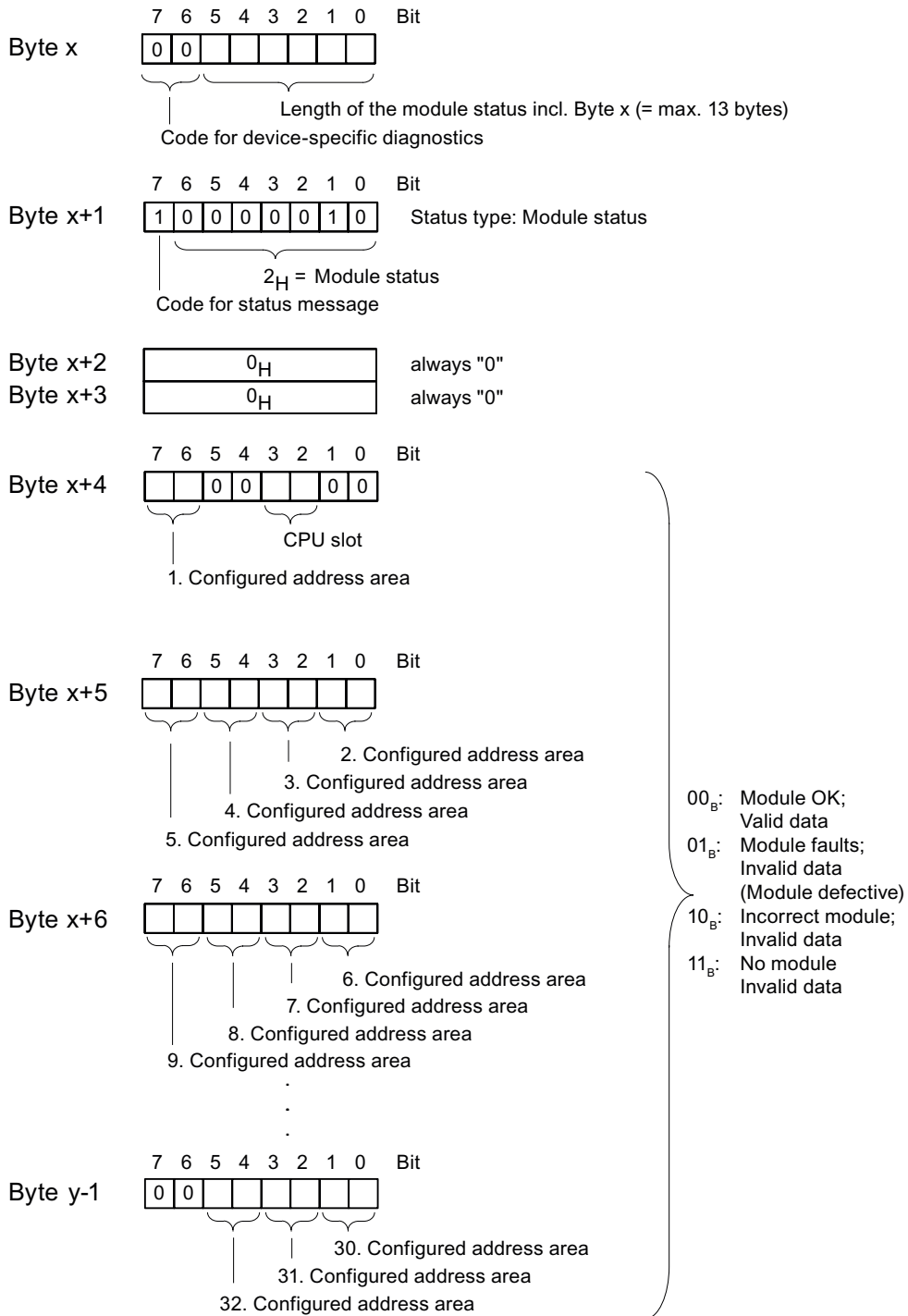
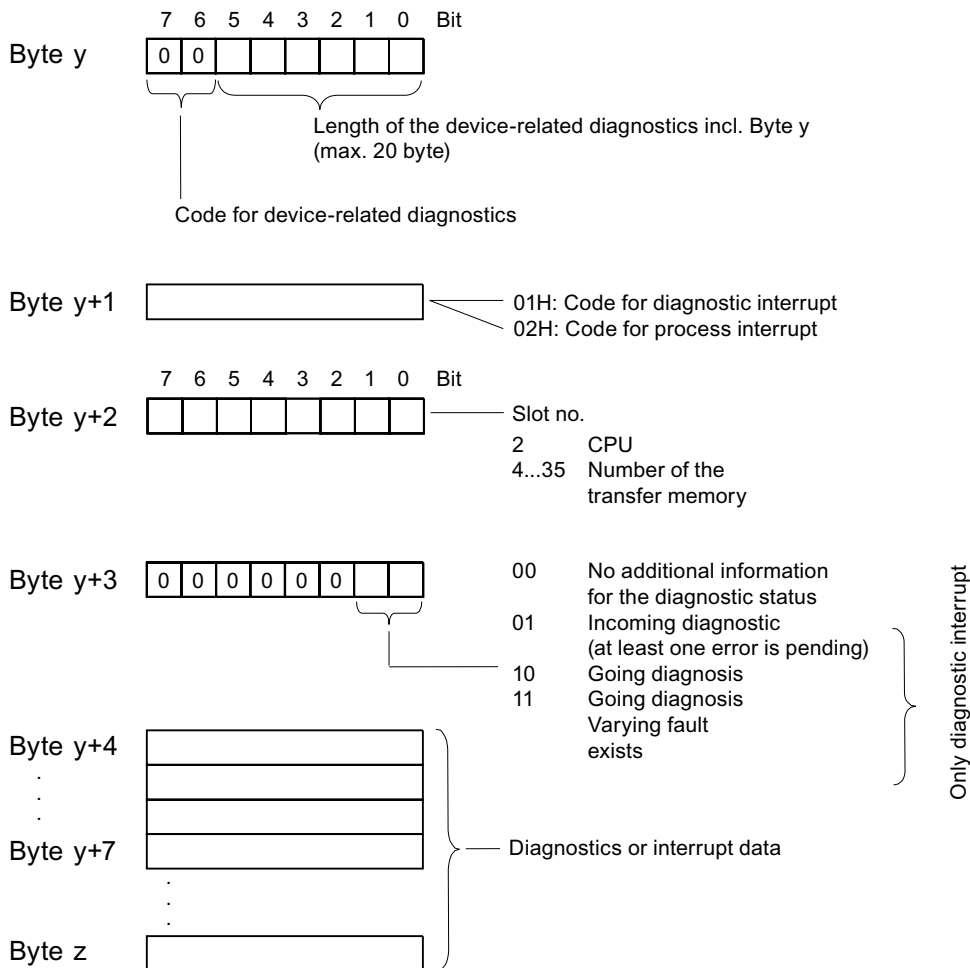

Figure 10-6 Structure of the module status for CPU 31xC

### Structure of the interrupt status:

The interrupt status of module diagnostics provides details on a DP slave. Device-specific diagnostics starts at byte y and has a maximum length of 20 bytes.

The following figure describes the structure and content of the bytes for a configured address area of transfer memory.



Example for Byte y+2:  
 CPU: =02<sub>H</sub>  
 1. Address area: =04<sub>H</sub>  
 2. Address area: =05<sub>H</sub>  
 etc.

Figure 10-7 Device-specific diagnostics

### Structure of the interrupt data for a process interrupt (from byte y+4)

When a process interrupt occurs (code 02<sub>H</sub> for process interrupt in byte y+1), 4 bytes of interrupt information after byte y+4 are transferred. These 4 bytes are transferred to the intelligent slave using SFC 7 "DP\_PRAL" or SFC 75 "SALRM" when the process interrupt for the master was generated.

**Structure of the interrupt data when a diagnostic interrupt is generated in response to an operating status change by the intelligent slave (after byte y+4)**

Byte y+1 contains the code for a diagnostic interrupt (01<sub>H</sub>). The diagnostic data contains the 16 bytes of status information from the CPU. The figure below shows the allocation of the first four bytes of diagnostic data. The next 12 bytes are always 0.

The data in these bytes correspond to the contents of data record 0 of diagnostic data in **STEP 7 (in this case, not all bits are used)**.

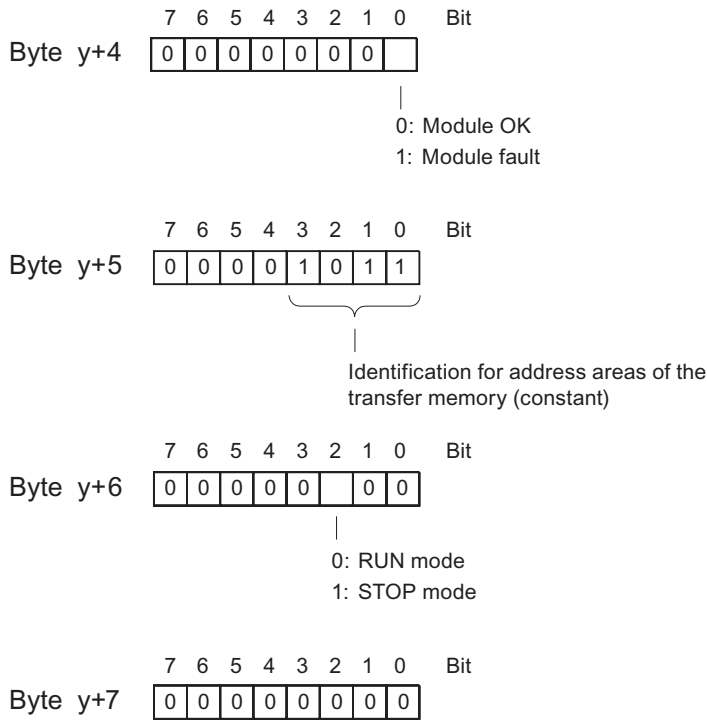

Note: Byte y+8 to Byte y+19 are always 0.

Figure 10-8 Bytes y+4 to y+7 for a diagnostic interrupt (operating status change by intelligent slave)



**Structure of the interrupt data when a diagnostic interrupt is generated by SFB 75 on the intelligent slave (after byte y+4)**

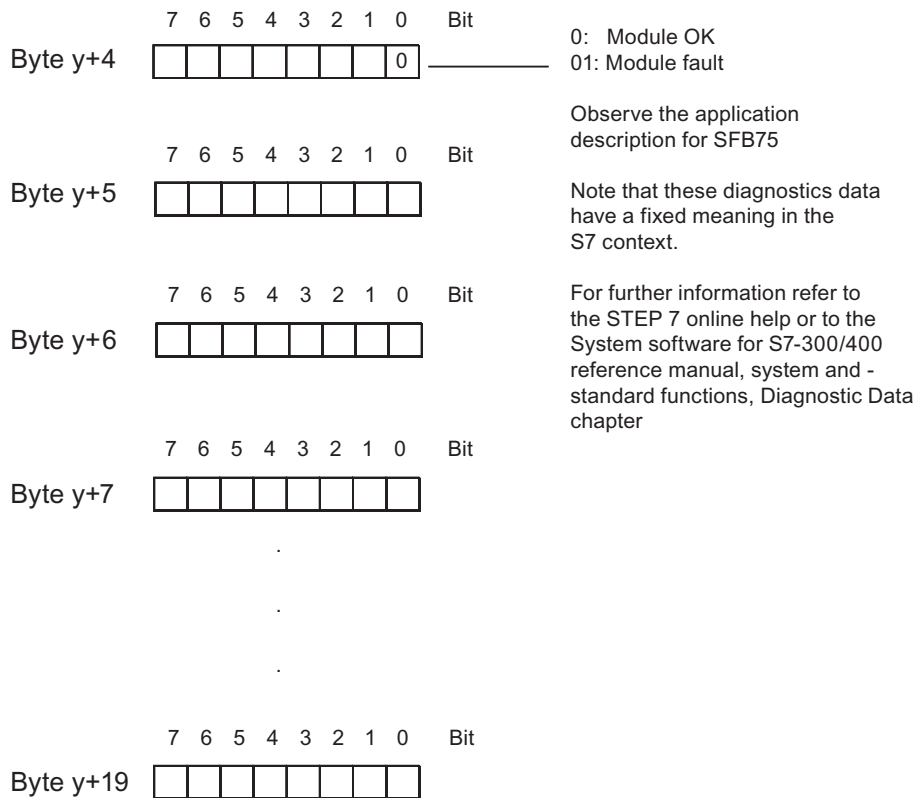

Figure 10-9 Bytes y+4 to y+19 for the diagnostics interrupt (SFB75)

## 10.9 Diagnostics of PROFINET CPUs

### 10.9.1 Diagnostics options of PROFINET IO

#### Diagnostics Concept

PROFINET IO supports you with an integrated diagnostics concept. The diagnostics concept of PROFINET IO is similar to that of PROFIBUS DP.

The diagnostics functions allow you

- to react to an error (event-related diagnostics, evaluation of interrupts) or
- to check the current status of the AS (status-related diagnostics).

#### Overview of diagnostics information

You have three options of obtaining diagnostics information:

1. Diagnostics using status LEDs

Diagnostics option	Benefits	For detailed information refer ...
LEDs on a PROFINET interface	The LED displays indicate: <ul style="list-style-type: none"> <li>• whether data are being sent or received</li> <li>• communication error.</li> </ul>	this manual, chapter: Status and Error Indicators: CPUs with PROFINET interface for the S7-300

2. Diagnostics using the STEP 7 and NCM PC configuration and engineering tool

Diagnostics option	Benefits	For detailed information refer ...
Online diagnostics using a PG/PC/HMI	This allows you to evaluate the current status of your automation system.	the System Manual: PROFINET System Description, chapter: Support by STEP 7/NCM PC
Reporting system errors	Diagnostic information is output in plain text format to the PC / HMI.	the System Manual: PROFINET System Description, chapter: Support by STEP 7/NCM PC
Network diagnostics	The SNMP protocol allows you to determine the network infrastructure	this manual, chapter: Network infrastructure diagnostics (SNMP)

3. Diagnostics in the STEP 7 user program

Diagnostics option	Benefits	For detailed information refer ...
Reading system status lists (SSLs)	The SSLs will help you to track down an error.	the System Manual: PROFINET System Description, chapter: Evaluation of Diagnostics in the User Program Reference manual: System software for S7-300/400 System and Standard Functions
Reading diagnostics data records	You can obtain detailed information about the type and source of faults by reading the diagnostic data records.	the System Manual: PROFINET System Description, chapter: Evaluation of Diagnostics in the User Program
Diagnostics interrupt	Can be used to evaluate diagnostics data in the user program.	the System Manual: PROFINET System Description, chapter: Evaluation of Diagnostics in the User Program

### Evaluation of diagnostics information

PROFINET IO supports a vendor-independent structure of data records with diagnostics information. Diagnostics information is only generated for faulty channels.

The SSLs, SFB54 and SFB52 were enhanced in order to include information about the status of the PROFINET IO systems and the diagnostics information for an S7 user program:

- Call SFC51 (read system status lists) to read module status information of the PROFINET IO system from SSL 0x0X91.
- Call SFB52 (read data record) to read status-related diagnostics data records directly from a faulty module.
  - Status-related diagnostics data represent error information, for example.
- Call SFB54 (read additional interrupt info) in the corresponding error OB to read event-related diagnostics data records from a module.
  - Event-related diagnostics data represent interrupt information of the error OBs, for example.

### Further Information

Further information about diagnostics and diagnostics data, on the structure of diagnostics data records and on SSLs for PROFINET is available in:

- the *From PROFIBUS DP to PROFINET IO Programming Manual*
- the *PROFINET System Description System Manual*
- the *System Software for S7-300/400, System and Standard Functions Reference Manual*
- in the *STEP 7 Online Help*

## 10.9.2 Maintenance

### Enhanced maintenance concept

PROFINET devices support the comprehensive diagnostics and maintenance concept according to the IEC 61158-6-10 standard.

In addition to "ok" and "faulty" information, the PROFINET components can also display information for preventive maintenance when operating with STEP 7 V5.4 Servicepack 1 or higher.

Preventive maintenance is displayed, for example, if the attenuation of a fiber optic cable deteriorates.

### Maintenance information

Maintenance information returns maintenance priorities. The concept distinguishes between maintenance information based on two levels:

Maintenance information	Symbol in STEP 7	Example
Maintenance requirement (maintenance required): Maintenance recommended	green wrench	The attenuation on a fiber-optic conductor is becoming too high. Although operation is still possible, the transmission link may fail completely in the near future.
Maintenance request (maintenance demanded): Maintenance required	yellow wrench	Failure of the synchronization master in a synchronization domain for the IRT operation of a PNIO system.

### Further Information

Further information is available in:

- the *From PROFIBUS DP to PROFINET IO* Programming Manual
- the *PROFINET System Description* System Manual
- in the *STEP 7 Online Help*

### See also

Diagnostics options of PROFINET IO (Page 226)

## General technical data

### 11.1 Standards and approvals

#### Introduction

Contents of general technical data:

- standards and test values satisfied by modules of the S7-300 automation system
- test criteria of S7-300 modules.

#### CE Label



The S7-300 automation system satisfies requirements and safety-related objectives according to EC Directives listed below, and conforms with the harmonized European standards (EN) for programmable controllers announced in the Official Journals of the European Community:

- 2006/95/EC "Electrical Equipment Designed for Use within Certain Voltage Limits" (LowVoltage Directive)
- 2004/108/EC "Electromagnetic Compatibility" (EMC Directive)
- 94/9/EC "Equipment and protective systems intended for use in potentially explosive atmospheres" (Explosion Protection Directive)

The EC declaration of conformity is held on file available to competent authorities at:

Siemens Aktiengesellschaft  
Automation & Drives  
A&D AS RD ST PLC  
PO Box 1963  
D-92209 Amberg

### UL approval



Underwriters Laboratories Inc. complying with

- UL 508 (Industrial Control Equipment)

### CSA approval



Canadian Standards Association to

- C22.2 No. 142 (Process Control Equipment)

or



Underwriters Laboratories Inc. complying with

- UL 508 (Industrial Control Equipment)
- CSA C22.2 No. 142 (Process Control Equipment)

or



HAZ. LOC.

Underwriters Laboratories Inc. complying with

- UL 508 (Industrial Control Equipment)
- CSA C22.2 No. 142 (Process Control Equipment)
- UL 1604 (Hazardous Location)
- CSA-213 (Hazardous Location)

APPROVED for use in

Class I, Division 2, Group A, B, C, D Tx;

Class I, Zone 2, Group IIC Tx

**Note**

Currently valid approvals can be found on the rating plate of the relevant module.

**FM approval**



Factory Mutual Research (FM) to  
Approval Standard Class Number 3611, 3600, 3810  
APPROVED for use in Class I, Division 2, Group A, B, C, D Tx;  
Class I, Zone 2, Group IIC Tx

**ATEX approval**



to EN 60079-15:2003 (Electrical apparatus for potentially explosive atmospheres; Type of protection "n")



II 3 G Ex nA II Parts 4 to 6

**⚠ WARNING**

Personal injury and property damage can occur.

In potentially explosive environments, there is a risk of injury or damage if you disconnect any connectors while the S7-300 is in operation.

Always isolate the S7-300 operated in such areas before you disconnect and connectors.

**⚠ WARNING**

**Explosion hazard**

Components may no longer qualify for Class I, DIV. 2 if they are replaced.

**⚠ WARNING**

This device is only appropriate for use in Class I, Div. 2, Group A, B, C, D, or in non-hazardous areas.

### Tick-mark for Australia



The S7-300 automation system satisfies requirements of standards to AS/NZS 2064 (Class A).

### IEC 61131

The S7-300 automation system satisfies requirements and criteria to IEC 61131-2 (Programmable Controllers, Part 2: Equipment requirements and tests).

### Marine approval

Classification societies:

- ABS (American Bureau of Shipping)
- BV (Bureau Veritas)
- DNV (Det Norske Veritas)
- GL (Germanischer Lloyd)
- LRS (Lloyds Register of Shipping)
- Class NK (Nippon Kaiji Kyokai)

### Use in industrial environments

SIMATIC products are designed for industrial applications.

Table 11- 1 Use in industrial environments

Field of application	Noise emission requirements	Noise immunity requirements
Industry	EN 61000-6-4: 2001	EN 61000-6-2: 2001



## Use in residential areas

To operate an S7-300 in a residential area, its RF emission must comply with Limit Value Class B to EN 55011.

The following measures are recommended to ensure the interference complies with limit value class B:

- S7-300 installation in grounded switch cabinets / cubicles
- Use of noise filters in the supply lines

 **WARNING**

Personal injury and damage to property may occur.

In potentially explosive environments, there is a risk of injury or damage if you disconnect any connectors while the S7-300 is in operation.

Always isolate the S7-300 operated in such areas before you disconnect and connectors.

## 11.2 Electromagnetic compatibility

### Definition

Electromagnetic compatibility (EMC) is the ability of an electrical installation to function satisfactorily in its electromagnetic environment without interfering with that environment.

The S7-300 modules also satisfy requirements of EMC legislation for the European domestic market. Compliance of the S7-300 system with specifications and directives on electric design is prerequisite.

### Pulseshaped disturbance

The table below shows the EMC compatibility of S7 modules in areas subject to pulse-shaped disturbance.

Pulse-shaped disturbance	Test voltage	corresponds with degree of severity
Electrostatic discharge to IEC 61000-4-2	Air discharge: $\pm 8$ kV	3
	Contact discharge $\pm 4$ kV	2
Burst pulses (high-speed transient disturbance) to IEC 61000-4-4.	2 kV (power supply lines)	3
	2 kV (signal lines > 3 m)	3
	1 kV (signal lines < 3 m)	
High-energy single pulse (surge) to IEC 61000-4-5 External protective circuit required (refer to <i>S7-300 Automation System, Hardware and Installation</i> , Chapter "Lightning and overvoltage protection")		3
<ul style="list-style-type: none"> <li>asymmetric coupling</li> </ul>	2 kV (power supply lines) DC with protective elements 2 kV (signal/ data line only > 3 m), with protective elements as required	
<ul style="list-style-type: none"> <li>symmetric coupling</li> </ul>	1 kV (power supply lines) DC with protective elements 1 kV (signal/ data line only > 3 m), with protective elements as required	

### Additional measures

When connecting an S7-300 system to the public network, always ensure compliance with Limit Value Class B to EN 55022.

### Sinusoidal disturbance

The table below shows the EMC compatibility of S7-300 modules in areas subject to sinusoidal disturbance.

Sinusoidal disturbance	Test values	corresponds with degree of severity
RF radiation (electromagnetic fields) to IEC 61000-4-3	10 V/m, with 80% amplitude modulation of 1 kHz in the 80 MHz to 1000 MHz range 10 V/m, with 50% pulse modulation at 900 MHz	3
RF conductance on cables and cable shielding to IEC 61000-4-6	Test voltage 10 V, with 80% amplitude modulation of 1 kHz in the 9 MHz to 80 MHz range	3

### Emission of radio interference

Electromagnetic interference to EN 55011: Limit Class A, Group 1 (measured at a distance of 10 m.)

Frequency	Noise emission
30 MHz to 230 MHz	< 40 dB ( $\mu$ V/m)Q
230 MHz to 1000 MHz	< 47 dB ( $\mu$ V/m)Q

Noise emission via AC mains to EN 55011: Limit value class A, Group 1.

Frequency	Noise emission
0.15 MHz to 0.5 MHz	< 79 dB ( $\mu$ V/m)Q < 66 dB ( $\mu$ V/m)M
0.5 MHz to 5 MHz	< 73 dB ( $\mu$ V/m)Q < 60 dB ( $\mu$ V/m)M
5 MHz to 30 MHz	< 73 dB ( $\mu$ V/m)Q < 60 dB ( $\mu$ V/m)M

## 11.3 Transportation and storage conditions for modules

### Introduction

The shipping and storage conditions of S7-300 modules surpass requirements to IEC 61131-2. The data below apply to modules shipped or put on shelf in their original packing.

The modules are compliant with climatic conditions to IEC 60721-3-3, Class 3K7 (storage), and with IEC 60721-3-2, Class 2K4 (shipping.)

Mechanical conditions are compliant with IEC 60721-3-2, Class 2M2.

### Shipping and storage conditions for modules

Type of condition	Permissible range
Free fall (in shipping package)	$\leq 1$ m
Temperature	- 40 °C to + 70 °C
Barometric pressure	1080 hPa to 660 hPa (corresponds with an altitude of -1000 m to 3500 m)
Relative humidity	10% to 95%, no condensation
Sinusoidal oscillation to IEC 60068-2-6	5 Hz to 9 Hz: 3.5 mm 9 Hz to 150 Hz: 9.8 m/s <sup>2</sup>
Shock to IEC 60068-2-29	250 m/s <sup>2</sup> , 6 ms, 1000 shocks

## 11.4 Mechanical and climatic environmental conditions for S7-300 operation

### Operating conditions

S7-300 systems are designed for stationary use in weather-proof locations. The operating conditions surpass requirements to DIN IEC 60721-3-3.

- Class 3M3 (mechanical requirements)
- Class 3K3 (climatic requirements)

### Use with additional measures

The S7-300 may not be used under the conditions outlined below without taking additional measures:

- at locations with a high degree of ionizing radiation
- in aggressive environments caused, for example, by
  - the development of dust
  - corrosive vapors or gases
  - strong electric or magnetic fields
- in installations requiring special monitoring, for example
  - elevators
  - electrical plants in potentially hazardous areas

An additional measure could be an installation of the S7-300 in a cabinet or housing.

### Mechanical environmental conditions

The table below shows the mechanical environmental conditions in the form of sinusoidal oscillations.

Frequency band	Continuous	Infrequently
10 Hz ≤ f ≤ 58 Hz	0.0375 mm amplitude	0.75 mm amplitude
58 Hz ≤ f ≤ 150 Hz	0.5 g constant acceleration	1 g constant acceleration

### Reducing vibrations

If your S7-300 modules are exposed to severe shock or vibration, take appropriate measures to reduce acceleration or the amplitude.

We recommend the installation of the S7-300 on damping materials (for example, rubber-bonded-to-metal mounting.)

**Test of mechanical environmental conditions**

The table below provides important information with respect to the type and scope of the test of ambient mechanical conditions.

Condition tested	Test Standard	Comment
Vibration	Vibration test to IEC 60068-2-6 (sinusoidal)	Type of oscillation: Frequency sweeps with a rate of change of 1 octave/minute. 10 Hz ≤ f ≤ 58 Hz, constant amplitude 0.075 mm 58 Hz ≤ f ≤ 150 Hz, constant acceleration 1 g Duration of oscillation: 10 frequency sweeps per axis at each of three vertically aligned axes
Shock	Shock, tested to IEC 60068-2-27	Type of shock: half-sine Severity of shock: 15 g peak value, 11 ms duration Direction of shock: 3 shocks in each direction (+/-) at each of three vertically aligned axes
Continuous shock	Shock, tested to IEC 60068-2-29	Type of shock: Half-sine Shock intensity: 25 g peak value, 6 ms duration Shock direction: 1000 shocks in each direction (+/-) at each of three vertically aligned axes

**Climatic environmental conditions**

The S7-300 may be operated on following environmental conditions:

Environmental conditions	Permissible range	Comments
Temperature: horizontal mounting position: vertical mounting position:	0°C to 60°C 0°C to 40°C	-
Relative humidity	10 % to 95 %	No condensation, corresponds to relative humidity (RH) Class 2 to IEC 61131, Part 2
Barometric pressure	1080 hPa to 795 hPa	Corresponds with an altitude of -1000 m to 2000 m
Concentration of pollutants	SO <sub>2</sub> : < 0.5 ppm; RH < 60 %, no condensation H <sub>2</sub> S: < 0.1 ppm; RH < 60 %, no condensation	Test: 10 ppm; 4 days Test: 1 ppm; 4 days
	ISA-S71.04 severity level G1; G2; G3	-

## 11.5 Specification of dielectric tests, protection class, degree of protection, and rated voltage of S7-300

### Test voltage

Proof of dielectric strength must be provided in the type test at a test voltage to IEC 61131-2:

Circuits with rated voltage $V_e$ to other circuits or ground.	Test voltage
< 50 V	500 VDC
< 150 V	2500 VDC
< 250 V	4000 VDC

### Protection class

Protection class I to IEC 60536, i.e., a protective conductor must be connected to the mounting rail!

### Protection against the ingress of foreign matter and water

- Degree of protection IP 20 to IEC 60529, i.e., protection against contact with standard probes.

No protection against the ingress of water.

## 11.6 Rated voltages of S7-300

### Rated operating voltages

The S7-300 modules operate at different rated voltages. The table shows the rated voltages and corresponding tolerances.

Rated voltages	Tolerance
24 VDC	20.4 VDC to 28.8 VDC
120 VAC	93 VAC to 132 VAC
230 VAC	187 VAC to 264 VAC





## Appendix

### A.1 General rules and regulations for S7-300 operation

#### Introduction

Seeing that an S7-300 can be used in many different ways, we can only describe the basic rules for the electrical installation in this document.

 <b>WARNING</b>
<p>Always observe these basic rules for electrical installation in order to achieve a fully functional S7-300 system.</p>

#### EMERGENCY-OFF equipment

EMERGENCY-OFF equipment to IEC 204 (corresponds to VDE 113) must remain effective in all operating modes of the plant or system.

#### System startup after specific events

The table below shows what you have to observe when restarting a plant after specific events.

Table A- 1 System startup after specific events

If there is...	then ...
Restart following a voltage dip or power failure,	dangerous operating states must be excluded. If necessary, force EMERGENCY-OFF.
Startup after releasing the EMERGENCY OFF device,	uncontrolled or undefined startup operations must be excluded.

## Mains voltage

The table below shows what you have to watch with respect to the mains voltage.

Table A- 2 Mains voltage

In the case of ...	the ...
Stationary systems or systems without all-pole mains disconnect switch	building installation must contain a mains disconnect switch or a fuse.
Load power supplies, power supply modules	set rated voltage range must correspond to local mains voltage.
All circuits of the S7-300	rated mains voltage fluctuation / deviation must lie within the permitted tolerance (refer to Technical Data of S7-300 modules).

## 24 VDC power supply

The table below shows what you must observe for the 24 VDC power supply.

Table A- 3 Protection against external electrical interference

In the case of ...	you need to observe ...	
Buildings	external lightning protection	Install lightning protection (e.g. lightning conductors).
24 VDC power supply cables, signal cables	internal lightning protection	
24 VDC power supply	safe (electrical) extra-low voltage isolation	

## Protection against external electrical interference

The table below shows how you must protect your system against electrical interference or faults.

Table A- 4 Protection against external electrical interference

In the case of ...	Make sure that ...
All plants or system in which the S7-300 is installed	the plant or system is connected to a protective conductor for the discharge of electromagnetic interference.
Supply / signal / bus cables	the cable routing and installation is correct.
Signal and bus cables	a cable/conductor break does not cause undefined plant or system states.

## A.2 Protection against electromagnetic interference

### A.2.1 Basic Points for EMC-compliant system installations

#### Definition: EMC

EMC (electromagnetic compatibility) describes the capability of electrical equipment to operate free of errors in a given electromagnetic environment, without being subject to external influence and without influencing external devices in any way.

#### Introduction

Although your S7-300 and its components are developed for an industrial environment and high electromagnetic compatibility, you should draw up an EMC installation plan before you install the controller taking into consideration all possible sources of interference.

#### Possible interferences

Electromagnetic interference can influence a PLC in various ways:

- Electromagnetic fields having a direct influence on the system
- Interference coupling caused by bus signals (PROFIBUS DP etc.)
- Interference coupling via the system wiring
- Interference influencing the system via the power supply and/or protective ground

The figure below shows the likely paths of electromagnetic interference.

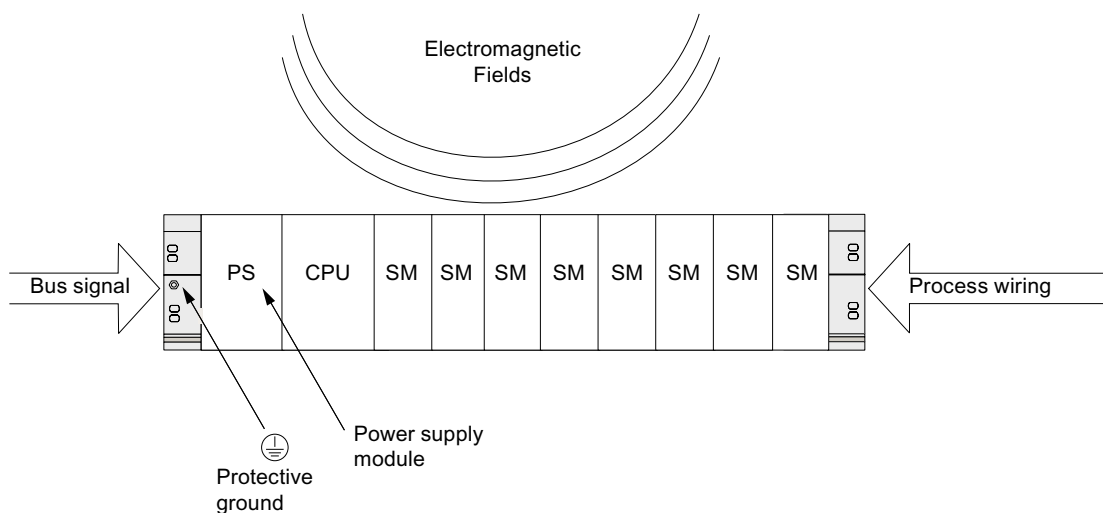

## Coupling mechanisms

Depending on the emitting media (line or isolated) and the distance between the interference source and the device, four different coupling mechanisms can influence the PLC.

Table A- 5 Coupling mechanisms

Coupling mechanisms	Cause	Typical interference sources
Electrical coupling	Electrical or mechanical coupling always occurs when two circuits use one common cable.	<ul style="list-style-type: none"> <li>• Clocked devices (influence on the network due to converters and third-party power supply modules)</li> <li>• Starting motors</li> <li>• Potential differences on component enclosures with common power supply</li> <li>• Static discharge</li> </ul>
Capacitive coupling	Capacitive or electrical coupling occurs between conductors connected to different potentials. The coupling effect is proportional to voltage change over time.	<ul style="list-style-type: none"> <li>• Interference coupling due to parallel routing of signal cables</li> <li>• Static discharge of the operator</li> <li>• Contactors</li> </ul>
Inductive coupling	Inductive or magnetic coupling occurs between two current circuit loops. Current flow in magnetic fields induces interference voltages. The coupling effect is proportional to current change over time.	<ul style="list-style-type: none"> <li>• Transformers, motors, arc welding devices</li> <li>• Power supply cables routed in parallelism</li> <li>• Switched cable current</li> <li>• High-frequency signal cable</li> <li>• Coils without suppression circuit</li> </ul>
Radio frequency coupling	Radio frequency coupling occurs when an electromagnetic wave reaches a conductor system. This wave coupling induces currents and voltages.	<ul style="list-style-type: none"> <li>• Neighboring transmitters (e.g. radio phones)</li> <li>• Sparking (spark plugs, collectors of electrical motors, welding devices)</li> </ul>

## A.2.2 Five basic rules for securing EMC

### A.2.2.1 1. Basic rule for ensuring EMC

If you comply with these five basic rules ...

you can ensure EMC in many cases!

#### Rule 1: Large area grounding contact

When you install the automation equipment, make sure that the surfaces of inactive metal parts are properly bonded to chassis ground.

- Bond all passive metal parts to chassis ground, ensuring large area and low-impedance contact.
- When using screw connections on varnished or anodized metal parts, support contact with special contact washers or remove the protective insulating finish on the points of contact.
- Wherever possible, avoid the use of aluminum parts for ground bonding. Aluminum oxidizes very easily and is therefore less suitable for ground bonding.
- Create a central connection between chassis ground and the equipotential grounded/protective conductor system.

### A.2.2.2 2. Basic rule for ensuring EMC

#### Rule 2: Proper cable routing

Always ensure proper cable routing when wiring your system.

- Sort your wiring system into groups (high-voltage/power supply/signal/data cables).
- Always route high-voltage, signal or data cables through separated ducts or in separate bundles.
- Install the signal and data cables as close as possible to grounded surfaces (e.g. supporting beams, metal rails, steel cabinet walls ).

#### See also

Cable routing inside buildings (Page 256)

Outdoor routing of cables (Page 258)

### A.2.2.3 3. Basic rule for ensuring EMC

#### Rule 3: Fixing the cable shielding

Ensure proper fixation of the cable shielding.

- Always use shielded data cable. Always connect both ends of the shielding to ground on a large area.
- Analog cables must always be shielded. For the transmission of low-amplitude signals it might prove to be more efficient to have only one side of the shielding connected to ground.
- Directly behind the cable entry in the cabinet or enclosure, terminate the shielding on a large area of the shielding/protective ground bar and fasten it with the help of a cable clamp. Then, route the cable to the module; however, do not connect the shielding once again to ground in this place.
- Connections between the shielding/protective ground conductor bar and the cabinet/enclosure must be of a low impedance.
- Always install shielded data cables in metal/metallized connector housings.

#### See also

Cable shielding (Page 252)

### A.2.2.4 4. Basic rule for ensuring EMC

#### Rule 4: Special EMC measures

Take special EMC measures for particular applications.

- Connect anti-surge elements to all inductive devices not controlled by S7-300 modules.
- For cabinet or cubicle lighting in the immediate range of your controller, use incandescent lamps or interference suppressed fluorescent lamps.

#### See also

How to protect digital output modules against inductive surge voltage (Page 267)

### A.2.2.5 5. Basic rule for ensuring EMC

#### Rule 5: Homogeneous reference potential

Create a homogeneous reference potential and ground electrical equipment whenever possible (refer to the section on Equipotential bonding).

- Route your equipotential conductors over a wide area if potential differences exist or are expected between your system components.
- Make sure you carefully direct your grounding measures. Grounding measures protect the controller and its functions.
- Form a star circuit to connect the equipment in your system and the cabinets containing central/expansion units to the grounding/protective conductor system. This prevents the formation of ground loops.

#### See also

Equipotential bonding (Page 254)

## A.2.3 EMC-compliant installation of automation systems

### Introduction

Quite often it is the case that interference suppression measures are not taken until corruption of user signals is detected after the controller is actually in operation.

Frequently, the causes of such interference are found in inadequate reference potentials as a result of faulty installation. This section shows you how to avoid such errors.

### Inactive metal parts

Inactive parts are referred to as electrically conductive elements, separated from active elements by a basic insulating and only subject to electrical potential if an error occurs.

### Installation and ground bonding of inactive metal parts

Bond all inactive metal parts to a large-surface ground when you install the S7-300. Proper ground bonding ensures a homogeneous reference potential for the controller and reduces the effect of interference coupling.

The ground connection establishes an electrically conductive interconnection of all inactive parts. The sum of all interconnected inactive parts is referred to as chassis ground.

This chassis ground must never develop a hazardous potential even if a fault occurs. Therefore, chassis ground must be connected to the protective conductor using cables with an adequate conductor cross-section. To avoid ground loops, physically separate chassis ground elements (cabinets, parts of the building construction or machine) must be bonded to the protective conductor system in a star circuit.

**Observe the following for ground connection:**

- In the same way as with active elements, exercise meticulous care to interconnect inactive metal elements.
- Always make sure that you have a low-impedance interconnection between metal elements (e.g. large and highly conductive contact surface).
- The protective insulating finish on varnished or anodized metal elements must be pierced or removed. Use special contact washers or completely remove the finish on the point of contact.
- Protect your connecting elements against corrosion (e.g. with a suitable grease).
- Interconnect moving chassis ground elements (e.g. cabinet doors) with flexible ground straps. Always use short ground straps with a large surface (the surface is decisive for the diversion of high-frequency currents).



## A.2.4 Examples of an EMC-compliant installation: Cabinet configuration

### Cabinet configuration

The figure below shows a cabinet installation with the measures described above (bonding of inactive metal parts to chassis ground and connecting the cable shielding to ground). This sample applies only to grounded operation. Note the points in the figure when you install your system.

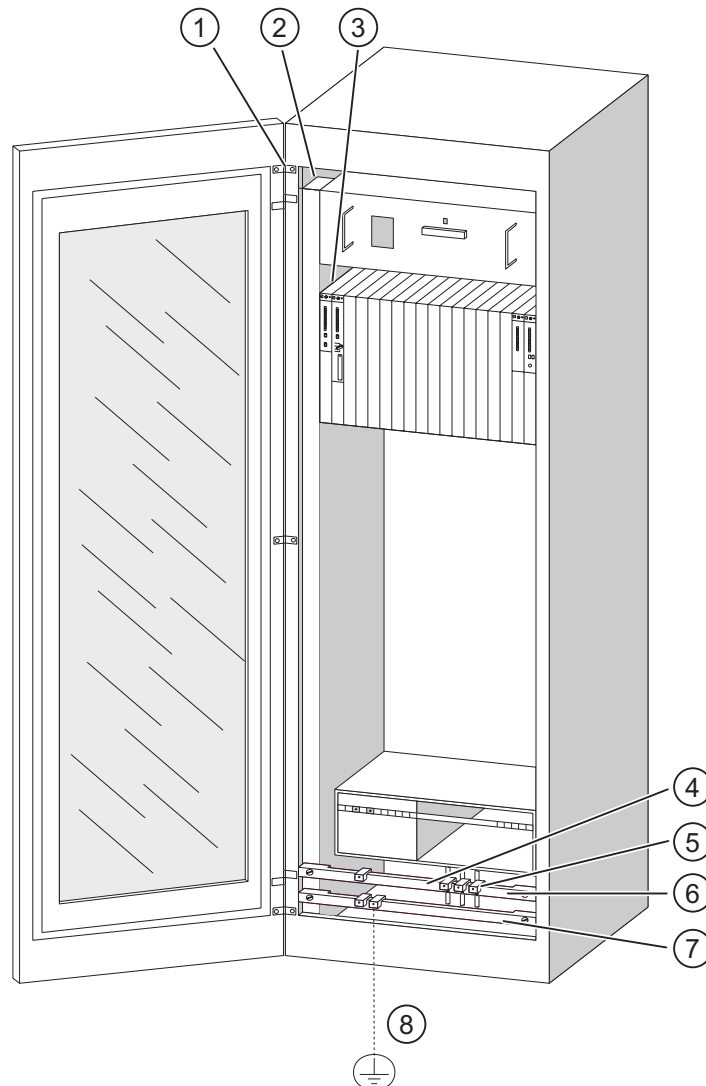

Figure A-1 Example of an EMC compatible cabinet installation

## Key to installation

The numbers in the following list refer to the numbers in the figure above.

Number	Identifier	Explanation
①	Ground straps	If no large-surface metal-to-metal connections are available, you must either interconnect inactive metal parts (e.g. cabinet doors or mounting plates) or bond them to chassis ground using ground straps. Use short ground straps with a large surface.
②	Supporting bars	Interconnect the supporting bars on a large area to the cabinet walls (metal-to-metal connection).
③	Mounting the rail	The mounting bar and rack must be interconnected with large-area metal-to-metal connections.
④	Signal cables	Connect the shielding of signal cables on a large area of the protective conductor/additional shielding conductor bar and fasten them with cable clamps.
⑤	Cable clamp	The cable clamp must cover a large area of the shielding braid and ensure good contact.
⑥	Shielding conductor bar	Interconnect the shielding conductor bar on a large surface with the supporting bars (metal-to-metal connection). The cable shielding is terminated on the conductor bar.
⑦	Protective ground bar	Interconnect the protective conductor bar on a large surface with the supporting bars (metal-to-metal connection). Interconnect the grounding busbar with the protective ground system, using a separate cable (minimum cross-section 10 <sup>2</sup> ).
⑧	Cable to the protective ground system (equipotential ground)	Interconnect the cable on a large area with the protective ground system (equipotential ground).

## A.2.5 Examples of an EMC-compliant installation: Wall mounting

### Wall mounting

When operating your S7 in a low-noise environment that conform with permitted ambient conditions (see Appendix Ambient conditions), you can also mount your S7 in frames or to the wall.

Interference coupling must be diverted to large metal surfaces. Therefore, always mount standard profile/shielding/protective conductor rails on metal parts of the construction. Steel sheet panels reference potential surfaces have been found especially suitable for wall-mounting.

Provide a shielding conductor bar for connecting your cable shielding. This shielding conductor bar can also be used as protective ground bar.

### Reference for ambient conditions

For information on ambient conditions, refer to the *S7-300 Automation System, Module data Reference Manual*.

**Please note**

- When mounting on varnished or anodized metal parts, use special contact washers or remove the insulating layers.
- Provide a large-surface and low-impedance metal-to-metal connection for fastening the shielding/protective ground bar.
- Always touch-protect live mains conductors.

The figure below shows an example of EMC compatible wall-mounting of an S7.

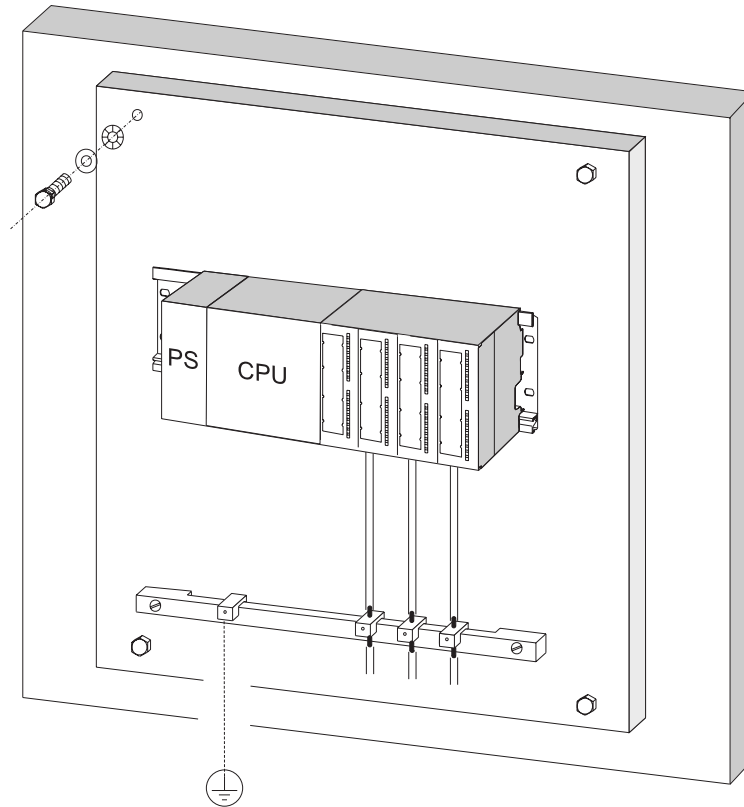

## A.2.6 Cable shielding

### Purpose of the shielding

A cable is shielded to attenuate the effects of magnetic, electrical and electromagnetic interference on the cable.

### Operating principle

Interference currents on cable shielding is diverted to ground conductive interconnection between the shielding and the cabinet. To avoid interference as a result of these currents, it is imperative to provide a low-impedance connection to the protective conductor.

### Suitable cables

Whenever possible, use cables equipped with a shielding braid. Shielding density should be at least 80%. Avoid cables with film shielding, because the film can be easily damaged by tensile or pressure stress, thus reducing its shielding effect.

## Handling of the shielding

Note the following points on handling the shielding:

- Always use metal clamps to mount shielding braid. The clamps must contact a large area of the shielding and provide appropriate contact force.
- Directly behind the cabinet's cable entry, terminate the shielding on a shielding bus. Then, route the cable to the module; however, do not connect the shielding once again to ground in this place.
- In installations outside of cabinets (e.g. for wall-mounting) you can also terminate the shielding on a cable duct.

The figure below shows some options for mounting shielded cables, using cable clamps.

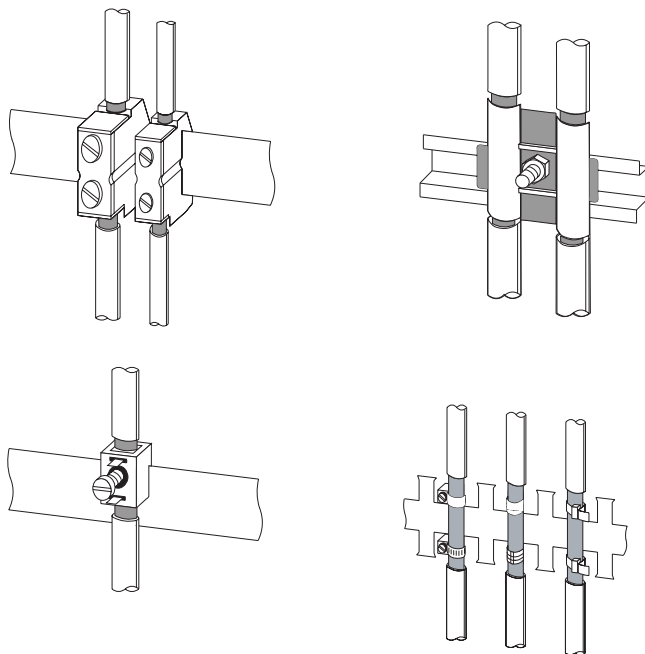

## See also

Terminating shielded cables on the shielding contact element (Page 114)

## A.2.7 Equipotential bonding

### Potential differences

Potential differences can occur between separate system elements. This can result in high equipotential currents, e.g. if the cable shielding is terminated at both ends and grounded to different system components.

The cause of potential difference can be differences in the power supplies.

 <b>WARNING</b>
--

Cable shielding is not suitable for equipotential bonding. Always use the prescribed cables (e.g. with a cross-section of 16 mm <sup>2</sup> ). When installing MPI/DP networks, provide a sufficient conductor cross-section. Otherwise, interface hardware might get damaged or even be destroyed.
--

### Equipotential bonding conductor

To reduce potential differences and ensure proper functioning of your electronic equipment, you must install equipotential bonding conductors.

Note the following points on the use of equipotential bonding conductors:

- The lower the impedance of an equipotential bonding conductor, the more effective is equipotential bonding.
- When shielded signal cables interconnect two system components and the shielding is connected on both ends to ground/protective conductors, the impedance of the additional equipotential bonding conductor must not exceed 10% of the shielding impedance.
- Determine the cross-section of your equipotential bonding conductor on the basis of the maximum equalizing current that will flow through it. The equipotential bonding conductor cross-section that has proven best in practice is 16 mm<sup>2</sup>.
- Always use equipotential bonding conductors made of copper or galvanized steel. Always connect the cables on a large surface to the equipotential conductor bar/protective conductor and protect it against corrosion.

- Route your equipotential bonding conductor to minimize the area between the equipotential bonding conductor and signal lines as far as possible (see the figure below).

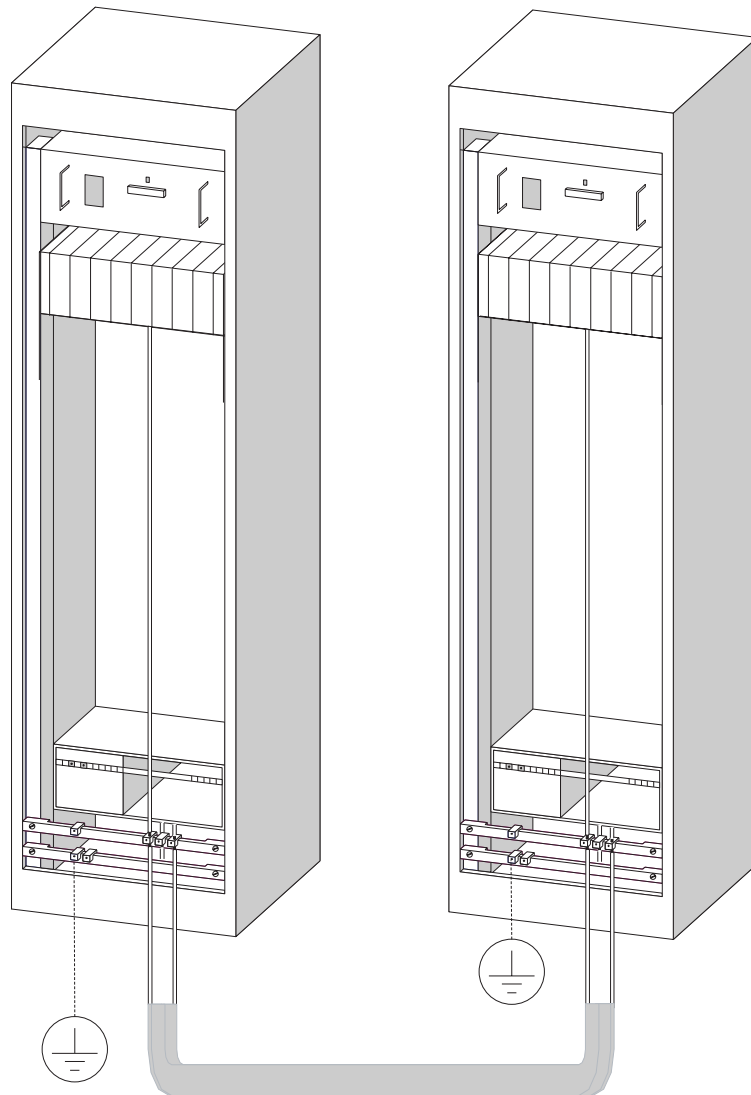

## A.2.8 Cable routing inside buildings

### Introduction

Inside buildings (inside and outside cabinets), clearances must be maintained between groups of different cables to achieve the necessary electromagnetic compatibility (EMC). The table contains information on the general rules governing clearances to enable you to choose the right cables.

### How to read the table

To find out how to run two cables of different types, proceed as follows:

1. Look up the type of the first cable in column 1 (Cables for ...).
2. Look up the type of the second cable in the corresponding field in column 2 (and cables for ...).
3. Note the applicable directives in column 3 (Run ...).

Table A- 6 Cable routing inside buildings

Cables for ...	and cables for ...	Run ...
<ul style="list-style-type: none"> <li>• Bus signals, shielded (PROFIBUS)</li> <li>• Data signals, shielded (programming devices, operator panels, printers, counter inputs, etc.)</li> <li>• Analog signals, shielded</li> <li>• DC voltage (<math>\leq 60</math> V), unshielded</li> <li>• Process signals (<math>\leq 25</math> V), shielded</li> <li>• AC voltage (<math>\leq 25</math> V), unshielded</li> <li>• Monitors (coaxial cable)</li> </ul>	<ul style="list-style-type: none"> <li>• Bus signals, shielded (PROFIBUS)</li> <li>• Data signals, shielded (programming devices, operator panels, printers, counter inputs, etc.)</li> <li>• Analog signals, shielded</li> <li>• DC voltage (<math>\leq 60</math> V), unshielded</li> <li>• Process signals (<math>\leq 25</math> V), shielded</li> <li>• AC voltage (<math>\leq 25</math> V), unshielded</li> <li>• Monitors (coaxial cable)</li> </ul>	In common bundles or cable ducts
	<ul style="list-style-type: none"> <li>• DC voltage (<math>&gt; 60</math> V and <math>\leq 400</math> V), unshielded</li> <li>• AC voltage (<math>&gt; 25</math> V and <math>\leq 400</math> V), unshielded</li> </ul>	In separate bundles or cable ducts (no minimum clearance necessary)
	<ul style="list-style-type: none"> <li>• DC and AC voltage (<math>&gt; 400</math> V), unshielded</li> </ul>	<p><b>Inside cabinets:</b> In separate bundles or cable ducts (no minimum clearance necessary)</p> <p><b>Outside cabinets:</b> On separate cable racks with a clearance of at least 10 cm</p>



Cables for ...	and cables for ...	Run ...
<ul style="list-style-type: none"> <li>DC voltage (&gt; 60 V and ≤ 400 V), unshielded</li> <li>AC voltage (&gt; 25 V and ≤ 400 V), unshielded</li> </ul>	<ul style="list-style-type: none"> <li>Bus signals, shielded (PROFIBUS)</li> <li>Data signals, shielded (programming devices, operator panels, printers, counter inputs, etc.)</li> <li>Analog signals, shielded</li> <li>DC voltage (≤ 60 V), unshielded</li> <li>Process signals (≤ 25 V), shielded</li> <li>AC voltage (≤ 25 V), unshielded</li> <li>Monitors (coaxial cable)</li> </ul>	In separate bundles or cable ducts (no minimum clearance necessary)
	<ul style="list-style-type: none"> <li>DC voltage (&gt; 60 V and ≤ 400 V), unshielded</li> <li>AC voltage (&gt; 25 V and ≤ 400 V), unshielded</li> </ul>	In common bundles or cable ducts
	<ul style="list-style-type: none"> <li>DC and AC voltage (&gt; 400 V), unshielded</li> </ul>	<p><b>Inside cabinets:</b></p> <p>In separate bundles or cable ducts (no minimum clearance necessary)</p> <p><b>Outside cabinets:</b></p> <p>On separate cable racks with a clearance of at least 10 cm</p>
DC and AC voltage (> 400 V), unshielded	<ul style="list-style-type: none"> <li>Bus signals, shielded (PROFIBUS)</li> <li>Data signals, shielded (programming devices, operator panels, printers, counter inputs, etc.)</li> <li>Analog signals, shielded</li> <li>DC voltage (≤ 60 V), unshielded</li> <li>Process signals (≤ 25 V), shielded</li> <li>AC voltage (≤ 25 V), unshielded</li> <li>Monitors (coaxial cable)</li> </ul>	<p><b>Inside cabinets:</b></p> <p>In separate bundles or cable ducts (no minimum clearance necessary)</p> <p><b>Outside cabinets:</b></p> <p>On separate cable racks with a clearance of at least 10 cm</p>
	<ul style="list-style-type: none"> <li>DC and AC voltage (&gt; 400 V), unshielded</li> </ul>	In common bundles or cable ducts
ETHERNET	ETHERNET	In common bundles or cable ducts
	Others	In separate bundles or cable ducts with a clearance of at least 50 cm

## A.2.9 Outdoor routing of cables

### Rules for EMC-compliant cable routing

The same EMC-compliant rules apply both to indoor and outdoor routing of cables. The following also applies:

- Running cables on metal cable trays.
- Electrical connection of the joints of cable trays/ducts.
- Ground the cable carriers.
- If necessary, provide adequate equipotential bonding between connected devices.
- Take the necessary (internal and external) lightning protection and grounding measures in as far as they are applicable to your particular application.

### Rules for lightning protection outside buildings

Run your cables either:

- in metal conduits grounded at both ends, or
- in concrete cable ducts with continuous end-to-end armoring.

### Overvoltage protection equipment

An individual appraisal of the entire plant is necessary before any lightning protection measures are taken.

## A.3 Lightning and surge voltage protection

### A.3.1 Overview

We show you solutions for the protection of your S7-300 against damage as a result of surge voltage.

Failures are very often the result of surge voltage caused by:

- Atmospheric discharge or
- Electrostatic discharge.

We will begin by showing you what the theory of surge protection is based on: the lightning protection zone concept

At the end of this section, you will find rules for the transition points between individual lightning protection zones.

---

#### Note

This section can only provide information on the protection of a PLC against surge voltage. However, complete surge protection is guaranteed only if the whole surrounding building is designed to provide protection against overvoltage. This applies especially to constructional measures for the building at the planning stage.

If you wish to obtain detailed information on surge protection, we therefore recommend you contact your Siemens partner or a company specialized in lightning protection.

---

### A.3.2 Lightning protection zone concept

#### Principle of the lightning protection zone concept to DIN EN 62305-4 (VDE 0185-305-4)

The principle of the lightning protection zone concept states that the volume to be protected against overvoltage, for example, a manufacturing hall, is subdivided into lightning protection zones in accordance with EMC directives (see Figure ).

The various lightning protection zones (LPZ: Lightning Protection Zone) are formed by:

Lightning protection of the building exterior (field side)	Lightning Protection Zone 0
Shielding	
• Buildings	Lightning Protection Zone 1
• Rooms and/or	Lightning Protection Zone 2
• Devices	Lightning Protection Zone 3

### Effects of the Lightning Strike

Direct lightning strikes occur in lightning protection zone 0. Lightning strike generates high-energy electromagnetic fields which can be reduced or eliminated from one lightning protection zone to the next by suitable lightning protection elements/measures.

### Overvoltage

In lightning protection zones 1 and higher, a lightning strike might additionally cause overvoltage as a result of switching operations, coupling etc.

### Scheme of the lightning protection zones of a building

The figure below shows a block diagram of the lightning protection zone concept for a detached building.

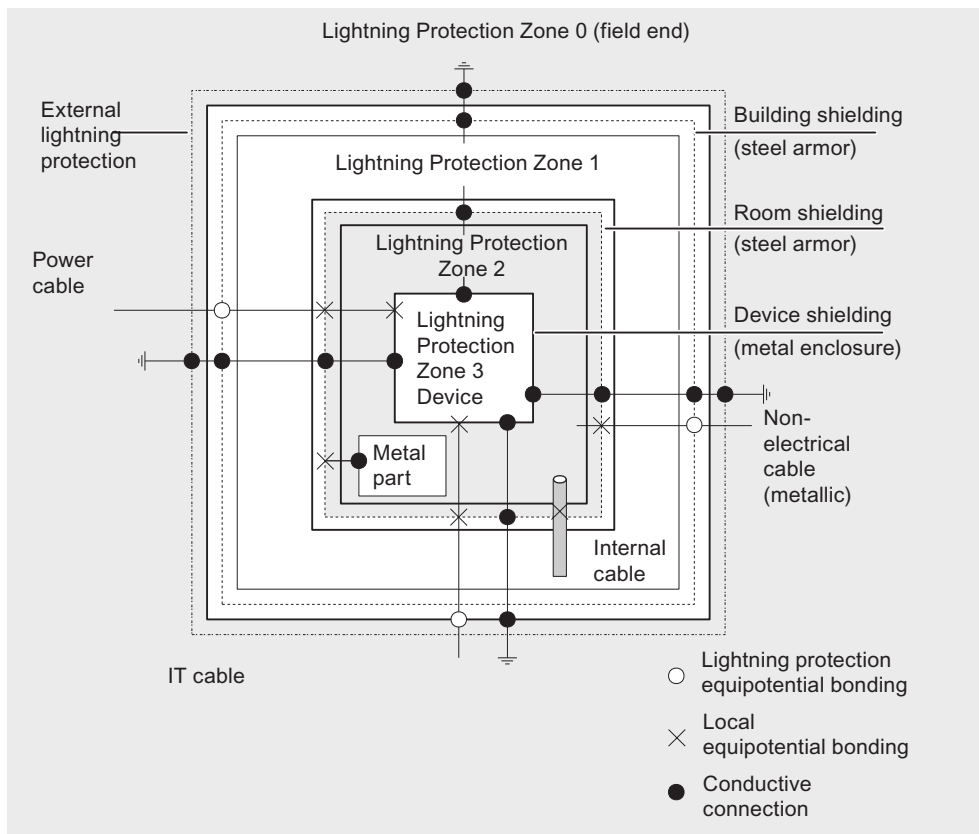

### Principle of the transition points between lightning protection zones

At the transition points between lightning protection zones, you must take measures to prevent surges being conducted downstream.

The principle of a lightning protection zone also requires that at the transition points between the lightning protection zones, all cables and piping capable of carrying lightning current (!) must be included in the equipotential bonding system.

Metallic lines include:

- the piping (for example, of water, gas and heat)
- Power cables (for example, mains voltage, 24 V supply)
- Data cables (for example, bus cable).

### A.3.3 Rules for the transition point between lightning protection zones 0 <-> 1

#### Rules for transition point 0 <-> 1 (lightning protection equipotential bonding)

The following measures are suitable for lightning protection equipotential bonding at the transition between lightning protection zones 0 <-> 1:

- Use grounded, spiraled, current-conducting metal straps or metal braiding as a cable shield at both ends, for example, NYCY or A2Y(K)Y.
- Install cables in one of the following media:
  - in continuous metal pipes that are grounded at both ends, or
  - in continuously armored concrete ducts or
  - on closed metal cable trays grounded at both ends.
  - use fiber-optic cables instead of metal conductors.

#### Additional measures

If you cannot take measures as described above, you must install a lightning conductor (Type 1) at the 0 <-> 1 transition point. The table below contains the components you can use for the so-called lightning protection equipotential bonding (0->1) of your plant.

Table A- 7 Lightning conductor (Type 1) of cables with the help of surge protection equipment

Seq. No.	Cables for ...	... at transition point 0 <-> 1 install:		Order no. without FM*	Order no. with FM*
1	3-phase TN-C system	1 piece	DEHNbloc DV TNC 255 phase L1/L2/L3 to PEN	951 300	951 305
	3-phase TN-S system	1 piece	DEHNbloc DV M 255 (FM) phase L1/L2/L3 to PE	951 400	951 405
	3-phase TT system	1 piece	DEHNbloc DV M TT 255 (FM) phase L1/L2/L3 to N	951 310	951 315
	AC TN system	1 piece	DEHNbloc DV M TN 255 (FM) phase L1 + N to PE	951 200	951 205
	AC TT system	1 piece	DEHNbloc DV M TT 2P 255 (FM) phase to N and PE	951 110	951 115

Seq. No.	Cables for ...	... at transition point 0 <-> 1 install:		Order no. without FM*	Order no. with FM*
2	24 VDC power supply	1 piece	Blitzductor VT Type AD 24 V -	918 402	-
3	MPI bus cable, RS485, RS232 (V.24)	1 piece	Surge arresters Blitzductor XT Type BXT ML4 B 180	920 300 and 920 310	-
4	Inputs/outputs of 24 V digital modules		DEHNrail DR M 2P	953 206	-
5	Inputs/outputs of digital modules and 120/230 VAC power supply	2 pieces	Lightning current arrester DEHNbloc Maxi DBM 1 255 L	900 026	-
6	Inputs/outputs of analog modules up to 12 V +/-	1 piece	Surge arresters Blitzductor XT Type BXT ML4 B 180	920 300 and 920 310	-

\* You can order these components directly from:  
 DEHN + SÖHNE GmbH + Co. KG  
 Hans-Dehn-Str. 1  
 92318 Neumarkt  
 Germany

### A.3.4 Rules for the transition point between lightning protection zones 1 <-> 2 and higher

#### Rules for 1 <-> 2 transition points and higher (local equipotential bonding)

The following measures must be taken on all transition points 1 <-> 2 and higher:

- Set up local equipotential bonding at each subsequent lightning protection zone transition points.
- Include all lines (also metal conduits, for example) in the local equipotential bonding of all subsequent lightning protection zone transition points.
- Include all metal installations located within the lightning protection zone in the local equipotential bonding (for example, metal part within lightning protection zone 2 at transition 1 <-> 2).

#### Additional measures

We recommend fine-wire fusing for following elements:

- All 1 <-> 2 and greater lightning protection zone transitions
- All cables that run within a lightning protection zone and are longer than 100 m

#### Lightning protection element for the 24 VDC power supply module.

Always use the Blitzductor VT, type AD 24 V SIMATIC for the 24 VDC power supply module of the S7-300. All other surge protection components do not meet the required tolerance range of 20.4 V to 28.8 V of the S7-300 power supply.

## Lightning Conductor for Signal Modules

You can use standard surge protection components for the digital I/O modules. However, please note that these only permit a maximum of 26.8 V for a rated voltage of 24 VDC. If the tolerance of your 24 VDC power supply is higher, use surge protection components with 30 VDC rating.

You can also use Blitzductor VT, type AD 24 V. Note that input current can increase if negative input voltages are generated.

## Low-voltage protection elements for 1 <-> 2

For the transition points between lightning protection zones 1 <-> 2 we recommend the surge protection components listed in the table below. This low-voltage protection must be used in S7-300 for CE compliance.

Table A- 8 Surge-protection components for lightning protection zones 1 <-> 2

Seq. No.	Cables for ...	... equip transition point 1 <-> 2 with:		Order no. without FM*	Order no. with FM*
1	3-phase TN-C system	1 piece	Surge arrester DG M TNC 275	952 300	952 305
	3-phase TN-S system	1 piece	Surge arrester DG M TNS 275	952 400	952 405
	3-phase TT system	1 piece	Surge arrester DG M TT 275	952 310	952 315
	AC TN system	1 piece	Surge arrester DG M TN 275	952 200	952 205
	AC TT system	1 piece	Surge arrester DG M TT 2P 275	952 110	952 115
2	24 VDC power supply	1 piece	Blitzductor VT, Type AD 24 V	918 402	-
3	Bus cable				
	• MPI/DP RS485		• Blitzductor BCT MOD MD HFD 5	919 506 and 919 571	-
	• RS232 (V.24)	1 piece	• Combination arrester Blitzductor XT type BTX ML4 BE12	920 300 and 920 322	-
	• Industrial Ethernet	1 piece	• DEHN Patch	929 100	-
4	Inputs of digital modules DC 24 V	1 piece	Suppressor circuit Type DCO RK E 24	919 988	-
5	Outputs of digital modules 24 V	1 piece	Low-voltage protection type DCO RK D 5 24	919 986	-
6	Inputs/outputs of digital modules	2 pieces	Surge arrester		-
	• 120 VAC		• DEHNguard S 150	952 072	952 092
	• 230 VAC		• DEHNguard S 275	952 070	952 090
7	Inputs of analog modules up to 12 V +/-	1 piece	Combination arrester Blitzductor XT type BXT ML4 BD12	920 300 and 920 342	-

\* Please order these components directly from:

DEHN + SÖHNE GmbH + Co. KG  
Hans-Dehn-Str. 1  
92318 Neumarkt  
Germany

**Low-voltage protection elements for 2 <-> 3**

For the transition points between lightning protection zones 2 <-> 3 we recommend the surge protection components listed in the table below. This low-voltage protection must be used in S7-300 for CE compliance.

Table A-9 Surge-protection components for lightning protection zones 2 &lt;-&gt; 3

Seq. No.	Cables for ...	... equip transition point 2 <-> 3 with:		Order No.
1	3-phase TN-C system	1 piece	Surge arrester DG M TNC 275 FM	952 305
	3-phase TN-S system	1 piece	Surge arrester DG M TNS 275 FM	952 405
	3-phase TT system	1 piece	Surge arrester DG M TT 275 FM	952 315
	AC TN system	2 pieces	Surge arrester DG M TN 275 FM	952 205
	AC TT system	1 piece	Surge arrester DG M TT 2P 275 FM	952 115
2	24 VDC power supply	1 piece	Blitzductor VT, Type AD 24 V	918 402*
3	Bus cable			
	• MPI, RS485		Blitzductor BCT MOD MD HFD 5	919 506* and 919 571*
	• RS232 (V.24)	1 piece	• Per cable pair suppressor circuit DCO RK E 12	919 987
4	Inputs of digital modules			
	• 24 VDC	1 piece	Low-voltage surge protection Type DCO RK E 24, on insulated rail	919 988*
		2 pieces	Surge arrester	
	• 120 VAC		• DEHNrail M 2P 150 FM	953 209*
	• 230 VAC		• DEHNrail M 2P 255 FM	953 205*
5	Outputs of digital modules 24 V	1 piece	Low-voltage protection DCO RK D 5 24	919 986
6	Outputs of analog modules up to 12 V +/-	1 piece	Low-voltage surge protection Type DCO RK E 12, on insulated rail connected with M- of the power supply for the modules.	919 987*

\* Please order these components directly from:  
 DEHN + SÖHNE GmbH + Co. KG  
 Hans-Dehn-Str. 1  
 92318 Neumarkt  
 Germany



### A.3.5 Example: Surge protection circuit for networked S7-300 PLCs

The sample in the figure below shows you how install an effective surge protection for two networked S7-300 PLCs:

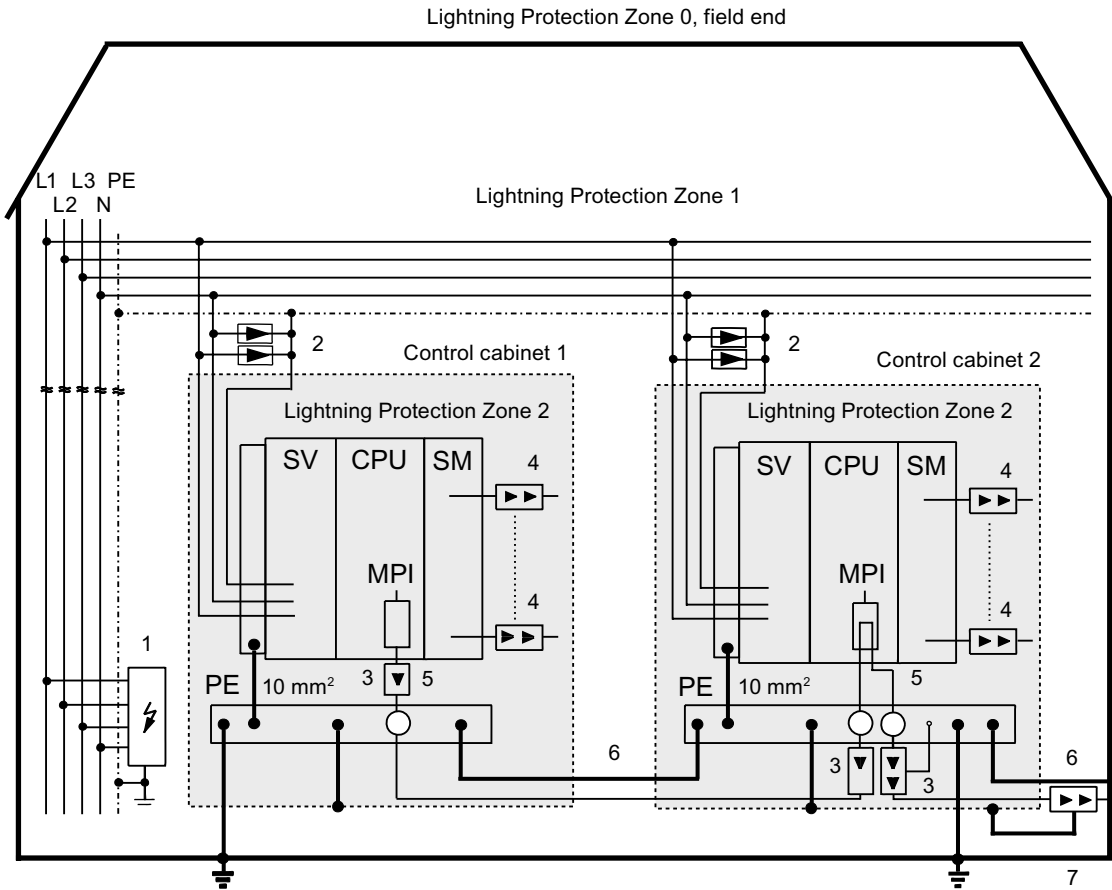

**Key**

The table below explains consecutive numbers in the figure above:

Table A- 10 Example of a circuit conforming to lightning protection requirements (legend to previous figure)

Seq. No.	Component	Meaning
1	Lightning arrester, depending on the mains system, for example, a TN-S system: 1 item DEHNbloc DV M TNS 255 (FM) Order no. without FM: 951 400* Order no. with FM: 951 405*	Protection against direct lightning strike and surge voltage as of transition 0 <-> 1
2	Surge arresters, 2 items DEHNguard DG M TN 275 FM Order no.: 952 205*	Surge protection at transition 1 <-> 2
3	Surge arrester, Blitzductor BCT MOD MD HFD 5 Order no.: 919 506* and 919 571*	Surge protection for RS485 interfaces at transition 1 <-> 2
4	Digital input modules: DCO RK E 24 Order no.: 919 988 Digital output modules: DCO RK D 5 24 Order no.: 919 986 Analog modules: Blitzductor XT, Order no.: 920 300 and 920 342	Surge protection of signal module I/O at transition 1 <-> 2
5	Bus cable shielding mounting device with EMC spring clamp on the basic unit of Blitzductor CT, order no.: 919 508*	Discharge of interference current
6	Cable for equipotential bonding: 16 mm	Standardization of reference potentials
7	Blitzductor XT for building transitions; Order no.: 920 300* and 920 310*	High-voltage surge protection for RS485 interfaces at transition 0 <->1

\* Please order these components directly from:  
DEHN + SÖHNE GmbH + Co. KG  
Hans-Dehn-Str. 1  
92318 Neumarkt  
Germany

## A.3.6 How to protect digital output modules against inductive surge voltage

### Inductive surge voltage

Overvoltage occurs when inductive devices are switched off. Examples are relay coils and contactors.

### Integrated surge arrester

S7-300 digital output modules are equipped with an integrated surge arrester.

### Additional overvoltage protection

Inductive devices require additional surge arresters only in following cases:

- If SIMATIC output circuits can be switched off by additionally installed contacts (e.g. relay contacts).
- If the inductive loads are not controlled by SIMATIC modules

Note: Request information on relevant surge protection rating from the supplier of inductive devices.

### Example: EMERGENCY-OFF relay contact in the output circuit

The figures illustrates an output circuit requiring additional overvoltage protectors.

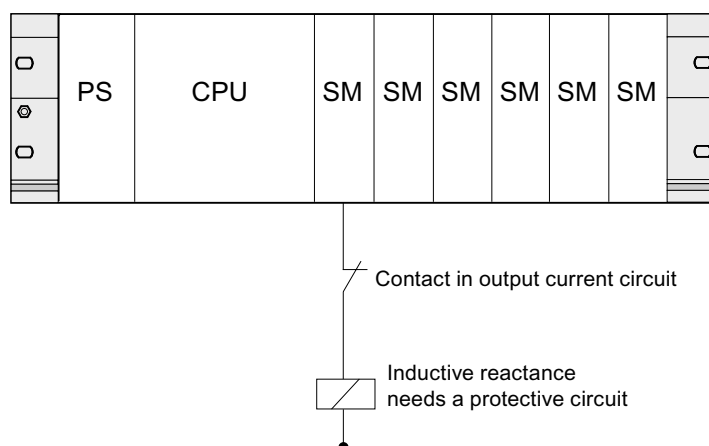

Refer also to the rest of the information in this section.

### Circuit for coils operated with DC voltage

The figure below shows DC-operated coils equipped with diode or Zener diode circuit.

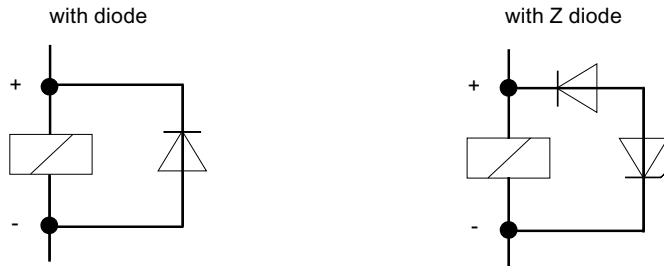

Diode/Zener diode circuits have the following characteristics:

- Opening surge voltage can be totally avoided.  
The Zener diode has a higher switch-off voltage capacity.
- High switch-off delay (6 to 9 times higher than without protective circuit).  
The Zener diode switches off faster than a diode circuit.

### Circuit for coils operated with AC voltage

The figure shows coils operated with AC voltage and varistor or RC circuit.



The characteristics of varistor circuits are:

- The amplitude of the opening surge is limited rather than attenuated.
- The surge rise-ratio remains the same.
- Short off-delay.

The characteristics of RC circuits are:

- Amplitude and steepness of the opening surge are reduced.
- Short off-delay.

## A.4 Functional safety of electronic control equipment

### Reliability through basic measures

SIMATIC devices and components are extremely reliable thanks to extensive measures in development and production.

The basic measures include:

- Selection of high-quality components and strategic cooperation with high-performance suppliers
- Measures to prevent static discharge when handling MOS circuits
- Checks and monitoring of the production processes using statistical methods and visual inspections at various production stages
- Heat endurance run at higher ambient temperature as monitoring run-in
- Thorough computer-controlled final inspection and testing of all modules.
- Statistical evaluation of all returned systems and components and analysis of service requests to enable the immediate initiation of suitable corrective measures
- Comprehensive computer-aided acquisition of the quality data in the production in order to ensure all the adopted measures

### Increased safety measures

In all cases where the occurrence of failures can result in material damage or injury to persons, special measures must be taken to enhance the safety of the entire installation. For these there exist special plant-specific regulations that also have to be taken into consideration by the owner-operator when structuring the control system.

For electronic control equipment with a safety function, the measures that have to be taken to prevent or rectify faults are based on the risks involved in the installation. As of a certain degree of hazard the basic measures mentioned above are no longer sufficient. The owner-operator has to ensure that additional measures are realized for the plant, for example by using SIMATIC S7-F fail-safe control systems.

### Important note

The instructions in the operating manual must be followed exactly. Incorrect handling can render measures intended to prevent dangerous faults ineffective, or generate additional sources of danger.

### Fail-safe systems in SIMATIC S7

Two fail-safe systems are available for the integration of the safety technology in the SIMATIC S7 automation systems:

- The fail-safe *S7 Distributed Safety* automation system
  - For the implementation of safety concepts in the field of machine and person protection, for example EMERGENCY-OFF facilities for the operation of machine tools/processing machines.
  - In the process industry, for example for carrying out protection functions for instrumentation-and-control protective systems and burners.
- The fail-safe and optionally fault-tolerant *S7 F/FH Systems* automation system for plants for example in process technology and the oil industry.

### Fail-safe and redundant system *S7 F/FH system*

To increase the availability of the automation system and thereby avoid process interruption in the case of errors, it is possible to build in fail-safe systems as optionally redundant *S7 F/FH systems*. The increased availability is achieved through the redundancy of the following components: Power supply, CPU module, communications and IO devices.

### Attainable safety requirements

S7 Distributed Safety F systems and S7 F/FH systems can meet the following safety requirements:

- Safety Integrity Level SIL1 to SIL3 to IEC 61508
- Categories 2 to 4 according to EN 954-1.

### Reference

You can find further information in the *Safety Engineering in SIMATIC S7* system description (A5E00109528-05).

# Glossary

## Accumulator

Accumulators represent CPU register and are used as buffer memory for download, transfer, comparison, calculation and conversion operations.

## Address

An address is the identifier of a specific address or address area. Examples: Input I 12.1; Flag Word MW 25; Data Block DB 3.

## Analog module

Analog modules convert process values (e.g. temperature) into digital values which can be processing in the CPU, or they convert digital values into analog manipulated variables.

## Application

→ *User program*

## Application

An application is a program that runs directly on the MS-DOS / Windows operating system. Applications on the programming device are for example STEP 7.

## ASIC

ASIC is the acronym for Application Specific Integrated Circuits.

PROFINET ASICs are components with a wide range of functions for the development of your own devices. They implement the requirements of the PROFINET standard in a circuit and allow extremely high packing densities and performance.

Because PROFINET is an open standard, SIMATIC NET offers PROFINET ASICs for the development of your old devices under the name ERTEC .

## Backplane bus

The backplane bus is a serial data bus. It supplies power to the modules and is also used by the modules to communicate with each other. Bus connectors interconnect the modules.

## Backup memory

Backup memory ensures buffering of the memory areas of a CPU without backup battery. It backs up a configurable number of timers, counters, flag bits, data bytes and retentive timers, counters, flag bits and data bytes).

### Bit memory

Flag bits are part of the CPU's system memory. They store intermediate results of calculations. They can be accessed in bit, word or dword operations.

*See System memory*

### Bus

A bus is a communication medium connecting several nodes. Data can be transferred via serial or parallel circuits, that is, via electrical conductors or fiber optic.

### Bus segment

A bus segment is a self-contained section of a serial bus system. Bus segments are interconnected by way of repeaters, for example, in PROFIBUS DP.

### Central module

→ *CPU*

### Changing IO devices during operation (changing partner ports)

Functionality of a PROFINET device. A PROFINET device that supports this function can communicate during operation with changing communication partners at the same port.

### Clock flag bits

flag bit which can be used to generate clock pulses in the user program (1 byte per flag bit).

---

#### Note

When operating with S7-300 CPUs, make sure that the byte of the clock memory bit is not overwritten in the user program!

---

### Coaxial cable

A coaxial cable, also known as "coax", is a metal conductor system used in HF transmission circuits, for example, as radio and TV antenna cable, and in modern networks demanding high data transmission rates. The inner conductor of a coaxial cable is sheathed by a tube-like outer conductor. These conductors are separated by plastic insulation. In contrast to other cables, this type of cable provides a high degree of immunity to interference and EMC compatibility.



**Code block**

A SIMATIC S7 code block contains part of the **STEP 7** user program. (in contrast to a DB: this contains only data.)

**Code block**

→ *Global data*

**Code block**

→ *Nesting depth*

**Communication processor**

Communication processors are modules used for point-to-point and bus topologies.

**Component Based Automation**

→ *PROFINET CBA*

**Compress**

The PG online function "Compress" is used to rearrange all valid blocks in CPU RAM in a contiguous area of load memory, starting at the lowest address. This eliminates fragmentation which occurs when blocks are deleted or edited.

**Configuration**

Assignment of modules to module racks/slots and (e.g. for signal modules) addresses.

**Consistent data**

Data which belongs together in terms of content and must not be separated is known as consistent data.

For example, the values of analog modules must always be handled as a whole, that is, the value of an analog module must not be corrupted as a result of read access at two different points of time.

**Counter**

Counters are part of CPU system memory. The content of "Counter cells" can be modified by **STEP 7** instructions (for example, up/down count.)

*See also System memory*

**CP**

→ *Communication processor*

## CPU

Central processing unit = CPU of the S7 automation system with a control and arithmetic unit, memory, operating system, and interface for programming device.

## Cycle time

The cycle time represents the time a CPU requires for one execution of the user program.

## Cyclic interrupt

→ *Interrupt, cyclic interrupt*

## Data block

Data blocks (DB) are data areas in the user program which contain user data. There are global data blocks which can be accessed by all code blocks, and instance data blocks which are assigned to a specific FB call.

## Data exchange broadcast

→ *Direct data exchange*

## Data exchange traffic

→ *Direct data exchange*

## Data set routing

Functionality of a module with several network connections. Modules that support this function are able to pass on data of an engineering system (for example parameter data generated by SIMATIC PDM) from a subnetwork such as Ethernet to a field device at the PROFIBUS DP.

## Data, static

Static data can only be used within a function block. These data are saved in an instance data block that belongs to a function block. Data stored in an instance data block are retained until the next function block call.

## Data, temporary

Temporary data represent local data of a block. They are stored in the L-stack when the block is executed. After the block has been processed, these data are no longer available.

## Default Router

The default router is the router that is used when data must be forwarded to a partner located within the same subnet.

In STEP 7, the default router is named *Router*. STEP 7 assigns the local IP address to the default router.

## Determinism

→ *Real Time*

## Device Name

Before an IO device can be addressed by an IO controller, it must have a device name. In PROFINET, this method was selected because it is simpler to work with names than with complex IP addresses.

The assignment of a device name for a concrete IO device can be compared with setting the PROFIBUS address of a DP slave.

When it ships, an IO device does not have a device name. An IO device can only be addressed by an IO controller, for example for the transfer of project engineering data (including the IP address) during startup or for user data exchange in cyclic operation, after it has been assigned a device name with the PG/PC .

## Device replacement without medium change

IO devices having this function can be replaced simply:

- A removable medium (such as Micro Memory Card) with the stored device name is not required.
- The device name does not have to be assigned using the programming device. The inserted IO device receives the device name from the IO controller, not from the removable medium or from the programming device. The IO controller uses the configured topology and the neighboring relationships determined by the IO devices to this purpose. The configured setpoint topology must agree with the actual topology.
- In case of a part being replaced, an IO device already in operation has to be reset to the state of delivery using "Reset to factory setting".

## Diagnostic interrupt

Modules capable of diagnostics operations report detected system errors to the CPU by means of diagnostic interrupts.

## Diagnostics

→ *System diagnostics*

### **Diagnostics buffer**

The diagnostics buffer represents a buffered memory area in the CPU. It stores diagnostic events in the order of their occurrence.

### **Direct data exchange**

Direct data exchange is a special communication relationship between PROFIBUS DP nodes. Direct data exchange is characterized by PROFIBUS DP nodes that "listen" on the bus and know which data a DP slave returns to its DP master.

### **DP master**

A master which behaves in accordance with EN 50170, Part 3 is known as a DP master.

### **DP slave**

A slave operated on PROFIBUS with PROFIBUS DP protocol and in accordance with EN 50170, Part 3 is referred to as DP slave.

### **DPV1**

The designation DPV1 means extension of the functionality of the acyclical services (to include new interrupts, for example) provided by the DP protocol. The DPV1 functionality has been incorporated into IEC 61158/EN 50170, volume 2, PROFIBUS.

### **Electrically isolated**

The reference potential of the control and on-load power circuits of isolated I/O modules is electrically isolated; for example, by optocouplers, relay contact or transformer. Input/output circuits may be grouped.

### **Equipotential bonding**

Electrical connection (equipotential bonding conductor) which eliminates potential difference between electrical equipment and external conductive bodies by drawing potential to the same or near the same level, in order to prevent disturbing or dangerous voltages between these bodies.

### **Error display**

One of the possible reactions of the operating system to a runtime error is to output an error message. Further reactions: Error reaction in the user program, CPU in STOP.

### **Error handling via OB**

After the operating system has detected a specific error (e.g. access error with **STEP 7**), it calls a dedicated block (Error OB) that determines further CPU actions.

**Error response**

Reaction to a runtime error. Reactions of the operating system: It sets the automation system to STOP, indicates the error, or calls an OB in which the user can program a reaction.

**ERTEC**

→ *ASIC*

**Fast Ethernet**

Fast Ethernet describes the standard with which data is transmitted at 100 Mbps. Fast Ethernet uses the 100 Base-T standard.

**FB**

→ *Function block*

**FC**

→ *Function*

**FEPRM**

→ *Memory Card (MC)*

**Flash EPROM**

FEPRMs can retain data in the event of power loss, same as electrically erasable EEPROMs. However, they can be erased within a considerably shorter time (FEPRM = Flash Erasable Programmable Read Only Memory). They are used on Memory Cards.

**Force**

The Force function can be used to assign the variables of a user program or CPU (also: inputs and outputs) constant values.

In this context, please note the limitations listed in the *Overview of the test functions section in the chapter entitled Test functions, Diagnostics and Troubleshooting in the S7-300 Installation manual.*

**Function**

According to IEC 1131-3, a function (FC) is a code block without static data. A function allows parameters to be passed in the user program. Functions are therefore suitable for programming frequently occurring complex functions, e.g. calculations.

### Function block

According to IEC 1131-3, a function block (FB) is a code block with static data. A function block allows parameters to be transferred to the user program. Function blocks are therefore suitable for programming frequently recurring, complex functions, e.g., closed-loop controls, mode selection.

### Functional ground

Grounding which has the sole purpose of safeguarding the intended function of electrical equipment. With functional grounding you short-circuit interference voltage which would otherwise have an unacceptable impact on equipment.

### GD circuit

A GD circuit comprises a number of CPUs sharing data by means of global data communication, and is used as follows:

- A CPU broadcasts a GD packet to the other CPUs.
- A CPU sends and receives a GD packet from another CPU.

A GD circuit is identified by a GD circuit number.

### GD element

A GD element is generated by assigning shared global data. It is identified by a unique global data ID in the global data table.

### GD packet

A GD packet can consist of one or several GD elements transmitted in a single message frame.

### Global data

Global data can be addressed from any code block (FC, FB, OB). In particular, this refers to flag bits M, inputs I, outputs Q, timers, counters and data blocks DB. Global data can be accessed via absolute or symbolic addressing.

### Global data communication

Global data communication is a method of transferring global data between CPUs (without CFBs).

**Ground**

The conductive earth whose electrical potential can be set equal to zero at any point.

Ground potential can be different from zero in the area of grounding electrodes. The term reference ground is frequently used to describe this situation.

**Ground**

The conductive earth whose electrical potential can be set equal to zero at any point.

Ground potential can be different from zero in the area of grounding electrodes. The term reference ground is frequently used to describe this situation.

**Ground**

The conductive earth whose electrical potential can be set equal to zero at any point.

Ground potential can be different from zero in the area of grounding electrodes. The term reference ground is frequently used to describe this situation.

**GSD file**

The properties of a PROFINET device are described in a GSD file (General Station Description) that contains all the information required for configuration.

As with PROFIBUS, you can link a PROFINET device in STEP 7 by means of a GSD file.

In PROFINET IO, the GSD file is in XML format. The structure of the GSD file conforms to ISO 15734, which is the world-wide standard for device descriptions.

In PROFIBUS, the GSD file is in ASCII format.

**HART**

English: **H**ighway **A**dressable **R**emote **T**ransducer

**Hub**

→ *Switch*

**Industrial Ethernet**

→ *Fast Ethernet*

**Industrial Ethernet**

Industrial Ethernet (formerly SINEC H1) is a technology that allows data to be transmitted free of interference in an industrial environment.

Due to the openness of PROFINET, you can use standard Ethernet components. We recommend, however, that you install PROFINET as Industrial Ethernet.

### Instance data block

The **STEP 7** user program assigns an automatically generated DB to every call of a function block. The instance data block stores the values of input, output and in/out parameters, as well as local block data.

### Interface, MPI-compatible

→ *MPI*

### Interrupt

The CPU's operating system distinguishes between different priority classes for user program execution. These priority classes include interrupts, e.g. process interrupts. When an interrupt is triggered, the operating system automatically calls an assigned OB. In this OB the user can program the desired response (e.g. in an FB).

### Interrupt, cyclic interrupt

A cyclic interrupt is generated periodically by the CPU in a configurable time pattern. A corresponding OB will be processed.

### Interrupt, delay

The delay interrupt belongs to one of the priority classes in SIMATIC S7 program processing. It is generated on expiration of a time started in the user program. A corresponding OB will be processed.

### Interrupt, delay

→ *Interrupt, delay*

### Interrupt, diagnostic

→ *Diagnostic interrupt*

### Interrupt, process

→ *Process interrupt*

### Interrupt, status

A status interrupt can be generated by a DPV1 slave or a PNIO device respectively. At the DPV1 master or the PNIO controller respectively the receipt of the interrupt causes the OB 55 to be called up.

For detailed information on OB 56, refer to the *Reference Manual System Software for S7-300/400: System and Standard Functions*.



### Interrupt, time-of-day

The time-of-day interrupt belongs to one of the priority classes in SIMATIC S7 program processing. It is generated at a specific date (or daily) and time-of-day (e.g. 9:50 or hourly, or every minute). A corresponding OB will be processed.

### Interrupt, update

An update interrupt can be generated by a DPV1 slave or a PNIO device respectively. At the DPV1 master or the PNIO controller respectively the receipt of the interrupt causes the OB 56 to be called up.

For detailed information on OB 56, refer to the *Reference Manual System Software for S7-300/400: System and Standard Functions*.

### Interrupt, vendor-specific

A vendor-specific interrupt can be generated by a DPV1 slave or a PNIO device respectively. At the DPV1 master or the PNIO controller respectively the receipt of the interrupt causes the OB 57 to be called up.

For detailed information on OB 57, refer to the *Reference Manual System Software for S7-300/400: System and Standard Functions*.

### IP address

To allow a PROFINET device to be addressed as a node on Industrial Ethernet, this device also requires an IP address that is unique within the network. The IP address is made up of 4 decimal numbers with a range of values from 0 through 255. The decimal numbers are separated by a period.

The IP address is made up of

- The address of the (subnet) network and
- The address of the node (generally called the host or network node).

### IRT

→ *Isochronous Real Time communications*

### Isochronous Real Time communications

Synchronized transmission method for the cyclic exchange of IO data between PROFINET devices.

A reserved bandwidth within the send clock is available for the IRT IO data. The reserved bandwidth guarantees that the IRT data can also be transferred even during another high network load (for example TCP/IP communication or additional real time communication) at reserved, synchronized intervals.

## LAN

Local Area Network; interconnects multiple computers within a company. The geographical topology of a LAN is limited to the local premises and is only available to the operating company or institution.

## LLDP

LLDP (Link Layer Discovery Protocol) is a manufacturer-independent protocol that allows information exchange between neighboring devices. It is defined in accordance with IEEE-802.1AB.

## Load memory

This memory contains objects generated by the programming device. Load memory is implemented by means of a plug-in Micro Memory Card of different memory capacities. The SIMATIC Micro Memory Card must be inserted to allow CPU operation.

## Load power supply

Power supply to the signal / function modules and the process I/O connected to them.

## Local data

→ *Data, temporary*

## MAC address

Each PROFINET device is assigned a worldwide unique device identifier in the factory. This 6-byte long device identifier is the MAC address.

The MAC address is divided up as follows:

- 3 bytes vendor identifier and
- 3 bytes device identifier (consecutive number).

The MAC address is normally printed on the front of the device.

Example: 08-00-06-6B-80-C0

## Master

When a master has the token, it can send data to other nodes and request data from other nodes (= active node).

## Memory Card (MC)

Memory Cards are memory media for CPUs and CPs. They are implemented in the form of RAM or FEPRAM. An MC differs from a Micro Memory Card only in its dimensions (MC is approximately the size of a credit card).

**Micro Memory Card (MMC)**

Micro Memory Cards are memory media for CPUs and CPs. Their only difference to the Memory Card is the smaller size.

**Module parameters**

Module parameters are values which can be used to configure module behavior. A distinction is made between static and dynamic module parameters.

**MPI**

The multipoint interface (MPI) represents the programming device interface of SIMATIC S7. It enables multiple nodes (PGs, text-based displays, OPs) to be operated simultaneously by one or more CPUs. Each node is identified by its unique (MPI) address.

**MPI address**

→ *MPI*

**NCM PC**

→ *SIMATIC NCM PC*

**Nesting depth**

A block can be called from another by means of a block call. Nesting depth is referred to as the number of simultaneously called code blocks.

**Network**

A network consists of one or more interconnected subnets with any number of nodes. Several networks can exist alongside each other.

**Network**

A network is a larger communication system that allows data exchange between a large number of nodes.

All the subnets together form a network.

**Non-isolated**

The reference potential of the control and on-load power circuits of non-isolated I/O modules is electrically interconnected.

**NTP**

The Network Time Protocol (NTP) is a standard for synchronizing clocks in automation systems via Industrial Ethernet. NTP uses the UDP wireless network protocol.

## OB

→ *Organization blocks*

## OB priority

The CPU operating system distinguishes between different priority classes, for example, cyclic program execution, process interrupt controlled program processing. Each priority class is assigned organization blocks (OBs) in which the S7 user can program a response. The OBs are assigned different default priority classes. These determine the order in which OBs are executed or interrupt each other when they appear simultaneously.

## Operating state

SIMATIC S7 automation systems know the following operating states: STOP, START, RUN.

## Operating system

The CPU operating system organizes all the CPU functions and processes which are not associated with a specific control task.

## Organization blocks

Organization blocks (OBs) form the interface between the CPU operating system and the user program. The order in which the user program is executed is defined in the organization blocks.

## Parameters

1. Variable of a **STEP 7** code block
2. Variable for declaring module response (one or several per module). All modules have a suitable basic factory setting which can be customized in **STEP 7**.  
There are static and dynamic parameters.

## Parameters, dynamic

Unlike static parameters, you can change dynamic module parameters during runtime by calling an SFC in the user program, e.g. limit values of an analog signal input module.

## Parameters, static

Unlike dynamic parameters, static parameters of modules cannot be changed by the user program. You can only modify these parameters by editing your configuration in **STEP 7**, for example, modification of the input delay parameters of a digital signal input module.

**PC station**

→ *SIMATIC PC Station*

**PG**

→ *Programming device*

**PLC**

→ *Programmable logic controller*

**PLC**

A PLC in the context of SIMATIC S7 --> is a programmable logic controller.

**PNO**

Technical committee that defines and further develops the PROFIBUS and PROFINET standards with the following homepage: <http://www.profinet.com>.

**Prioritized startup**

The term "prioritized startup" is used for the PROFINET functionality for accelerating the startup of IO devices in a PROFINET IO system with RT and IRT communications.

The function reduces the time that the correspondingly configured IO devices require in order to return to the cyclic user data exchange in the following cases:

- After the power supply has returned
- After a station has come back online
- After IO devices have been activated

**Priority class**

The S7 CPU operating system provides up to 26 priority classes (or "Program execution levels"). Specific OBs are assigned to these classes. The priority classes determine which OBs interrupt other OBs. Multiple OBs of the same priority class do not interrupt each other. In this case, they are executed sequentially.

**Process image**

The process image is part of CPU system memory. At the start of cyclic program execution, the signal states at the input modules are written to the process image of the inputs. At the end of cyclic program execution, the signal status of the process image of the outputs is transferred to the output modules.

### Process interrupt

A process interrupt is triggered by interrupt-triggering modules as a result of a specific event in the process. The process interrupt is reported to the CPU. The assigned organization block will be processed according to interrupt priority.

### Process-Related Function

→ *PROFINET Component*

### Product version

The product version identifies differences between products which have the same order number. The product version is incremented when forward-compatible functions are enhanced, after production-related modifications (use of new parts/components) and for bug fixes.

### PROFIBUS

Process Field Bus - European field bus standard.

### PROFIBUS device

Within the context of PROFINET, "device" is the generic term for:

- Automation systems (e.g. PLC, PC)
- Field devices (for example, PLC, PC, hydraulic devices, pneumatic devices)
- Active network components (e.g. switches, gateways, routers)
- PROFIBUS or other fieldbus systems

The main characteristics of a device is its integration into PROFINET communication by means of Ethernet or PROFIBUS.

The following device types are distinguished based on their attachment to the bus:

- PROFINET devices
- PROFIBUS devices

## PROFIBUS device

Within the context of PROFINET, "device" is the generic term for:

- Automation systems (e.g. PLC, PC)
- Field devices (for example, PLC, PC, hydraulic devices, pneumatic devices)
- Active network components (e.g. switches, gateways, routers)
- PROFIBUS or other fieldbus systems

The main characteristics of a device is its integration into PROFINET communication by means of Ethernet or PROFIBUS.

The following device types are distinguished based on their attachment to the bus:

- PROFINET devices
- PROFIBUS devices

## PROFIBUS DP

A PROFIBUS with the DP protocol that complies with EN 50170. DP stands for distributed peripheral (IO) = fast, real-time, cyclic data exchange. From the perspective of the user program, the distributed IOs are addressed in exactly the same way as the central IOs.

## PROFINET

Within the framework of Totally Integrated Automation (TIA), PROFINET is the consistent further development of:

- PROFIBUS DP, the established fieldbus and
- Industrial Ethernet, the communication bus for the cell level.

The experience gained from both systems was and is being integrated in PROFINET.

PROFINET as an Ethernet-based automation standard from PROFIBUS International (previously PROFIBUS Users Organization) defines a vendor-independent communication, automation, and engineering model.

## PROFINET ASIC

→ *ASIC*

## PROFINET CBA

As part of PROFINET, PROFINET CBA (Component Based Automation) is an automation concept that focuses on the following:

- Implementation of modular applications
- Machine - machine communication

PROFINET CBA lets you create distributed automation solutions, based on default components and partial solutions. This concept meets the demand for a greater modularity in the field of mechanical and systems engineering by extensive distribution of intelligent processes.

With Component Based Automation you can implement complete technological modules as standardized components that can be used in large systems.

You create the modular, intelligent components of the PROFINET CBA in an engineering tool (which may differ according to the device manufacturer). Components that are formed from SIMATIC devices are created with STEP 7, and are interconnected using the SIMATIC iMAP tool.

## PROFINET Component

A PROFINET component includes the entire data of the hardware configuration, the parameters of the modules, and the corresponding user program. The PROFINET component is made up as follows:

- Technological Function

The (optional) technological (software) function includes the interface to other PROFINET components in the form of interconnectable inputs and outputs.

- Device

The device is the representation of the physical programmable controller or field device including the I/O, sensors and actuators, mechanical parts, and the device firmware.

## PROFINET device

→ *PROFIBUS device*

## PROFINET device

A PROFINET device always has at least one Industrial Ethernet port. A PROFINET device can also have a PROFIBUS port, that is, as master with proxy functionality.



**PROFINET IO**

As part of PROFINET, PROFINET IO is a communication concept that is used to implement modular, distributed applications.

PROFINET IO allows you to create automation solutions, which are familiar to you from PROFIBUS.

PROFINET IO is implemented using the PROFINET standard for programmable controllers.

The STEP 7 engineering tool helps you to structure and configure an automation solution.

In STEP 7 you have the same application view, regardless of whether you are configuring PROFINET devices or PROFIBUS devices. You will program your user program in the same way for both PROFINET IO and PROFIBUS DP since you will use the extended blocks and system status lists for PROFINET IO.

**PROFINET IO controller**

Device used to address the connected IO devices. This means that the IO controller exchanges input and output signals with assigned field devices. The IO controller is often the controller on which the automation program runs.

**PROFINET IO device**

A decentralized field device that is assigned to one of the IO controllers (e.g. remote IO, valve terminals, frequency converters, switches)

**PROFINET IO Supervisor**

Programming device, PC or HMI device used for commissioning and diagnostics.

**PROFINET IO system**

PROFINET IO controller with assigned PROFINET IO devices.

**Programmable logic controller**

Programmable controllers (PLCs) are electronic controllers whose function is stored as a program in the control unit. The structure and wiring of the device does not therefore depend on the controller's function. A programmable logic controller is structured like a computer. It consists of a CPU with memory, input/output modules and an internal bus system. The IOs and the programming language are oriented to control engineering needs.

**Programming device**

Programming devices are essentially compact and portable PCs which are suitable for industrial applications. They are identified by a special hardware and software for programmable logic controllers.

## Proxy

→ *PROFINET device*

## Proxy

The PROFINET device with proxy functionality is the substitute for a PROFIBUS device on Ethernet. The proxy functionality allows a PROFIBUS device to communicate not only with its master but also with all nodes on PROFINET.

With PROFINET, existing PROFIBUS systems can be integrated into the PROFINET communication with the aid of an IE/PB link, for example. The IE/PB link then handles communication via PROFINET on behalf of the PROFIBUS components.

In this way, you can link both DPV0 and DPV1 slaves to PROFINET.

## Proxy

→ *Proxy*

## Proxy functionality

→ *Proxy*

## RAM

→ *Memory Card (MC)*

## RAM

RAM (Random Access Memory) is a semiconductor read/write memory.

## Real Time

Real time means that a system processes external events within a defined time.

Determinism means that a system reacts in a predictable (deterministic) manner.

In industrial networks, both these requirements are important. PROFINET meets these requirements. PROFINET is implemented as a deterministic real-time network as follows:

- The transfer of time-critical data between different stations over a network within a defined interval is guaranteed.

To this end, PROFINET has an optimized communication channel for real-time communication: real time (RT): Real Time (RT).

- An exact prediction of the time at which the data transfer takes place is possible.
- It is guaranteed that problem-free communication using other standard protocols, for example industrial communication for a programming device / PC, can take place within the same network.

**Real Time**

→ *Real Time*

**Reduction factor**

The reduction rate determines the send/receive frequency for GD packets on the basis of the CPU cycle.

**Reference ground**

→ *Ground*

**Reference potential**

Voltages of participating circuits are referenced to this potential when they are viewed and/or measured.

**Restart**

On CPU start-up (e.g. after is switched from STOP to RUN mode via selector switch or with POWER ON), OB100 (restart) is initially executed, prior to cyclic program execution (OB1). On restart, the input process image is read in and the **STEP 7** user program is executed, starting at the first instruction in OB1.

**Retentive memory**

A memory area is considered retentive if its contents are retained even after a power loss and transitions from STOP to RUN. The non-retentive area of memory flag bits, timers and counters is reset following a power failure and a transition from the STOP mode to the RUN mode.

Retentive can be the:

- Bit memory
- S7 timers
- S7 counters
- Data areas

**Router**

A router interconnects two subnets. A router works in a similar way to a switch. You can also enable/disable nodes for communication at the router. The communication nodes on various sides of a router can only communicate with one another if you have explicitly enabled communication between these nodes via the router. Real-time data cannot be exchanged beyond subnet boundaries.

**Router**

→ *Default Router*

## Router

→ *Switch*

## RT

→ *Real Time*

## Runtime error

Errors occurred in the PLC (that is, not in the process itself) during user program execution.

## Scan cycle check point

The cycle control point is the section of the CPU program processing in which the process image is updated.

## Segment

→ *Bus segment*

## Send clock

Period between two successive intervals for IRT or RT communication. The send clock is the shortest possible transmit interval for exchanging data. The calculated update times are multiples of the send clock.

The minimum possible update time thus depends on the minimum send clock of the IO controller that can be set.

If both the IO controller and the IO device support a send clock of 250  $\mu$ s, you can achieve a minimum update time of 250  $\mu$ s.

It is also possible to operate IO devices that only support a send clock of 1 ms on an IO controller that works with a send clock of 250  $\mu$ s. The minimum update time for the IO devices concerned is then at least 1 ms, however.

## SFB

→ *System function block*

## SFC

→ *System function*

## Signal module

Signal modules (SM) form the interface between the process and the PLC. There are digital input and output modules (input/output module, digital) and analog input and output modules. (Input/output module, analog)

**SIMATIC**

The term denotes Siemens AG products and systems for industrial automation.

**SIMATIC NCM PC**

SIMATIC NCM PC is a version of STEP 7 tailored to PC configuration. For PC stations, it offers the full range of functions of STEP 7.

SIMATIC NCM PC is the central tool with which you configure the communication services for your PC station. The configuration data generated with this tool must be downloaded to the PC station or exported. This makes the PC station ready for communication.

**SIMATIC NET**

Siemens Industrial Communication division for Networks and Network Components.

**SIMATIC PC Station**

A "PC station" is a PC with communication modules and software components within a SIMATIC automation solution.

**Slave**

A slave can only exchange data after being requested to do so by the master.

**SNMP**

SNMP (Simple Network Management Protocol) makes use of the wireless UDP transport protocol. It consists of two network components, similar to the client/server model. The SNMP manager monitors the network nodes and the SNMP agents collect the various network-specific information in the individual network nodes and store them in a structured form in the **MIB** (Management Information Base). This information allows a network management system to run detailed network diagnostics.

**STARTUP**

A START-UP routine is executed at the transition from STOP to RUN mode. Can be triggered by means of the mode selector switch, or after power on, or by an operator action on the programming device. An S7-300 performs a restart.

**STEP 7**

STEP 7 is an engineering system and contains programming software for the creation of user programs for SIMATIC S7 controllers.

## Subnet mask

The bits set in the subnet mask decides the part of the IP address that contains the address of the subnet/network.

In general:

- The network address is obtained by an AND operation on the IP address and subnet mask.
- The node address is obtained by an AND NOT operation on the IP address and subnet mask.

## Subnetwork

All the devices connected by switches are located in the same network - a subnet. All the devices in a subnet can communicate directly with each other.

All devices in the same subnet have the same subnet mask.

A subnet is physically restricted by a router.

## Substitute value

Substitute values are configurable values which output modules transfer to the process when the CPU switches to STOP mode.

In the event of an I/O access error, a substitute value can be written to the accumulator instead of the input value which could not be read (SFC 44).

## Switch

PROFIBUS is based on a bus topology. Communication nodes are connected by a passive cable - the bus.

In contrast, Industrial Ethernet is made up of point-to-point links: Each communication node is connected directly to one other communication node.

If a communication node needs to be connected to several other communication nodes, this communication node is connected to the port of an active network component- a switch. Other communications nodes (including switches) can then be connected to the other ports of the switch. The connection between a communication node and the switch remains a point-to-point link.

The task of a switch is therefore to regenerate and distribute received signals. The switch "learns" the Ethernet address(es) of a connected PROFINET device or other switches and forwards only the signals intended for the connected PROFINET device or connected switch.

A switch has a certain number of ports). At each port, connect a maximum of one PROFINET device or a further switch.

## System diagnostics

System diagnostics refers to the detection, evaluation, and signaling of errors that occur within the PLC, for example programming errors or module failures. System errors can be indicated by LEDs or in **STEP 7**.

**System function**

A system function (SFC) is a function that is integrated in the operating system of the CPU and can be called in the STEP 7 user program, when necessary.

**System function block**

A system function block (SFB) is a function block integrated in the CPU operating system that can be called in the STEP 7 user program when required.

**System memory**

System memory is an integrated RAM memory in the CPU. System memory contains the address areas (e.g. timers, counters, flag bits) and data areas that are required internally by the operating system (for example, communication buffers).

**System memory**

→ *Counter*

**System memory**

→ *Timers*

**System status list**

The system status list contains data that describes the current status of a SIMATIC S7. You can always use this list to obtain an overview of the following points:

- Status of the SIMATIC S7 extension.
- The current CPU configuration and configurable signal modules.
- The current states and processes in the CPU and in configurable signal modules.

**Terminating resistor**

The terminating resistor is used to avoid reflections on data links.

**Timer**

→ *Timers*

**Timers**

Timers are part of CPU system memory. The content of timer cells is automatically updated by the operating system, asynchronously to the user program. **STEP 7** instructions are used to define the precise function of the timer cell (for example, on-delay) and to initiate their execution (for example, start).

### TOD interrupt

→ *Interrupt, time-of-day*

### Token

Allows access to the bus for a limited time.

### Tool changer

→ *Changing IO devices during operation (changing partner ports)*

### Topology

Network structure. Commonly used structures:

- Bus topology
- Ring topology
- Star topology
- Tree topology

### Transmission rate

Data transfer rate (in bps)

### Twisted-pair

Fast Ethernet over twisted-pair cables is based on the IEEE 802.3u standard (100 base TX). The transmission medium is a shielded 2x2 twisted-pair cable with an impedance of 100 Ohm (AWG 22). The transmission characteristics of this cable must meet the requirements of category 5 (see glossary).

The maximum length of the connection between the terminal and the network component must not exceed 100 m. The cables are wired according to the 100 base TX standard using the RJ45 connector system.

### Ungrounded

Having no direct electrical connection to ground

### Update time

Within this time interval an IO device/IO controller in the PROFINET IO system is supplied with new data by the IO controller/IO device. The send cycle can be configured separately for each IO device and determines the interval at which data are sent from the IO controller to the IO device (outputs) as well as data from the IO device to the IO controller (inputs).



### **User program**

In SIMATIC, we distinguish between the operating systems of the CPU and user programs. The user program contains all instructions, declarations and data for signal processing required to control a plant or a process. It is assigned to a programmable module (for example CPU, FM) and can be structured in smaller units (blocks).

### **Varistor**

Voltage-dependent resistor

### **WAN**

Wide Area Network. Network beyond LAN boundaries which allows, for example, intercontinental communication. Legal rights do not belong to the user but to the provider of the communication network.

### **Work memory**

The working memory is integrated in the CPU and cannot be extended. It is used to run the code and process user program data. Programs only run in the working memory and system memory.



# Index

(

(PtP, 50

## A

Accessories, 90

for wiring, 99

Actuator/Sensor Interface, 50, 88

Addresses

Analog module, 124

Digital module, 122

Technological functions, 125

Addressing

Addressing PROFINET IO, 128

On PROFIBUS DP, 127

slot-specific, 119

Analog module

Addresses, 124

Application

in industrial environments, 232

in residential areas, 233

Application View, 74, 79

Approval

CE, 229

CSA, 230

FM, 231

Marine, 232

UL, 230

Approvals

Standards, 229

Arrangement

of the modules, 28

ASI, 50

Assembly dimensions

of the modules, 25

Asynchronous error, 194

Automation concept, 50, 75

## B

Back up

Operating system, 174

Basic knowledge, 3

Burst pulses, 234

Bus cables

Installation rules, 61

Bus connector, 62

Connecting the bus cable, 117

removing, 118

Setting the terminating resistor, 118

Bus connector

Connecting to module, 118

Bus connectors

plugging, 95

Bus termination, 66

Bus topology

Detection, 197

## C

Cabinet

Dimensions, 33

power loss dissipated, 35

Selecting and dimensioning, 32

Types, 34

Cable lengths

longer, 59

maximum, 63

MPI subnet, 59

PROFIBUS subnet, 59

Stub cables, 60

Cable routing inside buildings, 256

Cable shielding, 252

Ground, 43

Cables

Preparing, 106

shield, 252

Category, 270

CE

Approval, 229

Central unit, 24

- Clock synchronization
    - DP interface, 57, 58
    - MPI interface, 55
    - PROFIBUS DP Interface, 57
  - Commissioning
    - Check list, 132
    - CPU 31x-2 DP as a DP master, 154
    - CPU 31x-2 DP as a DP slave, 158, 213
    - CPU 31xC-2 DP as a DP master, 154
    - CPU 31xC-2 DP as a DP slave, 158
    - Hardware Requirements, 129
    - Procedure with the hardware, 130
    - Procedure with the software, 131
    - PROFINET IO, 165
    - Reaction to errors, 132
    - Software requirement, 131
  - Commissioning the CPU as DP master
    - Constant Bus Cycle Time, 156
    - Isochronous Updating of Process Image Partitions, 156
    - Sync/Freeze, 157
  - Communications concept, 50, 74
  - Component based Automation, 50
  - Component Based Automation, 75
  - Connecting
    - PG, 141, 142, 143, 144, 146
    - Sensors and actuators, 105
    - Spring terminals, 105
  - Connecting actuators, 105
  - Connecting cables
    - for interface modules, 29
  - Connecting sensors, 105
  - Consistency, 127, 128
  - Continuous shock, 238
  - Controlling
    - of tags, 192
  - CP 343-1, 78
  - CP 443-1 Advanced, 78
  - CPU
    - CPU memory reset, 137, 140
    - Wiring, 103
  - CPU 313C-2 DP
    - commissioning as a DP master, 154
    - commissioning as DP-Slave, 159
  - CPU 314C-2 DP
    - commissioning as a DP master, 154
    - commissioning as DP-Slave, 159
  - CPU 315-2 DP
    - commissioning as a DP master, 154
    - commissioning as DP-Slave, 159
  - CPU 316-2 DP
    - commissioning as DP-Slave, 159
  - CPU 317-2 DP
    - commissioning as a DP master, 154
  - CPU 318-2 DP
    - commissioning as DP-Slave, 159
  - CPU memory reset, 137
    - CPU activities, 139
    - MPI parameters, 139
  - CSA
    - Approval, 230
- ## D
- Data consistency, 127, 128
  - Default addressing, 119
  - Definition
    - Electromagnetic Compatibility, 234
  - Degree of protection IP 20, 239
  - Delivery state of the CPU
    - Lamp images during reset, 181
    - Properties, delivery state, 180
    - Restore delivery state, 180
  - Device-specific diagnostics, 223
  - Diagnostic address, 210, 215
    - with direct data exchange, 212
  - Diagnostic buffer, 196
  - Diagnostics
    - configured address area, 221
    - device-specific, 223
    - in DP Master mode, 209
    - with Diagnosing Hardware, 198
    - with LEDs, 201
    - with system functions, 196
  - Digital module
    - Addresses, 122
  - Digital output module
    - Replacement fuse, 186
    - Replacing fuses, 187
  - Direct data exchange, 163
  - DP interface
    - Clock synchronization, 57, 58
  - DP master, 71
    - Class 2, 71
    - Interrupts, 217
  - DP master system, 71
  - DP slave, 71

**E**

Electromagnetic Compatibility, 234  
 Electrostatic discharge, 234  
 EMC, 234  
   Definition, 243  
   Fault-free installation, 247  
 Emission of radio interference, 235  
 Engineering tool, 74  
 Equipotential bonding, 254  
 Equipotential bonding - lightning protection, 261, 263  
 Equipotential bonding conductor, 44  
 Error  
   Asynchronous, 194  
   Synchronous, 194  
 Error-free operation of the S7-300, 241  
 Event detection, 211, 216  
 Expansion module, 24

**F**

F system, 270  
 Fail-safe system, 270  
 Fieldbus integration, 73  
 FM  
   Approval, 231  
 Forcing, 193  
 Front connector coding  
   Removing from front connector, 185  
   Removing from module, 184  
 Front connectors  
   encoding, 108  
   plugging, 108  
   Preparing, 106  
   Wiring, 100, 107  
 Full assembly, 31

**G**

General technical data, 229  
 Ground bonding for EMC-compliant installation, 247  
 Grounding  
   Grounding, 45  
 Grounding concept, 40  
 GSD file, 78

**H**

Highest MPI address, 52  
 Highest PROFIBUS DP address, 52  
 HMI, 71

**I**

I&M data, 189  
 Identification, 208  
 Identification and maintenance data, 189  
 Identification code for Australia, 232  
 Identification data, 189  
 Identifier-related diagnostic data, 221  
 IE/PB link, 74  
 IEC 61131, 232  
 Industrial Ethernet, 50, 71  
 Inscription labels, 90  
 installation  
   arranging modules, 28  
   horizontal, 24  
   vertical, 24  
 Installation  
   in cabinets, 32  
   of the modules, 95  
   ungrounded reference potential, 39  
 Installation  
   grounded reference potential, 38  
 Installing  
   of the modules, 184  
 Installing EMC plants, 243  
 Insulation test, 239  
 Interconnection, 73  
 Interface module  
   Connecting cables, 170  
 Interface modules  
   Connecting cables, 29  
 Interfaces  
   MPI interface, 54  
   MPI interface:Connectable devices, 54  
   PROFIBUS DP interface, 56  
   PROFIBUS DP interface:Operating modes with two  
   DP interfaces, 56  
   PtP interface, 88  
 Interfaces PROFIBUS DP interface  
   Connectable devices, 57  
 Interferences  
   electromagnetic, 243  
 Interrupt  
   on the DP master, 217  
 IO controller, 71  
 IO device, 71  
 IO supervisor, 71  
 IO system, 71

- L**
- Labeling strips
  - Assignment to modules, 113
  - inserting, 113
- Lightning protection equipotential bonding, 261
- Lightning protection zone concept, 259
- Lightning protector, 262
- Load circuit
  - Ground, 44
- Load current
  - determining, 47
- Load power supply
  - from PS 307, 48
- Load voltage
  - Connecting the reference potential, 44
- Local equipotential bonding, 262
  
- M**
- Mains
  - grounded, 36
- Mains voltage
  - Selecting the mains voltage, 102
- Mains voltage selector switch, 102
- Maintenance data, 189
- Manufacturer ID, 220
- Marine
  - Approval, 232
- Material
  - Structure, 90
- Mechanical environmental conditions, 237
- MIB, 199
- Micro Memory Card, 134
  - Formatting, 140
  - Inserting and removing when power is switched off, 135
  - Inserting/removing, 135
- Module
  - Arrangement, 28, 30
  - Assembly dimensions, 25
  - installing, 184
  - Installing, 95
  - isolated, 40
  - labeling, 113
  - non-isolated, 40
  - removing, 183
  - replacing, 182
  - Start addresses, 119
- Module replacement
  - Reaction of the S7-300, 185
  - Rules, 182
- Monitoring
  - of tags, 192
- Monitoring and controlling a tag
  - Monitor tag, 148
- Monitoring and modifying tags
  - Creating a tag table, 148
  - modifying tags, 149
  - setting the trigger points, 149
- Monitoring and modifying variable
  - establishing a connection to the CPU, 150
  - Modifying outputs in CPU STOP mode, 151
  - opening the VAT, 150
  - Saving the variable table, 150
- Mounting rail
  - connecting the protective conductor, 101
  - Fixing screws, 92
  - Ground conductor, 91
  - Length, 25
  - mounting holes, 92
  - Preparing, 91
- MPI, 49, 54
  - Maximum number of nodes, 52
  - Maximum transmission rate, 51
- MPI address
  - default, 52
  - highest, 52
  - Recommendation, 53
  - Rules, 52
- MPI and PROFIBUS subnet, 68
- MPI interface
  - Clock synchronization, 55
- MPI subnet
  - Example, 64
  - maximum distances, 64
  - Segment, 59
  - Terminating resistor, 66
- Multi-Point Interface, 49
  
- O**
- Objective of this documentation, 3
- Open components, 89
- Operating system
  - Back up, 174
- Outdoor routing of cables, 258

**P**

PC, 78  
 PG  
     Access to remote networks, 86  
     Connecting, 141, 142, 143, 144, 146  
     ungrounded configuration, 146  
 Point-to-point communication, 50  
 Potential differences, 44  
 Power on  
     initial, 136  
     Requirements, 136  
 Power supply module  
     Selecting the mains voltage, 102  
 PROFIBUS, 49, 71, 74  
 PROFIBUS address  
     Recommendation, 53  
 PROFIBUS bus cable  
     Properties, 61  
 PROFIBUS device, 70  
 PROFIBUS DP  
     Commissioning, 152  
     Direct data exchange, 163  
     DP address areas, 152  
     DP diagnostics addresses, 153  
     Maximum number of nodes, 52  
     Maximum transmission rate, 51  
 PROFIBUS DP address  
     default, 52  
     highest, 52  
     Rules, 52  
 PROFIBUS DP Interface, 56  
 PROFIBUS DP Interface  
     Clock synchronization, 57  
 PROFIBUS subnet  
     Cable lengths, 59  
     Example, 67  
 PROFIBUS terminator, 66  
 PROFINET, 50, 71, 74  
     CBA, 50  
     Commissioning, 166, 196  
     Commissioning via MPI/DP, 166  
     Commissioning via PN interface, 167  
     Configuring, 167  
     Environment, 69  
     Implementation, 74  
     IO, 50  
     Send clock, 79  
     Standard, 75  
     Update times, 79  
     Update times of CPU 319-3 PN/DP, 80

PROFINET CBA, 50, 75  
 PROFINET devices, 70  
 PROFINET diagnostics  
     Evaluation, 227  
     Information, 226  
     Maintenance, 228  
     Maintenance information, 228  
 PROFINET IO, 50, 77  
     Commissioning, 165  
 Programming, 74  
 Protect digital output modules from inductive surge, 267  
 Protection class, 239  
 Protective conductor  
     Connecting to the mounting rail, 91  
     Connecting to the rail, 101  
 Protective grounding  
     measures, 43  
 Protective measures  
     for the overall system, 37  
 Proxy, 74  
 Proxy functionality, 74  
 PtP interface, 88  
 Pulseshaped disturbance, 234

**R**

Redundancy, 270  
 Redundant system, 270  
 Reference potential  
     grounded, 38  
     ungrounded, 39  
 Removing  
     of the modules, 183  
 Replacing  
     Fuses, 187  
     Module, 182  
 Replacing fuses  
     Digital output module, 187  
 Routing, 86  
 Routing an equipotential bonding conductor, 254  
 RS 485  
     Bus connector, 62  
 RS 485 repeater, 62  
 Rules and regulations for error-free operation, 241

**S**

- S7 Distributed Safety, 270
- S7 F/FH Systems, 270
- S7-300
  - initial power on, 136
- S7-300 configuration
  - Components, 20
  - Example, 19
- Safety integrity level, 270
- Scope of this documentation, 9
- Scope of this manual, 3
- Segment, 51
  - in the MPI subnet, 59
  - on the PROFIBUS subnet, 59
- SF
  - LED, evaluation, 202
- SFB52, 197
- SFC 103, 62, 197
- SFC 13, 196
- SFC 51, 196
- SFC 6, 197
- SFC14, 127, 128
- SFC15, 127, 128
- Shielding contact element, 26, 114
  - installing, 115
  - Terminating cables, 116
- Shielding terminals, 26
- Shipping conditions, 236
- Shock, 238
- SIL, 270
- SIMATIC iMap, 75
- SIMATIC Manager, 147
  - start, 147
- SIMOTION, 78
- Sinusoidal disturbance, 235
- Slave diagnostics
  - installation, 218
  - Reading, example, 213
- Slot number label, 90
- Slot numbers
  - Assigning, 96
  - Mounting, 97
- SNMP, 200
  - Integration into STEP 7, 199
  - MIB, 199
  - Network diagnostics, 199
- SOFTNET PROFINET, 78
- Standards and approvals, 229

**Startup**

- CPU 31x-2 DP as a DP master, 155
- CPU 31x-2 DP as a DP master, 171
- CPU 31x-2 DP as a DP slave, 159
- CPU 31xC-2 DP as a DP master, 155, 171
- CPU 31xC-2 DP as a DP slave, 159
- Station status, 219
- stepping mode, 192
- Storage conditions, 236
- Strain relief, 107
- Stub cables
  - Length, 60
- Subnet, 49
- SYNC/FREEZE, 157
- Synchronous error, 194

**T****Tags**

- Controlling, 192
- Forcing, 193
- Monitoring, 192
- Technical data
  - Electromagnetic Compatibility, 234
  - Shipping and storage conditions, 236
- Temperature, 236
- Terminating resistor
  - MPI subnet, 66
  - Setting the bus connector, 118
- Test voltage, 239
- Tools
  - Structure, 90
- Transfer memory, 160
- Troubleshooting, 194

**U****UL**

- Approval, 230
- Ungrounded configuration
  - connecting a PG, 146
- Update
  - Requirements, 175
  - Via network, 177
- Update using a network
  - Requirements, 177
- Update via Micro Memory Card, 176



**V**

Vibration, 238

**W**

WinLC, 78

Wiring

Accessories required, 99

Front connectors, 107

Front Connectors, 100

PS and CPU, 100, 103

Rules, 100

Tools and materials required, 99

