

Operating Instructions Edition 07/2006

Industrial PC
Panel PC 877

simatic

SIEMENS

SIEMENS

SIMATIC

Industrial PC SIMATIC Panel PC 877

Operating instructions

Foreword	1
Safety information	2
Description	3
Application planning	4
Installation	5
Connecting	6
Integration into an automation system	7
Commissioning	8
Operation and configuration	9
Operation	10
Functions	11
Maintenance and service	12
Alarm, error and system messages	13
Troubleshooting/FAQs	14
Technical data	15
Dimension drawings	16
Detailed descriptions	17
Appendix	A
ESD directives	B
List of abbreviations / acronyms	C

Safety Guidelines

This manual contains notices you have to observe in order to ensure your personal safety, as well as to prevent damage to property. The notices referring to your personal safety are highlighted in the manual by a safety alert symbol, notices referring only to property damage have no safety alert symbol. These notices shown below are graded according to the degree of danger.



Danger

indicates that death or severe personal injury **will** result if proper precautions are not taken.



Warning

indicates that death or severe personal injury **may** result if proper precautions are not taken.



Caution

with a safety alert symbol, indicates that minor personal injury can result if proper precautions are not taken.

Caution

without a safety alert symbol, indicates that property damage can result if proper precautions are not taken.

Notice

indicates that an unintended result or situation can occur if the corresponding information is not taken into account.

If more than one degree of danger is present, the warning notice representing the highest degree of danger will be used. A notice warning of injury to persons with a safety alert symbol may also include a warning relating to property damage.

Qualified Personnel

The device/system may only be set up and used in conjunction with this documentation. Commissioning and operation of a device/system may only be performed by **qualified personnel**. Within the context of the safety notes in this documentation qualified persons are defined as persons who are authorized to commission, ground and label devices, systems and circuits in accordance with established safety practices and standards.

Prescribed Usage

Note the following:



Warning

This device may only be used for the applications described in the catalog or the technical description and only in connection with devices or components from other manufacturers which have been approved or recommended by Siemens. Correct, reliable operation of the product requires proper transport, storage, positioning and assembly as well as careful operation and maintenance.

Trademarks

All names identified by ® are registered trademarks of the Siemens AG. The remaining trademarks in this publication may be trademarks whose use by third parties for their own purposes could violate the rights of the owner.

Disclaimer of Liability

We have reviewed the contents of this publication to ensure consistency with the hardware and software described. Since variance cannot be precluded entirely, we cannot guarantee full consistency. However, the information in this publication is reviewed regularly and any necessary corrections are included in subsequent editions.

(A)

가

Table of contents

1	Foreword	1-1
1.1	Overview	1-1
2	Safety information	2-3
2.1	Safety information	2-3
2.2	General information	2-6
3	Description	3-1
3.1	Design	3-1
3.2	Technical features.....	3-3
3.3	Accessories.....	3-5
4	Application planning	4-1
4.1	Overview	4-1
4.2	Unpacking and checking the delivery	4-2
4.3	Device identification data	4-3
4.4	Mounting Positions and Fastening.....	4-4
4.4.1	Installation guidelines.....	4-4
4.4.2	Permitted mounting positions.....	4-6
4.4.3	Type of fixation.....	4-7
4.4.4	Protection against dust and water	4-8
4.5	Mounting cut-out	4-9
4.5.1	Preparing the mounting cut-out.....	4-9
4.5.2	Mounting depth of the device.....	4-11
4.6	EMC directive.....	4-12
5	Installation	5-1
5.1	Securing the device with clamps.....	5-1
5.2	Securing the device with screws.....	5-3
6	Connecting	6-1
6.1	Connection and operator control components.....	6-1
6.2	Connecting the 100 V to 240 V AC power supply.....	6-4
6.3	Connecting the 24 V DC power supply.....	6-6
6.4	Connecting the equipotential bonding circuit.....	6-7

7	Integration into an automation system	7-1
7.1	Overview	7-1
7.2	Device in a SIMATIC S7 configuration.....	7-2
7.2.1	MPI/PROFIBUS-DP network.....	7-2
7.2.2	Connecting an S7 automation system	7-3
7.3	Networking via Industrial Ethernet	7-4
8	Commissioning	8-1
8.1	Overview	8-1
8.2	Switch on the device	8-2
8.3	Setting up the Microsoft Windows operating system	8-3
8.4	Installing applications and drivers	8-4
8.5	BIOS settings	8-9
8.6	Microsoft Windows operating system	8-10
8.6.1	Enables	8-10
8.6.2	Windows 2000 Professional.....	8-11
8.6.3	Windows XP Professional.....	8-12
8.7	USB.....	8-13
9	Operation and configuration.....	9-1
9.1	Normal operation.....	9-1
9.1.1	Switch on the device	9-1
9.1.2	Logging on to the operating system via the onscreen keyboard (OSK)	9-3
9.1.3	Switching off the device	9-4
9.2	Additional Drivers and Applications	9-5
9.2.1	Overview	9-5
9.2.2	Calibrating the touch screen, UPDD	9-6
9.2.3	Enable/disable touch functionality.....	9-8
9.2.4	Windows Security Center (Windows XP Professional only)	9-10
9.2.5	KeyTools (for key panel devices only)	9-12
9.2.6	Screen keyboard (for touch panel device only).....	9-13
9.2.7	Setbrightness	9-14
9.2.8	CheckLanguageID	9-15
9.2.9	Multilingual settings for the operating system	9-16
9.2.10	DVD ROM/CD RW	9-18
9.2.11	USB keyboard controller	9-19
10	Operation.....	10-1
10.1	Status displays	10-1
10.2	General control elements	10-2
10.3	Device with key panel	10-3
10.3.1	Using the keyboard	10-4
10.3.2	Using the direct control key module.....	10-10
10.3.3	Labelling function keys and softkeys	10-14
10.3.4	Using the integrated mouse	10-16
10.4	Device with touch screen	10-17
10.4.1	Using the touch screen	10-18
10.5	Disk drive.....	10-19
10.6	Transferring authorizations	10-20

11	Functions	11-1
11.1	Overview	11-1
11.2	Safecard on Motherboard (SOM).....	11-2
11.3	Temperature monitoring.....	11-4
11.4	Watchdog (WD).....	11-5
11.5	Fan monitoring	11-6
12	Maintenance and service	12-1
12.1	Servicing	12-1
12.2	Replacement parts.....	12-3
12.3	Separating the control unit from the computer unit.....	12-4
12.4	Installing and removing hardware components	12-7
12.4.1	Repairs.....	12-7
12.4.2	Open the device.....	12-8
12.4.3	Installing and removing memory modules	12-10
12.4.4	Installing PCI / AT cards	12-12
12.4.4.1	Notes on the modules.....	12-12
12.4.4.2	Installing / removing expansion modules.....	12-13
12.4.4.3	Exchanging the RAID controller PCI card.....	12-15
12.4.5	Disk drives.....	12-16
12.4.5.1	Options of installing disk drives.....	12-16
12.4.5.2	Installing / removing a drive bay	12-18
12.4.5.3	Removing and installing an optical drive	12-21
12.4.5.4	Removing and installing a 3.5" hard disk.....	12-24
12.4.6	Replacing the backup battery	12-25
12.4.7	Removing/Installing the Power Supply	12-27
12.5	Installing Software.....	12-29
12.5.1	General installation procedure.....	12-29
12.5.2	Setting up the partitions for Windows operating systems.....	12-30
12.5.3	Compatibility of the Restore DVD	12-32
12.5.4	Restoring the factory state of the software using the Restore DVD	12-33
12.5.5	Installing Microsoft Windows operating systems	12-35
12.5.5.1	Operating system not installed.....	12-35
12.5.5.2	Booting from the Recovery CD	12-36
12.5.5.3	Installing the Microsoft Windows operating system (not for RAID).....	12-37
12.5.5.4	Installing the Microsoft Windows operating system (for RAID).....	12-38
12.5.6	Installing individual drivers	12-39
12.5.7	Operation of two hard disks	12-40
12.5.7.1	2 HDD system.....	12-40
12.5.7.2	RAID system with Promise Fast Track Controller TX2300.....	12-41
12.5.7.3	Installing the RAID Controller software.....	12-44
12.5.8	Installing burner and DVD software	12-45
12.5.9	Backing up the hard disk.....	12-46
13	Alarm, error and system messages	13-1
13.1	Boot error messages.....	13-1
13.2	Introduction to the BIOS beep codes.....	13-3
13.3	BIOS beep codes.....	13-5

14	Troubleshooting/FAQs	14-1
14.1	General problems.....	14-1
14.2	Problems when Using Modules of Third-party Manufacturers.....	14-2
14.3	Temperature limits	14-3
15	Technical data	15-1
15.1	General technical data	15-1
15.2	Power requirements of the components	15-8
15.3	Device with AC voltage supply.....	15-9
15.4	Device with DC voltage supply	15-10
15.5	Keyboard table	15-11
16	Dimension drawings	16-1
16.1	Panel PC 877 dimensional drawing.....	16-1
16.2	Dimensional drawings for the installation of expansion modules	16-3
17	Detailed descriptions	17-1
17.1	Motherboard.....	17-1
17.1.1	Structure and functions of the motherboard.....	17-1
17.1.2	Technical features of the motherboard	17-2
17.1.3	Position of the ports on the motherboard.....	17-4
17.1.4	External interfaces	17-5
17.1.5	Front interfaces	17-13
17.1.6	Internal interfaces.....	17-18
17.2	Bus board.....	17-24
17.2.1	Layout and principle of operation.....	17-24
17.2.2	Assignment of the PCI IRQ channels to the PCI slots.....	17-25
17.2.3	Exclusive PCI hardware interrupt.....	17-26
17.2.4	ISA slot pin assignment.....	17-27
17.3	Operating system licenses	17-29
17.4	Cables	17-30
17.5	System resources	17-31
17.5.1	Currently allocated system resources.....	17-31
17.5.2	System resources used by the BIOS/DOS	17-32
17.5.2.1	I/O address allocation	17-32
17.5.2.2	Interrupt Assignments	17-34
17.5.2.3	Memory address assignments	17-35
17.6	BIOS setup.....	17-36
17.6.1	Overview	17-36
17.6.2	Starting BIOS Setup.....	17-37
17.6.3	BIOS setup menus	17-38
17.6.4	Main menu.....	17-40
17.6.5	Advanced menu	17-51
17.6.6	Security menu	17-59
17.6.7	Power menu	17-61
17.6.8	Boot menu	17-62
17.6.9	Version menu	17-64
17.6.10	Exit menu	17-65
17.6.11	BIOS setup default settings.....	17-66

A	Appendix.....	A-1
	A.1 Certificates and guidelines.....	A-1
	A.1.1 Guidelines and declarations.....	A-1
	A.1.2 Certificates and approvals	A-3
	A.1.3 Electrostatic charging of individuals.....	A-5
	A.2 Additional support	A-6
B	ESD directives	B-1
	B.1 ESD guideline	B-1
C	List of abbreviations / acronyms	C-1
	C.1 Abbreviations	C-1
	Glossary	Glossary-1
	Index.....	Index-1

Tables

Table 4-1	Dimensions for the mounting cut-out in mm	4-10
Table 10-1	Keyboard codes	10-11
Table 13-1	Converting the beep codes in a Hex display	13-3
Table 16-1	Panel PC 877 dimensions in mm.....	16-2

Foreword

1.1 Overview

Purpose of the manual

These operating instructions contain all the information you need for commissioning and using the SIMATIC Panel PC 877.

It is intended both for programming and testing personnel who commission the device and connect it with other units (automation systems, programming devices), as well as for service and maintenance personnel who install add-ons or carry out fault/error analyses.

Required basic knowledge

A solid background in personal computers and Microsoft operating systems is required to understand this manual. General knowledge in the field of automation control engineering is recommended.

Scope of this manual

This manual applies to devices with the order numbers 6AV781....

Approvals

For more information, please refer to the chapter "Certificates and Guidelines" in the appendix.

CE marking

For more information, please refer to "Directives and Declarations" in the "Certificates and Guidelines" section of the appendix.

Standards

Please refer to sections "Application planning" and "Technical data".

Position in the information landscape

The documentation for the Panel PC includes the following sections:

- SIMATIC Panel PC 877, Operating Instructions (compact) with the following information:
 - Commissioning
 - Legal information
- SIMATIC Panel PC 877, Operating Instructions

The documentation is supplied with the Panel PC in electronic form as a PDF file on the "Documentation and Drivers" CD. The documentation is available in German, English, French, Italian and Spanish.

Additional information about the Windows operating system is available on the Internet at the Microsoft homepage at <http://www.Microsoft.com>.

Conventions

The following text notation will facilitate reading this manual:

Representation	Validity
"File"	<ul style="list-style-type: none">• Terminology that occurs in the user interface, e.g., dialog names, tabs, buttons, menu commands• Required parameters such as limit values, tag values• Path information
"File > Edit"	Operational sequences, e.g., menu commands/shortcut menu commands.
<F1>, <Shift>+<F1>	Keys and key combinations

The term "Panel PC 877", "control unit" and "computer unit" is uniformly referred to as the "device" in these operating instructions. The full term is only used when a concrete reference is necessary.

Note

A note is important information about the product, handling the product or a reference to specific sections of the documentation that require special consideration.

Trademarks

All names labeled with ® symbol are registered trademarks of Siemens AG. Other names used in this documentation may be trademarks, the use of which by third parties for their own purposes could violate the rights of the owner.

HMI®
SIMATIC®
SIMATIC HMI®
SIMATIC WinCC®
SIMATIC WinCC flexible®
Panel PC 877®

2

Safety information

2.1 Safety information



Warning
Emergencies

In the event of a device fault, interrupt the power supply immediately. Inform the customer service personnel responsible. Malfunctions can occur when the operator controls or power cable are damaged or when liquids or foreign objects penetrate the device.



Warning

Following the results of a risk analysis, additional protection equipment on the machine or the system is necessary to avoid endangering persons. With this, especially the programming, configuration and wiring of the inserted I/O modules have to be executed, in accordance with the necessary risk analysis identified safety performance (SIL, PL or Cat.). The intended use of the device has to be ensured.

The proper use of the device has to be verified with a function test on the system. With this programming, configuration and wiring errors can be identified. The test results have to be documented and if necessary inserted into the relevant inputs.

Note

This device corresponds to the regulations of the EU low-voltage directive and the GPSG, verified by conformity with national and international standards (DIN EN, IEC) by a UL approval (cULuc). Please comply with all the information in these operating instructions when assembling the device.

Electrical connection



Warning

Disconnect the device from the mains before every intervention.

Do not touch power lines or data transmission lines during electrical storms and do not connect any cables.

System expansions

Only install system expansion devices designed for this device. If you install other expansions, you may damage the system or violate the safety requirements and regulations for radio frequency interference suppression. Contact your technical support team or where you purchased your PC to find out which system expansion devices may safely be installed.

Caution

If you install or exchange system expansions and damage your device, the warranty becomes void.

High frequency radiation

Caution

Unintentional operating situations

High frequency radiation, e.g. from cell phones, can cause unintentional operating situations under some circumstances. Further information is available in the section "EMC requirements" of the "Technical data" chapter.

Handling and disposal of lithium batteries



Warning

Danger of explosion and the release of harmful substances!

Do not throw lithium batteries into fire, do not solder onto the cell body, do not open, do not short circuit, do not reverse pole, do not heat above 100 °C, dispose of according to regulations, and protect from direct sunlight, moisture and condensation.

Replace lithium batteries with the same brand or a brand recommended by the manufacturer.

Dispose of used lithium batteries as hazardous waste, individually, in accordance with the local regulations.

Repairs

Only authorized personnel are permitted to repair the device.



Warning

Unauthorized opening of and improper repairs to the device may result in substantial damage to equipment or endanger the user.

2.2 General information

Overview

Caution

The device is approved for operation in closed rooms only. The guarantee is void if this stipulation is ignored.

Avoid extreme environmental operating conditions. Protect your device against dust, moisture and heat. For additional information, refer to the Technical data.

Do not place the device in direct sunlight.

Transport

Unpack the device at its installation location. Transport the device only in the original packaging. Do not transport the device when it is mounted.

Notice

Adhere to these stipulations each time the device is transported, otherwise the guarantee is void.

Caution

Condensation

When transporting the device at low temperatures, ensure that no moisture gets on or into the device. This also applies if the device is subjected to extreme changes in temperature.

Commissioning

Allow the device to slowly adjust to room temperature before commissioning the device. Do not place the device near heat radiation. If moisture condensation occurs, wait at least 12 hours before you switch on the device.

Vibration

Optical drives are sensitive to vibration. Inadmissible vibration during operation may result in loss of data or damage to the drive or data medium.

Before transporting the device, wait at least 20 seconds to allow the drive to stop completely.

Tools & downloads

Please check regularly if updates and hotfixes are available for download to your device.

Downloads are available on the Internet at <http://www.siemens.com/asis> under "Support". Click on "Software Tools & Downloads" on "Overview Panel PCs" Using the global search function, you can then also search for any downloads you require.

Processor and optical drive

Notice

An optical drive should only be operated in a mechanically undisturbed environment without vibrations and shock.

Safety-relevant applications



Warning

Maloperation

Do not perform safety-relevant functions of the user software with the touch screen.

Chemical stability

Caution

Adhere to the information regarding chemical resistance of the panel front. Please go to <http://www.siemens.com/asis> under "Tools & Downloads" for more information. Enter the article ID 16532108 as the search term. The available articles are displayed.

Sources of light

Notice

Position the screen so that it is not subject to direct sunlight or other strong sources of light.

Defective pixels in the display

At present, the manufacturing process of modern displays does not guarantee that all pixels of the display will be perfect. A small number of defective pixels in the display is therefore unavoidable. This does not present a functional problem as long as the defective pixels are not bunched in one location.

Further information is available in the section "General technical data" of the "Technical data" chapter.

Burn-in effect on TFT displays

A permanent picture with bright images can lead to a burn-in effect on the TFT LCD.

If a screen saver is activated, please observe the following:

- The liquid crystals in screen savers which actuate active black when the backlighting is on, e.g. flying stars "starfield simulation," renew themselves. Pay attention to the length of time the backlighting is activated
- The following applies to screen savers which turn off the the backlighting: Each time the backlighting is turned on, its life is reduced by 50 minutes.

Consider the following carefully:

- Screen saver
- Switch off the backlighting regularly
- Permanent display of the customer application

Description

3.1 Design

Design

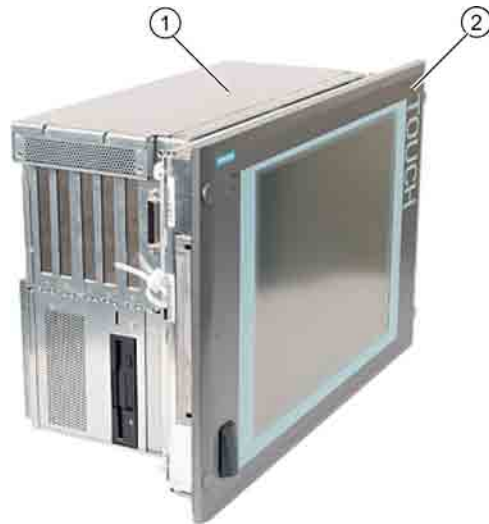

Figure 3-1 Panel PC 877

- 1 Computer unit
- 2 Control unit

Brief description

The device is available with different control units which are distinguished by the size of the display and by the membrane keyboard or touch screen.

Keyboard variants

- Color display with backlighting:
 - 12" TFT technology with 800 x 600 resolution
 - 15" TFT technology with 1024 x 768 resolution
- Membrane keyboard with alphanumeric keys, numeric keys, cursor keys and control keys
- Function keys and softkeys
- Integrated mouse
- LEDs for power supply, temperature, softkeys, <Shift> and <ACK> keys
- Front-mounted USB 2.0 interface for connecting external I/O devices. All fronts are also available without USB interfaces accessible from the front.

Touch screen variants

- Color display with backlighting
 - 15" TFT technology with 1024 x 768 resolution
 - 19" TFT technology with 1280 x 1024 resolution
- LEDs for power supply and temperature
- Front-mounted USB 2.0 interface for connecting external I/O devices. All fronts are also available without USB interfaces accessible from the front.

For additional information, refer to the Technical data.

3.2 Technical features

General features	
Slots for add-ons	<ul style="list-style-type: none"> • 2x PCI long • 2x PCI/ISA shared long • 1x ISA long • Note: The RAID1 option takes one PCI slot.
Graphic	VIA ProSavage 8 Graphics memory 8, 16 or 32 MB taken from main memory CRT: <ul style="list-style-type: none"> • up to 1600 x 1200 pixels, 60 Hz, 16-bit color depth • up to 1280 x 1024 pixels, 100 Hz, 32-bit color depth • LCD: • LVDS or DVI up to 1280 x 1024 / 18-bit TFT
Disk drive	Floppy disk drive
Interfaces	
PROFIBUS/MPI	12 Mbps, electrically isolated, compatible to CP 5611
Ethernet	10/100 Mbit/s, RJ45
USB	2x USB 2.0, high current
Serial	COM1 V.24, COM2 V.24
Parallel	LPT1
Monitor	1 x DVI-I VGA monitors can be connected with a DVI/VGA adapter, to be purchased separately.
Keyboard	PS/2
Mouse	PS/2

3.2 Technical features

Configuration options	
Power supply	<ul style="list-style-type: none"> • 100V/240V AC, 360 W; wide range; with bridging brief power failures in accordance with NAMUR: maximum 20 ms at 0.85 x U_n (U_n = rated voltage) • 24 V DC, 265 VA, optional, only in connection with Intel® Pentium Mobile
Processor	<ul style="list-style-type: none"> • Intel® Celeron 2 GHz, 400 MHz Front Side Bus FSB, 1024 Kbytes Second Level Cache • Intel® Pentium 4 2.8 GHz, 533 MHz Front Side Bus FSB, 512 Kbytes Second Level Cache • Intel® Pentium 4 Mobile 2.2 GHz, 400 MHz Front Side Bus FSB, 512 Kbytes Second Level Cache
Main memory	2-socket SDRAM DDR266: 256 MB, 512 MB, 1 GB, 2 GB
Hard disks	<ul style="list-style-type: none"> • 1 x 3.5" hard disk ≥ 40 GB • 1 x 3.5" hard disk ≥ 80 GB • 2 x 2.5" hard disks ≥ 60 GB with RAID 1 system SATA
Disk drive	<ul style="list-style-type: none"> • Without • DVD-ROM • CD-RW/DVD drive
Operating system	<p>Without</p> <p>Preinstalled, also provided on the Restore DVD and Microsoft Recovery CD</p> <ul style="list-style-type: none"> • Windows 2000 Professional MUI* • Windows XP Professional MUI* <p>*MUI: Multi-lingual user interface; German, English, French, Italian, Spanish, Japanese, Korean, Chinese simplified and Chinese traditional</p>

3.3 Accessories

The accessories comprise the following components:

Accessories	Comment	Order No.
Direct control key module		6AV7671-7DA00-0AA0
Film for protecting the touch screen panel against dirt and scratches for 15" touch screen variant for 19" touch screen variant		6AV7671-4BA00-0AA0 6AV7672-1CE00-0AA0
Film for labeling function keys (slide-in labels) ¹⁾		6AV7672-0DA00-0AA0
DVI / VGA adapter		A5E00254532
Backing plate for screw fixing of the 19" touch front		6AV7672-8KE00-0AA0
Multi IO module	Two parallel and two serial interfaces	6ES7648-2CA00-0AA0
SIMATIC PC DiagMonitor software V 2.2	Software for monitoring local and remote SIMATIC PCs: <ul style="list-style-type: none"> • Watchdog • Temperature • Fan speed • Hard disk monitoring, SMART • System monitoring, Ethernet monitoring: Heartbeat Communication: <ul style="list-style-type: none"> • Ethernet interface, SNMP protocol • OPC for integrating in SIMATIC software • Client server architecture • Layout of log files 	6ES7648-6CA02-2YX0
SIMATIC PC/PG Image & Partition Creator	Software for local data backup	6ES7648-6AA03-0YX0
Module for DDR RAM memory expansion	256 MB 512 MB 1 GB	6ES7648-2AG20-0GA0 6ES7648-2AG30-0GA0 6ES7648-2AG40-0GA0
Remote Kit order version Remote Kit, 24V DC, 5m Remote Kit, 24V DC, 10m Remote Kit, 24V DC, 20m Remote Kit, 24V DC, 30m Remote Kit, 120/230 V AC, 5m Remote Kit, 120/230 V AC, 10m Remote Kit, 120/230 V AC, 20m Remote Kit, 120/230 V AC, 30m		6AV7671-1EA00-5AA1 6AV7671-1EA01-0AA1 6AV7671-1EA02-0AA1 6AV7671-1EA03-0AA1 6AV7671-1EA10-5AA1 6AV7671-1EA11-0AA1 6AV7671-1EA12-0AA1 6AV7671-1EA13-0AA1

For further accessories, see Catalog or Siemens MALL

1) You can also find the print templates for the slide-in labels on the Internet at: <http://www.siemens.com/asis>

At *Tools & Downloads>Downloads>Produkt Support>Industrie-PC*, enter the entry ID 8782947.

Description

3.3 Accessories

Application planning

4.1 Overview

Introduction

This section describes the first steps after unpackaging, the permitted mounting positions and the fixation. This section describes the necessary considerations for EMC.

Field of application

The Panel PC is an industry-standard PC platform for demanding tasks in the field of PC-based automation. The Panel PC is designed for on-site use on the machine, installed for example in:

- Switchgear cabinet installation
- Swivel arm installation
- Rack installation

Note

In the following, the term "switchgear cabinet" also refers to rack, mounting rack, switchboard, operator panel and console. The term "device" represents the Panel PC and its variants.

4.2 Unpacking and checking the delivery

Procedure

1. Please check the packaging material for transport damage upon delivery.
2. If any transport damage is present at the time of delivery, lodge a complaint at the shipping company in charge. Have the shipper confirm the transport damage immediately.
3. Unpack the device.

Caution

Do not lie the device on its back. This will avoid any damage to an optical drive which may be present. Lie the front side on a soft surface to avoid damaging the front panel USB port.

4. Keep the packaging material in case you have to transport the unit again.

Notice

The packaging protects the device during transport and storage. Therefore, never dispose of the original packaging material!

5. Please keep the enclosed documentation in a safe place. You will need the documentation when you start up the device for the first time.
6. Check the package contents for completeness and any visible transport damage. Check for completeness using the enclosed scope of delivery list.
7. Should the contents of the package be incomplete or damaged, please inform the responsible supply service immediately and fax us the enclosed form "SIMATIC IPC/PG quality control report".



Warning

Make sure that a damaged device is not installed nor put into operation.

8. Note the identification information as described in the chapter "Identification data of the device".

4.3 Device identification data

Procedure

1. Write down the Microsoft Windows Product Key of the Certificate of Authenticity COA in the table at the end of this section. The COA label is only present in preinstalled Windows 2000 Professional or XP Professional and is affixed to the back of the device. You will need the product key during the reinstallation of the operating system.



Figure 4-1 COA label, example

2. Write down the manufacturer's number SVP and the order number, for example "6AV...", and enter it in the table. If repairs are necessary, the device can be identified by the service center on the basis of the SVP number and order number.

Both numbers are located on the rating label on the computer unit at the top of the fan side.

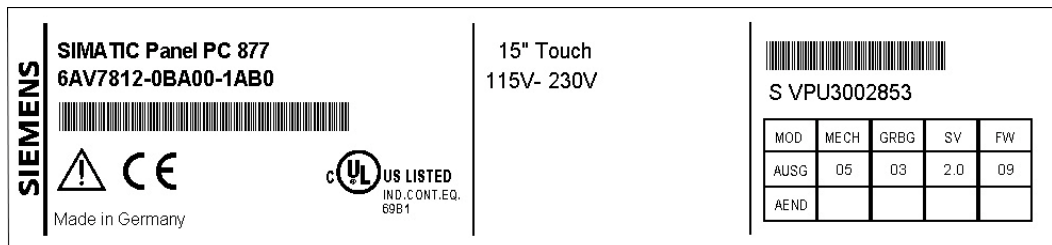

Figure 4-2 Panel PC 877 rating plate, example

3. Enter the Ethernet address of the device: The Ethernet address is located in the "Main" menu of the BIOS setup, "Hardware Options > Ethernet Address."

Identification	Number
1	Microsoft Windows Product Key COA
2	SVP number
3	Order number of the device
4	Ethernet address

4.4 Mounting Positions and Fastening

4.4.1 Installation guidelines

Before installing the device, read the following general notes relating to installation.



Warning

Danger, high voltage

Isolate the power supply to the switchgear cabinet before opening it. Ensure that the power to the switchgear cabinet cannot be turned on accidentally.

Caution

The device is approved for operation in closed rooms only.

- Ensure that the protective contact socket of the building installation is easily accessible and that there is a mains disconnect switch in switchgear cabinet installations.
- Position the screen in an ergonomic position favorable to the user. Choose a suitable installation height.
- Position the screen so that it is not subject to direct sunlight or other strong sources of light.
- Optical drives are susceptible to shock. Shocks during operation can lead to the loss of data or damage to the drive or data carrier. Optical drives are not only suitable for continuous operation.
- Applies to devices which are installed in swivel arm housings: Avoid rapid or jerky movements of the swivel arm during operation. The ensuing forces could lead to possible irreversible damage of the hard disk.
The stops of the swivel arm must be damped in order to avoid any mechanical shock effect to the Panel PC on attachment.
- Applies to devices which are installed in cabinet doors: Prevent the doors being slammed shut. The ensuing forces could lead to possible irreversible damage of the hard disk.
- The device with DC power supply applies in the area of the computer unit and above all the power supply connection in accordance with the UL approval as "open type" or "open equipment". For this reason, the device must be installed in a control cabinet or housing that complies with fire-proofing requirements

Note

The computer unit with AC power supply satisfies fire protection requirements to EN60950-1. It may therefore be installed without additional fire-proofing measures.

- Provide adequate volume in the switchgear cabinet for air circulation and heat transport. Keep at least 10 cm distance between the device and switchgear cabinet.
- Ensure that the maximum air intake temperature, measured 10 cm before the air intake opening on the fan, does not exceed 45°C. The maximum air intake temperature must be accounted for especially when sizing closed switchgear cabinets.
- The minimum distance between the device and the housing is 10 cm on the air output side at the fan.
- Position the device in such a way that the air vents of the housing are not covered up following mounting.
- Ensure there is enough free space in the switchgear cabinet to allow the sheet metal cover to be removed. You will otherwise have to remove the device from the switchgear cabinet or swivel arm when replacing memory or the battery.
- Provide enough free space to add on to the device.
- Equip the switchgear cabinet with struts for stabilizing the mounting cut-out. Install struts where necessary.
- Avoid extreme environmental operating conditions. Protect your device against dust, moisture and heat.
- Install the device in such a way (see Chapter *Technical specifications*) that it poses no danger, e.g. by falling over.
- During assembly, please comply with the approved installation positions.

Notice

If you mount the device in an impermissible installation position or you do not observe the environmental conditions (see Chapter *Technical specifications*), you endanger the product safety provided by the UL-approval and compliance with the low-voltage directive (via EN 60950-1). In addition, the functionality of the device is no longer guaranteed.

For additional information, refer to the dimension diagrams in the appendix.

4.4.2 Permitted mounting positions

Approval

Certain mounting positions are approved for the equipment that comprises one control unit and one computer unit.

Permitted mounting positions

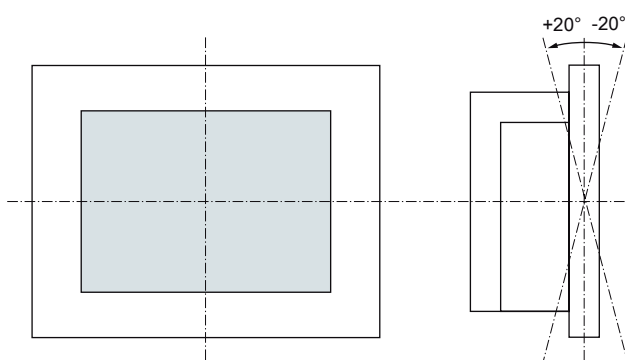

Vertical installation with deviations between $+20^\circ$ and -20° in the given directions is permissible.

4.4.3 Type of fixation

The computer unit is secured in the mounting cut-out either with clamps or screws.

Select the type of fixation suitable to your requirements for the degree of protection (see Section *Protection against dust and water*) .

4.4.4 Protection against dust and water

Principle

The degree of protection provided at the front is assured when the mounting seal lies completely against the mounting cut-out.

Caution

Please ensure that the material strength at the mounting cut-out is a maximum of 6 mm. Please follow the specifications for the dimensions in the "Mounting cut-out" section.

The degrees of protection are only guaranteed when the following is observed:

- The material strength at the mounting cut-out is at least 2 mm.
 - The surface plane deviation of the mounting cut-out in relation to the external dimensions of the control unit amounts to ≤ 0.5 mm when the control unit is mounted.
-

IP65 degree of protection and NEMA4

IP65 degree of protection and compliance with the NEMA4 regulations are only ensured when clamp mounting together with a ring seal.

IP54 degree of protection

This degree of protection is achieved for screw fixing of all operator control units with a key front panel and the 15" and 19" operator control units with a touch front panel. This degree of protection is assured for the 19" operator control unit with a touch front panel when the mounting components for 19" rack accessories are used.

Note

For screw fixing of the 19" touch panel front, a backing plate is available as an accessory. For further information, see "<http://mall.ad.siemens.com/>".

4.5 Mounting cut-out

4.5.1 Preparing the mounting cut-out

The following illustration show the dimensions for the mounting cut-out.

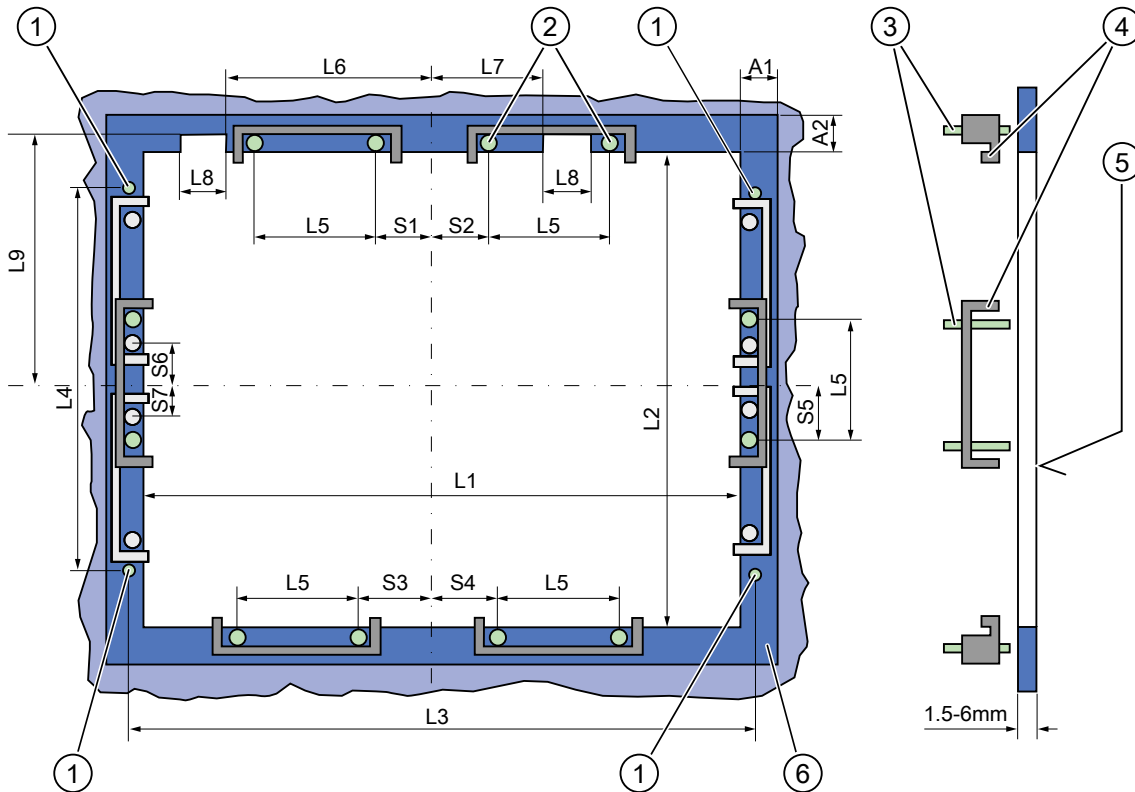

Figure 4-3 Drill holes for the screws and pressure points for the clamp screws

- | | |
|-------------------------------------|---|
| (1) Drill hole for screw attachment | (4) Clamp |
| (2) Pressure points for clamp | (5) R _z 120 in the seal area |
| (3) Setscrews | (6) Seal area |

Note

Installed dimensions can be read from the dimension overview or they can be transferred to the cabinet from the mounting template supplied.

Table 4-1 Dimensions for the mounting cut-out in mm

Control unit	L1	L2	L3 ¹⁾	L4 ¹⁾	L5	L6 ²⁾	L7 ²⁾	L8 ²⁾	L9 ²⁾	A1	A2	S1	S2 S3 S4	S5 ³⁾	S6 ³⁾ S7 ³⁾
Tolerance	+1	+1	±0.2	±0.5	±0.5	±0.5	±0.5	+1	±1	±1	±1	±1	±1	±1	
Key panel															
12" TFT	450	290	465	235	112	—	—	—	—	16	10	78	78	56	—
15" TFT	450	321	465	279	112	186	135	25	165	16	17	51	51	56	—
Touch panel															
15" TFT	450	290	465	235	112	—	—	—	—	16	10	81	81	56	—
19" TFT	450	380	465	235	112	—	—	—	—	16	10	46	46	—	33

1) M6 thread or drilled holes of 7 mm diameter

2) Cut-outs for the slots or inserted labels are required for 15" key panels only

3) Two clamps are required vertically for clamp mounting for the 19" touch panels only

Preparing the mounting cut-out

Steps for preparing the mounting cut-out	
1	Select a location suitable for mounting, taking into account the mounting position.
2	On the basis of the dimension diagrams, check whether the required screw and pressure points on the rear and the seal area are easily accessible after the completion of the mounting cut-out. Otherwise the mounting cut-out is useless.
3	Complete the mounting cut-out in accordance with the dimensions.

4.5.2 Mounting depth of the device

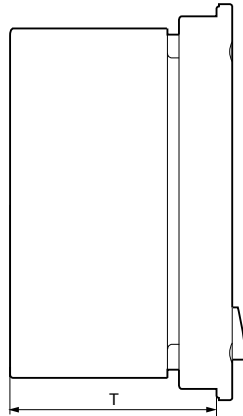

Panel PC with operator units	T
Key panel with 12" TFT	192 mm
Key panel with 15" TFT	211 mm
Touch panel with 15" TFT	209 mm
Touch panel with 19" TFT	217 mm

Note

Additional mounting depth with optical drive

The installation depth increases by 21 mm when an optical drive is installed in the device.

4.6 EMC directive

Electromagnetic compatibility

The device fulfills the requirements of the EMC law of the Federal Republic of Germany as well as the EMC directive of the Single European Market.

The device is designed as a built-in device. You ensure compliance with the EN 61000-4-2 (ESD) EMC standard by installing the device in grounded metal cabinets (e.g. 8 MC cabinets, Siemens catalog NV21).

Note

For additional information about EMC requirements, refer to the Specifications section.

Installing the device according to EMC directive

Basics for interference-free operation:

- Install the controller according to EMC directive
- Use interference immune cable

Note

The instructions "Guidelines for the assembly of interference immune programmable logic controllers" with the article ID 1064706 and the manual "PROFIBUS networks" with the article ID 1971286, which also applies to the installation of the device, is located on the "Documentation and Drivers" CD.

Installation

5.1 Securing the device with clamps

You require 6 clamps in order to mount the device with a 12"/15" display. A device with a 19" display must be mounted with 8 clamps. The required number of clamps is included in your Panel PC delivery package.

Required tool for fastening the clamps: 2.5 mm hexagonal spanner



Figure 5-1 Clamp assembly

Rack installation

Steps for fastening the device with clamps	
1	Disconnect the device from the power supply.
2	Working from the front, insert the device into the 19" rack.
3	Fasten the control unit in the rack from the rear using the clamps. Tighten the setscrews to a torque of 0.4-0.5 Nm.

Swivel arm installation

Steps for fastening the device with clamps	
1	Disconnect the device from the power supply.
2	Working from the front, place the device onto the swivel arm.
3	Fasten the control unit on the swivel arm from the rear using the clamps. Tighten the setscrews to a torque of 0.4-0.5 Nm.

Switchgear cabinet installation

Steps for fastening the device with clamps	
1	Disconnect the device from the power supply.
2	Working from the front, insert the device into the mounting cut-out.
3	Secure the control unit in the mounting cut-out from behind with the clamps, as shown in the mounting cut-out in the dimensions. Tighten the setscrews to a torque of 0.4-0.5 Nm.

IP 65 degree of protection

The plant builder is responsible for the correct installation of the device.

The degree of protection IP65 is only guaranteed for the front of the device if the ring seal is properly applied with the correct size of cutout, the unit has been clamped in place, and the instructions below are observed.

Notice

Control cabinet installation; Material strength at the mounting cut-out

Please ensure that the material strength at the mounting cut-out is a maximum of 6 mm. Please follow the specifications for the dimensions in the "Preparing the mounting cut-out" section.

The degree of protection can only be guaranteed when the following requirements are met:

1. The material strength at the mounting cut-out must be at least 2 mm.
 2. The deviation from the plane in relation to the external dimensions for an installed HMI device is ≤ 0.5 mm
-

5.2 Securing the device with screws

Note

To secure the 19" front panel with screws, backing plates with Order No. 6AV7672-8KE00-0AA0 are required on the front.

Drilling holes

Steps for drilling holes	
1	Drill holes (Ø approx. 2.5 mm) from the rear in the 4 recesses of the control unit. 
2	Use a Ø 5.5 mm bit for M5 and a Ø 6.5 mm bit for M6
3	Deburr the holes from the front of the control unit

Notice**Risk of damage**

Ensure that no metal cuttings enter the device when the holes are drilled. Cover the device with film or when drilling, use removal by suction.

Rack installation

Steps for fastening the device with screws	
1	Make drill holes at the prepared mounting cut-out in accordance with the specifications for L4 and L5, as shown at the dimensions in the mounting cut-out
2	Working from the front, insert the device into the 19" rack
3	Secure the control unit by inserting suitable screws through the holes and attaching nuts

Swivel arm installation

Steps for fastening the device with screws	
1	Make drill holes at the prepared mounting cut-out in accordance with the specifications for L4 and L5, as shown at the dimensions in the mounting cut-out
2	Working from the front, place the device onto the swivel arm
3	Secure the control unit by inserting suitable screws through the holes and attaching nuts

Switchgear cabinet installation

Steps for fastening the device with screws	
1	Make drill holes at the prepared mounting cut-out in accordance with the specifications for L4 and L5, as shown at the dimensions in the mounting cut-out
2	Carefully drill the respective holes in the control unit at the designated location from the rear
3	Working from the front, insert the device into the mounting cut-out
4	Secure the control unit by inserting suitable screws through the holes and attaching nuts

IP 54 degree of protection

The IP54 degree of protection is guaranteed for screw mounting together with the ring seal.



Caution**Observe the panel seal when mounting**

Ensure you do not damage the panel seal when mounting the device.

Notice**Control cabinet installation; Material strength at the mounting cut-out**

Please ensure that the material strength at the mounting cut-out is a maximum of 6 mm. Please follow the specifications for the dimensions in the "Preparing the mounting cut-out" section.

The degree of protection can only be guaranteed when the following requirements are met:

1. The material strength at the mounting cut-out must be at least 2 mm.
 2. The deviation from the plane in relation to the external dimensions for an installed HMI device is ≤ 0.5 mm
-

Connecting

6.1 Connection and operator control components

Connection and operator control components of the computer unit

Connection and operator control components of the left-hand side of the device		
Item	Name	Description
(1)	PCI / ISA	5 slots for PCI/ISA expansion modules
(2)	LPT 1	Parallel interface 25-pin Sub-D socket
(3)	DVI/VGA	DVI/VGA socket for CRT or LCD monitor with DVI interface or VGA monitor via DVI/VGA adapter
(4)	PS/2	Mouse connection
(5)	Reset button	-
(6)	PS/2	Keyboard connection
(7)	COM 2	Serial interface 9-pin Sub-D connector
(8)	USB	2 USB 2.0 connections high current (500 mA)
(9)	Ethernet	RJ45 connection for 10/100 Mbit/s
(10)	PROFIBUS/MPI /DP	MPI interface (RS485 electrically isolated) 9-pin Sub-D connector
(11)	COM 1	Serial interface 25-pin Sub-D connector

Reset button

The Reset key can trigger the following function during active operation:

Hardware reset: Immediate shutdown of the device without correct shutdown of the operating system

This function is used to shut down the device when it no longer responds. This triggers a hardware reset. Press the key briefly with a pointed object. Following a hardware reset, the device automatically boots up.



Caution

Data loss

A hardware reset can result in a loss of data.

Connection and operator control components of the right-hand side of the device

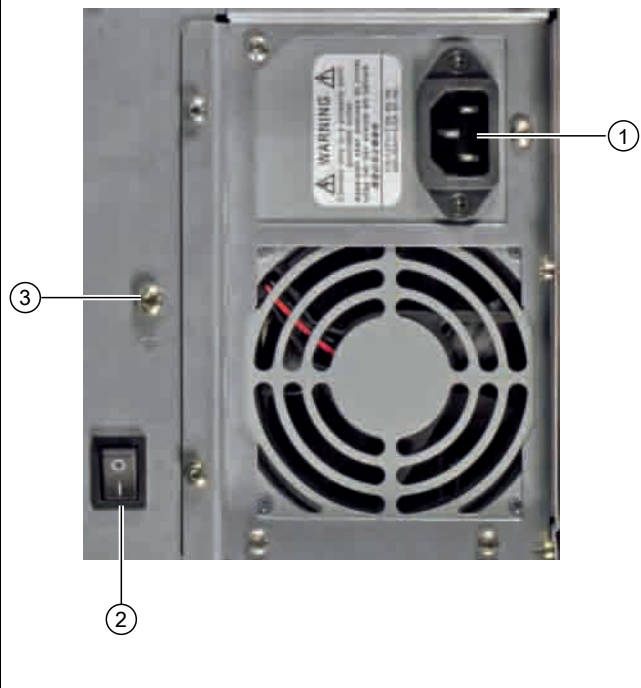
	Item	Name	Description
	(1)	100 / 240 V AC or 24 V DC	Connection for AC or DC power supply (depending on the product variant, the figure shows the AC power plug) The relevant angle is included with the device for interlocking the connector.
	(2)	On / Off switch	-
	(3)	Equipotential bonding	Connection for low-resistance grounding connection

Notice

On / Off switch

The On / Off switch does not disconnect the device from mains. When the switch is in 0 position, the device is still connected to the auxiliary voltage.

Connection components of the control unit

USB connection control unit			
	Item	Name	Description
	(1)	USB	1 connection USB 2.0 high current (500 mA) under sealing flap (not available with every product variant).

Notice

Guarantee for the IP 65 degree of protection

When the sealed cover over the USB interface is removed in order to connect a USB component, the IP 65 degree of protection for the device is no longer guaranteed.

Note

Use of USB devices

- Wait at least 10 seconds between the unplugging and replugging of USB devices. This also applies in particular to touch control in control units with touch screen panels.
- When using standard USB peripherals, bear in mind that their EMC immunity level is frequently designed for office applications only. These devices may be used for commissioning and servicing. However, only industry-standard devices are allowed for industrial operation.
- Peripherals are developed and marketed by individual vendors. The respective manufacturers offer support for the peripherals. Moreover, the terms of liability of the individual vendors or suppliers apply here.

6.2 Connecting the 100 V to 240 V AC power supply

General connection information

Note the following in order to operate the device safely and according to regulation:

Note

Voltage range

The power supply module is designed for operation on 100 to 240 V AC networks. The device adjusts automatically to the voltage.

Notice

Risk of damage

Do not connect or disconnect power and data cables during thunderstorms.

Notice

Power supply network

The device is designed for operation on grounded power supply networks (TN systems to VDE 0100, Part 300, or IEC 60364-3).

It is not permissible for operation on ungrounded or impedance-grounded power networks (IT networks).

Notice

Permitted mains voltage

The local rated voltage must be within the voltage range of the device.

Notice

Power disconnection

The built-in switch does not disconnect the device from mains. The mains connector on the device must be disconnected to fully isolate the device from mains. The mains connector must be easily accessible.

If this cannot be guaranteed, in cabinet installation, for example, or the mains connector clamp is used, an easily accessible power switch **must** be built into the device.

Power Factor Correction

The power supply contains an active PFC (Power Factor Correction) circuit to conform to the EMC guidelines.

Uninterruptible AC power systems (UPS) must supply a sinusoidal output voltage in the normal and buffered mode when used with SIMATIC PCs with an active PFC.

UPS characteristics are described and classified in the standards EN 50091-3 and IEC 62040-3. Devices with sinusoidal output voltage in the normal and buffered mode are identified with the classification "VFI-SS-...." or "VI-SS-....".

Notice

Risk of damage

Operation of the device on a non-sinusoidal mains voltage can cause damage to the power supply unit.

Country-specific connection information

For the USA and Canada

A UL-listed power supply cable must be used in the United States and Canada. Power cables are provided as an accessory for the specific country of delivery.

- **120 V supply voltage**
Use a flexible power cable with UL approval and the following features: Type SJT with three leads, min. 18 AWG conductor cross-section, max. 4.5 m long and parallel 15 A ground contact connector, minimum rating 125 V.
- **230 V supply voltage**
Use a flexible power cable with UL approval and the following features: Type SJT with three leads, min. 18 AWG conductor cross-section, max. 4.5 m long and tandem 15 A ground contact connector, minimum rating 250 V.

For countries other than the USA and Canada

- **Please note local supply voltages**
This device is equipped with a safety-tested power cord which may only be connected to a ground contact power outlet. If you choose not to use this cable, you must use a flexible cable of the following type: Min 18 AWG conductor cross-section and 15 A / 250 V shockproof connector. The cable set must be compliant with the safety regulations and stipulated IDs of the country where the system is to be installed.

Connecting the power supply

Steps for connecting the device to the 100 / 240 V AC power supply	
1	Switch off the AC power source
2	Connect the power supply using the connector

Power consumption

The maximum AC power consumption is 360 W.

6.3 Connecting the 24 V DC power supply

General connection information

Note the following in order to operate the device safely and according to regulation:

Notice

Power supply

The device must only be connected to 24 V DC power supply systems or 24 V DC power supplies which meet the requirements of a safe extra-low voltage (SELV). Use the supplied connector to connect it to the supply voltage.

Notice

Connecting the protective conductor

A protective conductor must be connected to the device. The conductors must withstand the short-circuit current of the 24 V DC power source, so that a short-circuit will not damage the cable. You may use cables with a cross section of 5 mm².

Connecting the power supply

Steps for connecting the device to the 24 V DC power supply	
1	Ensure that the ON/OFF switch is in the '0' (OFF) position to prevent unintentional startup of the device when connecting it to the 24 V DC power supply
2	Switch off the 24 V DC power supply
3	Connect the 24 V DC power supply to the screw terminals: (1) +24 V DC (2) 0 V DC (3) protective ground conductor



Power consumption

The maximum DC power consumption is 265 W.

6.4 Connecting the equipotential bonding circuit

A low resistance ground connection ensures that interference signals generated by external power supply cables, signal cables or cables to the I/O modules are safely discharged to ground.

The equipotential bonding connection of the device is located on the right-hand side of the computer unit and is identified by the following symbol:



Figure 6-1 Equipotential bonding

Connecting the equipotential bonding circuit

You require a TORX T20 screwdriver to connect the equipotential bonding conductor.

Steps for connecting the equipotential bonding	
(1)	<p>Connect the equipotential bonding connection (M4 thread) (1) on the device (large surface, large-area contact) with the central grounding point of the control cabinet. The minimum permissible cross-section is 5 mm².</p> 

Integration into an automation system

7.1 Overview

Introduction

The following options are available for integrating the device in existing or planned system environments and networks.

Ethernet

The integrated Ethernet interface can be used for communication and for data exchange with automation devices such as SIMATIC S7.

You require suitable software for this: STEP7, WinCC, WinCC flexible, WinAC, SIMATIC NET.

PROFIBUS / MPI

The potentially isolated Profibus interface can be used to connect distributed field devices or to couple with SIMATIC S7.

You require suitable software for this: STEP7, WinCC, WinCC flexible, WinAC, SIMATIC NET.

Additional information

For further information, refer to the catalog and to the online ordering system of Siemens A&D.

Internet address: <https://mall.ad.siemens.com>

7.2 Device in a SIMATIC S7 configuration

7.2.1 MPI/PROFIBUS-DP network

You can connect the device to a SIMATIC S7 automation system or a PROFIBUS DP network via the MPI/DP interface. You can connect up to 32 PC, PG, or AS devices to one network segment. The use of repeaters allows you to interconnect several MPI/PROFIBUS DP network segments. The complete MPI/PROFIBUS DP network consists of a maximum of 127 stations.

The device is physically connected to the MPI/PROFIBUS DP network via an electrically isolated RS485 interface on the PC motherboard. The potential is isolated within the safety low voltage circuit (SELV).

The transmission rate is limited to 187.5 Kbps with the 5-meter MPI cable for connecting to the SIMATIC S7-CPU. To achieve baud rates over 1.5 Mbps, you require a 12 Mbps PROFIBUS cable with the order number 6ES7901-4BD00-0XA0. In the PROFIBUS DP MPI network, you can achieve data transmission rates of 9.6 Kbps to 12 Mbps.

7.2.2 Connecting an S7 automation system

Coupling

The device is coupled via the MPI/DP interface as follows:

- With MPI networks S7-200, S7-300, and S7-400
- PROFIBUS DP networks with DP components

Hardware requirements

You can use the following components for coupling or networking with PROFIBUS:

- RS 485 interface, MPI/DP interface, onboard
- PROFIBUS cable

Note

Refer to the SIMATIC Net catalog IK PI for more information about SIMATIC Net PC cards.

Procedure

1. Disconnect the device from mains.

Caution

Risk of damage to the device!

Neutralize the static charge of your body, the device, and the connecting cables. You can do this by briefly touching the metal housing with the cable in your hand.

2. Insert the PROFIBUS cable in the MPI/DP socket.
3. Reconnect the device to the electrical power system.

7.3 Networking via Industrial Ethernet

You can establish a network between the device and other computers via Industrial Ethernet. The on-board LAN is a Twisted-Pair (TP) interface for data transfer rates of 10/100 Mbit/s.

The interface is Plug and Play-ready and is automatically detected in Windows. Protocol settings are made in the Windows control panel.

Notice

A Class 5, CAT 5 Ethernet cable is required for 100 Mbit/s operation.

Commissioning

8.1 Overview

Checklist

Before starting up the device for the first time, go through the following checklist:

- Have you taken into account the proper ambient and environmental conditions for the device, as described in the Technical data?
- Have you learned how to connect the equipotential bonding?
- Have you learned how to connect the power supply?
- Read over this information in the respective "Connecting" chapter of the operating instructions. Please follow all guidelines.

Caution

Condensation

When transporting the device at low temperatures, ensure that no moisture gets on or into the device. This also applies if the device is subjected to extreme changes in temperature. Wait 12 hours before switching the device on.

Allow the device to slowly adjust to room temperature before commissioning the device. Do not subject the device to direct heat radiation from devices such as heaters.

Requirements

- The equipotential bonding is connected.
- The cables are correctly plugged in.

8.2 Switch on the device

Procedure

1. Plug the power plug of the supplied power supply cable in the AC/DC power supply connector of the computer unit.
2. Lock the power plug in place.
3. Plug the power supply cable of the computer unit into a socket with a grounded protective conductor.
4. Switch on the computer unit at the power switch.

The "POWER" LED will light up. The device starts up and boots.

Self Test

After connection to the power supply, the device performs a self test. During the self test, the message "Press F2 to enter SETUP" appears briefly.

When the self-test is finished, the operating system will be loaded.

8.3 Setting up the Microsoft Windows operating system

Introduction

The setup wizard appears immediately following the startup of the device. The wizard is used to set the parameters of the operating system.

Note

The dialogs of the setup wizards differ slightly in some places for the Windows 2000 Professional and Windows XP Professional operating systems.

In order to change to the next dialog, click on the ">>" button. In order to change the entry in the previous dialog, click on the "<<" button.

Procedure

1. Accept the Microsoft licensing agreement.
2. Leave the regional settings of the operating system unchanged. If required, adjust the regional settings of the operating system only after commissioning.
3. Enter the company names and user names.
4. If this PC name is already in use as you attempt to connect the device to a network: Enter a new PC name for identification.

The operating system will restart automatically.

The system settings are updated. The desktop is set up. The setup of the operating system is complete.

8.4 Installing applications and drivers

Introduction

After the device is restarted, different dialogs appear on the screen. Drivers and applications can be installed from these dialogs.

Additional hardware and software components

You can install and configure additional hardware and software components. For additional information, refer to the documentation of the hardware and software.

Note

The directory "c:\i386" contains special Windows components for subsequent installation.

Procedure

1. In the "Panel Wizard" dialog, click the type of panel that corresponds to your device.



Figure 8-1 Panel Wizard, selection of the panel type

When selecting the Touch Panel, proceed according to the section Set Touchscreen. To select the Key Panel, proceed as described in the section Set key fron.

Setting the touch screen

This step only applies to control units with touch screen panels.

2. In the following dialog, click on the screen size that corresponds to your device. You will find details of the screen size on the rating plate for the control unit. The display resolution of the device will be adjusted correspondingly.



Figure 8-2 Touch screen panel, selecting the screen size

3. Click on "Finish" to end the Panel Wizard.

Note

Screen keyboard

The check-box is activated by default. You enter the administrator password, for example, using a screen keyboard which appears at every Windows startup. An external keyboard is then not necessary.

If you deactivate the check-box, the screen keyboard does not appear. It will, however, be installed.



Figure 8-3 Touch screen panel, end Panel Wizard

4. New hardware, the touch controller, is found. In order to start the touch calibration, click on "OK". Carry out the following steps carefully:



Figure 8-4 Start touch screen calibration

5. Briefly touch the touch screen at every cross hair.
Continue from Point 7.

Setting the key panel

This section applies only to control units with key panels.

- Click on "Finish" to end the Panel Wizard.



Figure 8-5 Keyboard panel, end Panel Wizard

- Exit the operating system session and restart the device. Otherwise the "Security features" from "KeyTools" will not be activated.



Warning

Use "KeyTools" as described in the "Additional drivers and applications/KeyTools (for device with key front only)" section of the "Operation and configuration" chapter.

The following applies when the "Security features" of "KeyTools" is deactivated:

When the additional function keys F13 and S16 are used, or when using your own key code table, serious malfunctions of the user software can occur because the key codes behind the function keys can also be activated by activating keys other than the configured ones. Further information is available in the description of "KeyTools" on the supplied "Documentation and Drivers" CD.

- No administrator password is assigned in the factory state. When the logon dialog appears the next time the device starts up, therefore, leave the field empty and close the dialog with the "OK" button.

Notice

Then configure an administrator password for security.

The installation of the drivers and applications is complete. Further information is available in the "Operation and configuration" chapter in the section, "Additional drivers and applications."

Notice

After starting up your device, find out more about the particulars of the operating system in the chapter "Commissioning" in the section, "Microsoft Windows operating systems". Further information is available in the chapter "Service and maintenance" under the section, "Installing software."

8.5 BIOS settings

A USB keyboard is not fully available before Windows starts up. There are not restrictions to using a USB keyboard when editing the BIOS. To be able to select a boot menu before Windows starts, however, connect a PS/2 keyboard.

Caution

Activate the "USB legacy Keyboard/Mouse" feature only when a USB keyboard or mouse is connected. A requirement for activation is that "USB BOOT" <enable> has been selected in the BIOS.

Note

To edit the BIOS on the operator device with a touchscreen, connect a USB keyboard or an external PS/2 keyboard.

8.6 Microsoft Windows operating system

8.6.1 Enables

The device is approved for use with the following operating systems:

Approvals

- Windows 2000 Professional Multi-Language SP4 and higher, German, English, French, Italian, Spanish, Japanese, Korean, Chinese Simplified and Chinese Traditional
- Windows XP Professional Multi-Language, German, English, French, Italian, Spanish, Japanese, Korean, Chinese Simplified and Chinese Traditional

Windows XP Professional is only approved as of Service Pack 2.

The operating system is provided with the Windows function modes "Hibernate" and "Standby" deactivated when shutting down the operating system and with "Fast User Switch" (Windows XP Professional) deactivated.

8.6.2 Windows 2000 Professional

Restrictions

Notice

If you have an external PS/2 keyboard and a USB keyboard connected at the same time, the keyboard LEDs on the external keyboards may not be correctly refreshed in some circumstances.

Service pack

After a new installation of Windows 2000 Professional, install at least Service Pack 4. Service Pack 4 is supplied in the product package.

Note

If you are using SIMATIC WinCC or SIMATIC WinCC flexible, pay heed to the operating system releases. For additional information, refer to the SIMATIC WinCC and SIMATIC WinCC flexible documentation.

Automatic logon

When automatic logon is used, a defined user is automatically logged on with a defined password. No logon dialog appears when the operating system starts up. For additional information, refer to the Windows help.

Call

Start menu "Start", command "Settings > Control panel > Automatic Updates"

You can deactivate this function in the dialog "Automatic Updates" "Keep my computer up to date. With this setting enabled,

Updates will then no longer be performed automatically on the device via the Internet.

Notice

When the check-box is activated, updates will be installed automatically on the device via the Internet even when they have not been released by Siemens AG.

8.6.3 Windows XP Professional

Restrictions

Note

If you have an external PS/2 keyboard and a USB keyboard connected at the same time, the keyboard LEDs on the external keyboards may not be correctly refreshed in some circumstances.

Service Pack

After a new installation of Windows XP Professional, install at least Service Pack 2. Service Pack 2 is supplied in the product package.

Note

If you are using SIMATIC WinCC or SIMATIC WinCC flexible, pay heed to the operating system releases. For additional information, refer to the SIMATIC WinCC and SIMATIC WinCC flexible documentation.

Automatic logon

When automatic logon is used, a defined user is automatically logged on with a defined password. No logon dialog appears when the operating system starts up. For additional information, refer to the Windows help.

Call

Start menu "Start", command "Settings > Control panel > Automatic Updates"

You can deactivate this function in the dialog "Automatic Updates" "Keep my computer up to date. With this setting enabled,

Updates will then no longer be performed automatically on the device via the Internet.

Notice

When the check-box is activated, updates will be installed automatically on the device via the Internet even when they have not been released by Siemens AG.

8.7 USB

Introduction

Commercially available USB peripherals can be easily and flexibly connected via the USB interface. For example, you can connect an external USB keyboard and a USB mouse. If the USB keyboard has a USB interface, you can connect other USB peripherals, such as a USB mouse, directly to the keyboard.

USB interface

There are several types of USB peripherals:

- Low power devices: maximum 100 mA power consumption, e.g. mouse and keyboard
- High power devices maximum 500 mA power consumption, e.g. hard disk and floppy drive

Note

The general USB specifications apply to the USB interfaces on the computer unit.

The USB interface on the front panel has been approved for a maximum of one additional USB hub.

Using USB peripherals

Notice

When installing a USB device for the first time, make sure you have the required device driver.

Before removing an intelligent USB device, deactivate the device in the operating system using the dialog "Unplug or Eject Hardware". For additional information, refer to the documentation for the operating system.

Operation and configuration

9.1 Normal operation

9.1.1 Switch on the device

Requirements

- The peripheral devices are connected.

Caution

To comply with the EMC guideline of the device with I/O, ensure that the manufacturer or supplier of the components used guarantees compliance with the regulations. Connect the I/O devices via shielded cables with metal connectors. In doing so, the shield must be connected over a wide area with the metal connector and the connector must be firmly connected with the device housing.

- The operating system and the service packs have been installed and set up on the hard disk of the device. Refer to the "Commissioning" chapter for more information.
- The pre-installed drivers and applications have been set up appropriately. Further information is available in the "Operation and configuration" chapter in the section, "Additional drivers and applications."
- The proper ambient and environmental conditions according to the specifications for the device and the connected I/O modules have been observed.

Procedure



Warning

Danger of incorrect operations!

The following applies to external input devices or combinations of external input devices and control units with key panels: Ambiguous key codes can cause serious malfunctions of the application program.

Always activate the "Security features" of "KeyTools." Please note the applicable safety information in the "Operation and configuration" chapter in the section, "Additional drivers and applications."

Caution

The device must not be switched on if there is condensation. Switch it on only after it has been stored in a (heated) room for at least 12 hours for temperature adjustment.

9. Connect the AC device to a socket with protective conductor with a cable suitable for the application. You connect the DC device to your 24 V DC power supply using the supplied special connector.
10. Switch on the power switch of the device.
The "POWER" LED will light up. The device is now in operation and booting.

Caution

Risk of data loss!

Do not switch off the power supply when the device is in operation. Disconnect the power only after the device has been correctly shut down.

After switching on the power supply, the device performs a self-test. During the self-test, the message "Press <F2> to enter SETUP" appears briefly.

When the self-test is finished, the operating system will be loaded and the desktop will be displayed.

The booting process has been completed successfully.

9.1.2 Logging on to the operating system via the onscreen keyboard (OSK)

The logon dialog is displayed when you have assigned an administrator password.

Note

A screen keyboard appears for devices with touch screen panels. You can enter the administrator password directly on the touch screen using the screen keyboard or using the mouse. For additional information, refer to the Microsoft help on screen keyboards.

9.1.3 Switching off the device

Introduction

To turn off the device, shut it down and disconnect the device from the power supply.

Procedure

1. Exit the operating system session of the device properly.

Caution

When using the operating systems Windows 2000 Professional and Windows XP Professional, wait until the display has turned dark.

2. Switch the device off using the On/Off switch.
3. In order to isolate the power supply completely, turn off the power at the power supply switch and pull out the plug from the device.



Warning

Always pull out the plug to isolate the device from the mains.

In the case of the direct key module, make sure the keys of the membrane keyboard that are configured as direct control keys remain operable until the voltage of the entire device has been switched off.

9.2 Additional Drivers and Applications

9.2.1 Overview

The necessary drivers and applications are contained in the supplied "Documentation and Drivers" CD.

Note

The supplied drivers and applications have been system-tested and are approved for this device. No warranty can be provided for other software.

Press the "Help" button to obtain information concerning the buttons of a dialog.

9.2.2 Calibrating the touch screen, UPDD

Call

- Start menu "Start", command "Programs > UPDD > Settings"

Function

Recalibrates the touch screen.

If the touch screen does not react as expected when touched, repeat the calibration. To do this, first activate the 25 point calibration and then calibrate the touch screen.

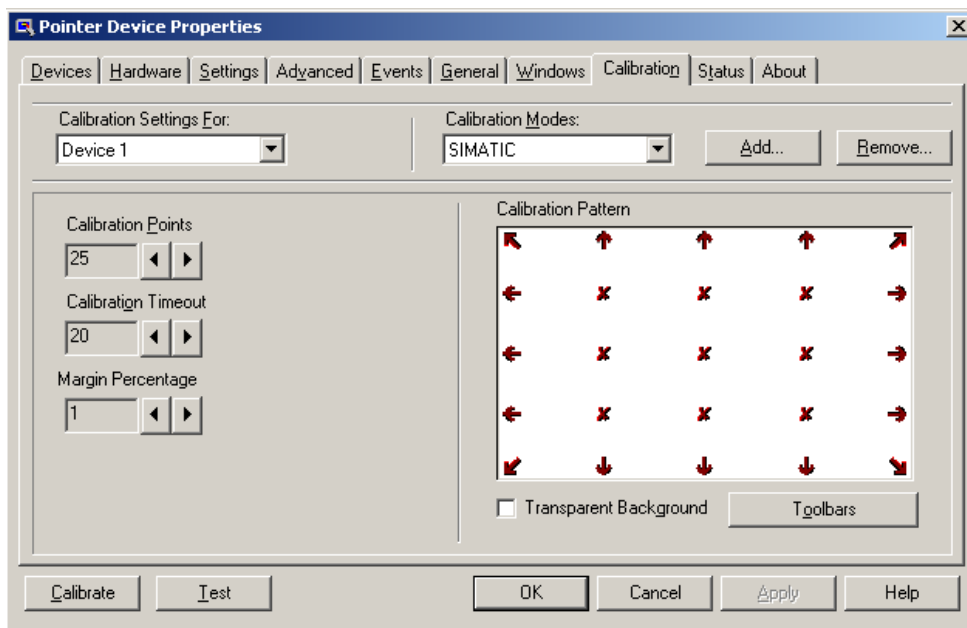

Figure 9-1 25-point calibration

Note

For further information press the "Help" button.



Warning

Maloperation

If you touch the touch screen while the screen saver is active, the SIMATIC process visualization software, e.g. WinCC, will carry out the functions which happen to be behind it.

Caution

Only touch one point on the touch screen and not several points at one time. You may otherwise trigger unintended reactions.

Do not touch the screen in the following situations:

- When the device is booting until the boot process is completed
 - When plugging or unplugging USB components
 - While Scandisk is running
-

9.2.3 Enable/disable touch functionality

The procedure for deactivating and reactivating the touch functionality using the "UPDD" software is described in the table below.

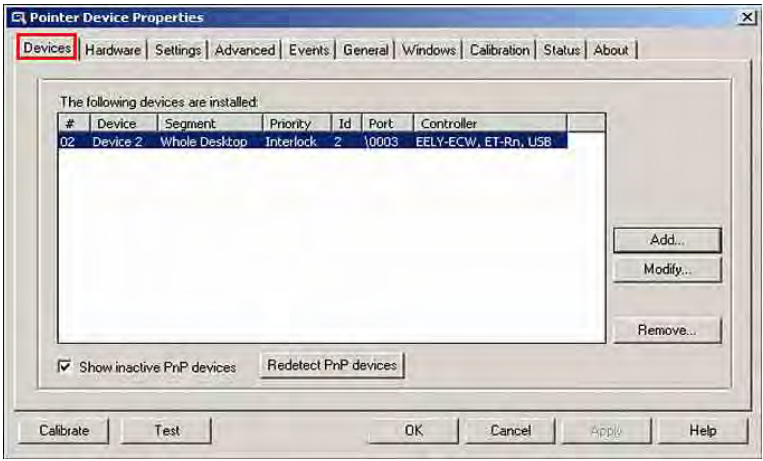
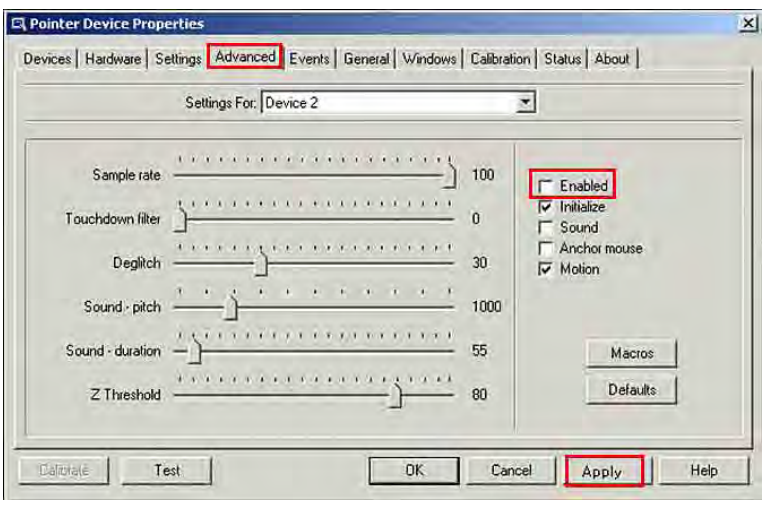
No.	Procedure															
1	Open the Control Panel menu in the Windows operating system															
2	Open the properties of the "Pointer Device" application in the Control Panel to access the "Pointer Device Properties" dialog.															
3	In the "Devices" tab in the "Pointer Device Properties" dialog, there is a list of devices (also known as DCUs). As shown in the figure, mark the device 02 or the active touch controller of the system and open the "Advanced" tab.	 <p>The following devices are installed:</p> <table border="1"> <thead> <tr> <th>#</th> <th>Device</th> <th>Segment</th> <th>Priority</th> <th>Id</th> <th>Port</th> <th>Controller</th> </tr> </thead> <tbody> <tr> <td>02</td> <td>Device 2</td> <td>Whole Desktop</td> <td>Interlock</td> <td>2</td> <td>\0003</td> <td>EELY-ECW, ET-Rn, USB</td> </tr> </tbody> </table> <p>Buttons: Add..., Modify..., Remove... <input checked="" type="checkbox"/> Show inactive PnP devices Redetect PnP devices Calibrate Test OK Cancel Apply Help</p>	#	Device	Segment	Priority	Id	Port	Controller	02	Device 2	Whole Desktop	Interlock	2	\0003	EELY-ECW, ET-Rn, USB
#	Device	Segment	Priority	Id	Port	Controller										
02	Device 2	Whole Desktop	Interlock	2	\0003	EELY-ECW, ET-Rn, USB										
4	In the "Advanced" tab, deactivate the "Enabled" option and load the settings by clicking the "Apply" button. The touch screen is now deactivated.	 <p>Settings For: Device 2</p> <p>Sample rate: 100 Touchdown filter: 0 Deglitch: 30 Sound - pitch: 1000 Sound - duration: 55 Z Threshold: 80</p> <p> <input type="checkbox"/> Enabled <input checked="" type="checkbox"/> Initialize <input type="checkbox"/> Sound <input type="checkbox"/> Anchor mouse <input checked="" type="checkbox"/> Motion </p> <p>Buttons: Calibrate Test OK Cancel Apply Help</p>														

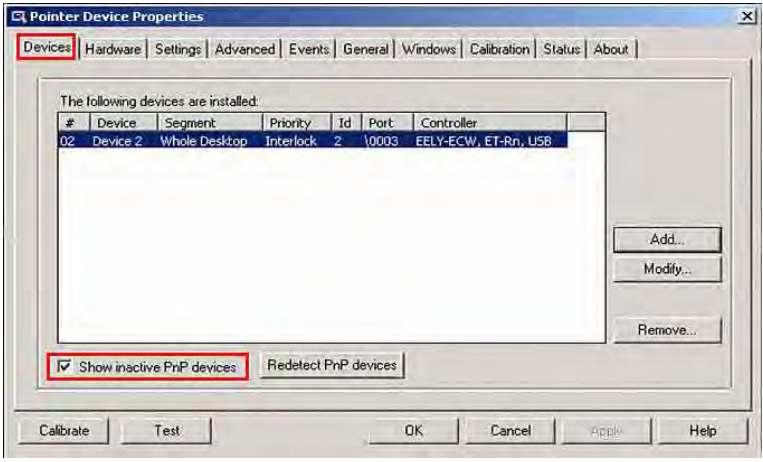
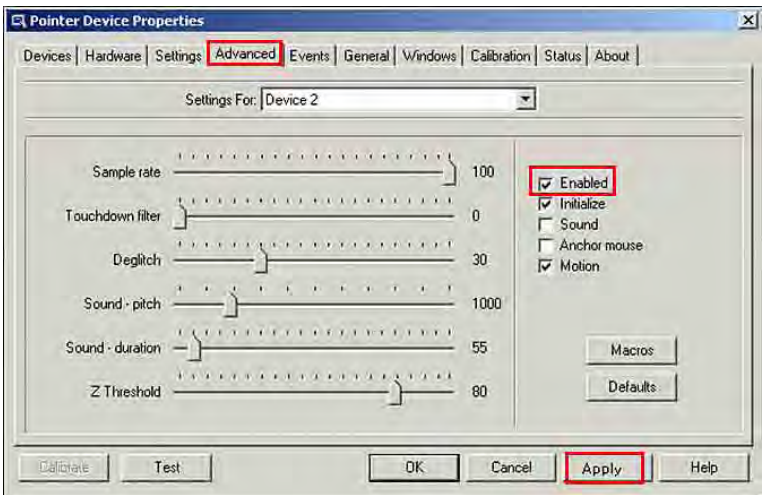
No.	Procedure	
5	To start up the touch functionality again, you must mark the corresponding touch controller in the "Devices" tab and activate the option "Show inactive PnP devices". Then select the "Advanced" tab again.	 <p>The screenshot shows the 'Pointer Device Properties' dialog box with the 'Devices' tab selected. A table lists installed devices, with 'Device 2' highlighted. Below the table, the 'Show inactive PnP devices' checkbox is checked and highlighted with a red box. The 'Advanced' tab in the top menu is also highlighted with a red box.</p>
6	In the "Advanced" tab, deactivate the "Enabled" option and load the settings by clicking the "Apply" button. The touch functionality is now activated again.	 <p>The screenshot shows the 'Pointer Device Properties' dialog box with the 'Advanced' tab selected. The 'Enabled' checkbox is checked and highlighted with a red box. The 'Apply' button at the bottom right is also highlighted with a red box.</p>

9.2.4 Windows Security Center (Windows XP Professional only)

Call

- Start menu "Start", command "Settings > Control panel > Security Center"

Function

The Windows Security Center has the following functions with the corresponding default settings: Activates and deactivates the following functions on the device:

Function	Default setting
Firewall	on
Automatic updates	off
Virus protection	off
Alarms	on

The default settings can be activated and deactivated.



Figure 9-2 Windows Security Center

Alarms

Click on "Change the way Security Center alerts me" to switch off security alarms upon switching on the device. The "Alert Settings" dialog appears. Deactivate the desired alarms.

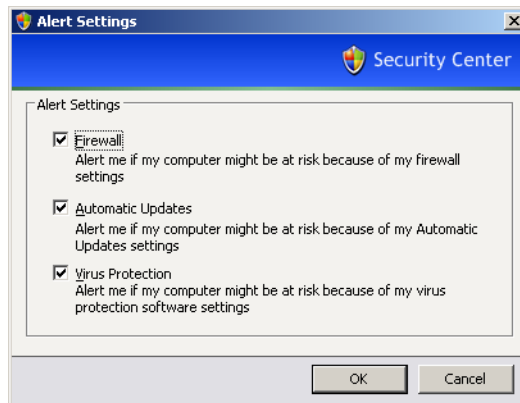

Figure 9-3 "Alert Settings" Dialog

9.2.5 KeyTools (for key panel devices only)

SIMATIC KeyTools is one selection of the applications for your Panel PC. These applications allow you to adapt key codes that are sent by the key panel of the control unit. SIMATIC KeyTools consists of the following tools:

- Key code table: Loading and editing of key code tables
- WinCC hotkey function: WinCC hotkey function activation and deactivation
- Security features: Lock function that prevents two function keys from being activated simultaneously. This prevents incorrect operations and undefined states of the application program.

Note

For a detailed description of the SIMATIC KeyTools please refer to the help menu and the application description on the "Documentation and Drivers" CD.

Calling up KeyTools

1. Call KeyTools using the "Start" menu and command "Settings > Control Panel > SIMATIC KeyTools"
2. Select the desired application and follow the instructions on the screen.

Note

See also the chapter on using the direct key module software control.

Notice

Malfunctions of the user software

For security reasons always use the "Security features". If you deactivate it nevertheless, serious malfunctions of the user software may occur when the additional function keys and softkeys F11 to F20 and S1 to S16 are used or if own key code tables are used.

9.2.6 Screen keyboard (for touch panel device only)

You can operate the device by means of a virtual screen keyboard. You can use it to enter the characters directly on the touch screen or with an externally connected mouse.

Calling up TouchInput

Call up the "TouchInput" application on the desktop. The screen keyboard is displayed.



- (1) Key for selecting the keyboard layouts for specific countries: German, English, Italian, Spanish, French

9.2.7 Setbrightness

Start

"Set brightness" symbol on the desktop.

Function

The intensity of the backlighting is adjusted using "Set brightness."



Figure 9-4 Setbrightness

9.2.8 CheckLanguageID

Scope

The following applies to Windows 2000 Professional Multi-Language and Windows XP Professional Multi-Language.

Call

c:\drivers\checklang\checklangid.exe or reinstallation from the "Documentation and Drivers" CD.

Function

"CheckLanguageID" displays the currently installed languages.



Figure 9-5 CheckLanguageID

- SystemDefaultLangID: System language
- UserDefaultLangID: Standard language
- UserDefaultUILangID: User interface language

Notice

All three languages displayed should have the same ID assigned.

9.2.9 Multilingual settings for the operating system

Windows MultiLanguage MUI operating system enables users to set the language of the GUI to their individual preference. Some elements are not localized, however, and remain in the original language of the system - English.

You should therefore always install English language service packs. Further information about the language of the GUI, regional settings and inputs is available on the Internet at <http://support.microsoft.com>.

Setting up the language selection for Windows 2000 Professional

The Multilanguage User Interface (MUI) allows you to set up the Windows 2000 Professional menus and dialogs for additional languages.

To set the required languages for the Windows 2000 Professional menus, dialogs and keyboard layout, select:

Start > Settings > Control Panel > Regional Options > General tab, Setting for current user field and Language settings for the system field and the Keyboard layout field in the Input locales tab.

In addition to the menu and dialog language settings, you also need to set the default language by selecting **Set Default...** from the **Regional Options** dialog box.

The default language setting of your Windows 2000 Professional installation is English and a US keyboard layout. To change to another language and keyboard layout, open the Control Panel and select:

Notice

If you use a different keyboard layout to "Englisch/USA international", the internal keyboard codes will no longer be correct.

Start > Settings > Control Panel > Regional Options > General tab, Setting for current user field and Language settings for the system field and the Input language field in the Input Locales tab.
--

Setting up the language selection for Windows XP Professional

The Multilanguage User Interface (MUI) allows you to set up the Windows XP Professional menus and dialogs for additional languages.

Default language of your Windows XP Professional MUI installation is English and a US keyboard layout. You can change the language in the Control Panel. Select:

Notice

If you use a different keyboard layout to "Englisch/USA international", the internal keyboard codes will no longer be correct.

Start > Control Panel > Date, Time, Language, and Regional Options > Add other languages > Languages tab, Language used in menus and dialogs field.

For the **Date, Time, Language and Regional Options** set the default as **non-Unicode programs** under **Advanced** in addition to the language for menus and dialogs.

9.2.10 DVD ROM/CD RW

The DVD-ROM/CD-RW drive is an optional feature. Recording methods supported by the disk drive: Disc at once, Track at once, Session at once, Packet writing, whereby Disc at once und Track at once are recommended due to their compatibility to other optical drives. DVD-ROM, CD-ROM, CD-R and Video CDs can be read.

Burner/DVD player software

To utilize the full functionality of our DVD-ROM/CD-RW drive, you need to install additional software (burning or DVD player software). This software is included on the CD supplied with the device. Insert the CD in the drive, run setup and follow the instructions on the screen.

Information on burning CD-Rs/CD-RWs

Caution

Data may be corrupted when burning CD-R or CD-RW!

Burning is permissible only in an undisturbed environment, i.e. shock and vibration stress must be avoided. Because of heavy fluctuation in the quality of CD-Rs, data may be corrupted in a burning session, even if no error message is initially displayed. The written data can only be verified by comparing these with the source. To be on the safe side, data should be verified after every burning session. When backing up an image, the data should be restored to the hard disk and the system should be rebooted from the hard disk.

9.2.11 USB keyboard controller

The USB keyboard controller supports the following additional functions for key models:

- Keyboard programming with the "KeyTools" application
- Adjustment of the backlighting brightness with the application "SetBrightness."
- Control of the key LEDs

The USB keyboard controller must be installed before this function can be used. For installation instructions, see the description on the "Documentation and Drivers" CD.

Operation

10.1 Status displays

The two LEDs on the upper left hand side of the front panel display the operating status:

- LED "POWER" green: Active voltage
- LED "TEMP" orange: The temperature threshold has been exceeded; the maximum value is preset and cannot be changed.

Refer to the "Functions" chapter for more information.

10.2 General control elements

On / Off switch

On / Off switch	Description
 A photograph of a white metal device panel. On the left side, there is a black rocker switch with a white 'I' symbol in the down position. To the right of the switch is a circular fan grille with several curved blades.	The On/Off switch does not disconnect the device from supply voltage. When the switch is in 0 position (Off), the device is still connected to the auxiliary voltage.



Warning

The On/Off switch does not disconnect the device from supply voltage.

Reset button

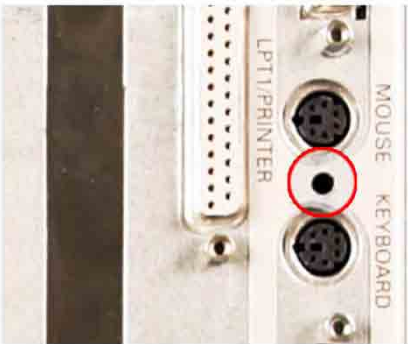
Reset button	Description
 A close-up photograph of a device panel's rear panel. It shows several ports: an LPT1/PRINTER port, a MOUSE port, and a KEYBOARD port. A small circular reset button is located between the MOUSE and KEYBOARD ports and is circled in red.	The reset button can be actuated with a pin or an opened up paper clip, for example. The button signal triggers a hardware reset. The PC performs a restart (cold start).

Caution

Data may be lost when the PC performs a hardware reset!

10.3 Device with key panel

The device has the following keypads:

- 2 x 8 vertical keypads with softkey functions
- 2 x 10 horizontal keypads with function keys F1 -F20

The number of keys, their labeling and function is the same on all key panels. The various panel types differ only in the arrangement of the keys and in the size and type of the display. The following figure is therefore only an example using the front view of the 12" variant.

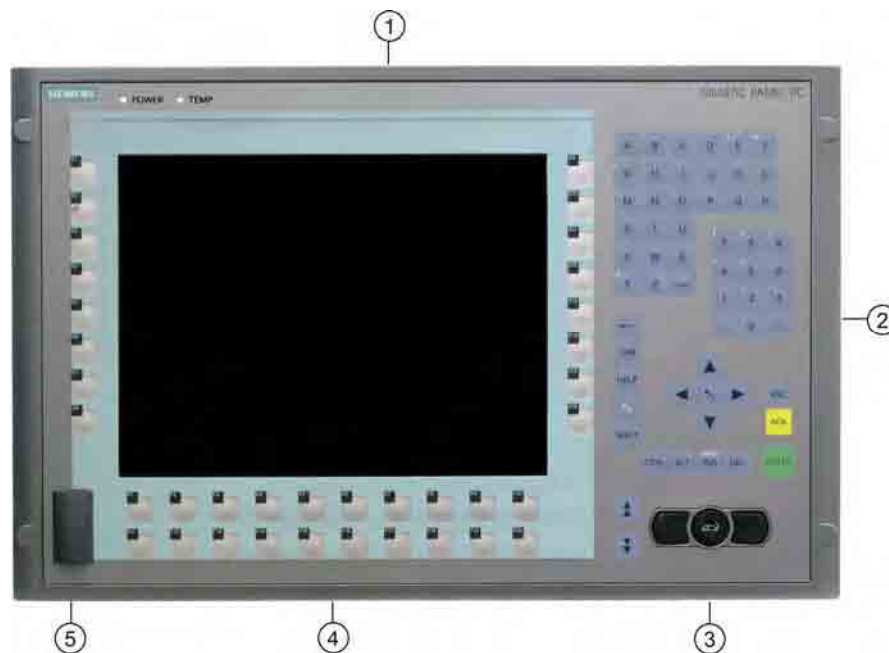

Figure 10-1 Key panel device with 12" display

- (1) Display
- (2) Alphanumeric keys, numeric keys, cursor keys and control keys
- (3) Integrated mouse
- (4) Function keys, softkeys (to the left and right of the display)
- (5) USB interface (in some device variants, the front USB interface cannot be used)

10.3.1 Using the keyboard

The membrane keyboard is divided into different functional groups:

- Function keys and softkeys with LEDs
- Control keys
- Alphanumeric keys
- Numeric keys
- Cursor keys

Function keys

The function keys are arranged in a double row below the display.

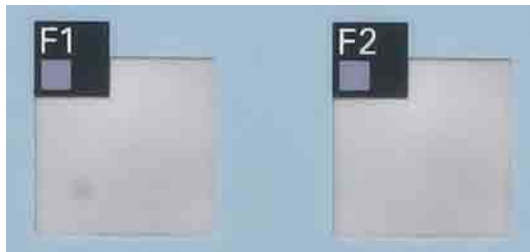

Figure 10-2 Function keys with LEDs, taking the 15" control unit as an example

Softkeys

The softkeys are arranged on the left and the right of the display.



Figure 10-3 Softkeys with LEDs, taking the 15" control unit as an example

Control keys

The control keys activate editing functions and control functions in different applications:

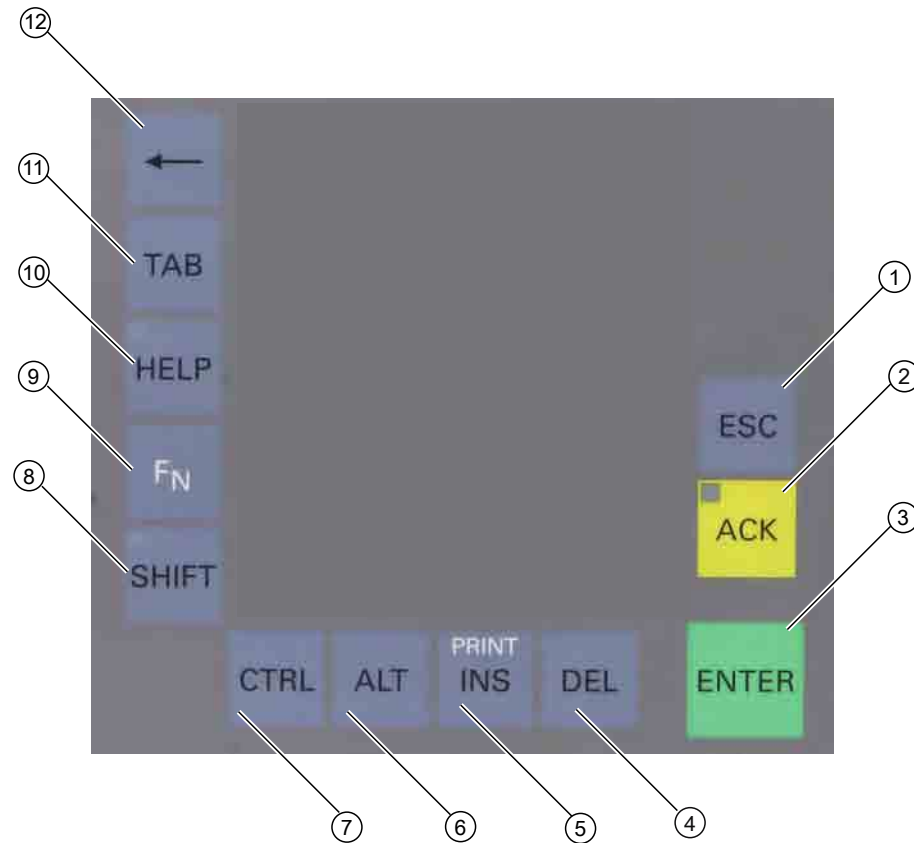

Figure 10-4 Control keys, taking the 15" control unit as an example

- (1) Cancel
- (2) Acknowledge
- (3) Enter
- (4) Delete
- (5) Insert/Print screen (in combination with FN)
- (6) Application-specific functions and special key codes, compare keyboard table in the appendix
- (7) Application-specific functions and special key codes, compare keyboard table in the appendix
- (8) Toggling between lower-case letters and upper-case letters
- (9) Function key
- (10) Call Help
- (11) Tabulator
- (12) Backspace

Alphanumeric keys

Enter letters, special characters, blank spaces and underline using the alphanumeric keys.

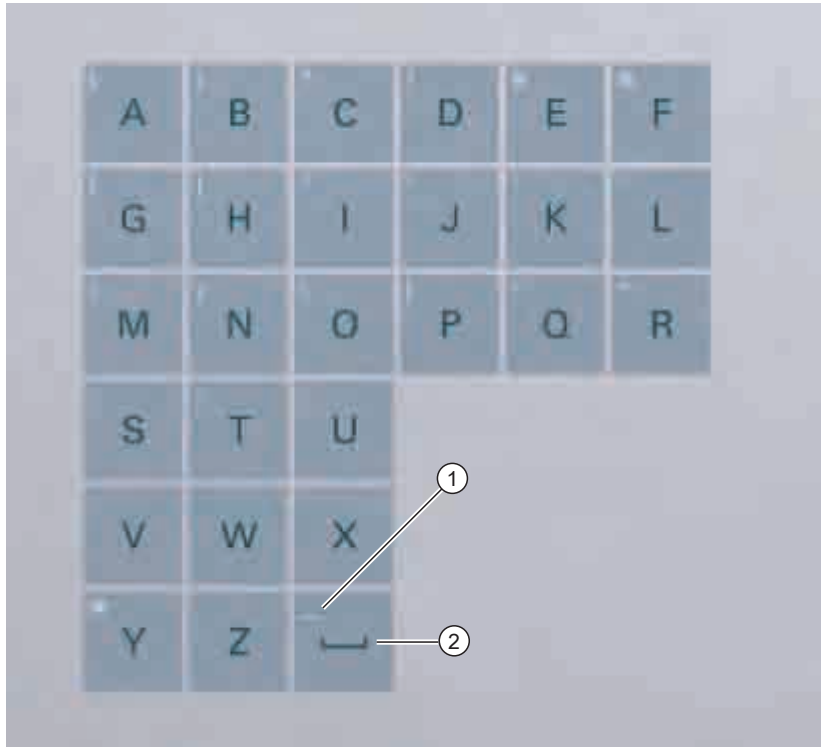

Figure 10-5 Alphanumeric keys

- (1) Underline
- (2) space character

Toggleing between lower-case and upper-case letters

Enter the lower-case letters using the pre-defined assignment of the alphanumeric keys. To enter an upper-case letter, proceed as follows:

1. Hold down the <Shift> key.
2. Activate the desired alphanumeric key at the same time. The displayed upper case letter will be entered.
3. To enter lower case letters, release the <Shift> key.
4. You can, however, also activate the Caps Lock function using the F_N and Shift keys. The LED on the Shift key is then also lit.

Numeric keys

Enter the numerals "0" to "9" and special characters, e.g. the decimal point, using the pre-defined assignment of the numeric keys.



Figure 10-6 Numeric keys

Enter special characters, arithmetic signs and signs

Special characters, arithmetic signs and signs are also assigned to most of the alphanumeric and numeric keys. These signs are indicated by white symbols on the top left of the keys. To enter such a sign, proceed as follows:

1. Hold down the <FN> key.
2. Activate the desired alphanumeric or numeric key at the same time. The displayed special character, arithmetic sign or signs will be entered.
3. To enter the signs of the pre-defined assignment again, release the <FN> key.

Cursor keys

Navigate, scroll or move the writing mark using the cursor keys. The cursor keys correspond to the usual keys of the PC keyboard.

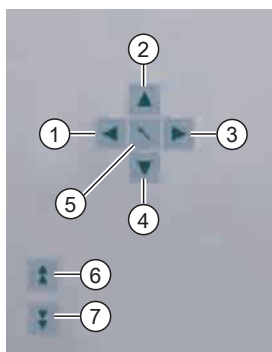

Figure 10-7 Cursor keys

- (1) <Left> key
- (2) <Up> key
- (3) <Right> key
- (4) <Down> key
- (5) Position 1 key (Home)
- (6) <Page up> key
- (7) <Page down> key

External keyboards

The keyboard layout has been set to "English/USA international." If you use a keyboard with a layout other than the "English/USA international" layout, the key codes of the internal and external keyboards might no longer correspond.

Notice

Maloperation

If you activate several keys simultaneously, a malfunction on the device cannot be excluded. Activate function keys and softkeys only in sequence!

Notice

Malfunctions of the user software

For security reasons, always use "Security features" of the KeyTools. If you deactivate it nevertheless, serious malfunctions of the user software may occur when the additional function keys and softkeys F13 to S16 are used or if own key code tables are used.

Notice

Risk of damage

Activating a key using a hard or pointed object, e.g. a screwdriver, reduces the life of the key or can damage it.

10.3.2 Using the direct control key module

The direct control key module is a module that is intended for use with the SIMATIC Panel PC 877 (exclusively for variants with an integral membrane keyboard). Digital events can be assigned to the function keys and softkeys (F1-F20 and S1-S16) of the membrane keyboard via this module. This means that a digital input of a PLC can be activated at the press of a key over PROFIBUS. The module is implemented as a PROFIBUS DP slave.

Functionality

The direct control key module is used to expand the functional scope of the SIMATIC Panel PC 877 with the following features:

- Up to 32 function keys/softkeys on the membrane keyboard of the Panel PC can be scanned over PROFIBUS as direct keys.
- Up to 16 additional keys from an external operator panel can be connected if required.
- There are 16 digital outputs for activating checkback signal lamps (by the PLC over PROFIBUS DP) in external operator panels.

All direct control keys can be scanned over PROFIBUS DP from the PLC.

Software control

At the Panel PC end, the direct control keys are programmed using the "Key pad" software tool. The codes for all keys of the Panel PC 877 can be changed using this tool. It can also be used to assign the direct control key functionality to all function keys and softkeys of the Panel PC. The Key Pad software will be included with the direct control key module on diskette as well as on the Documentation and Drivers CD of all Panel PC 877s .

Mounting

The direct control key module can be ordered separately from the Panel PC. It can be retrofitted in the immediate vicinity of the Panel PC: Either on a standard mounting rail (the mounting equipment required is included in the package with the direct control key module) or directly using 4 screws on a wall / front panel / control panel. Detailed mounting instructions are included with every direct control key module on paper and with every Panel PC 877.

Example:

The keyboard codes, that are sent when any key is operated, are stored in a code table. The initial status of the table is as follows:

Table 10-1 Keyboard codes

Keys:	Keyboard code:
All standard PC keys	"English international"
Additional keys for Panel PC 877	
F13 - F20	SHIFT+F1 - SHIFT+F8
S1 - S4	SHIFT+F9 - SHIFT+F12
S5 - S16	CTRL+F1 - CTRL+F12

This default setting for additional function keys corresponds to the specifications required for using the keys (for example, from the HMI software package SIMATIC WinCC flexible).

Changing the defaults

The program "KeyPad.exe" can be used to assign each key individually with special key codes.

The following example shows the layout of the 15" Panel PC keyboard variant after starting the relevant program for the device "keypads15.exe":

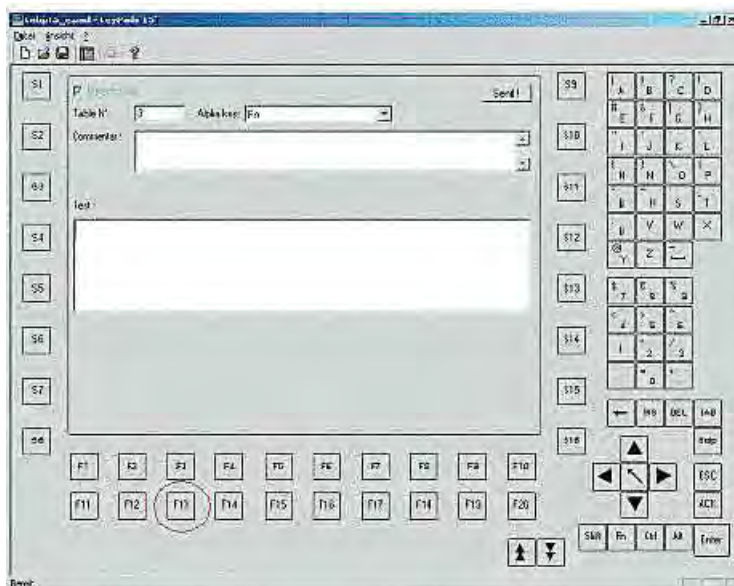

Figure 10-8 KeyPad

The individual key fields can be clicked to open a configuration form for the respective key. In the example, the form for standard assignment of the F13 key is shown:

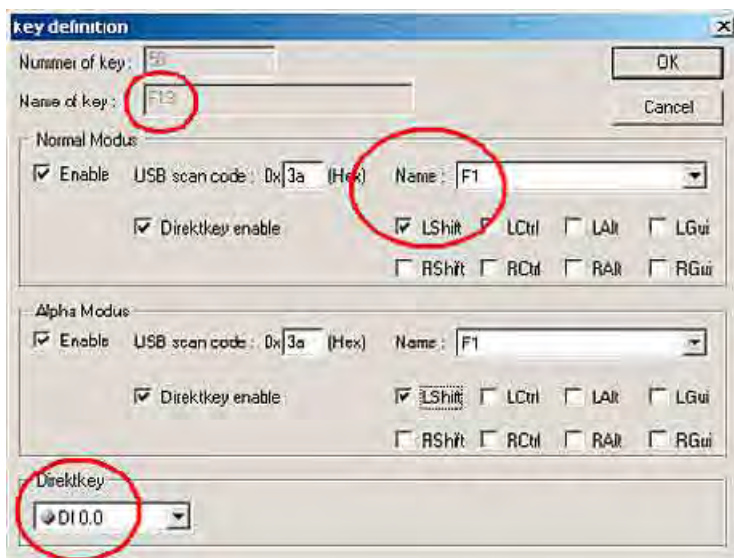

Figure 10-9 Standard assignment of the F13 key

Explanation:

The key labelled **F13** outputs the key code **LSHIFT+F1** and sets digital input DI 0.0 when the direct key module is used.

For further information about using the tool, visit the Internet page <http://www.siemens.com/asis>. Search here under "Download" using the term "Keypad".

The self-unpacking file F_KEY_Total.exe contains extensive information (description in English and German, examples) on using the additional function keys of the Panel PC 877.

10.3.3 Labelling function keys and softkeys

Area of application

This section applies only to control units with key panels.

Introduction

The control unit has two horizontal and two vertical keypads. Assign user specific functions to the keys as needed. Label the keys with labelling strips from the options.

DIN A4 film is available for the production and insertion of the labeling strips, as described in chapter 3 "Description".



Warning

Labeling

Label the function keys and softkeys to conform with the project. Labeling without reference to a project leads to incorrect operations on the system to be observed.

Procedure

1. Label the DIN A4 film with a laser printer, for example, using the print format templates for MS Word on the Documentation and Drivers CD.
2. Cut the labeling strips along the pre-printed lines.

Note

Do not insert handwritten labeling strips until the ink has dried.

3. Insert the labeling strips into the slots provided on the rear side of the control unit.

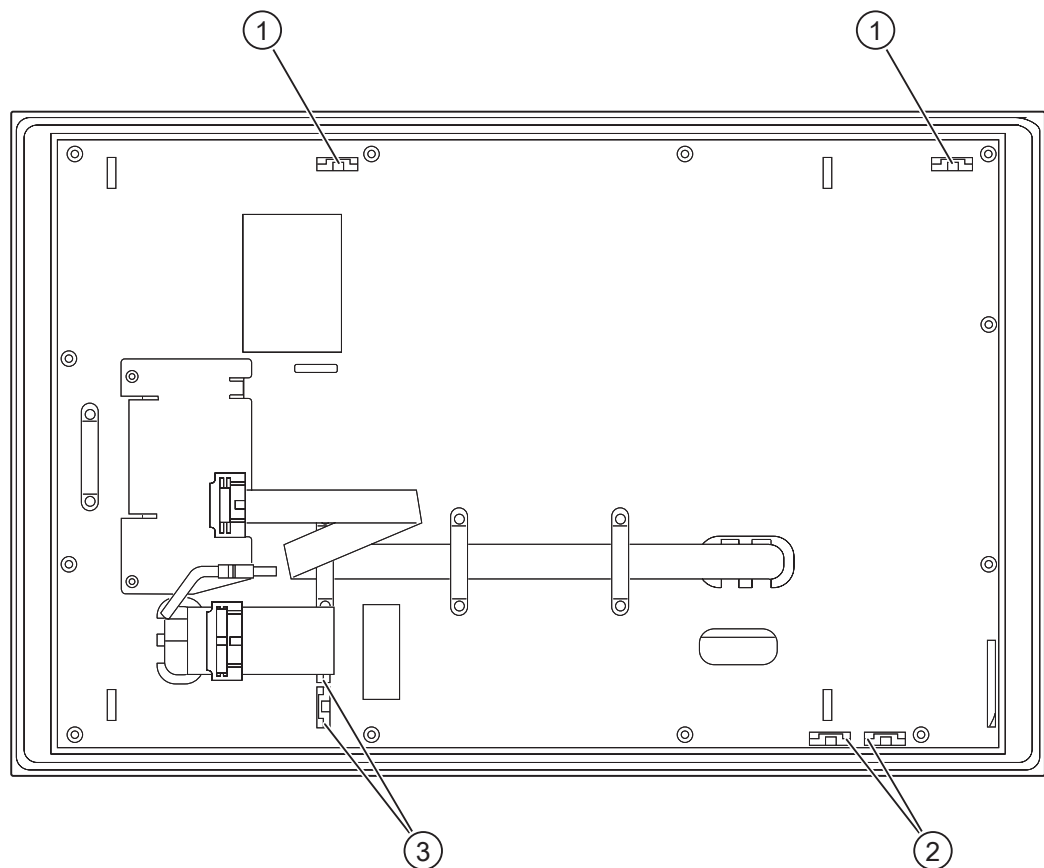

Figure 10-10 Rear side of the control unit with connections and slots for the labeling strips for the example of a 12" touch panel front.

- 1 Slots for long labeling strips, vertical keypads
- 2 Slots for short labeling strips, horizontal keypads
- 3 Slots for labeling strips, horizontal keypads

10.3.4 Using the integrated mouse

The position on which you press the middle round button of the integrated mouse determines the direction in which the cursor moves. The amount of pressure determines the speed of the cursor.

Alternatively to using the integrated mouse you can also connect an external mouse to the front USB port.



Figure 10-11 Integrated mouse

10.4 Device with touch screen

The 15" variant and the 19" variant differ in their dimensions and the size of the display. The 19" variant has no drill hole covers on the sides.

The following figure is only an example using the front view of the 15" variant.

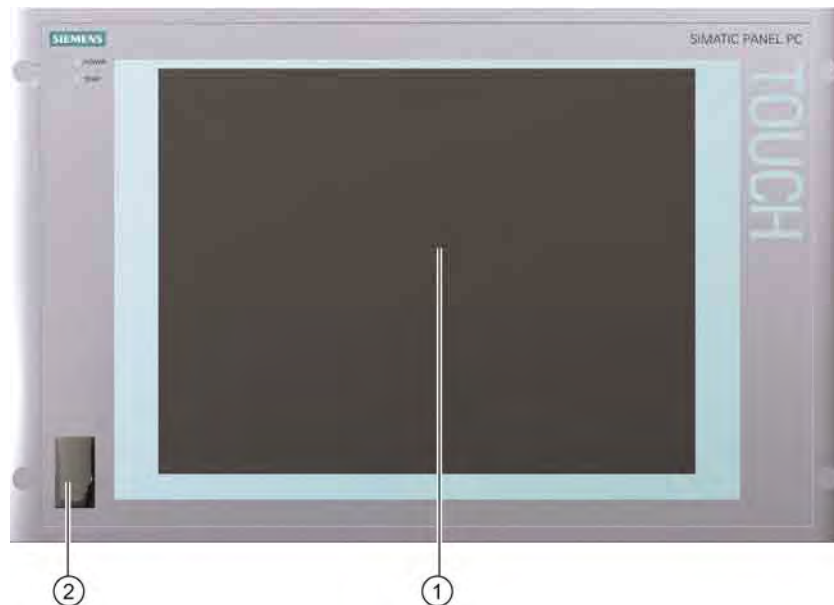

Figure 10-12 Example of a 15" touch screen front

- (1) Display with touch screen
- (2) USB interface (in some device variants, the front USB interface is not accessible)

10.4.1 Using the touch screen

On the display that is touch-sensitive due to the touch sensor, application-specific user interface elements, for example buttons, are displayed. When you tap the command button with your finger, the function assigned to the button is activated.

The following types of pressure are permissible:

- Using a plastic pen with a 1 mm radius at the point: 25 g.
- Using a silicone finger with a diameter of 1.6 cm: 50 g.

Caution

Only touch one point on the touch screen and not several points at one time. You may otherwise trigger unintended reactions.

Do not touch the screen in the following situations:

- During the booting process
 - When plugging or unplugging USB components
 - While Scandisk is running
-

Notice

Touching the touch screen with hard or pointed objects can damage the screen and thus impair its functionality. Only operate the touch screen with your fingers (even with gloves) or approved touch pens.

10.5 Disk drive

Introduction

The device is equipped with a 3.5" floppy drive as standard. You can use the floppy drive to save programs and data and transfer data from the floppy disk to the device.

Diskette types

The follows diskettes are supported:

Double sided double density	Double sided high density
720 KB	1.44 MB, 135 TPI

Caution

Data loss!

Do not press the ejection button when the green access LED of the drive is lit.

10.6 Transferring authorizations

Authorizations of HMI software are provided on diskette. Transfer these, if required, from the built-in diskette drive.

Functions

11.1 Overview

The following individual functions are implemented:

- Temperature monitoring and over/under temperature indication
- Watchdog
- Fan monitoring

Messages can be output from the monitoring modules to the applications.

The SOM software (Safecard On Motherboard) and DiagMonitor software are provided on the devices for this.

The "DiagMonitor Software" CD contains the monitoring software, the software for the stations to be monitored, and a library for creating user-specific applications. The DiagMonitor software can be ordered as an accessory with a separate order number.

The description of the driver and the SOM program are available on the "Documentation and Drivers" CD.

11.2 Safecard on Motherboard (SOM)

The "Safecard On Motherboard" software is available on the "Documentation and Drivers" CD. Before this software is installed, previously installed DiagMonitor software must be deinstalled.

This application is used to monitor PC hardware (temperature, watchdog and fans) and to display the current measured values. A GUI is used to configure the application and also to activate the temperature monitoring watchdog function and fan monitoring function.

Your device is equipped with three temperature sensors, which are automatically detected by the application.

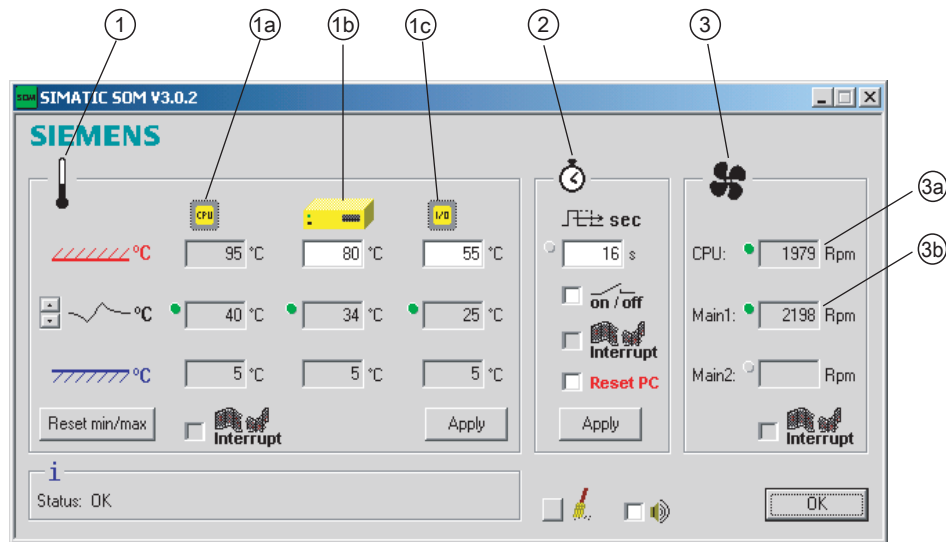

Figure 11-1 Safecard On Motherboard with three temperature sensors

(1)	Temperature range	Here the current temperature and limit values are shown. You can toggle the temperature display mode to indicate either the current temperature, or the min./max. values measured since the start of the application.	
		(1a)	Internal processor temperature
		(1b)	Device temperature beneath the power supply: upper threshold can be set from 30°C to 80°C
		(1c)	Cooling air temperature surrounding the DVI connector: - depending on device 3°C to 5°C higher than the ambient temperature - upper threshold can be set from 25°C to 55°C
(2)	Watchdog range	Here, you can configure the watchdog function in your monitoring application. You can specify the watchdog time, activate a PC reset and activate / deactivate the watchdog.	
(3)	Fan area	You can read the current fan speed in this area.	
		(3a)	Fan speed in the area close to the processor
		(3b)	Fan speed on the power supply

The description of the drivers and SOM software for Windows is available on the "Documentation and Drivers" CD under **Drivers/Tools >Tools>PPC877**.

From the CD, run **Install.bat** and follow the instructions on your screen.

11.3 Temperature monitoring

Temperature monitoring

The temperature is recorded by means of three thermocouples. One thermocouple monitors the processor temperature, another the temperature in the area near the processor module, and a third the temperature in the area of the disk drives.

When the temperature is out of the range of one of the three set temperature thresholds, the following error reactions are triggered:

Response	Option
Device and CPU fans accelerate to maximum speed.	None
SOM or DiagMonitor software is activated	None

The temperature error is retained until the temperatures have fallen below the thresholds and are reset by one of the following measures:

- Error acknowledgement in the SOM program (manually by means of the broom icon)
- Restart of the device

Notice

When an error occurs, the "TEMP" LED also illuminates with the status indicators.

11.4 Watchdog (WD)

Function

The watchdog monitors the program execution and reports a program crash to the user by means of various reactions.

The watchdog is idle when the PC is switched on or after a HW-RESET(cold restart), i.e., no reaction of the WD is triggered.

WD reactions

If the WD is not triggered again within the set time (by driver or SOM program), the following reactions are initiated:

Response	Option
WD acknowledgement	None
Trigger a PC reset	Configurable
SOM or DiagMonitor software is activated	None

WD monitor times (TWD)

The TWD are adjustable in increments of one second in a range from 3 to 255 seconds.

Note

If the watchdog time is changed after the watchdog was enabled (i.e., while the watchdog is running), the watchdog is retriggered!

11.5 Fan monitoring

This function monitors operation of the housing and processor fans. When a fan fails, the following reactions are triggered:

Response	Option
SOM or DiagMonitor software is activated	None

The temperature error is retained until the cause of the fan failure has been rectified and the error is reset in one of the following ways:

- Acknowledgement of the error message by means of the SOM program
- Restart of the device

Maintenance and service

12.1 Servicing

Scope of maintenance

When working in areas where there is dust that may be hazardous to functionality, the device must be operated in a control cabinet with a heat exchanger or with suitable supply air.

Note

Dust deposits must be removed at regular intervals.

Maximum dust content in the air circulating in the cabinet	
Suspended component	0.2 mg/m ³
Deposits	1.5 mg/m ³ /h

Cleaning agents

Use dish soap or foaming screen cleaner only as cleaning agents.

Caution

Do not clean the device with aggressive solvents or scrubbing agents or with pressurized air or steam cleaner.

Chemical stability

Caution

Adhere to the information regarding chemical resistance of the panel front. Please go to <http://www.siemens.com/asis> under "Tools & Downloads" for more information. Enter the article ID 16532108 as the search term. The available articles are displayed.

Procedure for cleaning the device

1. Switch off the device. This prevents the accidental triggering of functions when the screen is touched.
2. Dampen the cleaning cloth.
3. Spray the cleaning agent on the cloth and not directly on the device.
4. Clean the device with the cleaning cloth.

12.2 Replacement parts

The device has the following replacement parts:

Replacement part	Order No.
Key panel	
12"-TFT	6AV7672-1AB00-0AA0
15"-TFT	6AV7672-1AD00-0AA0
Touch panel	
15"-TFT	6AV7672-1AC00-0AA0
19"-TFT	6AV7672-1AE00-0AA0
Key front, without front USB interface*)	
12" TFT	6AV7672-1AB10-0AA0
15" TFT	6AV7672-1AD10-0AA0
Touch front, without front USB interface*)	
15" TFT	6AV7672-1AC10-0AA0
19" TFT	6AV7672-1AE10-0AA0
Set of clamps	6FC5248-0AF06-0AA0
Plastic cap USB interface	A5E00378392
Lithium battery	A5E00331143

*) For more information, please refer to the chapter "Description."

Use only Siemens spare parts or spare parts released by Siemens, otherwise the warranty, CE declaration of conformity and UL approval will be invalidated.

12.3 Separating the control unit from the computer unit

Introduction

The control unit is separated from the computer unit to carry out repairs or to replace the control unit, for example.

Procedure

1. Disconnect the device from mains.
2. Open the switchgear cabinet. The device is now accessible from the back.
3. To swing away the computer unit (1): Loosen the four knurled screws (2) which attach the computer unit to the rear of the control unit (3).



Figure 12-1 Separating the control unit from the computer unit

4. Swing the computer unit (1) away. The connectors on the back of the control unit (3) are now accessible.

5. Loosen cables K1 to Kx and the USB cable between the computer unit and the control unit
6. Two mounting rails are screwed onto the computer unit whose angled ends (4) are located in the corresponding recesses in the computer unit. Lift the computer unit vertically out of these recesses
7. Put the computer unit down carefully.
8. Where necessary, also remove the control unit depending on its design: Secure the control unit against falling out and unscrew it. Or remove the clamps which secure the control unit to the installation wall, as shown in the mounting cut-out in the dimensions diagram.

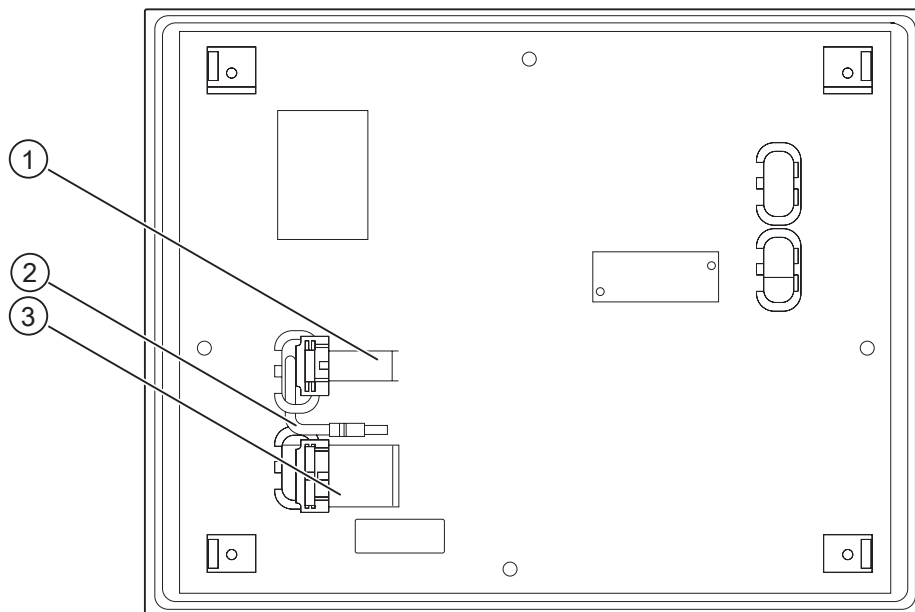

Figure 12-2 Other interfaces on the computer unit

- 1 Display cable K2 and display cable K3 *)
- 2 USB cable
- 3 IO/USB cable K1

*) Only for 19" touch panel fronts.

12.3 Separating the control unit from the computer unit

Separating the device in an uninstalled state

As an alternative, dismount the device completely and separate the control unit and computer unit from one another in an uninstalled state. So that the processing unit, which is swung away from the control unit, does not bend the lugs (4), place a surface under the processing unit.

Mounting operator control unit on computer unit

To mount the operator control unit on the computer unit, perform the steps in reverse:

Caution

When you swing the control unit and processing unit together, make sure that the flatband cables are correctly folded together and do not get squished.

In order to do this, fold the flatband cables gently with specific spacing, as shown. The bend dimensions are specified in the following table. The USB cable does not have to be folded because it is stored as a loop in the processing unit.



Figure 12-3 Separate the control unit from the computer unit, example regarding folding cables

Position	Bend dimension
A	4.5 cm
B	4 cm

12.4 Installing and removing hardware components

12.4.1 Repairs

Notice

Similar to figure

The images presented below deviate slightly from the actual device in some respects.

Carrying out repairs

Only authorized personnel are permitted to repair the device.



Warning

Unauthorized opening and improper repairs on the device may result in substantial damage to equipment or endanger the user.

- Before you open the device, always disconnect the power plug.
- Install only system upgrades designated for this computer and released by SIEMENS. All technical data and licenses apply only to upgrades approved by SIEMENS. Installation of unsuitable components violates the regulations for UL approval and EMC. Impermissible expansions can damage the system. Contact your technical support team or your sales outlet to find out which system upgrades are suitable for installation.

If you install or exchange system expansions that damage your device, or if you use unsuitable components, the warranty becomes void.

Notice

Note the ESD instructions.

Limitation of Liability

No liability can be accepted for impairment of functions caused by the use of third-party devices or components.

Tools

You can perform all installation tasks on the device using Torx T6, Torx T10, and Torx T20 screwdrivers and a Philips screwdriver.

12.4.2 Open the device

Caution

Work on the open device may only be carried out by authorized and qualified personnel. Within the warranty time, you are only allowed to install expansions for memory and expansion card modules.



Caution

The device contains electronic components which may be destroyed by electrostatic charge.

You therefore need to take precautionary measures before you open the device. Refer to the (ESD) directives for handling components which are sensitive to electrostatic charge.



Tools

You can perform all installation tasks on the device using Torx T6, Torx T10, and Torx T20 screwdrivers and a Philips screwdriver.

Preparation

Disconnect the device from mains.

Open the device

Steps for opening the device		
1	Remove the five screws (1).	
2	Swing the lid to the front and remove it.	

12.4.3 Installing and removing memory modules

Memory expansion

The motherboard is equipped with 2 slots for memory modules. 184 pin DDR266 or PC2700 memory modules can be used, unbuffered, no ECC. This enables you to expand the memory capacity of the device to a maximum of 2 GB. These slots can be fitted with one or two memory modules.

Combination	Slot X3	Slot X4	Maximum expansion
1	256/512 MB/1 GB		1 GB
2	256/512 MB/1 GB	256/512 MB/1 GB	2 GB

Note

Any module can be plugged into any slot.



Preparation

Disconnect the device from mains and unplug all cables.

Caution

The electronic components on the PCBS are highly sensitive to electrostatic discharge. It is therefore vital to take precautionary measures when handling these components. Refer to the directives for handling electrostatic sensitive components. For more information, please refer to the section "ESD directives".

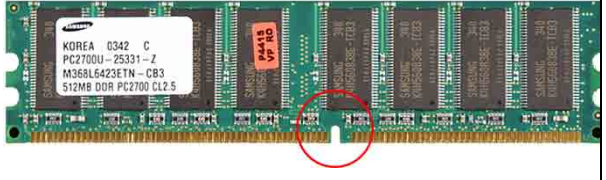
Installing a memory module

How to install a memory module		
1	Open the device.	
2	Note the recess and polarity reversal protection on the connector side of the memory module.	
3	Push the module carefully into the slot until the interlocks engage	
4	Close the device	

Removing a memory module

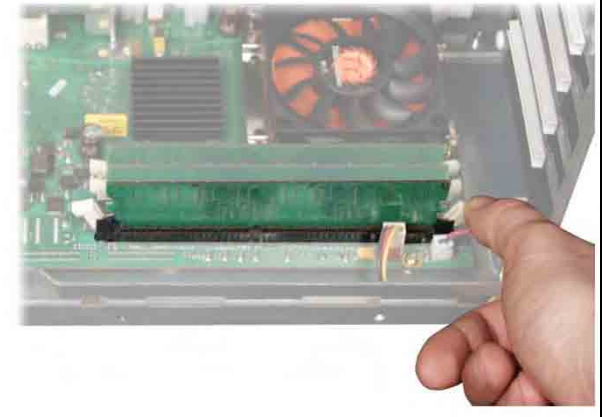
How to remove a memory module		
1	Open the device.	
2	Open the left and right interlocks	
3	Pull the memory module out of the slot	
4	Close the device	

Displaying the memory configuration

A new memory module is automatically detected. The allocation of the "base memory and extended memory" is displayed when you switch on the device.

12.4.4 Installing PCI / AT cards

12.4.4.1 Notes on the modules

Notes on module specifications

The device is designed for use with modules conforming to AT/PCI specifications. PCI modules with 5 V and 3.3 V supply voltage can be operated. The permitted dimensions of the modules are found in the dimensional drawings section.

Note about long PCI modules

Before long PCI modules can be inserted into the guide rails, they must be fitted with an extender (this should be supplied with the long PCI board).

12.4.4.2 Installing / removing expansion modules

Preparation

Disconnect the device from mains.

Installing expansion modules

How to install an expansion module (PCI / AT format):		
1	Open the device.	
2	Loosen the two fastening screws (1) and remove the module holding-down device (2).	
3	Remove the relevant steel slot cover (3).	
4	Insert the expansion module (4) into the relevant slot.	
5	Install the module holding-down device and insert the slider.	
6	Secure the steel slot cover (3) of the expansion module.	
7	Close the device.	

Inserting the slider

To insert the slider:

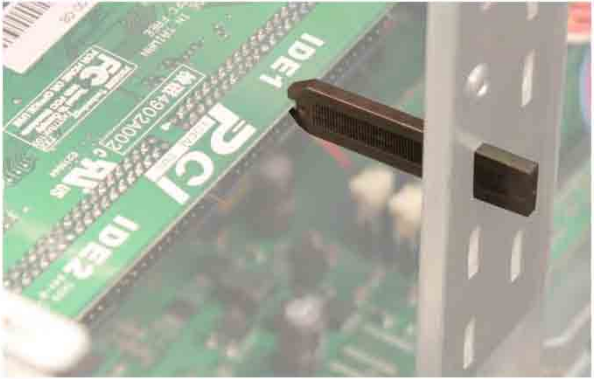
How to install a module holding-down device	
1	<p>Push the slider through the guide slot until it is seated firmly on the module. Insert the module into the slot.</p> 

Caution

Do not apply any pressure to the module. Therefore, do not apply excessive force to the slider when you push it onto the module.

2	<p>Cut off the rest of the slider: Use a knife to notch the slider at the upper edge of the bracket and then break this section off. Cut off the residual element using a sharp side cutter.</p> 
---	---

12.4.4.3 Exchanging the RAID controller PCI card

Introduction

The RAID system uses the following controllers:

- System with SATA drives: Promise Fast Track TX2300

Principle

The RAID controller PCI card is installed in PCI slot 5 of the bus module.

12.4.5 Disk drives

12.4.5.1 Options of installing disk drives

Drive bay module for hard disk drives, optical drives and floppy disk drives

DVD-ROM/CD-RW drive bay	Pos	Description
	(1)	DVD-ROM/CD-RW drive bay
	(2)	Mounting slot for DVD-ROM or DVD-ROM/CD-RW drive

Hard disk drive bay for one 3.5" drive	Pos	Description
	(1)	Hard disk drive bay for one 3.5" drive
	(2)	Mounting slot for a 3.5" hard disk drive bay

Drive bays for two 2.5" hard disks	Pos	Description
	(1)	Hard disk drive bay for 2.5" hard disks
	(2)	Two mounting slots for 2.5" hard disks



Drive bay for floppy disk drive	Pos	Description
	(1)	Floppy disk drive

12.4.5.2 Installing / removing a drive bay



Preparations



Disconnect the device from mains and unplug all cables.

Remove the hard disk bay

Steps for removing the drive bay		
1	Remove the four screws (1)	
2	Remove the hard disk bay and place it onto the device	

Removing drive bays for floppy disk drives

Steps for removing the floppy disk drive bay		
1	Remove the four screws (1)	
2	Remove the hard drive bay and place it onto the device.	

Steps for removing the floppy disk drive bay	
<p>3 Remove the data cable between the floppy disk drive (1) and the motherboard and its power supply connector (2). Remove the screw (3) and open the bracket. Disconnect the connecting cable for the optical drive.</p>	 <p>The image shows the internal components of a drive bay. A hand is shown disconnecting a ribbon cable from the floppy disk drive (1). A power supply connector (2) is also visible. A screw (3) is being removed from the drive bay bracket.</p>
<p>4 Remove the three screws (1)</p>	 <p>The image shows the external view of the drive bay. Three screws (1) are circled in red, indicating they need to be removed.</p>
<p>5 Lift the drive bay out</p>	

12.4.5.3 Removing and installing an optical drive

Procedure

1. Unscrew the 4 screws (1) holding the drive and slide the drive out.



Figure 12-4 Installing and removing the optical drive

1. If you need to completely remove the drive, remove drive connectors (1) and (2) from the device.



Figure 12-5 Drive connectors

2. Loosen the 2 screws (1) of the drive housing.



Figure 12-6 Drive with housing

3. Flip up the housing cover (1) 90°.



Figure 12-7 Drive removed, housing flipped up

4. Remove the connector of the ribbon cable from the socket (2).
5. Loosen the 3 screws (3) with a TX6 key.
6. Remove the drive (4) from the bracket.
7. Loosen the 2 screws (5) on the board (6).

Notice

Loose spacer bolts are located between the housing and the board. When loosening the board, hold the spacer bolts in place.

8. Remove the board (6).

Reverse the procedure to install the drive.

12.4.5.4 Removing and installing a 3.5" hard disk

Procedure

1. Unscrew the 4 screws from the drive housing and slide the drive out. The drive is secured to the underside of the drive housing.
2. Note the cable arrangement and then remove the cables from the motherboard.



Figure 12-8 Removed hard disk

3. Loosen the 4 screws that secure the hard disk to the drive bay.
 4. Remove the drive from the bracket.
- Reverse the procedure to install the drive.

12.4.6 Replacing the backup battery

Note

Batteries are wearing parts and should be replaced every five years in order to ensure proper functioning of the PC.

To be noted before you replace the battery

Caution

Risk of damage!

The lithium battery may only be replaced with an identical battery or with a type recommended by the manufacturer (Order No.: A5E00331143).



Warning

Risk of explosion and release of harmful substances!

Therefore, do not throw Lithium batteries into an open fire, do not solder or open the cell body, do not short-circuit or reverse polarity, do not heat up above 100° C, dispose as regulated and protected against direct exposure to sunlight, humidity and dewing.

Disposal

Caution

Batteries must be disposed of in accordance with local regulations.

Preparation

Note

The configuration data of the device are deleted when the battery is replaced.

5. Note down the current settings of the BIOS Setup.
A list in which you can note down this information is found in the BIOS manual.
6. Disconnect the device from mains and unplug all cables.

Replacing the battery

Follow the steps outlined below:

Steps for replacing the battery	
1	Open the device.
2	Disconnect the plug (1) and take the battery (2) out of the retainer.
3	Place a new battery in the holder and reconnect the battery plug.
4	Close the device.

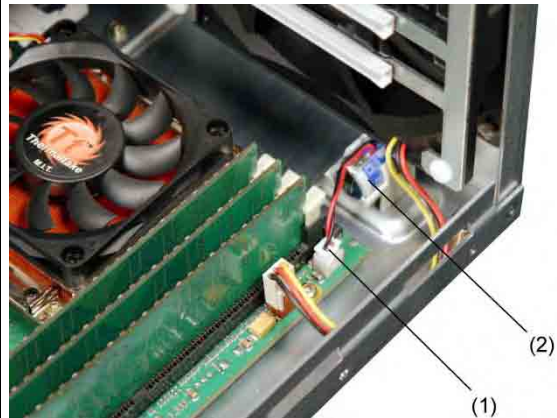

Reconfiguring the BIOS Setup

When a battery is exchanged, the configuration data of the device are lost and must be reentered in the BIOS setup.

12.4.7 Removing/Installing the Power Supply



Warning



Only qualified personnel is authorized to exchange the power supply module.

Preparations

1. Disconnect the device from mains and unplug all cables.
2. Open the device.

Removing the power supply module

How to remove the power supply module		
1	Remove the hard disk drive bay.	
2	Remove the 6 screws (1) and the cover of the power supply module.	<p>(1)</p>
3	Disconnect the power supply cables of all drives.	
4	Remove the 3 fastening screws (1) (Torx T10).	<p>(1)</p>

How to remove the power supply module		
5	Disconnect the power supply connector from the motherboard.	
6	Pull the power supply module out to the front.	
7	Also remove the four screws holding the steel bracket of the PS and take it off. These are special screws with imperial dimensions (6-32x3/16"-St-G3E).	

12.5 Installing Software

12.5.1 General installation procedure

If the system is unstable or if the operating system reports errors, the delivery status of the device can be easily restored using the Restore DVD. You can re-install the operating system and relevant drivers using the Recovery CD and the "Documentation and Drivers" CD.

Recovery CD:

The new recovery procedure is based on Windows PE (Preinstalled Environment). The CD contains a Windows PE user interface with tools for configuring the hard drives and the operating system.

Documentation and Drivers CD:

Contains the documentation and the hardware drivers.

Restore DVD:

Contains a hard disk image file with the original software (operating system with installed hardware drivers).

12.5.2 Setting up the partitions for Windows operating systems

After you have installed a new hard disk, or if partitions are faulty, or when you wish to change the partitioning on your hard disk, you need to create or reconfigure partitions on the hard disk

Caution

When you delete or create partitions or logical DOS partitions, you lose all data on the hard disk. All partitions on the hard disk will be deleted.

With the Windows 2000 Professional and Windows XP Professional operating systems, the factory state features two partitions with an NTFS file system on the hard disk. To restore the partitions to factory state, proceed as follows:

Setting up partitions

1. Boot from the Recovery CD and then follow the screen instructions until the Recovery functions window is displayed.
2. Start the DiskPart program in the "Siemens SIMATIC Recovery" window and enter the following commands in the displayed command interface:

list disk	Displays all available hard disks.
select disk 0	Selects the disk where you wish to change the configuration. 0 selects the first hard disk.
list partition	Displays all partitions on the selected hard disk ¹⁾
clean	Completely wipes the selected hard disk. All information stored there is lost.
create partition primary size=n	Creates a primary partition with the n MB on the selected hard disk. Factory state values: n = 10000 for Windows 2000 Professional or XP Professional
select partition 1	Select the primary partition
active	Activates the selected partition ¹⁾
exit	Closes DiskPart.
1) The active partition is identified with a *.	

Additional DiskPart functions:

Help	Shows all available DiskPart commands. When a command is supplemented with other parameters, the command is described with additional information. Example: create partition help
------	--

Note

Once you have changed the configuration of your hard disk with DiskPart, you will need to reboot the PC for the changes to go into effect.

Boot again from the Recovery CD to format the partitions.

Format primary partition

1. Boot from the Recovery CD to format the partitions. Follow the screen instructions until the Recovery functions window is displayed.
2. Select "Start command prompt" in the Recovery functions window. In the command interface that opens, enter the following command:
`format DL:/FS:File System`
DL = Drive letter of the partition to be formatted. Valid values: C, D, E, F etc.
File system = Specifies the type of file system. Valid values: FAT, FAT32, NTFS.

NTFS is the factory setting for all Windows operating systems.

Example for a master hard disk on the IDE bus:

```
format C:/FS:NTFS
```

Note

Parameter overview

`format /?` shows all parameters of the command.

12.5.3 Compatibility of the Restore DVD

Caution

Use only the supplied Restore DVDs for the device. Verify that the order number of the Restore DVD matches that of the device. You can find the order number of the device on the rating plate.

Do not use the supplied images for any other device. The chipsets and drivers differ.

12.5.4 Restoring the factory state of the software using the Restore DVD

You can restore the software to the original factory state using the Restore CD (not included in all package variants). The DVD contains the necessary images and tools for transferring the factory software to the hard disk of your PC. You can restore the entire hard disk with drive C: (system) and drive D: or only drive C: at the command line input. This allows you to retain any user data on drive D.

Recovering authorizations or license keys for SIMATIC software from the hard disk

- If you have installed SIMATIC software with a license key or authorization on the PC, please check if you can recover the license key or authorization on the hard disk. The transfer of license keys or authorizations is described in the Help of the Automation License Manager program.
- If it is not possible to back up your authorization, please contact the Customer Support Hotline. There you can obtain information necessary for your software authorization.

Caution

With the option "Restore system partition only", all data on drive C: (System) will be deleted. All data, user settings and all authorizations or license keys on drive C: will be lost in the process! All data on drive C: of your hard disk will be deleted. Setup formats the hard disk partition and reinstalls the original factory software.

When you select the "Restore entire hard disk" option, ALL the data, user settings and authorizations or license keys will be lost on the hard disk.

Restoring the factory state with the installed drive

To restore the factory state, proceed as follows:

1. Make the following setting in the BIOS Setup:
Menu Exit > Get Default Values
2. Insert the Restore DVD in the drive and reboot the device. When the BIOS message "Press <F2> to enter Setup or <ESC> to show Boot Menu" appears, press the ESC key. After initialization, a "Boot Menu" is displayed.
3. Select the optical drive with the cursor keys.
4. Now follow the instructions on the screen.

Caution

All existing **data, programs, user settings** and **authorizations or License Keys** will be **deleted** from the hard disk and are therefore lost.

Restoring the factory state with an external USB CD/DVD ROM

Procedure:

1. Connect the external USB CD/DVD ROM to the Panel PC and reboot the device.
2. Activating the Legacy Support in the BIOS
 - Press the <F2> key when the BIOS message "Press <F2> to enter Setup" appears.
 - Select "Advanced"
 - Activate the "Legacy Support"
USB Boot [enabled]
USB Legacy Keyboard/Mouse [enabled]
 - Save the settings and exit the BIOS with Save Changes & Exit
 - Switch off the Panel PC
3. Restoring the factory state
 - Place the Restore DVD into the drive and restart the device using the on/off switch (min 15s).
 - During the self-test phase, press the < ESC > key. After initialization, a boot menu is displayed.
 - Select the external optical drive with the cursor keys.
 - Now follow the instructions on the screen.

Caution

All existing **data, programs, user settings** and **authorizations or License Keys** will **bedeleted** from the hard disk and are therefore lost.

For information on the functions, refer to the README.TXT file on the Restore DVD.

12.5.5 Installing Microsoft Windows operating systems

12.5.5.1 Operating system not installed

The device can be optionally purchased without an operating system. If you want to install the operating system yourself, read the information available in the Internet at <http://www.siemens.com/asis>

Notice

You must integrate the required software components yourself if you install an operating system not offered by Siemens AG. Note the following in this regard:

- The device has features that a standard PC does not, for example, a touch screen and front panel function keys.
 - Siemens AG can only guarantee the availability of these features for operating systems that have been released.
 - Siemens AG only provides support within a strictly defined framework.
-

12.5.5.2 Booting from the Recovery CD

Please use the Recovery CD to install Windows to meet your special requirements. The operating system used is Windows Preinstall Environment (WinPE). You will also need the supplied Documentation and Drivers CD.

Booting with the Recovery CD:

1. Insert the Recovery CD in the drive and reboot the device. When the BIOS message "Press <F2> to enter Setup or <ESC> to show Boot Menu" appears, press the ESC key. After initialization, a "Boot Menu" is displayed.
2. Select the optical drive with the cursor keys.
3. Please follow the on-screen instructions until the "Siemens SIMATIC Recovery" window appears.

12.5.5.3 Installing the Microsoft Windows operating system (not for RAID)

The recovery CD contains encrypted data that can only be transferred to this system.

Please use the Recovery CD to install Windows to meet your special requirements. The operating system used is Windows Preinstall Environment (WinPE). You will also need the supplied Documentation and Drivers CD.

Booting with the Recovery CD

1. Boot from the Recovery CD and when the BIOS message "Press <F2> to enter Setup or <ESC> to show Boot Menu" appears, press the ESC key. After initialization, a "Boot Menu" is displayed.
2. Select the optical drive with the cursor keys.
3. Please follow the on-screen instructions until the "Siemens SIMATIC Recovery" window appears.
4. After copying the Windows installation files, return to the Siemens SIMATIC Recovery main menu (click "Back").
5. Select "Start command prompt" in the Recovery functions window.
6. Enter the following command in the displayed command prompt interface:
DL:
cd \I386
Winnt32.bat
DL: Drive letter of the folder containing the I386 directory.
7. The preparation of the Windows installation is displayed.
8. When this is completed, close the command prompt with the `exit` command.
9. Close the Siemens SIMATIC Recovery window with the "Finish" button.
10. The Windows installation is completed following an automatic restart of the system.
11. Follow the instructions on the screen.

Note

If you are using Microsoft Windows 2000 Professional or Windows XP Professional, you should have the following manuals at your disposal (not included in the product package): Microsoft Windows 2000 Professional Resource Kit (MS Press No. 24) or Microsoft Windows XP Professional, The Technical Reference" (MS Press No. 934).

These manuals contain special information for administrators involved in installing, managing and integrating Windows in networks or multi-user environments.

12.5.5.4 Installing the Microsoft Windows operating system (for RAID)

RAID Recovery

Notes on RAID systems (Optional)

To install the operating system with the RAID option, the following steps must be carried out:

1. When the device starts up, press <Ctrl> + <F> to enter the BIOS setup of the RAID controller.
2. Select the AUTO SETUP option, to connect a RAID (choice between RAID 0 "Stripe" and RAID 1 "Mirror").
3. After the RAID has been connected, the device must be rebooted.
4. Boot from the Recovery CD and when the BIOS message "Press <F2> to enter Setup or <ESC> to show Boot Menu" appears, press the ESC key. After initialization, a "Boot Menu" is displayed. Select the optical drive with the cursor keys there.
5. During the power-up phase of the "Recovery CD", press F6 to integrate the RAID Controller Fast Track TX 2300.
The associated driver is supplied on the Documentation & Drivers CD can must first be copied to a diskette.

Note

Please notice also the information in the electronic manuals of the controller. You can find these on the supplied Documentation and Drivers CD.

6. Follow the screen instructions until the Recovery functions window is displayed.
7. Create a partition using the WinPE tool as described in Section 12.5.2 "Setting up partitions for Windows operating systems", and format this partition. This partition then has to be activated.
8. Select "Start command prompt" in the Recovery functions window.
9. Set the appropriate drive letter in folder I386 and start "Winnt32.bat" from this folder

Note

After copying the Windows installation files, return to the "SIEMENS Simatic Recovery" main menu.

10. Close the Siemens SIMATIC Recovery window with the "Finish" button
11. The Windows installation is completed following an automatic restart of the system
12. Follow the instructions on the screen

12.5.6 Installing individual drivers

Introduction

The "Documentation and Drivers" CD contains the required drivers for the device.

Procedure

1. Start "Start.exe" in the root directory of the CD.
2. Follow the instructions displayed on the screen.

Note

For further information on reinstalling the drivers, go to <http://www.siemens.com/asis>, under "Support".

12.5.7 Operation of two hard disks

The two hard disks are configured as follows in the factory state of the computer:

Hard disk 0	Hard disk 1
Partition C: System, NTFS, 10 GB	Not configured
Partition D: Data, NTFS, remaining capacity	

You can use the two hard disks as a 2 HDD system.

12.5.7.1 2 HDD system

Depending on the device features, the Panel PC 877 can be equipped with two 2.5" (PATA) hard disk drives. The slave hard disk drive is not set up. This gives you the option of backing up your data to this hard disk. The two hard disk drives are operated as master or slave on the primary IDE controller of the basic module. Please refer to your order documentation for the capacities of the hard disks.

Booting from the slave hard disk

The master drive is the default boot drive. However, you may also boot the system from the slave drive.

In order to allow booting from the second hard disk drive, you need to set it up as primary boot device. Make the following settings in your BIOS Setup:

Select Boot > Hard Drive > <Drive name> e.g. FUJITSU MHT2030AT- (PS), then press the "+" "-" key to move it up in the boot order.

(PS) = Primary Slave, (PM) = Primary Master.

Notice

The drive letters for the partitions on both drives are assigned by the operating system used. You can change these in the Control Panel as required.

A defective hard disk drive may block the IDE bus. To be able to continue working with the functional hard disk drive, disconnect the defective drive from the IDE bus and change the jumper settings on the drive as required (master setting, see the label on the drive.)

12.5.7.2 RAID system with Promise Fast Track Controller TX2300

RAID 0 system

A RAID 0 system (Stripe) enables you to increase the read/write speed of your hard disk system. This configuration reduces the reliability of the drive system, however. RAID 0 is therefore not recommended and is omitted from the installation instructions.

RAID 1 system

A RAID 1 system (mirroring) enables you to increase the data security of your hard disk system. It involves copying (mirroring) the data to a second hard disk.

Each hard disk is operated on a separate SATA channel. The system can continue to operate even when a problem is detected on one of the hard disks. The data backed up on the RAID 1 network is retained. This data would be lost on a single drive or without RAID 1. RAID 1 therefore increases the availability of the system.

Controller designation:

- SATA-RAID controller of type Promise Fast Track TX 2300 for SATA drives

This is a RAID1 system configuration (mirroring with two hard disks). The hard disk drive are operated on separate channels of the RAID Controller. This enables the system to continue to operate on one bus even when there is a problem with a cable and therefore increases the availability of the system.

The RAID controller PCI card is installed in PCI slot 5 of the bus module.

Note

Information about the operation of the RAID system can be found in the Promise user manual on the Documentation and Drivers CD supplied.

Functions for RAID system management

The preinstalled software of the RAID system offers enhanced functions for using and managing the RAID system.

SATA-RAID software is started via "Start > Programs > Promise Array Management > Local PAM".

Access to the RAID is protected by user and password. Factory setting:

- User: Administrator
- Password: empty

Notice

The security functions of the RAID system are effective without launching the software. The RAID status is always indicated in the Windows status bar. In the event of an error, a hard disk can be duplicated by means of the RAID Controller BIOS or on the operating system level. It may take up to several hours to synchronize a new disk in the background, depending on the size of the hard disk and on the system load.

The redundant system state RAID Level 1 is reached again only after synchronization is completed.

Configuring a RAID 1 system

Prerequisites

- Two identical SATA hard disks; the primary hard disk contains the operating system and data (boot drive), the second hard disk is empty.
- If the DiagMonitor has been installed, the DiagMonitor Agent must be stopped. To exit the DiagMonitor agent, enter the command "NET STOP SNMP" in the DOS box.
- The Windows XP Professional or Windows 2000 Professional operating system installed in the factory state already includes the required drivers and the unconfigured RAID software (PAM TOOL).

Note

Re-starting the DiagMonitor agent

After the RAID 1 volume has been successfully created, you must start the DiagMonitor agent again. Enter the "NET START SNMP" commands in the DOS box.

If the primary hard disk does not have an operating system installed, follow the instructions provided by the section "Restoring the factory state of the software using the Restore DVD".

Comments about faults

A message from the "Promise Array Management" program is generated when a hard disk fails.

This message is also entered in the status bar of the Windows operating system.

Notice

Input delay

Depending on the load on the processor and the hard disk activity at the time, the system may become briefly overloaded when a disk fails due to the synchronization process.

In extreme cases, input from the keyboard and touchscreen may be delayed for a brief period.

Note

BIOS messages during startup

At the first restart / cold start following a hard disk failure or installation of a new hard disk (servicing), the RAID BIOS reports that the RAID functionality is no longer available and offers the appropriate operator options.

12.5.7.3 Installing the RAID Controller software

The procedure for installing the software can be found in the RAID user manual on the supplied Documentation and Drivers CD.

Note concerning Windows 2000 Professional / XP Professional

You need to select the type Promise FastTrack TX 2300 controller from the provided list when installing Windows 2000 Professional / XP Professional for the first time.

12.5.8 Installing burner and DVD software

The supplied CD provides information about installation of the burner and DVD software.

12.5.9 Backing up the hard disk

The device's hard disk is divided into two partitions, volumes C and D. The operating system is installed on volume C. Volume D can be used for user data.

Back up the complete hard disk regularly, for example, using "SIMATIC PC/PG Image Partition Creator". This software can be purchased as an accessory, Order No. 6ES7648-6AA03-0YX0.

Caution

Date errors writing to CD-RW

The quality of raw disc differs considerably. Data errors cannot, therefore, be entirely excluded. To be on the safe side, verify the data after writing it.

Alarm, error and system messages

13.1 Boot error messages

During startup (the boot process), the BIOS first performs a **Power On Self Test (POST)** and checks whether certain functional units of the PC are operating error-free. When an error occurs within this phase, the BIOS outputs a tone sequence (beep code) based on the current test result. The boot sequence is interrupted immediately if fatal errors occur.

If the POST does not return an error, the BIOS initializes and tests further functional units. In this startup phase, the graphics controller is initialized and any error messages are output to the screen.

The following lists the error messages from the system BIOS. For information on error messages output by the operating system or programs, refer to the corresponding manuals.

On-screen error messages

On-screen error message	Meaning / suggestions
Address conflict	Plug and Play problem. Contact your technical support team.
Combination not supported	Plug and Play problem. Contact your technical support team.
IO device IRQ conflict	Plug and Play problem. Contact your technical support team.
Invalid System Configuration Data	Plug and Play Problem <ul style="list-style-type: none"> • Set the RESET CONFIGURATION DATA option in the "Advanced" menu of Setup. • Contact your technical support team.
Allocation Error for ...	Plug and Play problem <ul style="list-style-type: none"> • Please undo the last hardware change. • Contact your technical support team.
System battery is dead. Replace and run SETUP	The battery on the CPU module is defective or dead. Contact your technical support team.
System CMOS checksum bad Run SETUP	Call up SETUP, adjust settings and save. If this message appears during each startup, contact your technical support team.
Failure Fixed Disk	Error accessing the hard drive. Check the SETUP settings. Contact your technical support team.

13.1 Boot error messages

On-screen error message	Meaning / suggestions
Keyboard error	Check whether the keyboard is properly connected.
Key seizure	Check whether a key on the keyboard has seized.
System RAM Failed at offset:	Memory error. Contact your technical support team.
Shadow RAM Failed at offset:	Memory error. Contact your technical support team.
Extended RAM Failed at offset:	Memory error. Contact your technical support team.
Failing Bits:	Memory error. Contact your technical support team.
Operating system not found	Possible causes: <ul style="list-style-type: none"> • No operating system present • Wrong drive addressed (disk in drive A/B) • Incorrect active boot partition • Wrong boot drive settings in SETUP • Hard disk is not connected / defective
Previous boot incomplete Default configuration used	Abort of the previous BOOT procedure, for example, due to a power failure. Adjust the settings in SETUP.
System cache error Cache disabled	Error in the CPU's cache module. Contact your technical support team.
Monitor type does not match CMOS Run SETUP	The monitor does not match the SETUP entries. Adapt the SETUP entries to the monitor.
System time-out	Hardware error. Contact your technical support team.
Real-time clock error	Clock chip error. Contact your technical support team.
Keyboard controller error	Keyboard error. Contact your technical support team.

13.2 Introduction to the BIOS beep codes

The device performs a self-test when it is switched on. If an error is detected during the POST (Power On Self Test), a series of beep signals are issued. The beep tones are a code for errors and are composed of 2 x 2 sequences.

Table 13-1 Converting the beep codes in a Hex display

Beep tones		Hex code
B	B	0
B	BB	1
B	BBB	2
B	BBBB	3
BB	B	4
BB	BB	5
BB	BBB	6
BB	BBBB	7
BBB	B	8
BBB	BB	9
BBB	BBB	A
BBB	BBBB	B
BBBB	B	C
BBBB	BB	D
BBBB	BBB	E
BBBB	BBBB	F

Example

Tone sequence	B	BBB	BBB	B
Hex code	2		8	
Meaning	Determine RAM size			

Special codes

The following special code are provided in addition to the beep codes:

Special code	Meaning
3x short	The <Ins> key is pressed during the system start: The on-board device installation is skipped. The on-board graphic controller is used as the default display.
1x long 8x short	Error reading the MPI system information. Contact customer service.
4x short	MPI-EEPROM programmed for the first time.
1x long 5x short	Ethernet error Contact customer service.
2x short	Error in checksum test of the BIOS: This can occur following a battery replacement or when the battery is empty.

13.3 BIOS beep codes

The following section lists the POST codes relevant to users in the sequence in which they occur: Contact Customer Support for all other POST codes.

Hex code of the beep codes	Meaning	Description	Remedy
16H	TP_CHECKSUM	BIOS checksum test	Service event
28H	TP_SIZE_RAM	Determine DRAM size	Replace memory modules
2AH	TP_ZERO_BASE	Set base RAM 64KB to 0	Replace memory modules
2CH	TP_ADDR_TEST	Check address busses	Replace memory modules
2EH	TP_BASERAML	BaseRam Low	Replace memory modules
30H	TP_BASERAMH	BaseRam High	Replace memory modules
38H	TP_SYS_SHADOW	BIOS is copied to DRAM	Replace memory modules
3AH	TP_CACHE_AUTO	Determine CPU cache	Exchange CPU
22H	TP_8742-TEST	Test keyboard controller	Check if keyboard is connected or defective
3CH	TP_ADV_CS_CONFIG	Configure the advanced chipset	Test by switching off the hardware components in Setup
49H	TP_PCI_INIT	Initialize the PCI interface	Test by switching off the hardware components in Setup or removing installed expansion modules from the bus module
55H	TP_USB_INIT	Activation of the USB hardware	Removal of USB devices
4AH	TP_VIDEO	Initialize the video interface	
5CH	TP_MEMORY_TEST	Test of the system memory	Replace memory modules
60H	TP_EXT_MEMORY	Test of the complete memory	Replace memory modules
62H	TP_EXT_ADDR	Test of the address busses	Replace memory modules
90H	TP_FDISK	Initialization and test of the hard disk hardware	Disconnect hard disk, replace if necessary
95H	TP_CD	Initialization and test of the CD hardware	Disconnect CD ROM, replace if necessary
98H	TP_ROM_SCAN	Search for BIOS expansions	Test by switching off the hardware components in Setup or removing installed expansion modules from the bus module
BCH	TP_PARITY	Test of the memory modules	Replace memory modules
00H		BIOS Power On Self Test completed. Loading operating system	

Special codes

The following Beep codes are available in addition to the listed POST codes:

- **3 x short** INSERT key is pressed on system start:
If an external graphics card on the bus board is not detected, you can try to activate it by pressing the INSERT key.
The "INSERT" key activates special enumerations for activating a PCI VGA card.
- **1 x long 8 x short** Error on reading the MPI system information:
Please contact Customer Support
- **4 x short** MPI firmware has been updated:
This can occur once following a BIOS update.
- **2x short** Error in checksum test of the BIOS:
This can occur following a battery replacement or when the battery is empty.

Troubleshooting/FAQs

14.1 General problems

This chapter provides you with tips on how to localize and troubleshoot frequently occurring problems.

Problem	Possible causes	To correct or avoid error
The device is not operational	There is no power supply to the device.	<ul style="list-style-type: none"> • Check the power supply, the network cable and the power plug. • Check whether the On/Off switch is in the correct position.
	Device is being operated outside the specified ambient. conditions	<ul style="list-style-type: none"> • Check the ambient conditions. • After transport in cold weather, wait approximately 12 hours before switching on the device.
The mouse pointer does not appear on the screen.	The mouse driver is not loaded.	1. Check whether the mouse driver is properly installed and present when you start the application program.
	The mouse is not connected.	1. Check whether the mouse lead is connected to the system unit. If you are using an adapter or an extension for the mouse lead, check this plug-in connection too. After these checks and measures, if the mouse pointer still does not appear on the screen, please contact Technical Customer Support.
Wrong time and/or date on the PC.		<ol style="list-style-type: none"> 1. Press <F2> within the boot sequence to open the BIOS Setup. 2. Set the time and date in the setup menu.
Although the BIOS setting is OK, the time and data are still wrong.	The backup battery is dead.	In this case, please contact your technical support team.
USB device not responding.	The USB ports are disabled in your BIOS.	Use a different USB port or switch the port on.
	USB 2.0 device connected but USB 2.0 is disabled.	Enable USB 2.0.
	Operating system does not support the USB port.	Enable USB Legacy Support for the mouse and keyboard. For all other devices you need USB drivers for the specific operating system.
DVD: The front loader does not open.	The device is switched off or the open/close button is disabled by a software application.	<p>Emergency removal of the data medium:</p> <ol style="list-style-type: none"> 1. Switching off the device 2. Insert a pointed object, a pin for example, or an opened paper clip into the emergency extraction opening of the drive. Apply slight pressure to the contact until the front loader opens. 3. Pull the loader further out.

14.2 Problems when Using Modules of Third-party Manufacturers

Problem	Possible causes	To correct or avoid error
The PC crashes during startup	<ul style="list-style-type: none"> • I/O addresses are assigned twice. • Hardware interrupts and/or DMA channels are assigned twice. • Signal frequencies or signal levels are incorrect. • Connector assignments deviate. • "Reset Configuration" in BIOS SETUP has not been carried out. 	<p>Check your computer configuration:</p> <ul style="list-style-type: none"> • If the computer configuration corresponds with factory state, please contact your technical support team. • If the computer configuration has changed, restore the original factory settings. Remove all third-party modules, then restart the PC. If the error no longer occurs, the third-party module was the cause of the fault. Replace this module with a Siemens module or contact the module supplier. • Force a "Reset Configuration" using the BIOS setup. <p>If the PC still crashes, contact your technical support team.</p>
	<ul style="list-style-type: none"> • If the performance of the external 24 V power supply is insufficient 	<ul style="list-style-type: none"> • use a larger power supply.

14.3 Temperature limits

Cause

If the device is used for its intended purpose, the temperature threshold values are not exceeded or fallen below. When the LED "Temp" on the upper left side of the operator control unit lights up, check the following:

- Are the fan apertures covered?
- Has the fan failed (check speed display in the SOM or on the DiagMonitor)?
- Is the ambient temperature higher than the allowed value (see "Technical data")?
- Is the total output of the power supply within the specified limit?
- Are the heatsinks inside the PC covered with dust?

Remedy

The temperature error is retained until the temperatures have fallen below the thresholds and you have acknowledged the error alarm in the SOM program. Click on the button with the "small broom" icon. When the error alarm has been acknowledged, the "TEMP" LED on the devices goes off and the title bar and "SOM" icon in the status bar of the SOM program changes from red to green. If you have not installed the SOM program or DiagMonitor, you must restart the PC.

Technical data

15.1 General technical data

General technical data	
AC device: Supply voltage	100 to 240 V AC (85 to 265 V AC)
DC device: Supply voltage	24 V DC (20.4 to 28.8 V DC) SELV
AC device: Frequency	50 - 60 Hz (47 to 63 Hz)
Transient voltage interruption according to Namur	AC device: At least 20 ms for 93 to 264 V at most 10 events per hour; recovery time of at least 1 s DC device: no buffering
AC device: Max. power consumption of complete unit at 240 W secondary	360 W primary with approx. 65% efficiency
DC device: Max. power consumption of complete unit at 180 W secondary	265 W primary with approx. 70% efficiency
AC device: max. current output	+5 V/25 A *) +3.3 V/10 A *) *) 155 W total allowed +12 V/12.2 A peak 14.0A -12 V/0.8 A -5 V/0.5 A limited to >0.8 A +5 Vaux/2 A peak 2.5 A The total voltage amounts to max. 230 W.
DC device: max. current output	+5 V/22 A *) +3.3 V/16 A *) *) 140 W total allowed +12 V/4.4 A peak 8.0 A -12 V/0.5 A -5 V/0.5 A +5 Vaux/1 A The total voltage amounts to 180 W.
Noise emission	< 55 dB(A) according to DIN 45635-1
Degree of protection for complete unit on rear	IP 20
Degree of protection on front with tension jack mouniting	IP 65
Degree of protection on front with screw mouniting	IP 54

15.1 General technical data

General technical data	
Electromagnetic compatibility (EMC)	
AC device: Emitted interference	EN 55011 Class A, EN 61000-3-2 Class D EN 61000-3-3
DC device: Emitted interference	EN 55022 Class A
Noise immunity: Mains borne disturbance variables on supply lines	± 2 kV; according to IEC 61000-4-4; Burst ± 1 kV; according to IEC 61000-4-5; Surge sym. ± 2 kV; according to IEC 61000-4-5; Surge asym.
Noise immunity on signal lines	± 1 kV; according to IEC 61000-4-4; Burst; length < 3 m ± 2 kV; according to IEC 61000-4-4; Burst; length > 3 m ± 2 kV; according to IEC 61000-4-5; surge; length > 30 m
Immunity to discharges of static electricity	± 6 kV contact discharge according to IEC 61000-4-2 ± 8 kV air discharge according to IEC 61000-4-2
Immunity to RF interference	10 V/m 80-1000 MHz, 80% AM according to IEC 61000-4-3 10 V/m 900 MHz and 1.89 GHz, 50% ED according to IEC 61000-4-3 10 V/m 9 KHz-80 MHz according to IEC 61000-4-6
Magnetic field	30 A/m, 50 Hz according to IEC 61000-4-8
Climatic conditions	
Temperature <ul style="list-style-type: none"> • Operation • Installed in cabinet: <ul style="list-style-type: none"> – For external temperature of 40 °C – For external temperature of 45 °C • Storage, transportation • Gradient 	Tested to IEC 60068-2-1, IEC 60068-2-2, IEC 60068-2-14 <ul style="list-style-type: none"> • + 5 °C up to + 45 °C • Internal temperature max. 50 °C • Internal temperature max. 45 °C • -20 °C to +60°C • max. 10° C/h in operation, 20° C/h storage, no condensation
Relative humidity <ul style="list-style-type: none"> • Operation • Storage/transport • Gradient 	Tested to IEC 60068-2-78, IEC 60068-2-30 <ul style="list-style-type: none"> • 5% to 80 % at 25° C, no condensation • 5% to 95% at 25° C, no condensation • Maximum 10° C/h, no condensation
Mechanical environmental conditions	
Vibration <ul style="list-style-type: none"> • Operation²⁾ • Storage/transport 	tested to DIN IEC 60068-2-6 <ul style="list-style-type: none"> • 10 to 58 Hz: 0.075 mm, 58 to 500 Hz: 9.8 m/s² = 1g • 5 to 9 Hz: 3.5 mm, 9 to 500 Hz: 9.8 m/s² = 1g
Resistance to shock <ul style="list-style-type: none"> • Operation²⁾ • Storage/transport 	Tested according to IEC 60068-2-27, IEC 60068-2-29 <ul style="list-style-type: none"> • 50 m/s² approx. 5 g, 30 ms • 250 m/s² approx. 25 g, 6 ms

General technical data	
Motherboard	
Processor	Intel ® Pentium 4 2.8 GHz Intel ® Celeron 2 GHz Intel ® Pentium 4 Mobile 2.2 GHz
Internal processor cache	Intel ® Pentium 4 2.8 GHz, 512 KB Intel ® Celeron 2 GHz, 128 KB Intel ® Pentium 4 Mobile 2.2 GHz, 512 KB
Front Side Bus	Intel ® Pentium 4 2.8 GHz, 533 MHz Intel ® Celeron 2 GHz, 400 MHz Intel ® Pentium 4 Mobile 2.2 GHz, 400 MHz
Main memory	2 sockets maximum 2 GB SDRAM DDR See order documentation for expansion memory
Free expansion slots	2 shared ISA/PCI, long 2 x PCI, long 1 ISA, long
Max. permitted current consumption per ISA slot	5 V/ 2 A, 12 V/ 0.3 A, -12 V/ 0.05 A
Max. permitted current consumption per PCI slot	5 V/ 2 A or 3.3 V/ 2A, 12 V/ 0.3 A, -12 V/ 0.05 A
Permitted total power consumption for all slots	The total power consumption of all slots may not exceed 50 W.
Disk drives	
Floppy disk drive	3.5"; 1.44 MB
Hard disk	3.5" EIDE, UDMA, see order documentation for hard disk capacity 2.5" SATA with RAID controller depending on the device features
Optical drive ²⁾	EIDE, UDMA33, for information on features, refer to the order forms.
Interfaces	
COM1	Serial interface 1, 25-pin sub-D connector
COM2	Serial interface 2, 9-pin -Sub-D connector
LPT1	Parallel interface, standard mode, EPP mode Connection for parallel interface printer
DVI	Port for external CRT / LCD monitor
Keyboard	PS/2 keyboard connection
Mouse	PS/2 mouse port
USB 2.0 ⁶⁾	2 x externally on interface side 1 x on front of the control unit ⁵⁾

15.1 General technical data

General technical data				
PROFIBUS/MPI interface electrically isolated ³⁾ <ul style="list-style-type: none"> • Transmission rate • Mode groups • Physical port <ul style="list-style-type: none"> – Memory address area – Interrupts 		9-pin sub-D socket <ul style="list-style-type: none"> • 9.6 Kbps to 12 Mbps, configured per software • Electrically isolated: Data channels A, B Control channels RTS AS, RTS_PG 5 V power supply (max. 90 mA) • Grounded: Shielding of the DP12 cable • RS485, electrically isolated <ul style="list-style-type: none"> – Configured automatically – Configured automatically 		
Ethernet		Ethernet interface (RJ45), VIA MAC. VT6103 PHy		
Status displays on the device				
Control unit		<ul style="list-style-type: none"> • Power LED • Temperature LED 		
Computer unit		<ul style="list-style-type: none"> • Ethernet LEDs • Floppy disk drive LED • Optical drive LED 		
Display				
Graphics controller		VIA ProSavage8		
Graphics memory		Graphics memory 8, 16 or 32 MB taken from main memory		
Resolutions/frequencies/colors		CRT: up to 1600x1200 at 60 Hz / 16-bit color depth CRT: 1280 x 1024 at 100 Hz / 32-bit color depth LCD: 1280 x 1024 / 18-bit		
Color display ⁴⁾	12" TFT Key front	15" TFT Key front	15" TFT Touch screen	19" TFT Touch screen
Resolution	800 x 600	1024 x 768	1024 x 768	1280 x 1024
Contrast ratio, typ.	600:1	450:1	450:1	700:1
Max. light density cd/m ² , typ.	350	250	250	300
Horizontal viewing angle right/left/typ./min.	70° / 60°	60° / 50°	60° / 50°	typically 80°
Vertical viewing angle above / typ. / min.	45° / 35°	40° / 30°	40° / 30°	typically 80°
Vertical viewing angle below / typ. / min.	55° / 45°	60° / 35°	60° / 35°	typically 80°

General technical data				
Panel PC 877	12" TFT Key front	15" TFT Key front	15" TFT Touch screen	19" TFT Touch screen
Service life of backlighting	50,000 h for 24 hours per day usage, temperature dependent, 50% residual brightness remains			
Membrane keyboard with alphanumeric and numeric keys	X		—	
Function keys	36 with LED		—	
Direct control key module	optional		—	
Actuating force (test pen 3 mm with 3 mm radius)	max. 3 N		—	
Cycles (operation)	> 1 million		—	
Resistive analog touch screen	—		X	
Touch force (with test pen 2 mm diameter)	—		5 N	
Slide-in labels for function keys	X		—	
Front-mounted integrated mouse	X		—	
Power losses *)				
Efficiency of the power supply 86%	12" key panel	15" key panel	15" touch screen	19" touch screen
Control unit	30 W	30 W	30 W	53 W
Computer unit	90 W	90 W	90 W	90 W
PCI cards (17.5 W each)	87.5 W	87.5 W	87.5 W	87.5 W
Panel PC 877	115 W	115 W	115 W	135 W
Panel PC with 5 PCI plug-in cards	207.5 W	207.5 W	207.5 W	230.5 W
*) The values specified apply for the maximum expansion of the device				
Weight				
Panel PC 877	12" TFT Key front	15" TFT Key front	15" TFT Touch screen	19" TFT Touch screen
Complete unit	14.69 kg	18.81 kg	17.24 kg	19.6 kg
Control unit	4.89 kg	9.01 kg	7.44 kg	9.80 kg

15.1 General technical data

General technical data		
Safety		
Protection class	Protection class I to IEC 60536, i.e.: Device with PE ground terminal	
Standards	IEC 60950-1, EN 60950-1, DIN EN 60950-1, EN 61131-2	
Approvals	AC device: cULus in accordance with UL 60950-1 DC device: cULus in accordance with UL 508	
Conformity	CE	
Degree of protection	With clamp attachment, encircling seal and pressed-on plastic cap for USB interface ⁵⁾	IP 65, NEMA 4
	With screw attachment	IP 54
Liability of product nonconformance	24 months	
Quality assurance	to ISO 9001	

1) Limitations for optical drives:

Burner operation is only allowed without external disruptions and at an ambient temperature between +5° C and +40° C.

2) Limitation for optical drives:

10 to 58 Hz: 0.019 mm / 58 to 500 Hz: 2.5 m/s² approx. 1/4 g. Burner operation is only allowed without external disruptions.

3) Electrically isolated within the safety extra-low voltage circuit, SELV.

4) A small number of faults in the display is unavoidable. However, the displays do comply with the described quality standards of the ISO standard 13406-2, class 2.

Bad pixels	Permissible number
Permanently bright and permanently dark pixels	≤ 12
Permanently bright, green pixels	≤ 5

5) The front USB interface cannot be used in some device variants.

6) USB 2.0 standard.

Permissible temperature ranges depending on the installation method

Panel PC 877			
Complete unit	Internal cabinet temperature	Ambient temperature cabinet	Comment
Installed in cabinet different temperatures	50 °C	40 °C	1)4)
Installed in cabinet Same temperature inside and outside	45 °C	45 °C	2)4)
Computer unit and control unit separated, using Remote Kit			
12" control unit	50 °C	45 °C	
15" control unit	50 °C	45 °C	
19" v	50 °C	45 °C	5)
Computer unit, Intel ® Pentium 4 Mobile 2.2 GHz, 400 MHz	55 °C	-	3)4)

These values are applicable for vertical installation and when air is flowing through the cabinet.

- 1) Max. PCI load 50 W
- 2) Full expansion, max. PCI load 75 W (5 slots)
- 3) PCI modules are not permitted
- 4) Above 40 °C, optical drives must not be operated
- 5) When the 19" front is operated at ambient temperatures between 45 °C and 50 °C, the USB interface of the Remote Kit (rear USB interface) must not be used.

15.2 Power requirements of the components

Standard system

Components	Voltage					
	+5 V	+3.3 V	+12 V	-5 V	-12 V	5 Vaux
Motherboard	1.3 A	4.8 A	0.2 A		0.03 A	0.3 A
Intel ® Pentium 4 Desktop or Celeron processor with active heat sink			5.8 A			
Intel ® Pentium 4 Mobile processor with active heat sink	7 A					
Diskdrive	0.6 A					
Hard disks-drive; 1 x 3.5"	0.3 A		0.5 A			
DVD-ROM/CD-RW drive	0.9 A		0.8 A			
Equipment fan			0.2 A			
RAID controller ³⁾	0.5 A					
ISA-PCI slots ¹⁾ (total)	10 A		1.5 A	0.5 A	0.25 A	0.25 A
Front panel port	2.5 A	0.9 A	4.2 A			
Individual currents (max. permitted) on DC power supply	22 A ²⁾	16 A ²⁾	4.4 A	0.5 A	0.5 A	1 A
Individual currents (max. permitted) on AC power supply	25 A ³⁾	10 A ³⁾	12.2 A	0.5 A	0.8 A	2 A
Permitted total power consumption on DC power supply	180 W					
Permitted total power consumption on AC power supply	230 W					

1) The ISA/PCI slots can be operated with the same power consumption on both 5 V and 3.3 V.

2) The max. permitted accumulated power of +5 V and + 3.3 V is 140 W.

3) The max. permitted accumulated power of +5 V and + 3.3 V is 155 W.

15.3 Device with AC voltage supply

Technical data

Input voltage	100 to 240 V AC (85 to 264 V AC)
Frequency	50 - 60 Hz
Power consumption	360 W
Power failure buffering	20 ms
Maximum continuous output power	230 W
Degree of protection	IP20 (in installed state)
Protection class	VDE 0106

Output voltages

Voltage	Max. current
+ 12 V	12.2 A peak 14 A
- 12 V	0.8 A
+ 5 V	25 A ¹
- 5 V	0.5 A
+ 3.3 V	10 A ¹
+ 5 V _{aux}	2 A peak 2.5 A

¹ The max. permitted accumulated power of the +5 V and + 3.3 V is 155 W.

Power Good Signal of the AC power supply

Power-Good-Signal:

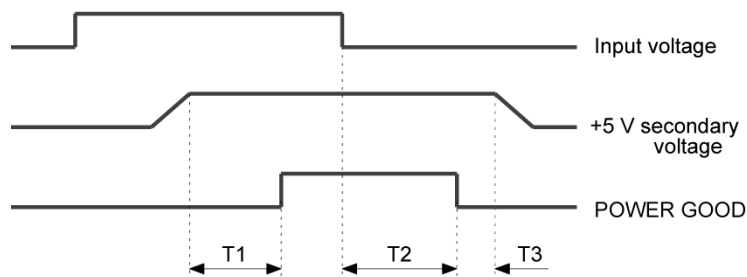

T1:	preset time	100 ... 500 ms
T2:	hold-up time	20 ms minimum
T3:	save time	1 ms minimum

15.4 Device with DC voltage supply

Technical data

Input voltage	24 V DC (20.4 to 28.8 V DC)
Power consumption	265 W
Power failure buffering	1 ms at nominal voltage
Maximum continuous output power	180 W
Degree of protection	IP20 (in installed state)
Protection class	VDE 0106

Output voltages

Voltage	Max. current
+ 12 V	4.4 A
- 12 V	0.5 A
+ 5 V	22 A ¹
- 5 V	0.5 A
+ 3.3 V	16 A ¹
+ 5 V _{aux}	1 A

¹ The max. permitted accumulated power of the +5 V and + 3.3 V is 140 W.

Power Good Signal of the DC power supply

Power-Good-Signal:

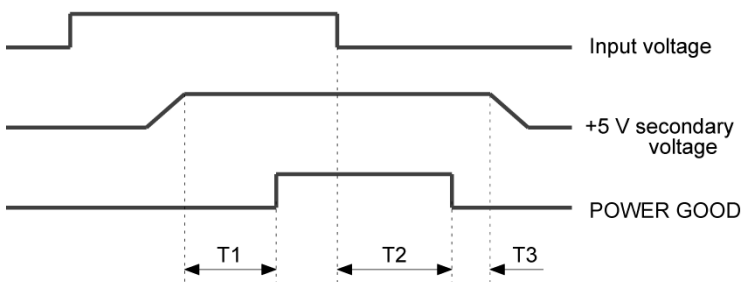

T1:	preset time	100 ... 500 ms
T2:	hold-up time	not specified
T3:	save time	1 ms minimum

15.5 Keyboard table

Key codes

The following table applies only to control units with key panels. It contains all characters that can be entered in SIMATIC KeyTools in the "Key code table" area and under "User specific". The character that is triggered by pressing a specific key is listed in the "Display/function" column. Further information is available in the documentation for SIMATIC KeyTools on the "Documentation and Drivers" CD.

Name	Code (Hex) 0x	Check-box	Display/function
a A	4	—	a
		L Shift/R Shift	A
		R Alt	á
		R Alt+L Shift/R Shift	Á
b B	5	—	b
		L Shift/R Shift	B
c C	6	—	c
		L Shift/R Shift	C
		R Alt	©
		R Alt+L Shift/R Shift	ç
		L Ctrl/R Ctrl	Copy
d D	7	—	d
		L Shift/R Shift	D
		R Alt	ð
		R Alt+L Shift/R Shift	Ð
e E	8	—	e
		L Shift/R Shift	E
		R Alt	é
		L Shift/R Shift	É
		L Gui/R Gui	Start Windows Explorer
f F	9	—	f
		L Shift/R Shift	F
		L Gui/R Gui	Find folder and file
g G	0A	—	g
		L Shift/R Shift	G
h H	0B	—	h
		L Shift/R Shift	H

15.5 Keyboard table

Name	Code (Hex) 0x	Check-box	Display/function
i l	0C	—	i
		L Shift/R Shift	l
		R Alt	í
		R Alt+L Shift/R Shift	í
j J	0D	—	j
		L Shift/R Shift	J
k K	0E	—	k
		L Shift/R Shift	K
l L	0F	—	l
		L Shift/R Shift	L
		R Alt	ø
		R Alt+L Shift/R Shift	Ø
m M	10	—	m
		L Shift/R Shift	M
		R Alt	μ
		L Gui/R Gui	Minimize all windows
n N	11	—	n
		L Shift/R Shift	N
		R Alt	ñ
		R Alt+L Shift/R Shift	Ñ
o O	12	—	o
		L Shift/R Shift	O
		R Alt	ó
		R Alt+L Shift/R Shift	Ó
		L Ctrl/R Ctrl	Open
p P	13	—	p
		L Shift/R Shift	P
		R Alt	ö
		R Alt+L Shift/R Shift	Ö
		L Ctrl/R Ctrl	Printing
q Q	14	—	q
		L Shift/R Shift	Q
		R Alt	ä
		R Alt+L Shift/R Shift	Ä

Name	Code (Hex) 0x	Check-box	Display/function
r R	15	—	r
		L Shift/R Shift	R
		R Alt	@
		L Gui/R Gui	Display "Run" dialog
s S	16	—	s
		L Shift/R Shift	S
		R Alt	ß
		R Alt+L Shift/R Shift	§
		L Ctrl/R Ctrl	Save
t T	17	—	t
		L Shift/R Shift	T
		R Alt	þ
		R Alt+L Shift/R Shift	þ
u U	18	—	u
		L Shift/R Shift	U
		R Alt	ú
		R Alt+L Shift/R Shift	Ú
v V	19	—	v
		L Shift/R Shift	V
		L Ctrl/R Ctrl	Paste
w W	1A	—	w
		L Shift/R Shift	W
		R Alt	â
		R Alt+L Shift/R Shift	Â
x X	1B	—	x
		L Shift/R Shift	X
		L Ctrl/R Ctrl	Cut
y Y	1C	—	y
		L Shift/R Shift	Y
		R Alt	ÿ
		R Alt+L Shift/R Shift	ÿ
z Z	1D	—	z
		L Shift/R Shift	Z
		R Alt	æ
		R Alt+L Shift/R Shift	Æ
		L Ctrl/R Ctrl	

15.5 Keyboard table

Name	Code (Hex) 0x	Check-box	Display/function
1 !	1E	—	1
		L Shift/R Shift	!
		R Alt	i
		R Alt+L Shift/R Shift	'
2 @	1F	—	2
		L Shift/R Shift	@
		R Alt	²
3 #	20	—	3
		L Shift/R Shift	#
		R Alt	³
4 \$	21	—	4
		L Shift/R Shift	\$
		R Alt	¤
		R Alt+L Shift/R Shift	£
5 %	22	—	5
		L Shift/R Shift	%
		R Alt	€
6 ^	23	—	6
		L Shift/R Shift	^
		R Alt	¼
7 &	24	—	7
		L Shift/R Shift	&
		R Alt	½
8 *	25	—	8
		L Shift/R Shift	*
		R Alt	¾
9 (26	—	9
		L Shift/R Shift	(
		R Alt	'
0)	27	—	0
		L Shift/R Shift)
		R Alt	'
Return	28	—	Return
Escape	29	—	Escape
Backspace	2A	—	Backspace
Tab	2B	—	Tab
Space	2C	—	Space

Name	Code (Hex) 0x	Check-box	Display/function
- _	2D	—	-
		L Shift/R Shift	_
		R Alt	¥
= +	2E	—	=
		L Shift/R Shift	+
		R Alt	×
		R Alt+L Shift/R Shift	÷
[{	2F	—	[
		L Shift/R Shift	{
		R Alt	«
] }	30	—]
		L Shift/R Shift	}
		R Alt	»
\	31	—	\
		L Shift/R Shift	
		R Alt	¬
		R Alt+L Shift/R Shift	¡
Europe 1	32	—	Europe 1
; :	33	—	;
		L Shift/R Shift	:
		R Alt	¶
		R Alt+L Shift/R Shift	°
' "	34	—	'
		L Shift/R Shift	"
		R Alt	'
		R Alt+L Shift/R Shift	“
‘ ~	35	—	‘
		L Shift/R Shift	~
, <	36	—	,
		L Shift/R Shift	<
		R Alt	ç
		R Alt+L Shift/R Shift	Ç
. >	37	—	.
		L Shift/R Shift	>
/ ?	38	—	/
		L Shift/R Shift	?
		R Alt	¿

Name	Code (Hex) 0x	Check-box	Display/function
Caps Lock	39	—	Caps Lock
F1	3A	—	F1
		L Shift/R Shift	F13
		L Ctrl/R Ctrl	S5
F2	3B	—	F2
		L Shift/R Shift	F14
		L Ctrl/R Ctrl	S6
F3	3C	—	F3
		L Shift/R Shift	F15
		L Ctrl/R Ctrl	S7
F4	3D	—	F4
		L Shift/R Shift	F16
		L Ctrl/R Ctrl	S8
F5	3E	—	F5
		L Shift/R Shift	F17
		L Ctrl/R Ctrl	S9
F6	3F	—	F6
		L Shift/R Shift	F18
		L Ctrl/R Ctrl	S10
F7	40	—	F7
		L Shift/R Shift	F19
		L Ctrl/R Ctrl	S11
F8	41	—	F8
		L Shift/R Shift	F20
		L Ctrl/R Ctrl	S12
F9	42	—	F9
		L Shift/R Shift	S1
		L Ctrl/R Ctrl	S13
F10	43	—	F10
		L Shift/R Shift	S2
		L Ctrl/R Ctrl	S14
F11	44	—	F11
		L Shift/R Shift	S3
		L Ctrl/R Ctrl	S15
F12	45	—	F12
		L Shift/R Shift	S4
		L Ctrl/R Ctrl	S16
Print Screen, FN+INS	46	—	Print Screen, FN+INS
Scroll Lock	47	—	Scroll Lock
Break, Ctrl+Pause	48	—	Break, Ctrl+Pause
Pause	48	—	Pause
Insert	49	—	Insert

Name	Code (Hex) 0x	Check-box	Display/function
Home	4A	—	Home
Page Up	4B	—	Page Up
Delete	4C	—	Delete
End	4D	—	End
Page Down	4E	—	Page Down
Right Arrow	4F	—	Right Arrow
Left Arrow	50	—	Left Arrow
Down Arrow	51	—	Down Arrow
Up Arrow	52	—	Up Arrow
Num Lock	53	—	Num Lock
Keypad /	54	—	Keypad /
Keypad *	55	—	Keypad *
Keypad -	56	—	Keypad -
Keypad +	57	—	Keypad +
Keypad Enter	58	—	Keypad Enter
Keypad 1 End	59	—	Keypad 1 End
Keypad 2 Down	5A	—	Keypad 2 Down
Keypad 3 PageDn	5B	—	Keypad 3 PageDn
Keypad 4 Left	5C	—	Keypad 4 Left
Keypad 5	5D	—	Keypad 5
Keypad 6 Right	5E	—	Keypad 6 Right
Keypad 7 Home	5F	—	Keypad 7 Home
Keypad 8 Up	60	—	Keypad 8 Up
Keypad 9 PageDn	61	—	Keypad 9 PageDn
Keypad 0 Insert	62	—	Keypad 0 Insert
Keypad . Delete	63	—	Keypad . Delete
Europe 2	64	—	Europe 2
App	65	—	App
Keyboard Power	66	—	Keyboard Power
Keypad =	67	—	Keypad =
F13	68	—	F13
F14	69	—	F14
F15	6A	—	F15
F16	6B	—	F16
F17	6C	—	F17
F18	6D	—	F18
F19	6E	—	F19
F20	6F	—	F20
F21	70	—	F21
F22	71	—	F22
F23	72	—	F23
F24	73	—	F24

Name	Code (Hex) 0x	Check-box	Display/function
Left Control	E0	—	Left Control
Left Shift	E1	—	Left Shift
Left Alt	E2	—	Left Alt
Left GUI	E3	—	Left GUI
Right Control	E4	—	Right Control
Right Shift	E5	—	Right Shift
Right Alt	E6	—	Right Alt
Right GUI	E7	—	Right GUI

Dimension drawings

16.1 Panel PC 877 dimensional drawing

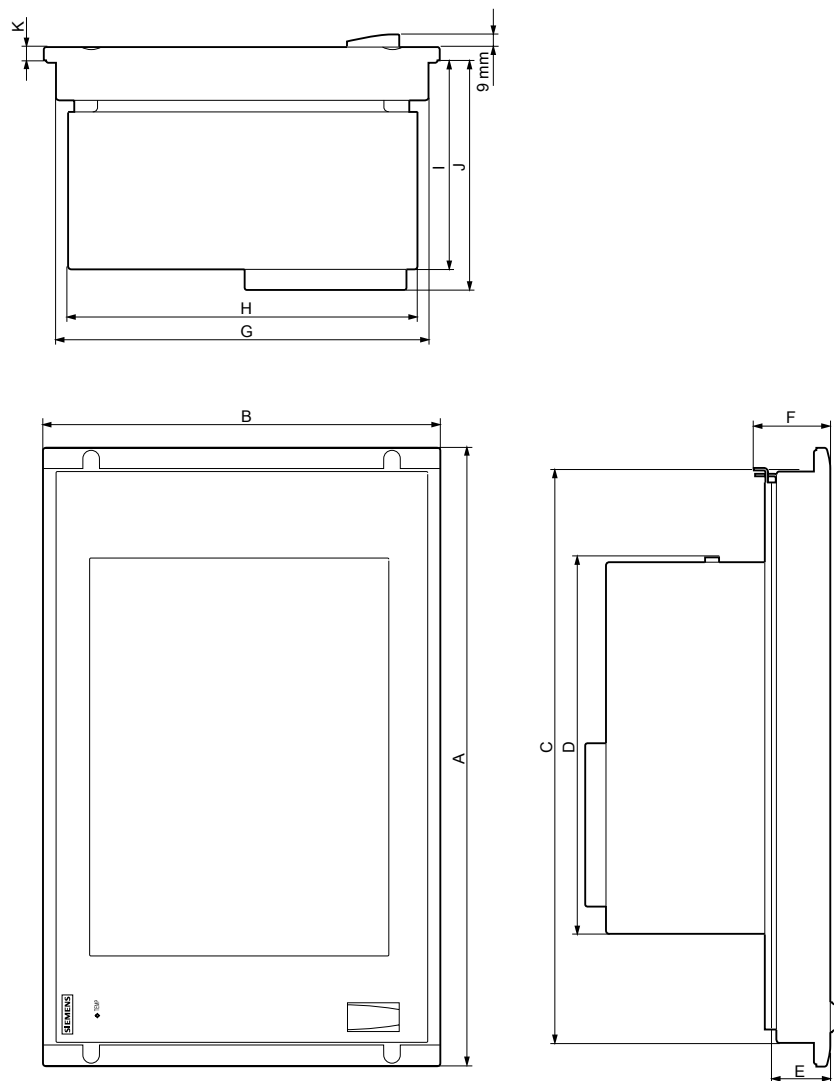

Figure 16-1 Panel PC 877 dimension drawing

16.1 Panel PC 877 dimensional drawing

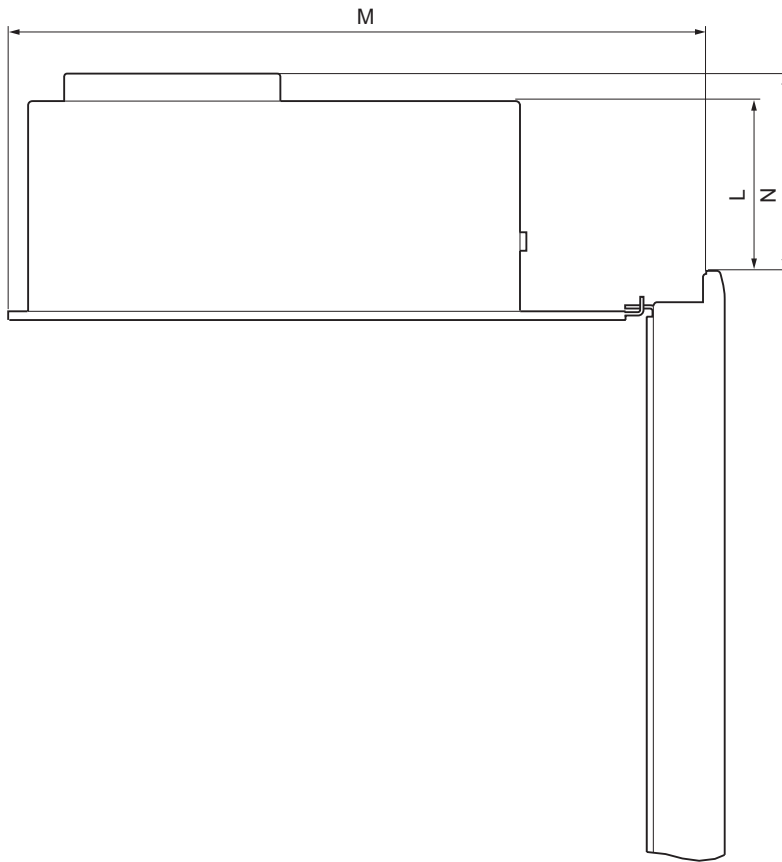
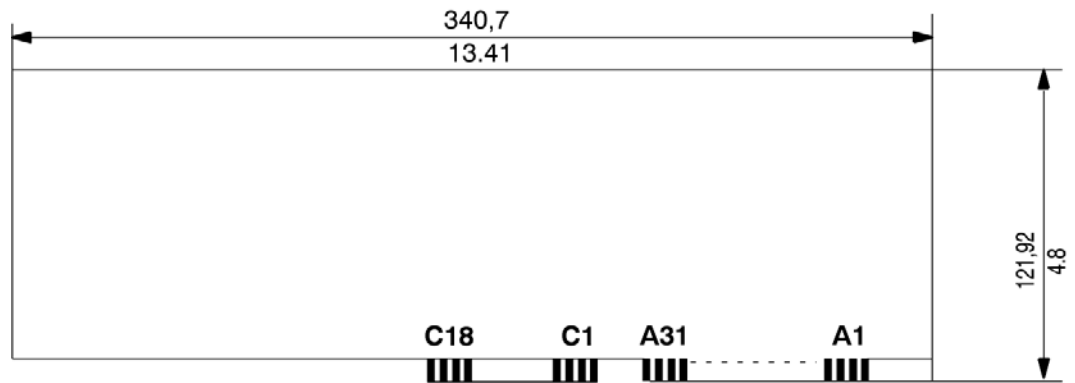

Figure 16-2 Panel PC 877 dimension drawing, computer unit swung away from control unit

Table 16-1 Panel PC 877 dimensions in mm

Control unit	Key panels		Touch screen front	
	12" TFT	15" TFT	15" TFT	19" TFT
A	482,6	482,6	482,6	482,6
B	310,3	354,8	310,3	400,0
C	447,2	447,2	450,0	450,0
D	392,8	392,8	392,8	392,8
E	30,8	49,8	46,6	56,1
F	39,8	59,8	58,6	68,1
G	288,3	324,4	288,3	378,0
H	285	285	285	285
I	191,4	210,4	208,2	216,9
J	208,9	227,9	225,7	234,4
K	10,5	10,5	10,5	10,8
L	145,7	146,7	145,8	139,8
M	460,8	479,8	476,6	485,8
N	163,2	164,2	163,3	157,3

16.2 Dimensional drawings for the installation of expansion modules



Dimensions: $\frac{\text{mm}}{\text{Inch}}$

Figure 16-3 AT module

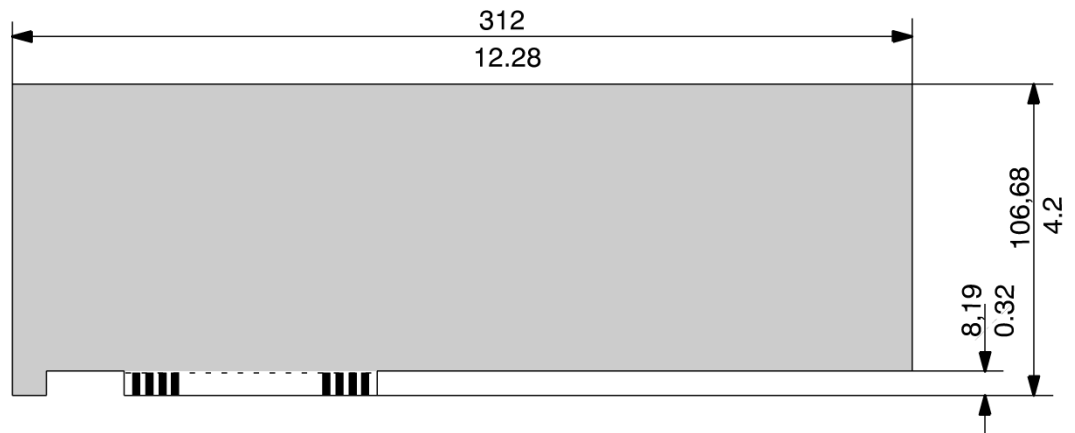

Dimensions: $\frac{\text{mm}}{\text{Inch}}$

Figure 16-4 Long format PCI module

Detailed descriptions

17.1 Motherboard

17.1.1 Structure and functions of the motherboard

The essential components of the motherboard are the processor and the chip set, two slots for memory modules, internal and external interfaces and the Flash BIOS.



(1)	Processor heat sink with fan
(2)	Two memory module slots
(3)	Slot for the bus board

17.1.2 Technical features of the motherboard

Component / interface	Description	Characteristics
Chip set	Single chip set	VIA P4N266A (VT8703A and VT8235)
BIOS	Update by means of software	Phoenix NuBIOS V4, modified by Siemens
CPU	Intel ® Pentium 4 / Mobile P4 / Intel ® Celeron (design mPGA478)	Upgradable <ul style="list-style-type: none"> Multimedia support On-board L2-Cache with 512 K / 512 K / 128 K
Memory	2 DIMM module slots, max. 1 GB/DIMM	<ul style="list-style-type: none"> 64-bit data bus width 3.3 V SDRAM DDR266 in accordance with PC2100 specification Up to 512 Mbit chip size on the module 66/100/133 MHz bus clock ³⁾ from 128 MB to 2 GB variable
Graphic	integrated in chip set	<ul style="list-style-type: none"> Compatible with Via ProSavage 8, graphics memory 8, 16 or 32 MB taken from main memory DVI interface (X303) CRT: <ul style="list-style-type: none"> Up to 1600x1200 pixels, 60Hz, 16-bit color. Up to 1280x1024 pixels, 100Hz, 32-bit color. LCD: <ul style="list-style-type: none"> LVDS or DVI up to 1280x1024 / 18-bit TFT
Hard disk drive ⁴⁾ [Primary EIDE interface]	As master or slave on ATA 33/66/100 mode	<ul style="list-style-type: none"> Ultra-DMA-capable
CD-ROM ⁴⁾ DVD-ROM/CD-RW ⁴⁾	Master on secondary EIDE interface	<ul style="list-style-type: none"> DMA-capable
Floppy ⁴⁾	FD drive interface	<ul style="list-style-type: none"> 1.44 MB
Keyboard	PS/2 keyboard interface	<ul style="list-style-type: none"> Standard
Mouse	PS/2 mouse interface	<ul style="list-style-type: none"> Standard
Serial	COM1/25-pin COM2/9-pin	<ul style="list-style-type: none"> V.24
Parallel	Standard, bidirectional, EPP mode	<ul style="list-style-type: none"> 25-pin subminiature connector
PROFIBUS/MPI ²⁾	Communication interface SIMATIC S7	<ul style="list-style-type: none"> Floating¹ CP 5611-compatible 12 Mbaud
USB	Universal Serial Bus	<ul style="list-style-type: none"> High-current (500 mA) USB ports, 5 channels: 2 x external at the interface side, 3 x internal
Ethernet	10BaseT/100Base-TX (compatible with VIA Rhein family)	<ul style="list-style-type: none"> 10/100 MB, floating ¹⁾

- 1) Galvanic isolation within the safety extra-low voltage circuit (SELV)
- 2) Optional product feature
- 3) Depends on the CPU type
- 4) Depends on the selected device configuration

17.1.3 Position of the ports on the motherboard

Interfaces

The motherboard of the device features the following interfaces:

- Interfaces for the connection of external devices
- Interfaces for internal components (drives, bus boards etc.)

The figure below shows the location of the internal and external interfaces on the motherboard.

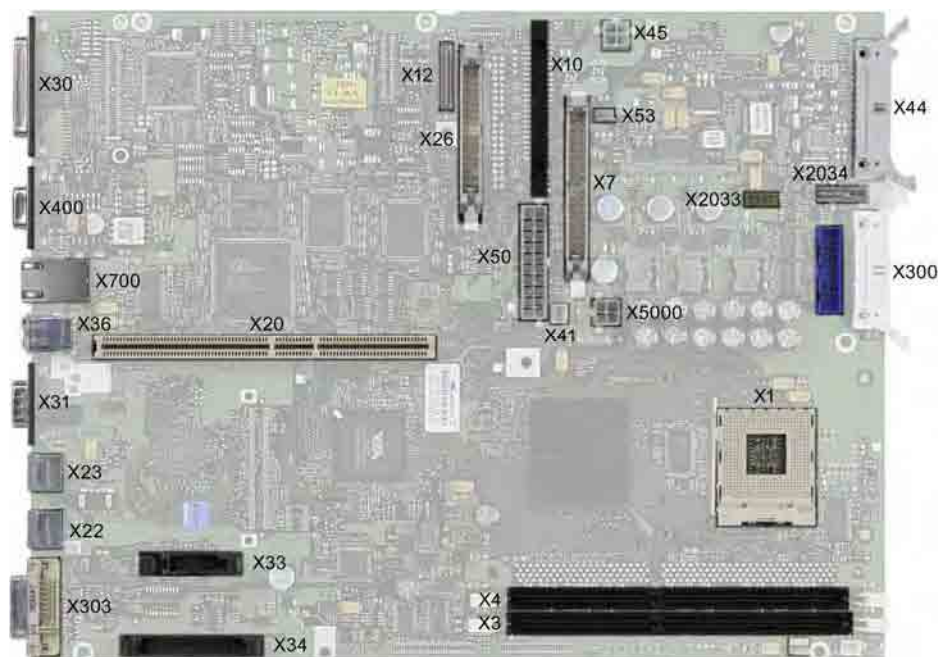

17.1.4 External interfaces

Interface	Position	Connector	Description
COM1	External	X30	25-pin socket, V.24/V.28
COM2	External	X31	9-pin, standard connector
LPT1	External	-	25-pin, standard socket
PS/2 mouse	External	X22	6-pin, miniature DIN socket
PS/2 keyboard	External	X23	6-pin, miniature DIN socket
USB 2.0		X36	X36 first (X36 below) and second USB channel, (X36 above)
PROFIBUS/MPI	External	X400	9-pin, standard socket, galvanically isolated interface
Ethernet	External	X700	RJ45
DVI	External	X303	26-pin socket

Serial interface COM 1, X30

The serial interface (COM 1) on the device has the following pinout:

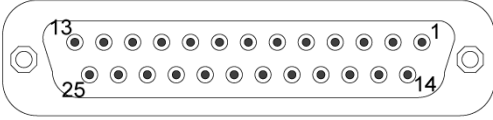
Serial interface COM 1 (socket)			
			
PinNo.	Abbreviation	Meaning	Input/Output
1	–	Shielding	–
2	TxD (D1)	Serial transmit data	Output
3	RxD (D2)	Serial receive data	Input
4	RTS (S2)	Request to send	Output
5	CTS (M2)	Clear to send	Input
6	DSR (M1)	Ready for operation	Input
7	GND (E2)	System ground (reference potential)	–
8	DCD (M5)	Data carrier detect	Input
9	–	–	–
10–17	–	Not assigned	–
18	–	–	–
19	–	–	–
20	DTR (S1)	Data terminal ready	Output
21	–	–	–
22	RI (M3)	Incoming call	Input
23–25	–	Not assigned	–

COM 2 serial interface (V24/Mouse), X31

The serial interface (COM 2) has the following pinout:

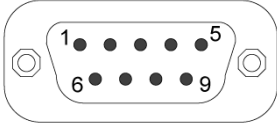
COM 2 serial interface (V24/Mouse)			
			
PinNo.	Abbreviation	Meaning	Input/Output
1	DCD (M5)	Receiving signal level carrier	Input
2	RxD (D2)	Received data	Input
3	TxD (D1)	Transmitted data	Output
4	DTR (S1)	Data terminal ready	Output
5	GND (E2)	System ground (reference potential)	–
6	DSR (M1)	Ready for operation	Input
7	RTS (S2)	Request to send	Output
8	CTS (M2)	Clear to send	Input
9	RI (M3)	Incoming call	Input

LPT1 parallel interface, X134

The parallel interface (LPT 1) has the following pinout:

Parallel interface LPT1			
PinNo.	Abbreviation	Meaning	Input/Output
1	/ Strobe (CLK)	Data message	Output (open collector)
2	Data - Bit 0	Data channel 0	Output (TTL level)
3	Data - Bit 1	Data channel 1	Output (TTL level)
4	Data - Bit 2	Data channel 2	Output (TTL level)
5	Data - Bit 3	Data channel 3	Output (TTL level)
6	Data - Bit 4	Data channel 4	Output (TTL level)
7	Data - Bit 5	Data channel 5	Output (TTL level)
8	Data - Bit 6	Data channel 6	Output (TTL level)
9	Data - Bit 7	Data channel 7	Output (TTL level)
10	/ACK	Data acknowledge	Input (4.7 kO pull-up)
11	BUSY	Not ready	Input (4.7 kO pull-up)
12	PE (PAPER END)	Paper end	Input (4.7 kO pull-up)
13	SELECT	Device selection	Input (4.7 kO pull-up)
14	/ AUTO FEED	Automatically new line	Output (open collector)
15	/ ERROR	Device error	Input (4.7 kO pull-up)
16	/ INIT	Reset / Initialization	Output (open collector)
17	/ SELECT IN	Printer selection	Output (open collector)
18 – 25	GND	Ground	–

PS/2 mouse interface, X22

Pin assignment of the interface:

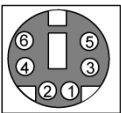
PS/2	Pin No.	Abbreviation	Meaning	Input/Output
 <p>View onto the socket</p>	1	DAT	Data channel, mouse	Input/output
	2	–	Not assigned	–
	3	GND	Ground	–
	4	P5VFK	+ 5 V (fused)	Output
	5	CLK	Clock channel, mouse	Input/output
	6	–	Not assigned	–

PS/2 keyboard interface, X23

Pin assignment of the interface:

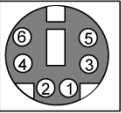
PS/2	Pin No.	Abbreviation	Meaning	Input/Output
 <p>View onto the socket</p>	1	DAT	Data channel, keyboard	Input/output
	2	–	Not assigned	–
	3	GND	Ground	–
	4	P5VFK	+ 5 V (fused)	Output
	5	CLK	Clock channel, keyboard	Input/output
	6	–	Not assigned	–

USB interfaces, X36

The Universal Serial Bus interfaces have the following pinout:

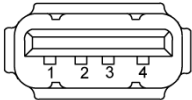
USB interface			
			
Pin No.	Abbreviation	Meaning	Input/Output
1	VCC	+ 5 V (fused)	Output
2	– Data	Data channel	Input/Output
3	+ Data	Data channel	Input/Output
4	GND	Ground	–

The connectors are of type A.

The interface is rated as a high current USB (500mA).

PROFIBUS/MPI interface, X400

The PROFIBUS/MPI socket has the following pinout:

PROFIBUS/MPI interface ¹⁾			
PinNo.	Abbreviation	Meaning	Input/Output
1	–	Not assigned	–
2	–	Not assigned	–
3	LTG_B	Signal line B of MPI module	Input/output
4	RTS_AS	RTSAS, control signal for received data stream. The signal is "1" active when the directly connected PLC is sending.	Input
5	M5EXT	M5EXT return line (GND) of the 5 V power supply. The current load caused by an external consumer connected between P5EXT and M5EXT must not exceed the maximum of 90 mA.	Output
6	P5 EXT	P5EXT power supply (+5 V) of the 5 V power supply. The current load caused by an external consumer connected between P5EXT and M5EXT must not exceed the maximum of 90 mA.	Output
7	–	Not assigned	–
8	LTG_A	Signal line A of MPI module	Input/output
9	RTS_PG	RTS output signal of the MPI module. The control signal is "1" when the PG is sending.	Output
Shielding		on connector casing	

¹⁾ Optional product feature

Ethernet RJ45 connection, X700

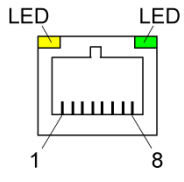
Ethernet RJ45 connection			
 <p>The diagram shows a top-down view of an RJ45 connector. It has eight pins numbered 1 to 8. Pin 1 is on the left and pin 8 is on the right. Above pin 1 is a yellow LED, and above pin 8 is a green LED. The connector is labeled 'LED' for both LEDs.</p>			
PinNo.	Abbreviation	Meaning	Input/Output
1	TD+	Transmitted data	Output
2	TD-	Transmitted data	Output
3	RD+	Received data	Input
4, 5 ¹⁾	SYMR	Internal 75 Ohm terminating resistor	–
6	RD-	Received data	Input
7, 8 ¹⁾	SYMT	Internal 75 Ohm terminating resistor	–
S		Shielding	–
	Yellow LED	Connection	–
	Green LED	Activity	–

¹⁾ is not necessary for data transfer

DVI interface, X303

The DVI socket has the following pinout:

DVI interface			
PinNo.	Abbreviation	Meaning	Input/Output
S	GND	Ground	–
S1	GND	Ground	–
C1	R	Red	Output
C2	G	Green	Output
C3	B	Blue	Output
C4	HSYNC	Horizontal synchronizing pulse	Output
C5	GND	Ground	–
CSA	GND	Ground	–
1	TX2N	TDMS data 2-	Output
2	TX2P	TDMS data 2+	Output
3	GND	Ground	–
4	NC	Not assigned	–
5	NC	Not assigned	–
6	DDC CLK	DDC clock	Input/Output
7	DDC CLK	DDC data	Input/Output
8	VSYNC	Vertical synchronizing pulse	Output
9	TX1N	TDMS data 1-	Output
10	TX1P	TDMS data 1+	Output
11	GND	Ground	–
12	NC	Not assigned	–
13	NC	Not assigned	–
14	+5 V	+5 V	Output
15	GND	Ground	–
16	MONDET	Hotplug detect	Input
17	TX0N	TDMS data 0-	Output
18	TX0P	TDMS data 0+	Output
19	GND	Ground	–
20	NC	Not assigned	–
21	NC	Not assigned	–
22	GND	Ground	–
23	TXCP	TDMS clock +	Output
24	TXCN	TDMS clock -	Output

17.1.5 Front interfaces

Overview

Interface	Position	Connector	Description
Display (LVDS)	Internal	X300	Connection of LCD displays with LVDS interface (channel 1)
Display (LVDS)	Internal	X310	Connection of LCD displays with LVDS interface (channel 2)
I/O front	Internal	X44	Interface for I/O front
COM2	Internal	X33	Internal COM2 interface
USB	Internal	X2033	Internal USB 2.0 interface (USB channel 5)

Display interfaces

TFT displays with an LVDS interface can be connected to this interface. You may connect 18-bit displays with a resolution up to 1024x768 pixels on X300 only (single-channel LVDS), and of 1280 x 1024 pixels on X300 and X301 (dual-channel LVDS). X301 is also connected to a +12VF at max. 4.2. A power supply for backlight inverters for 17" / dual-channel LVDS displays. The permitted display clock rate is 20MHz to 66MHz. The display is selected automatically according to the coding of the display select inputs.

The display power supply voltages (3.3V and 5V) are switched via the graphic controller, independent of the requirements of the connected display units. The maximum cable length is 50 cm at a transmission rate of 455 MHz. Make allowances for the special channel features of differential line pairs with LVDS specifications.

Display interface (1st LVDS channel), X300

Pin No.	Abbreviation	Meaning	Input/Output
1	P5V_D_fused	+5V (fused) display VCC	Output
2	P5V_D_fused	+5V (fused) display VCC	Output
3	RXIN0-	LVDS output signal bit 0 (-)	Output
4	RXIN0+	LVDS output signal bit 0 (+)	Output
5	P3V3_D_fused	+3.3V (fused) display VCC	Output
6	P3V3_D_fused	+3.3V (fused) display VCC	Output
7	RXIN1-	LVDS output signal bit 1 (-)	Output
8	RXIN1+	LVDS output signal bit 1 (+)	Output
9	GND	Ground	-
10	GND	Ground	-
11	RXIN2-	LVDS output signal bit 2 (-)	Output
12	RXIN2+	LVDS output signal bit 2 (+)	Output
13	GND	Ground	-
14	GND	Ground	-
15	RXCLKIN-	LVDS clock signal (-)	Output
16	RXCLKIN+	LVDS clock signal (+)	Output
17	GND	Ground	-
18	GND	Ground	-
19	NC	Not assigned	-
20	NC	Not assigned	-

Display interface (2nd LVDS channel), X310

Pin No.	Abbreviation	Meaning	Input/Output
1	GND	Ground	-
2	GND	Ground	-
3	RXIN10-	LVDS input signal bit 0 (-)	Output
4	RXIN10+	LVDS input signal bit 0 (+)	Output
5	GND	Ground	Output
6	GND	Ground	Output
7	RXIN11-	LVDS input signal bit 1 (-)	Output
8	RXIN11+	LVDS input signal bit 1 (+)	Output
9	GND	Ground	-
10	GND	Ground	-
11	RXIN12-	LVDS input signal bit 2 (-)	Output
12	RXIN12+	LVDS input signal bit 2 (+)	Output
13	GND	Ground	-
14	GND	Ground	-
15	RXCLKIN1-	LVDS clock signal (-)	Output
16	RXCLKIN1+	LVDS clock signal (+)	Output
17	GND	Ground	-
18	P12VF	+12V fused	Output
19	P12VF	+12V fused	Output
20	P12VF	+12V fused	Output

I/O front interface for operator panels, X44

This interface carries all signals required for the connection of operator panels in addition to the display and USB interface. The maximum cable length is 50 cm at a USB data rate of 12 Mbps.

Pin No.	Abbreviation	Meaning	Input/Output
1	GND	Ground	-
2	P12V	Inverter voltage supply	Output
3	BL_ON	Backlight ON (5 V = ON)	Output
4	P5V_fused	+5 V (fused)	Output
5	GND	Ground	-
6	P3V3_fused	+3.3 V VCC (fused)	Output
7	K_CLK	Keyboard clock channel	Output
8	K_DATA	Keyboard data channel	Input/Output
9	M_CLK	Mouse clock channel	Output
10	K_DATA	Mouse data channel	Input/Output
11	P5V_fused	+5 V (fused)	Output
12	USB_D1M	USB data channel 1	Input/Output
13	USB_D1P	USB data+, channel 1	Input/Output
14	GND	Ground	-
15	LCD_SEL0	Display type - Select signal 0	Input
16	LCD_SEL1	Display type - Select signal 1	Input
17	LCD_SEL2	Display type - Select signal 2	Input
18	LCD_SEL3	Display type - Select signal 3	Input
19	RESET_N	Reset signal (active low)	Input
20	Power button	Power button function front	Input
21	HD_LED	HD LED, anode with 1 kW in series on the motherboard	Output
22	DP_LED	MPI/DP LED, anode via 1 kohm in series on the motherboard	Output
23	Ethernet_LED	Ethernet LED, anode with 1 kW in series on the motherboard	Output
24	TEMP_ERR	Temperature error LED, anode with 1 kW in series on the motherboard	Output
25	RUN_R	Watchdog error LED, anode with 1 kW in series on the motherboard	Output
26	RUN_G	Watchdog OK LED, anode with 1 kW in series on the motherboard	Output

Assignment of the display to the display select pins

The display select inputs are used to configure one of 15 possible displays automatically. The display select inputs are equipped with pull-up resistors, i.e., these inputs have a high signal if they are not connected. The input must be connected to GND if a low signal is to be generated.

Pin No.	LCD_SEL3	LCD_SEL2	LCD_SEL1	LCD_SEL0	Display type
0	low	low	low	low	reserved
1	low	low	low	high	1280x1024 (SXGA), TFT, 2 x 18-bit, LVDS channel 1 and 2
2	low	low	high	low	DVI LCD 640 x 480
3	low	low	high	high	DVI LCD 800 x 600
4	low	high	low	low	640 x 480 (VGA), TFT, 18 bits, LVDS channel 1
5	low	high	low	high	reserved
6	low	high	high	low	1024 x 768 (XGA), TFT, 18 bits, LVDS channel 1
7	low	high	high	high	800 x 600 (SVGA), TFT, 18 bits, LVDS channel 1
8	high	low	low	low	reserved
9	high	low	low	high	reserved
10	high	low	high	low	reserved
11	high	low	high	high	reserved
12	high	high	low	low	Reserved 1024 x 768 (XGA), TFT, 2 x 18-bit, LVDS channel 1 and 2
13	high	high	low	high	DVI LCD 1024 x 768
14	high	high	high	low	DVI LCD 1280 x 1024
15	high	high	high	high	No LVDS display or DVI LCD with automatic DDC ID

17.1.6 Internal interfaces

Pin assignment of the internal interfaces

Interface	Position	Connector	Description
Memory	Internal	X3, X4	2 DIMM sockets, 64-Bit
Processor	Internal	X1	Socket for FCPGA mobile processor
Bus expansion	Internal	X20	Socket for bus expansion, assigned with ISA and PCI bus signals
Power supply	Internal	X50, X5000	20-pin power supply connector ATX 12 V expansion
Floppy	Internal	X26	One drive is possible (82078 compatible) 360 K, 720 K, 1.2 MB, 1.44 MB 3F0h–3F7h, 370h–377h, switched IRQ 6, edge triggered 34-pin socket for standard FD drive
3.5" hard disk drive	Internal	X7	170h–177h, 1F0h–1F7h, switchable IRQ 14, IRQ 15, edge triggered 40-pin, 2.54mm male connector (3.5" HD, primary), up to two drives can be operated
CD-ROM, (back-packed)	Internal	X10	170h–177h, 1F0h–1F7h, switchable IRQ14, IRQ15, edge triggered 44-pin, 2 mm male connector
CD-ROM, integrated	Internal	X12	170h–177h, 1F0h–1F7h, switchable IRQ14, IRQ15, edge triggered 1 x 41-pin (Hirose DF9-41, CD-ROM, Master)
PS circuit for CPU fan	Internal	X41	Power supply for CPU fan, 3-pin male connector
PS connection for equipment fan	Internal	X42	Power supply for equipment fan, 3-pin male connector
Backup battery	Internal	X49	Power supply for backup battery, 2-pin male connector
Power supply connection for 19" front components with 12 V DC power supply	Internal	X45	Additional power supply connector for 19" fronts

Interface	Position	Connector	Description
On / Off switch	Internal	X53	Switches off the power supply on the secondary side, the AUX voltage is not switched off.
LVDS channel 1	Internal	X300	LVDS display interface for 12 to 19" fronts
LVDS channel 2	Internal	X310	Expansion of the LVDS display interface X300 for dual-channel LVDS displays (resolution 1280 x 1024)
I/O interface for front components	Internal	X44	
USB interface	Internal	X2033	
USB interface for front components	Internal	X2034	USB interface (front USB channels 3 and 5)

Connection for optical drive, X12

Pin No.	Abbreviation	Meaning	Input/Output
1	Reserved	Reserved	-
2	Reserved	Reserved	-
3	Reserved	Reserved	-
4	GND	Ground	-
5	Reset	Reset signal	Input/Output
6	D8	Data signal D8	Input/Output
7	D7	Data signal D7	Input/Output
8	D9	Data signal D9	Input/Output
9	D6	Data signal D6	Input/Output
10	D10	Data signal D10	Input/Output
11	D5	Data signal D5	Input/Output
12	D11	Data signal D11	Input/Output
13	D4	Data signal D4	Input/Output
14	D12	Data signal D12	Input/Output
15	D3	Data signal D3	Input/Output
16	D13	Data signal D13	Input/Output
17	D2	Data signal D2	Input/Output
18	D14	Data signal D14	Input/Output
19	D1	Data signal D1	Input/Output
20	D15	Data signal D15	Input/Output
21	D0	Data signal D0	Input/Output
22	DREQ	DMA request	Input
23	GND	Ground	-
24	IOR_N	Read signal	Output
25	IOW_N	Write signal	Output
26	GND	Ground	-
27	IORDY	Ready signal	Input
28	DACK_N	DMA acknowledgment	Output
29	IRQ15	Interrupt signal	Input
30	AD_1	Address 1	Output
31	AD_0	Address line 0	Output
32	AD_2	Address line 2	Output
33	CS_N	Chip select signal	Output
34	HDACT_N	Activity	Input
35	CS1_N	Chip select 1	-
36	CSEL	Chip select signal	-
37	GND	Ground	-
38	P5V	+5 V voltage supply	Output
39	P5V	+5 V voltage supply	Output
40	P5V	+5 V voltage supply	Output
41	P5V	+5 V voltage supply	Output

Interface to floppy disk drive, X26

This interface is designed for connecting a standard floppy drive. The maximum length of the data cable should not exceed 40 cm.

Pin No.	Abbreviation	Meaning	Input/Output
1	GND	Ground	-
2	DENSEL	High density disk selection	Output
3	GND	Ground	-
4	-	Not assigned	-
5	GND	Ground	-
6	DRAME0	Data rate signal	Output
7	GND	Ground	-
8	INDEX_N	Index hole recognition	Input
9	GND	Ground	-
10	MOT_N0	Activate motor 0	Output
11	GND	Ground	-
12	DS_N1	Drive 1 selection	-
13	GND	Ground	-
14	DS_N0	Drive 0 selection	-
15	GND	Ground	-
16	MOT_N0	Activate motor 1	Output
17	GND	Ground	-
18	DIR_SL_N	Step motor direction	Output
19	GND	Ground	-
20	STEP_N	Step motor pulse	-
21	GND	Ground	-
22	WR_DAT_N	Write data signal	Output
23	GND	Ground	-
24	WR_GAT_N	Enable data signal	Output
25	GND	Ground	-
26	TRACK_N0	Track 0 signal	Input
27	GND	Ground	-
28	WR_PRT_N	Write protection signal	Input
29	GND	Ground	-
30	RD_DAT_N	Read data signal	Input
31	GND	Ground	-
32	SIDE_1_N	Page selection	Output
33	MED_ID1	High density disk recognition	Input
34	DCHG_N	Disk change display	Input

Pinout of the CPU fan power supply, X41

Pin No.	Abbreviation	Meaning	Input/Output
1	GND	Ground	-
2	+12 V	Switched power supply	Output
3	CPU FAN_CLK	Clock signal	Input

Pinout of the main fan power supply, X42

Pin No.	Abbreviation	Meaning	Input/Output
1	GND	Ground	-
2	+12 V	Switched power supply	Output
3	PG1 FAN_CLK	Clock signal	Input

Additional power supply connector (12V) for devices with 19" front, X45.

Pin No.	Abbreviation	Meaning	Input/Output
1	GND	Ground	-
2	GND	Ground	-
3	+12 V	12 V power supply	Input
4	-12 V	12 V power supply	Input

Connector for back-up battery, X49

A battery for buffering the CMOS RAM is connected to this connector. This is a 3.6 V Lithium battery with a capacity of 750 mAh.

Pin No.	Abbreviation	Meaning	Input/Output
1	+	Plus pole	Input
2	-	Minus pole	-

Connection for On / Off switch connector, X53

Pin No.	Abbreviation	Meaning	Input/Output
1	Power On	On signal	Input
2	GND	Ground	-

Pinout of the internal USB interface connector, X2033

Pin No.	Abbreviation	Meaning
1	VCC 3.3V	+3.3V, fused
2	VCC 5V	+ 5 V, fused
3	USB3	USB3_M
4	USB5	USB5_M
5	USB3	USB3_P
6	USB5	USB5_P
7	GND	Ground
8	GND	Ground
9	GND	Ground
10	GND	Ground

Pinout of the USB 2.0 interface, X2034

Pin No.	Abbreviation	Meaning
1	VCC	+ 5 V, fused
2	USB5	USB5_M
3	USB5	USB5_P
4	GND	Ground
S1	S	Shielding
S2	S1	Shielding

Note

For detailed information on the pin assignments of the interfaces, please contact Customer Support or the Repair Center.

17.2 Bus board

17.2.1 Layout and principle of operation

The bus board is designed as a link between the motherboard and the expansion modules. It is mounted with two screws.

The bus board has two PCI expansion slots (2x long), two long shared ISA/PCI and one long ISA slot. It can host expansion modules conforming to ISA specification (Rev. 3.1) and PCI specification (Rev. 2.0 for 5 V and 3.3 V modules). All PCI slots are master-capable. The expansion modules are supplied with power via the bus board to motherboard connection.

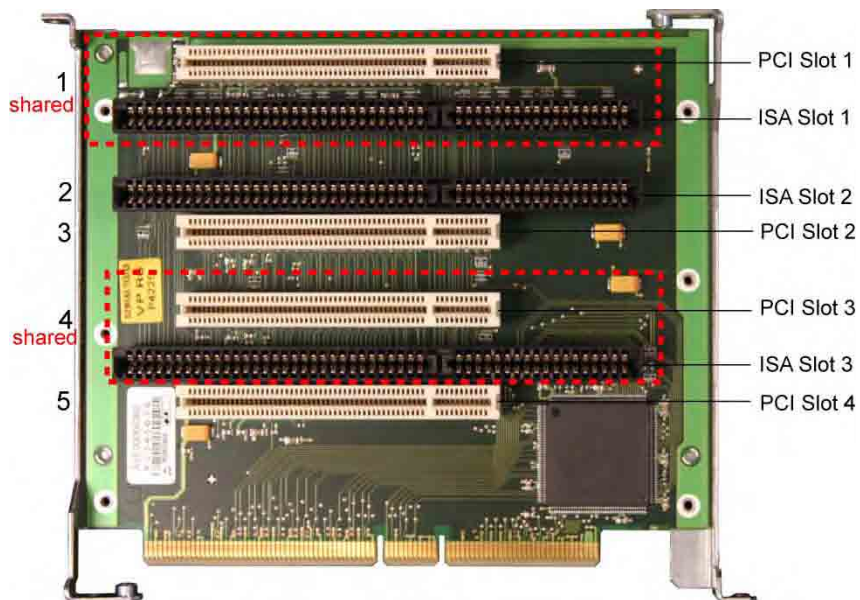

Figure 17-1 Bus board

17.2.2 Assignment of the PCI IRQ channels to the PCI slots

Assignment of the PCI IRQ channels to the PCI slots

Box PC 840 V2	PCI modules interrupt assignment (PCI IRQ) in:			
Module interrupt (Pin No.)	Slot 1	Slot 2	Slot 3	Slot 4
INT – A (A6)	channel 1	channel 2	channel 3	channel 4
INT – B (B7)	channel 2	channel 3	channel 4	channel 1
INT – C (A7)	channel 3	channel 4	channel 1	channel 2
INT – D (B8)	channel 4	channel 1	channel 2	channel 3

Highlighted entries refer to master interrupts of the slot module

17.2.3 Exclusive PCI hardware interrupt

Applications demanding a high-performance interrupt require a high-speed hardware interrupt reaction. The PCI hardware interrupt should be used only by one resource in order to ensure high-speed reaction of the hardware. This can be forced by appropriate setting in the system BIOS.

Setting up a reserved interrupt on the device

A reserved interrupt can only be set and used for PCI slots 2 and 4. Further reserved interrupts for use on the slots are not available.

A reserved interrupt cannot be used on any of the PCI slots in the basic configuration. In order to set up a reserved interrupt, you first need to disable the functions on the motherboard¹⁾. This is possible for PCI slots 2 and 4.

In order to set up a reserved interrupt on PCI slot 2, you need to disable USB Controller B (this is the external USB port at the top) in the BIOS.

In order to set up a reserved interrupt on PCI slot 4, you need to disable USB 2.0 Controller in the BIOS (all USB ports are now operating in USB 1.1 mode) and (if installed in the device) the PROFIBUS.

¹⁾ For information on how to disable motherboard functions, refer to the chapter dealing with the BIOS setup.

Assigning a reserved interrupt in the BIOS Setup

With the factory setting of the system BIOS, the interrupts are automatically assigned to the slots.

Depending on the system configuration, several slots may be assigned the same interrupt. Here we refer to interrupt sharing.

The special feature of the BIOS of the device is that interrupts can be set selectively and assigned to the interrupt channels of the slots. Here we refer to a reserved interrupt.

Specific interrupts can be assigned to slots in the **Advanced** menu of the BIOS setup.

To do so:

To enable the use of a reserved interrupt at **PCI slot 2**, assign **PCI IRQ Line 2** the required free interrupt, and **all other** PCI interrupt channels (channels 1, 3, 4) **another** interrupt.

To enable the use of a reserved interrupt at **PCI slot 4**, assign **PCI IRQ Line 4** the required free interrupt, and **all other** PCI interrupt channels (channels 1, 2, 3) **another** interrupt.

To do this, open the **Advanced** menu of the BIOS setup and then **PCI Configuration**. In this menu you can assign the specific **PCI IRQ channels** to the respective interrupts.

You cannot assign interrupts that are already used by the system.

If you assign an interrupt which is already in use by the system or is reserved, the system marks it with a yellow star.

→ May not be used.

Interrupts not reserved by the system can be assigned twice.

17.2.4 ISA slot pin assignment

Pin No.	Abbreviation	Type*	Pin No.	Abbreviation	Type
A1	IOCHCK#	I	B1	0V	GND
A2	SD 07	I/O	B2	RESET DRV	O
A3	SD 06	I/O	B3	+ 5V	VCC
A4	SD 05	I/O	B4	IRQ 9	I
A5	SD 04	I/O	B5	- 5V	VCC
A6	SD 03	I/O	B6	Reserved	I
A7	SD 02	I/O	B7	- 12V	VCC
A8	SD 01	I/O	B8	Reserved	I
A9	SD 00	I/O	B9	+ 12V	VCC
A10	IOCHRDY	I	B10	0V	GND
O11	AEN	O	B11	SMEMW#	O
A12	SA 19	I/O	B12	SMEMR#	O
A13	SA 18	I/O	B13	IOW#	I/O
A14	SA 17	I/O	B14	IOR#	I/O
A15	SA 16	I/O	B15	DACK3#	O
A16	SA 15	I/O	B16	DRQ 3	I
A17	SA 14	I/O	B17	DACK1#	O
A18	SA 13	I/O	B18	DRQ 1	I
A19	SA 12	I/O	B19	REFRESH#	I/O
A20	SA 11	I/O	B20	CLK	O
O21	SA 10	I/O	B21	IRQ 7	I
A22	SA 09	I/O	B22	Reserved	I
A23	SA 08	I/O	B23	IRQ 5	I
A24	SA 07	I/O	B24	IRQ 4	I
A25	SA 06	I/O	B25	IRQ 3	I
A26	SA 05	I/O	B26	Reserved	O
A27	SA 04	I/O	B27	TC	O
A28	SA 03	I/O	B28	BALE	O
A29	SA 02	I/O	B29	+ 5V	VCC
A30	SA 01	I/O	B30	OSC	O
A31	SA 00	I/O	B31	0 V	GND

*) I/O determines the direction of the signals for the CPU module.

low active

Pin No.	Abbreviation	Type*	Pin No.	Abbreviation	Type
C1	-SBHE	O	D1	-MEMCS16	I
C2	LA 23	I/O	D2	-IOCS16	I
C3	LA 22	I/O	D3	IRQ 10	I
C4	LA 21	I/O	D4	IRQ 11	I
C5	LA 20	I/O	D5	IRQ 12	I
C6	LA 19	I/O	D6	IRQ 13	I
C7	LA 18	I/O	D7	IRQ 14	I
C8	LA 17	I/O	D8	-DACK0	O
C9	-MEMR	I/O	D9	DRQ 0	I
C10	-MEMW	I/O	D10	-DACK5	O
C11	SD 08	I/O	D11	DRQ 5	I
C12	SD 09	I/O	D12	-DACK6	O
C13	SD 10	I/O	D13	DRQ 6	I
C14	SD 11	I/O	D14	-DACK7	O
C15	SD 12	I/O	D15	DRQ 7	I
C16	SD 13	I/O	D16	+ 5V	VCC
C17	SD 14	I/O	D17	-MASTER	I
C18	SD 15	I/O	D18	0 V	GND

Under normal conditions, the signals -SBHE, LA17 - LA23, -MEMR and MEMW are operated as outputs (sending from the CPU). Only CPU modules which are suitable for use as a master CPU for system bus access send and receive these signals. A minus sign "-" in front of the signal name shows that the signal is LOW active.

17.3 Operating system licenses

Description:

The supplied and installed Windows operating systems of the SIMATIC PCs are full Windows versions without any function restrictions. The additional wording "For Embedded Systems" on the accompanying operating system Recovery CD describes the contractual conditions under which Siemens AG acquires the licenses from Microsoft. The Microsoft Windows 2000 Professional MUI and Microsoft Windows XP Professional MUI operating systems supplied to Siemens AG under the license "Microsoft Operating Systems for Embedded Systems" for use with SIMATIC PG/PC products are equivalent to the relevant version from the desktop/office sales channel.

This provides numerous advantages for customers in the industrial environment over the OEM licenses marketed in the office environment:

- No license for Windows XP Professional is required from Microsoft by the customer (important when components are replaced during servicing)
- In addition to the operating system CD (Recovery CD), the contract permits a Restore DVD to be supplied (image of the operating system as delivered - including all relevant drivers and software)
- The license permits images created by a customer to be transferred to any number of SIMATIC PCs that are fitted with the relevant COA (Certificate of Authenticity) labels "for Embedded Systems"
- The COA label on the device is the only license verification required. An additional license agreement is not necessary

The license conditions in the operating system pack contain a reference to "restricted functionality". This note only refers to the application scope of this license and is defined for industrial applications, such as industrial controls, programming devices, information terminals, instruments, displays, Web panels, etc. These devices must not be primarily intended for use in domestic or office environments.

The licenses "for Embedded Systems" must not be confused with the Windows embedded operating systems, such as Windows XPe (Windows XP embedded). These may also contain functional limitations that have been implemented in favor of reduced memory allocation for image generation.

17.4 Cables

SIMATIC S7 cable for MPI/DP

The 6ES7901-0BF00-0AA0 cable is used to connect the device to a SIMATIC S7 automation device. Refer to the "Integration" section for more information.

17.5 System resources

17.5.1 Currently allocated system resources

All system resources (hardware addresses, memory configuration, interrupt assignment, DMA channels) are assigned dynamically by the Windows OS, depending on the hardware configuration, drivers, and connected peripheral devices. You can view the current configuration of system resources or possible conflicts with the following operating systems:

Windows 2000 Professional/ XP Professional	Start > Run : In the Open dialog, enter <i>msinfo32</i> and confirm with OK
--	---

17.5.2 System resources used by the BIOS/DOS

The following table describes the system resources for the factory state of the device.

17.5.2.1 I/O address allocation

I/O address (hex)		Size (bytes)	Description of the basic function	Possible alternative function
from	to			
0000	000F	16	DMA controller	
0010	001F	16	Motherboard resources	
0020	0021	2	Programmable interrupt controller	
0022	003F	30	Motherboard resources	
0040	0043	4	System timer	
0044	005F	28	Motherboard resources	
0060	0060	1	Keyboard controller	
0061	0061	1	System loudspeaker	
0062	0063	2	Motherboard resources	
0064	0064	1	Keyboard controller	
0067	006F	9	Motherboard resources	
0070	0075	6	System CMOS/real-time clock	
0076	0080	138	Motherboard resources	
0081	008F	15	DMA controller	
0090	009F	16	Motherboard resources	
00A0	00A1	2	Programmable interrupt controller	
00A2	00BF	30	Motherboard resources	
00C0	00DF	32	DMA controller	
00E0	00EF	16	Motherboard resources	
00F0	00FE	15	Numeric data processor	
0100	016F	112	Unused	
0170	0177	8	Secondary EIDE channel	
0178	01EF	120	Unused	
01F0	01F7	8	Primary EIDE channel	Switchable in Setup, then free
01F8	01FF	116	Unused	
0200	0273	16	Reserved for game port	
0274	0277	4	ISA PNP Read Data Port	
0279	0279	4	ISA PNP Read Data Port	
027C	02E7	108	Unused	

I/O address (hex)		Size (bytes)	Description of the basic function	Possible alternative function
02E8	02EF	8	Reserved	
02F8	02FF	8	COM2	Switchable in Setup, then free
0300	031F	32	Unused	
0320	032F	16	Unused	
0330	033F	16	Unused	
0340	035F	32	Unused	
0360	0367	8	Unused	
0370	0371	2	SOM	
0372	0375	4	Unused	
0376	0376	1	Secondary EIDE channel	
0378	037F	8	LPT 1	Switchable in Setup, then free
0380	03AF	48	Unused	
03B0	03BB	12	S3 Graphics Pro Savage DDR	
03BC	03BF	4	Reserved	
03C0	03DF	16	S3 Graphics Pro Savage DDR	
03E0	03E7	8	Unused	
03E8	03EF	6	Reserved	
03F0	03F5	6	Standard floppy disk controller	
03F6	03F6	1	Primary EIDE channel	
03F7	03F7	1	Standard floppy disk controller	
03F8	03FF	8	COM1	Switchable in Setup, then free
Dynamic area; resources are managed via Plug and Play				
0400	0777	888	Unused	
0778	077F	8	ECP LPT 1	
0780	0CF7	1400	unused	
0CF8	0CFB	4	PCI configuration index	steady
0CFC	0CFF	4	PCI configuration data	steady
0D00	0EFF	512	Unused	
0F00	0F4F	80	Super IO	
0F50	0FFF	176	Unused	
1000	10FF	256	Internal allocation	
1180	11FF	128	Internal allocation	
1800	187F	128	Internal allocation	
8800	8BFF	1023	SATA RAID Controller	
8C00	FEFF	29288	Unused at SATA RAID	
8870	8897	39	Unused	
8898	FEFF	30311	Unused at PATA RAID	
1880	886F	28655	Unused	
FF00	FF0F	16	EIDE bus master register	

17.5.2.2 Interrupt Assignments

Interrupt	Description	Comment
IRQ0	System timer	fixed
IRQ1	Keyboard	fixed
IRQ4	Serial port COM1	2)
IRQ8	Real-time clock (RTC)	fixed
IRQ9	Microsoft ACPI-Compliant System	1)
IRQ13	Numeric processor	fixed
IRQ14	1. IDE channel (primary)	2)
IRQ16	Mobile Intel 915GM/GMS, 910GML Express Chipset Family	1)
IRQ16	Intel® 82801FB/FBM USB Universal Host Controller - 2658	1)
IRQ 16	Intel® 82801FB/FBM USB Universal Host Controller -2659	1)
IRQ 19	Intel® 82801FB Ultra ATA Storage Controllers - 2652	1)
IRQ 20	VIA Rhine III Fast Ethernet Adapter	2)
IRQ 22	Intel® 82801FB/FBM Universal Host Controller - 265A	1)
IRQ 22	Intel® 82801FB/FBM Universal Host Controller -265B	1)
IRQ 22	VIA Rhine III Fast Ethernet Adapter #2	2)
IRQ 23	Intel® 82801FB/FBM USB2 Enhanced Host Controller - 265C	1)

PCI Interrupt Lines	PCI devices interrupt assignment (PCI IRQ)
INT – A	Graphics, USB A (channel 0+1), USB B (channel 2+ 3)
INT – B	Slot 1
INT – C	Slot 2
INT – D	Serial ATA
INT – E	Ethernet 1
INT – F	MPI/DP
INT – G	Ethernet 2, USB C (channel 4+5), USB D (channel 6 + 7)
INT - H	USB 2.0

1) The on-board PCI devices require PCI interrupt channels. These interrupt channels are sharable and plug and play compatible. This means several devices can share the same interrupt. Interrupts are assigned automatically (exception: see section, Exclusive PCI Hardware Interrupt).

2) These functions can be disabled in the Setup This releases allocated resources.

17.5.2.3 Memory address assignments

PCI VGA modules can be operated with an expansion ROM of a size up to 48 K.

Address		Size	Description of the basic function	Possible alternative function
from	to			
0000 0000	0007 FFFF	512K	Conventional system memory	
0008 0000	0009 8FFF	123 K	Conventional system memory extended	
0009 9C00	0009 FFFF	5K	XBDA, extended Bios Data Area	
000A 0000	000A FFFF	64K	VGA graphics refresh memory	
000B 0000	000B 7FFF	32K	Software graphics/text refresh memory	Shared SMM for power management
000B 8000	000B FFFF	32K	VGA graphics/text refresh memory	
000C 0000	000C BFFF	48K	VGA BIOS expansion	
000C C000	000C CFFF	4K	USB	
000C D000	000C DFFF	4K	Optional PXE part,	Always occupied
000C D000	000C FFFF	12K	unused (device driver or ISA hardware)	Can be disabled in SETUP, via EMM High DOS Memory
000D 0000	000D 7FFF	32K	unused (device driver or ISA hardware)	via EMM High DOS Memory
000D 8000	000D FFFF	32K	unused (device or ISA hardware)	via EMM High DOS Memory
000D 0000	000D 97FF	38K	RAID	
000D 0000	000D 93FF	37K	SATA RAID	
000D 9400	000E 97FF	65K	Unused	
000D 9800	000E 97FF	64K	Unused	
000E 0000	000E 3FFF	16K	Legacy USB BIOS extension, cannot be used for ISA cards!	via EMM High DOS Memory
000E 6000	000F FFFF	112K	System BIOS	via EMM High DOS Memory
0010 0000	00EF FFFF	14M	System memory	
00F0 0000	00FF FFFF	16M-15M=1M	System memory or memory hole	
0100 0000	7FFF FFFF	Max. 2 GB - 16 MB	System memory, 512 KB of top of memory are reserved for USB.	via ISA memory setup (memory hole)
7000 0000	FFF7 FFFF		PCI memory address area	Depends on memory configuration
FFF8 0000	FFFF FFFF		Firmware HUB	For PCI expansion cards

17.6 BIOS setup

17.6.1 Overview

BIOS SETUP program

The BIOS SETUP program is stored in the ROM BIOS. Information about the system configuration is stored in the battery-backed RAM of the device.

You can use SETUP to set the hardware configuration (for example, the hard disk type) and define the system properties. You can also use SETUP to set the time-of-day and date.

Changing the device configuration

Your device configuration is preset for working with the software supplied with the unit. You should only change the preset values if you have modified your device in any way, or if a fault occurs when the unit is powered up.

17.6.2 Starting BIOS Setup

Starting BIOS Setup

Start the setup program as follows:

Reset the device (warm or cold restart).

In the figures shown, the default settings differ based on the device versions. With the default setting of your device, the display shown below appears following power-on, **for example**:

```
Phoenix BIOS 4.0 Release 6.0
Copyright 1985 - 2002 Phoenix Technologies Ltd.
All Rights Reserved

SIMATIC Box PC 840 V2 Profibus/MPI
CPU = Intel ® Pentium 4 CPU X.X GHz
639 K System RAM Passed
xxxxxx M Extended RAM Passed (xx depending on memory expansion)
512 K Cache SRAM Passed
ATAPI CD/DVD-ROM : xx CD-ROM
```

On completion of the POST, the BIOS gives you the opportunity of starting the SETUP program. The following message appears on the screen:

```
Press < F2 > to enter SETUP or <ESC> to show boot menu
```

Press the F2 key as long as the BIOS prompt appears on the screen.

17.6.3 BIOS setup menus

The various menus and submenus are listed on the next pages. You can obtain information on the selected SETUP item from the "item-specific help" part of the respective menu.

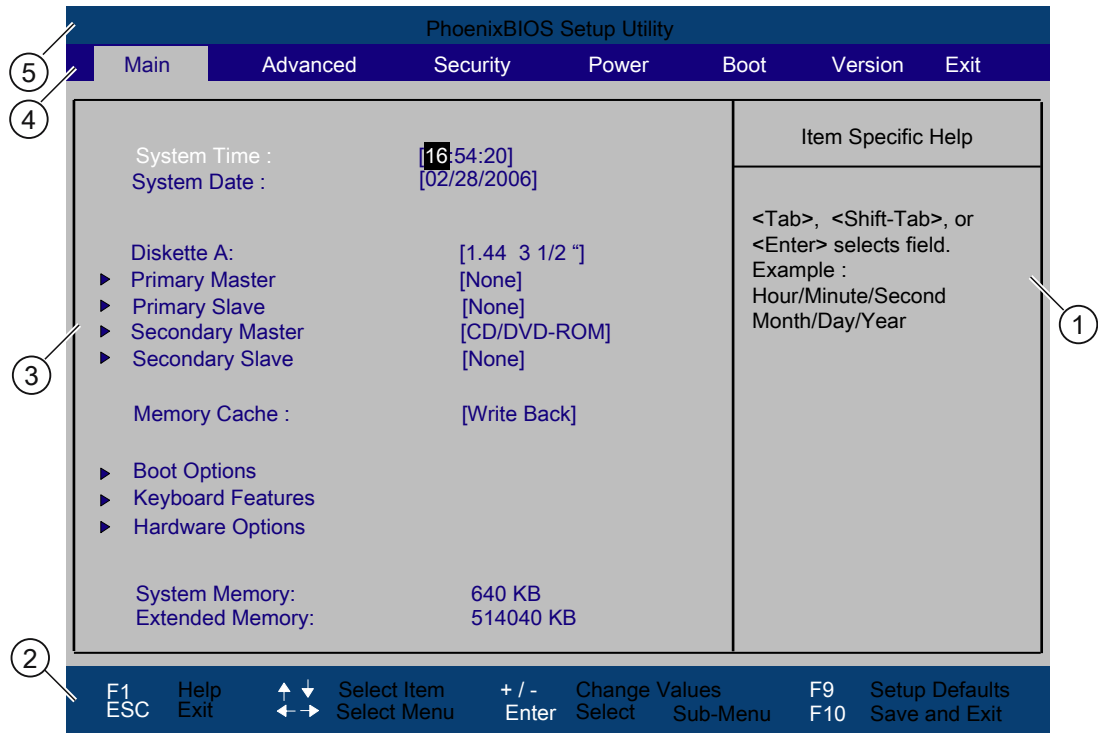

Figure 17-2 SETUP Main Menu (Example)

(1) Help view	(4) Menu line
(2) Input line	(5) Header
(3) Selectable submenu	

Menu layout

The screen is divided into four sections. In the top part (4), you can select the menu forms [Main], [Advanced], [Security], [Power], [Boot Sequence], [Version], [Exit]. In the left of the center section (3) you can select various settings or submenus. Brief help texts appear on the right (1) for the currently selected menu entry. The bottom section contains information for operator input.

The figures below represent examples of specific device configurations. The screen content changes based on the supplied equipment configuration.

Yellow stars to the left of the interface designation (for example, Internal COM 1) indicate a resource conflict between the interfaces managed by the BIOS. In this case you should select the default settings (F9) or eliminate the conflict.

You can move between the menu forms using the cursor keys [←] left and [→] right.

Menu	Meaning
Main	System functions are set here
Advanced	An extended system configuration can be set here
Security	Security functions are set here, for example, a password.
Power	Power-saving functions can be selected here.
Boot	This is where the boot priority is specified.
Version	Information about the programming device (for example, release status) can be found here.
Exit	Used for terminating and saving.

17.6.4 Main menu

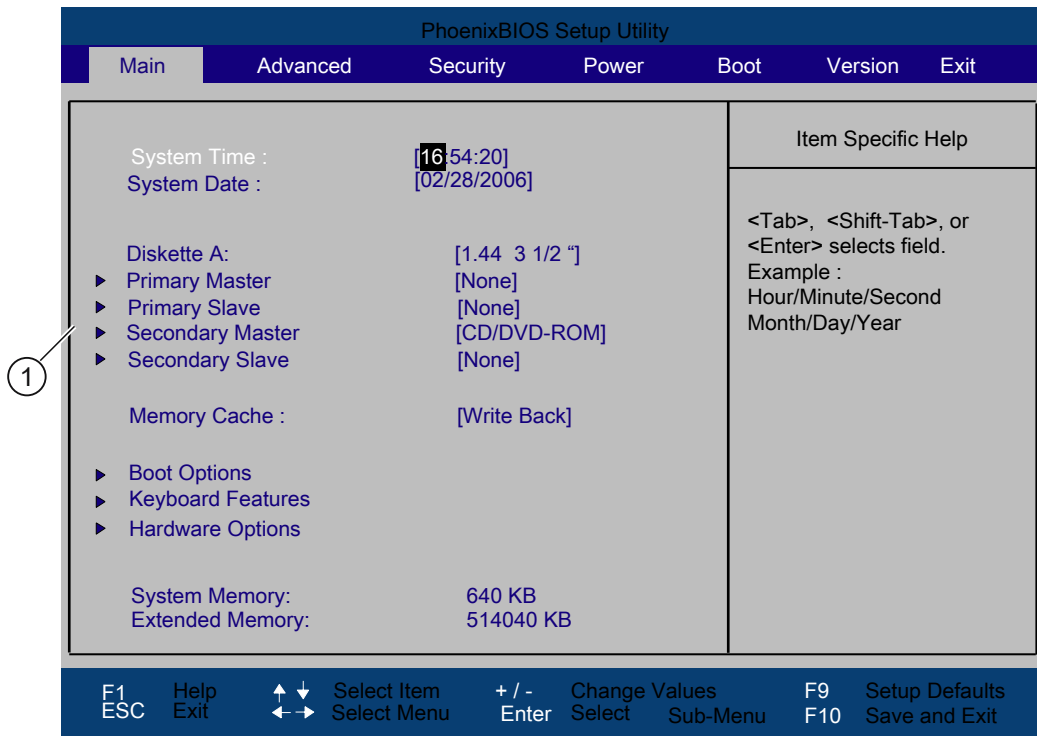

Figure 17-3 SETUP Main Menu (Example)

(1) Selectable submenu

Settings in the main menu

In the main menu, you can move up and down to select the following system configuration boxes by means of the [↑] up and [↓] down cursor keys:

Array	Meaning
System Time	For viewing and setting the current time
System Date	For viewing and setting the current date
Floppy disk A	Type of installed floppy disk drive
Memory Cache	Used for setting the cache options
System memory	for displaying the system memory
Extended Memory	for displaying the memory expansion
by submenus	
Primary master	Type of installed disk drives
Primary Slave	Type of installed disk drives
Secondary Master	Type of installed disk drives
Secondary slave	Type of installed disk drives
Boot options	Used for setting the boot options
Keyboard Features	Used for setting of keyboard interface (for instance, NUM-LOCK, typematic rate)
Hardware Options	Used for setting the hardware options

System time and date

System Time and System Date indicate the current values. Once you have selected the appropriate option, you can use the [+] and [-] keys to modify the time setting

Hour: Minute: Second

and for the date

Month/Day/Year

You can move between the entries in the date and time fields (for example, from hour to minute) using the tab key.

Floppy disk A (Floppy disk drive)

The type of floppy disk drive installed in the PC is set here. The following entries are possible:

[Disabled]	if no disk drive is available.
[1.44 MB, 3 1/2"]	Default setting for an installed disk drive A

Primary master, primary slave, secondary master, secondary slave

The system jumps to the following submenu when you select this type of menu field:

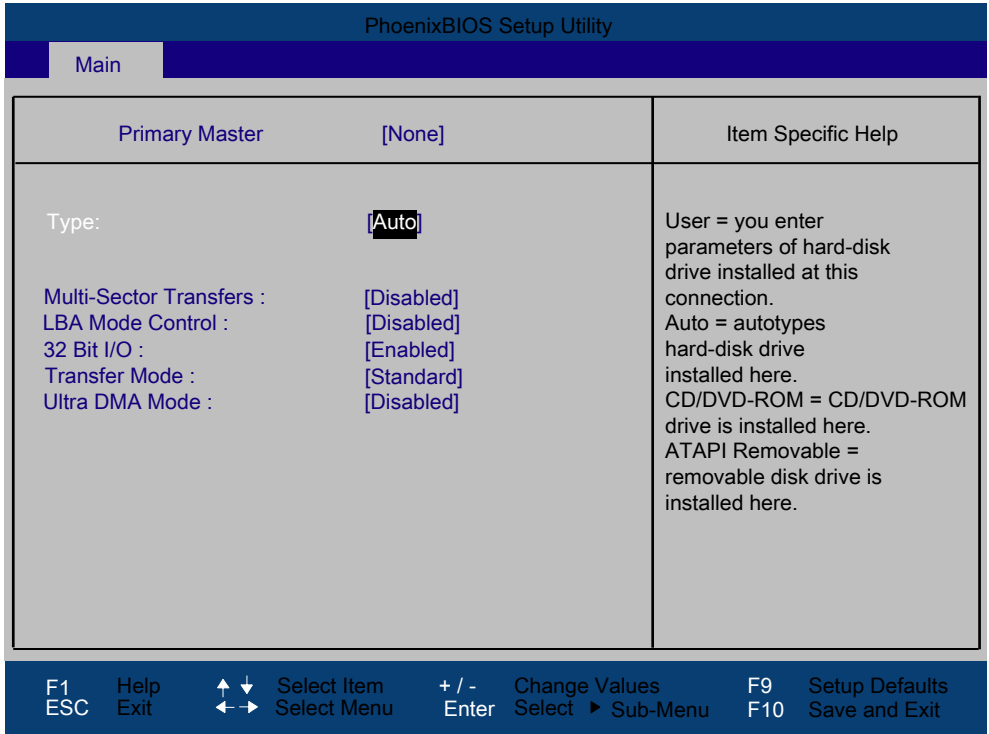

Figure 17-4 Primary Master (Example)

Array	Meaning				
Type	<p>The parameters which you can select here are usually saved on the respective IDE drive. The 'Auto' setting in the 'Type' field means that these values are automatically read from the drive and written to memory (Auto detect).</p> <p>If Type is selected for a drive that cannot be detected, a time-out is triggered within approximately 1 minute and the entries remain unchanged. You should always check that the interfaces for which you select 'Auto' are in fact connected to drives.</p> <p>Select "User" if you want to define the hard disk drive. You also need to configure the other options, for example, Cylinder, Heads, Sectors/Track, or other properties in accordance with the hard disk drive.</p> <p>Select "None" if you have not connected a disk drive. This setting reduces the system waiting time.</p>				
Multi Sector-Transfer	<p>The number of sectors which are transmitted per interrupt are transferred in the option "Multi-Sector Transfers." The value depends on the drive and should be set only to "Auto" in the "Type" field.</p> <p>Disabled 2, 4, 8, 16 sectors</p>				
LBA Mode Control	<p>"Enabled" in the option "LBA Mode Control" (enabled, disabled) means that hard disk capacities greater than 528 MB are supported. The value depends on the drive and should be set only to "Auto" in the "Type" field.</p>				
32-bit I/O	<p>The type of access to the drive is defined in the 32-bit I/O field</p> <table border="1"> <tr> <td>Disabled</td> <td>16-bit access</td> </tr> <tr> <td>Enabled</td> <td>32-bit accesses (default)</td> </tr> </table>	Disabled	16-bit access	Enabled	32-bit accesses (default)
Disabled	16-bit access				
Enabled	32-bit accesses (default)				
Transfer Mode or Ultra DMA Mode	<p>The settings in these fields define the interface data transfer rate. The value depends on the drive and should be set only to "Auto" in the "Type" field.</p> <p>You leave the submenu using the ESC key.</p>				

"Memory cache" field

The following context menu appears when you select the option "Memory cache" in the main menu:

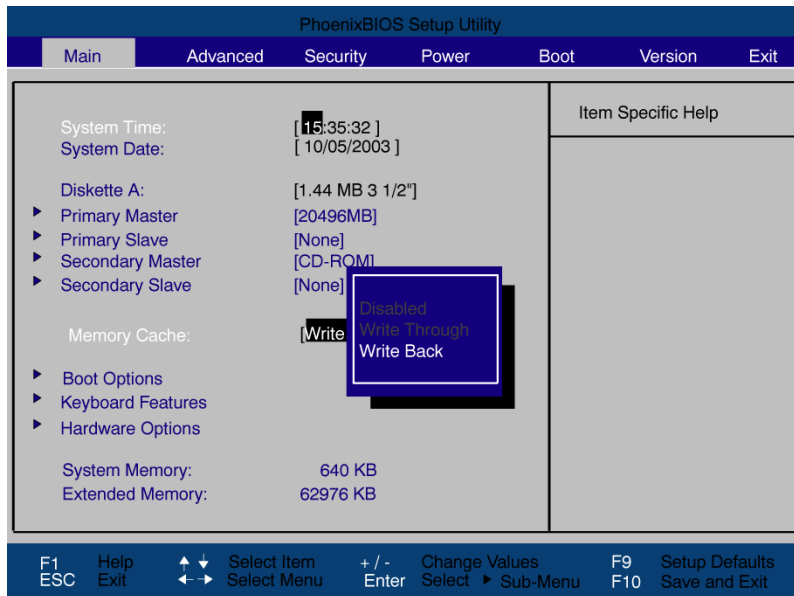

Figure 17-5 "Memory Cache" field

The cache is a high-speed memory buffer between the CPU and memory (DRAM). Repeated memory access operations are executed in the fast cache, and not in the main memory, provided the feature is enabled. In some cases it may be necessary to disable the cache for certain types of hardware and software because intentional program runtimes or delay times may be prevented by the fast cache.

[Disabled]	Cache is disabled
[Write Through]	Write access is not concluded until the entry has been made in main memory
[Write Back]	Write access is concluded immediately, the entry in main memory takes place in the background (default)

"Boot options" field

The following context menu appears when you select "Boot options" in the main menu:

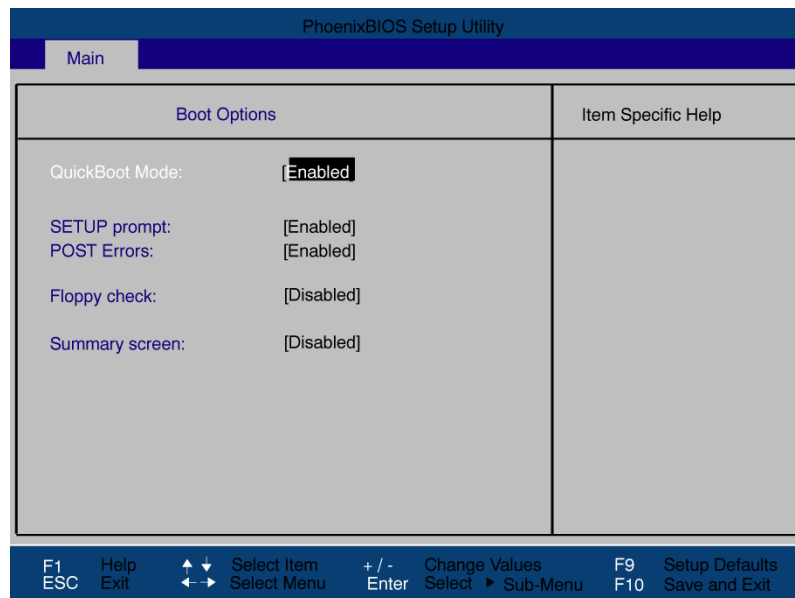

Figure 17-6 "Boot Options" field

Quick Boot Mode	Some hardware tests are skipped to speed up the boot sequence.
SETUP prompt	During the system load phase, the message Press <F2> to enter Setup or <Esc> to show boot menu is output on the bottom of the screen.
POST errors	The boot sequence is stopped if an error is detected; you must press F1 to acknowledge. Enter "Disabled" to avoid the necessity of acknowledging errors, for example, if no keyboard is connected.
Floppy check	The floppy head is stepped inward and then back to its original position during the system boot phase. This test is useful because it reinitializes the drive.
Summary screen	The most important system parameters are displayed when the system boot phase completes.

'Enabled' means that the feature is active. 'Disabled' means that the feature is inactive.

Example of a summary screen:

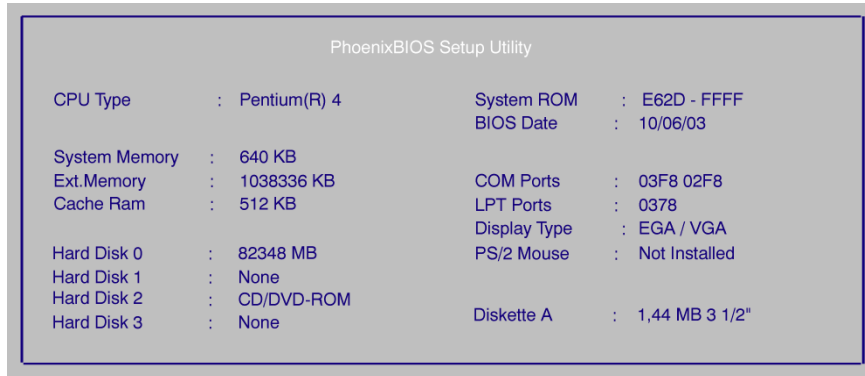

Figure 17-7 Summary Screen (Example)

The Summary screen appears when the system boot phase completes.

"Keyboard features" field

The following submenu appears when you select the option "Keyboard features" in the main menu:

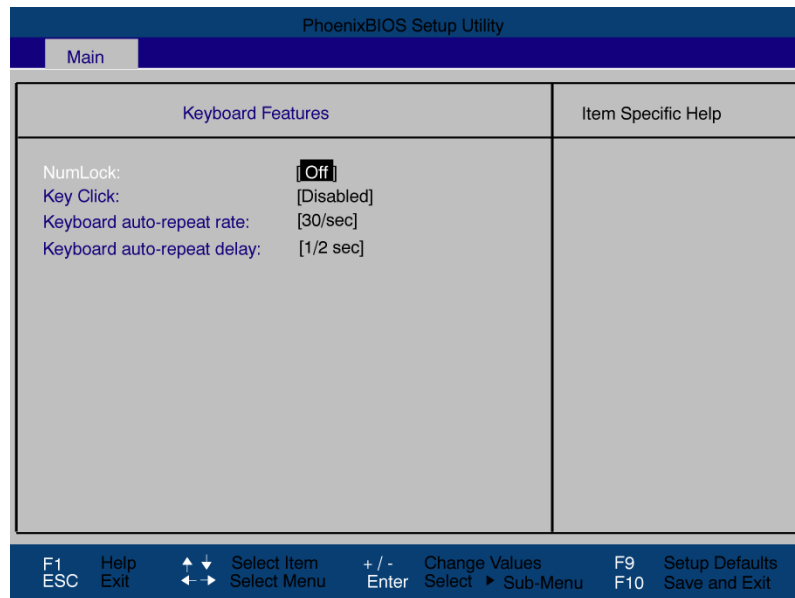

Figure 17-8 "Keyboard Features" submenu (Example)

Numlock	Switches Numlock on or off following power on.
Key Click	A keystroke can be heard with a "CLICK".
Keyboard auto-repeat rate	Increase in automatic key repeat rate
Keyboard auto-repeat delay	On-delay of automatic keyboard repeat

"Hardware options" field

The following submenu, for example, appears when you select "Hardware options" in the main menu:

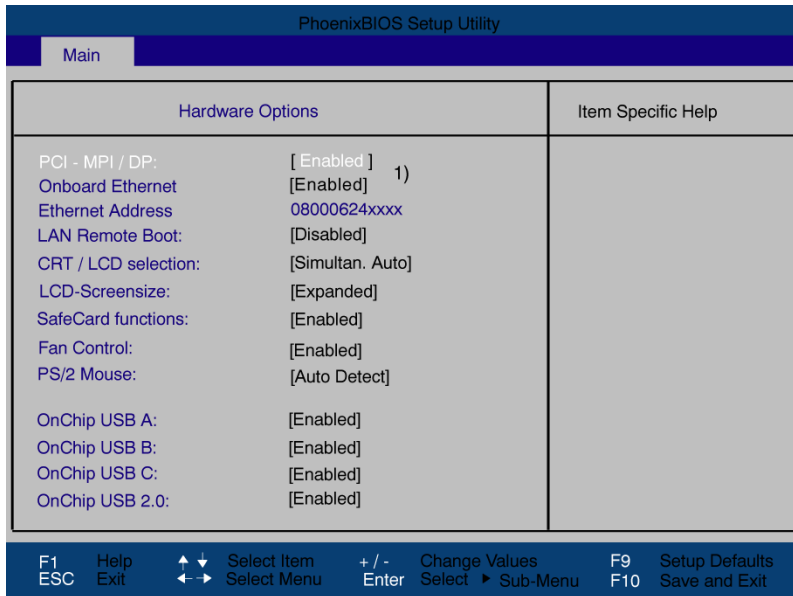

Figure 17-9 "Hardware Options" submenu (Example)

The parameters of the interfaces present on the motherboard are set here.

Entry	Meaning	
PCI-MPI/DP ¹	Enables the CP5611-compatible MPI/DP interface. The resources are managed by the BIOS PCI Plug&Play mechanism.	
On-board Ethernet	[Enabled]	The Ethernet interface on the motherboard is enabled.
	[Disabled]	The Ethernet interface on the motherboard is disabled.
Ethernet Address	Shows the individual Ethernet address.	

¹⁾ Optional product feature

Entry	Meaning	
LAN Remote Boot	[Enabled]	Booting via a connected LAN is possible. The respective boot source is displayed as Intel® Boot-Agent in the boot sequence menu.
	[Disabled]	Booting via LAN is not possible.
SafeCard functions	[Enabled]	On-board monitoring functions are enabled.
	[Disabled]	No monitoring functions.
	The relevant driver and the application must be started for operation of the monitoring functions.	
CRT / LCD selection	[CRT only]	A CRT monitor is addressed, or a DVI LCD monitor, if it is connected to the DVI ports when the system boots up.
	[LCD only]	The internal LVDS interface or the digital DVI interface is enabled, if a valid display ID was read during the boot sequence; if not, the procedure as for 'CRT only' applies.
	[Simultan. Auto]	The two interfaces, CRT and LVDS, are activated when a CRT monitor is connected with valid display detection. The external monitor is only enabled for operation if it is connected and detected at the start of the boot sequence. Data are not output to an external monitor which is not connected until after the boot sequence.
	[Simultan. Forced CRT]	Like [Simultan. Auto]. In this case, however, the CRT output is always enabled, irrespective whether CRT is connected or not.
	DVI LCD and LVDS displays cannot be operated in parallel; LVDS takes priority over DVI!	
LCD screen size	[Normal]	The presentation of text and the graphic modes are not expanded to the full screen size.
	[Expanded]	The text-based and graphic modes are expanded to the maximum possible full screen size.
Fan control	[Enabled]	The fan speed is controlled based on the temperature.
	[Disabled]	The fan always runs at full speed.
PS/2 mouse	[Enabled]	The PS/2 port is enabled. The PS/2 mouse is thus enabled. IRQ 12 is assigned.
	[Disabled]	The PS/2 port is disabled, IRQ12 is available.
	[Auto Detect]	The system automatically detects the mouse. Invariably, changes to this interface do not come into effect until the PC is switched off and on again.

Entry	Meaning	
On-chip USB A	[Enabled]	On-chip USB A determines the function of USB ports 0 and 1. On-chip USB A occupies PCI IRQ Channel 1. On-chip USB A port 0 is located on the front interface socket X44, port 1 on the bottom of the device rear X36. Users cannot edit this value.
OnChip USB B	[Enabled]	On-chip USB B determines the function of USB ports 2 and 3. On-chip USB B occupies PCI IRQ Channel 2. On-chip USB B port 3 is located on internal X2033. Port 2 is located on the bottom of the device rear X36.
	[Disabled]	The interface is disabled, resources are released and can be used otherwise.
On-chip USB C	[Enabled]	On-chip USB C occupies PCI IRQ channel 3. On-chip USB C Port 5 is located at the front interface socket X2034.
	[Disabled]	The interface is disabled, resources are released and can be used otherwise.
On-chip USB 2.0	[Enabled]	USB 2.0 is enabled for ports 0 to 5. OnChip USB 2.0 is allocated to PCI IRQ channel 4. Accessible are only the the USB ports 1 and 2 on the top/bottom of the rear panel of the device, or USB 5 on the front panel.
	[Disabled]	The USB interfaces on port 0 to 5 support only USB 1.1 and occupy resources as described earlier.

17.6.5 Advanced menu

Menu layout

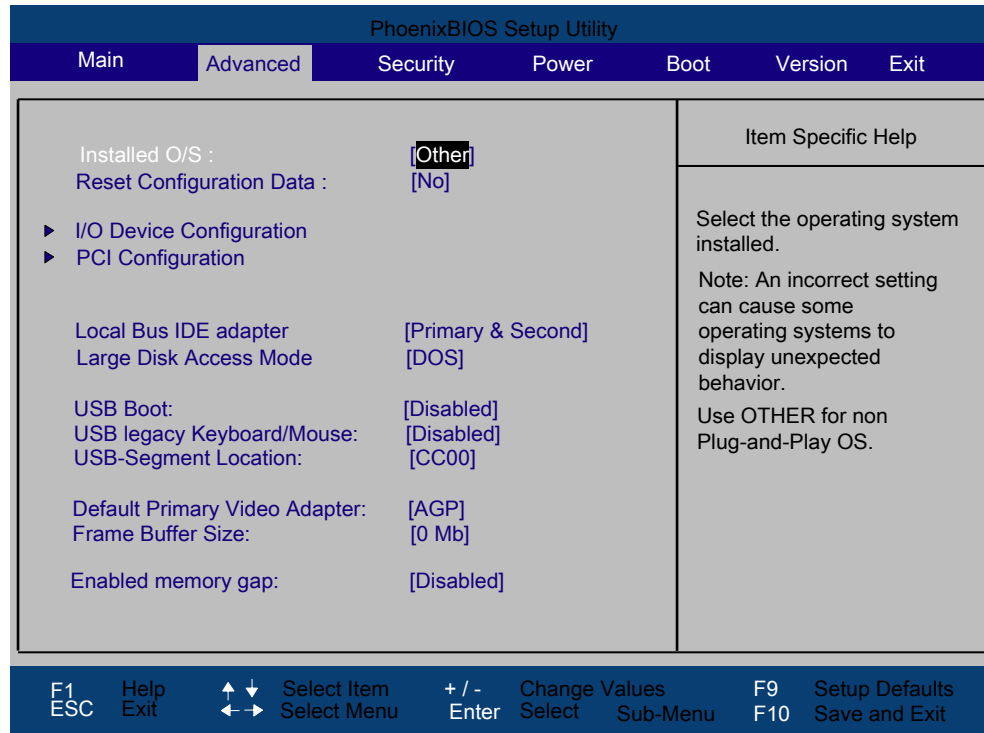

Figure 17-10 Advanced menu

Settings in the Advanced menu

Installed O/S	Plug&Play means that all modules are automatically detected and installed, providing they support the Plug&Play functionality.	
	[Other]	BIOS handles the entire Plug&Play capability, default setting.
	[Win95]	BIOS handles the entire Plug and Play capability
	[Win98]	The operating system handles some of the Plug&Play functions.
	[WinMe]	The operating system handles the Plug&Play functions.
	[Win/2000/XP]	The operating system handles the Plug&Play functions.
Reset configuration data	[Yes]	All installations under Plug and Play are deleted and the configuration is retriggered the next time the system boots. The entry is then reset to [No]. System components that do not support Plug&Play have to be entered manually.
	[No]	The Plug&Play system components are initialized after the next system start.
Local bus IDE adapter	[Primary] [Secondary]	One IDE interface for max. two drives.
	[Primary & Secondary]	Two IDE interfaces for max. four drives.
	[Disabled]	No local IDE interface.
Large disk access mode	[DOS]	The drive tables are adapted for DOS access operations in accordance with Enhanced IDE.
	[OTHER]	The tables are not adapted.
USB boot:	This function defines whether the operating system can be booted from a USB device.	

USB legacy keyboard/mouse	[Disabled]	Disables Legacy Universal Serial Bus support
	[Enabled]	This function determines whether a USB keyboard or USB mouse can be used with software or tools on an MS-DOS platform (e.g. SIMATIC PC/PG Image Partition Creator). The ISA bus is disabled when this option is set. The USB Boot function must be enabled to allow booting from a USB device, or if the system is to be operated without USB support with a USB keyboard or USB mouse. The USB Legacy Keyboard/Mouse function also needs to be enabled in addition to USB Boot (Enable), if operating systems without USB support are operated with a USB keyboard or mouse. The "Post errors" function must be disabled in the Main menu -> Boot options of the BIOS setup to enable operation only with USB keyboard and USB mouse and automatic system startup.
USB segment location	[CC00]	Memory segment selection in the case of resource shift address CC00
	[DC00]	Memory segment selection in the case of resource shift address DC00
Default primary video adapter	[AGP]	BIOS messages are output via the onboard AGP interface.
	[PCI]	BIOS messages are output via installed PCI cards.
Frame buffer size	[8Mb] [16Mb] [32MB] [None]	The frame buffer size can be adapted to the graphics requirement of your application.
Enable memory gap	[Disabled]	The onboard RAM is fully available.
	[Enabled]	A 1 MB area of the RAM beginning at 15 MB (address F0 0000 - FF FFFF) can be used by auxiliary ISA cards.

"I/O device configuration" submenu

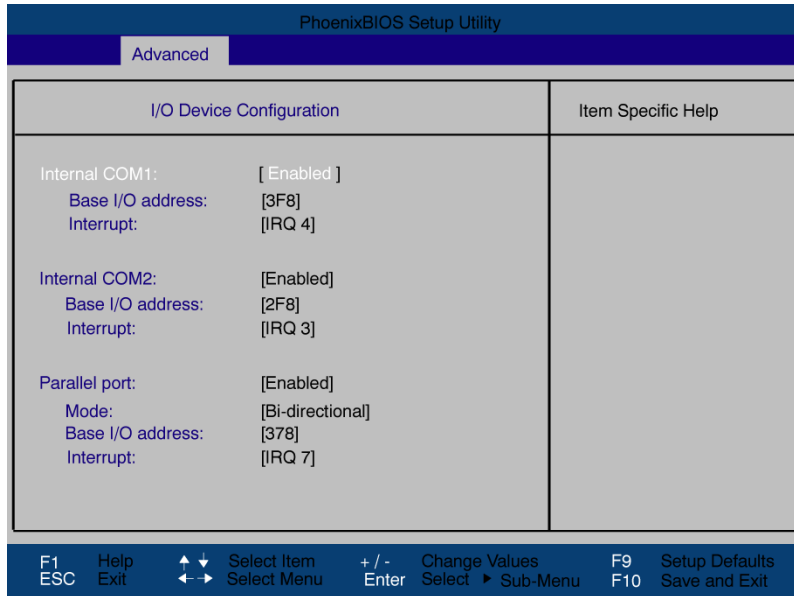

Figure 17-11 COM/LPT configuration submenu

The resources used by an interface are released when you disable the interface in question. The I/O addresses and interrupts are pre-assigned; it is advisable not to change these default assignments.

Internal printer port LPT1

Mode: Use this setting to set the operating mode of the printer port. Refer to the table below to ensure that the setting matches the data output device you connected to the printer port.

Configurable mode	Properties
Output Only Standard Parallel Port - uni-directional (SPP)	<ul style="list-style-type: none"> Standard setting for the 8 bit parallel transfer according to IEEE1284 specifications Feedback of the output device is only possible via the control cables
Bi-directional Standard Parallel Port - bi-directional	as for SPP – uni-directional, however: <ul style="list-style-type: none"> Feedback of the output device is also possible via the 8 bit data cables
EPP enhanced parallel port	<ul style="list-style-type: none"> Enhanced parallel port (data transfer rate from 500 Kbps up to 2 Mbps) Hardware handshake different devices can be addressed

"PCI configuration" submenu

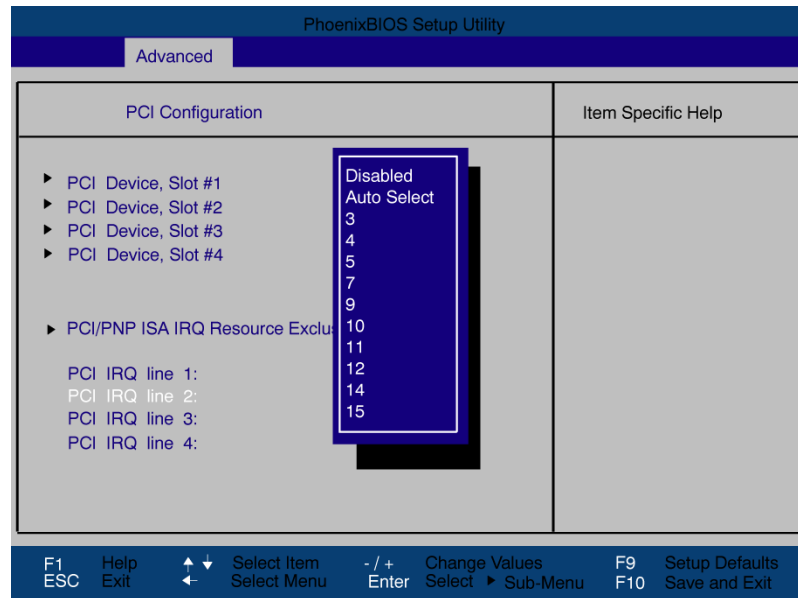

Figure 17-12 PCI configuration submenu (example)

"PCI Devices" field

If the PCI devices field is selected, the following submenu appears:

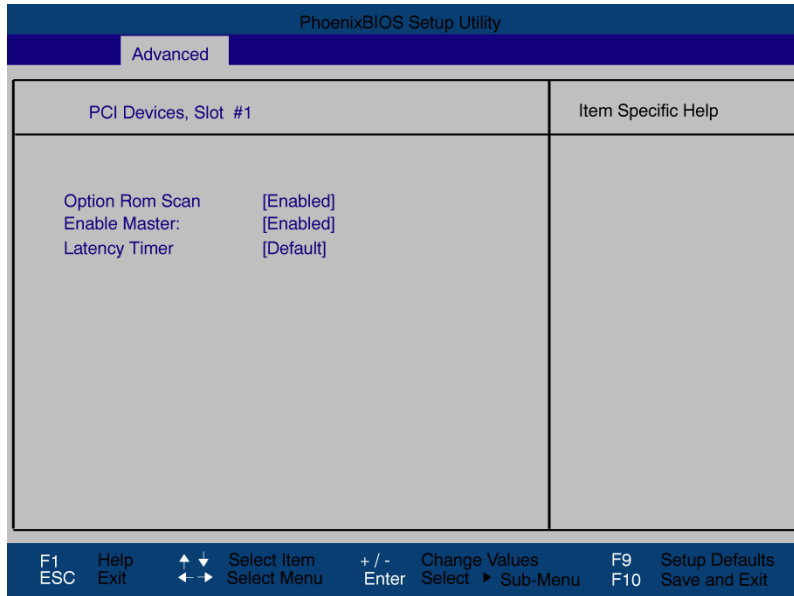

Figure 17-13 PCI devices submenu, slot #1

ROM scan option:	[Enabled]	The ROM option of the PCI module (if present) is enabled
	[Disabled]	The ROM option of a PCI module is disabled.
Enable master	[Enabled]	This slot can be assigned PCI master functions
	[Disabled]	This slot can only operate as PCI slave
Latency timer	[Default]	The number of active PCI clock cycles of the master modules is determined by this module
	[0020H to 00E0H]	These settings are used to set the maximum number of active PCI clock cycles to the selected value
	You should only use a value different from the default if the module or its application requires it.	

"IRQ resource exclusion" submenu

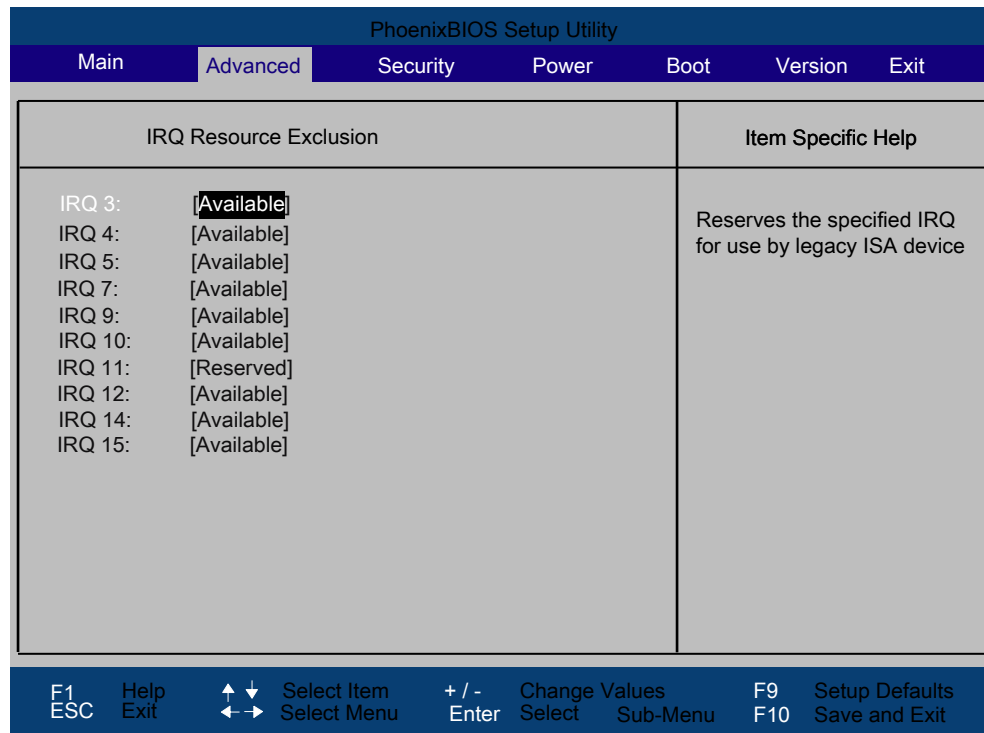

Figure 17-14 IRQ Resource Exclusion submenu (example)

Available means that the plug and play mechanism in BIOS can allocate the IRQ to plug and play submodules or motherboard functions.

Use the 'Reserved' setting only if the interrupt has to be assigned specifically to submodules with no Plug and Play capability.

"PCI IRQ channels" field

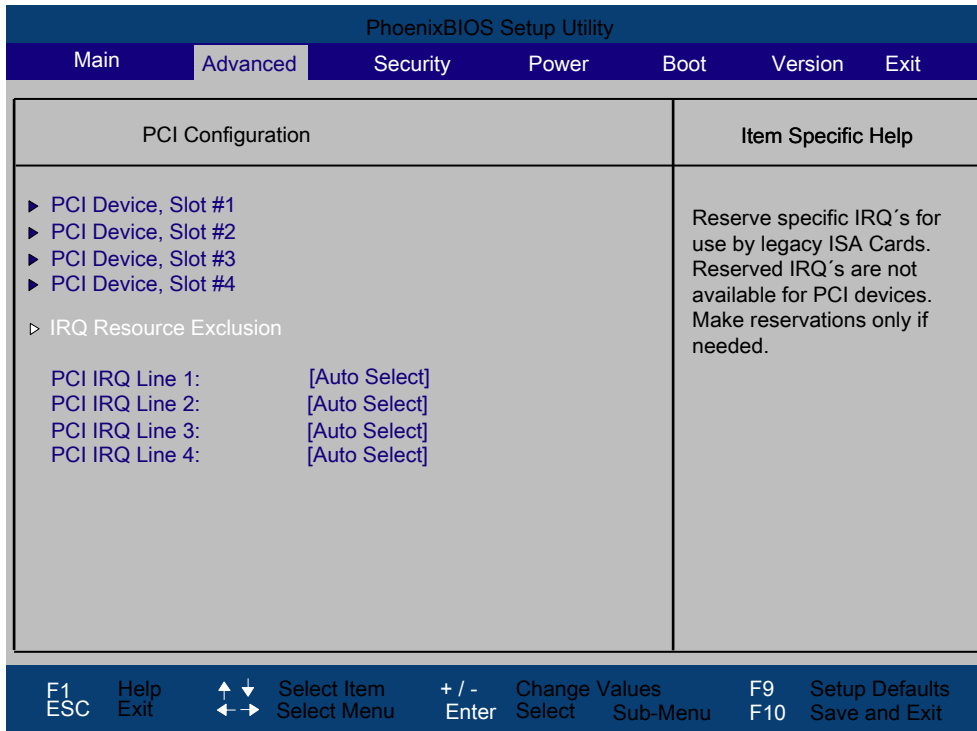

Figure 17-15 The PCI IRQ channel field

Disabled	No interrupt possible for the selected PCI IRQ channel
AutoSelect	Plug and Play mechanism in BIOS selects unassigned interrupts and allocates them to the on-board PCI devices.
3 to 15	The selected PCI IRQ channel is assigned permanently to the selected interrupt. You should only select this setting if this is specified in the documentation for your application.

Assignment of the PCI IRQ channels to the PCI slots.

Box PC 840	PCI modules interrupt assignment (PCI IRQ) in:			
Module interrupt (Pin No.)	Slot 1	Slot 2	Slot 3	Slot 4
INT - A (A6)	channel 1	channel 2	channel 3	channel 4
INT - B (B7)	channel 2	channel 3	channel 4	channel 1
INT - C (A7)	channel 3	channel 4	channel 1	channel 2
INT - D (B8)	channel 4	channel 1	channel 2	channel 3

Bold letters indicate the master interrupt of the slot module

17.6.6 Security menu

You can only edit the fields enclosed in square brackets. Two passwords can be assigned to protect your PC from unauthorized use. The Supervisor password can be used to restrict usage of the hard disk.

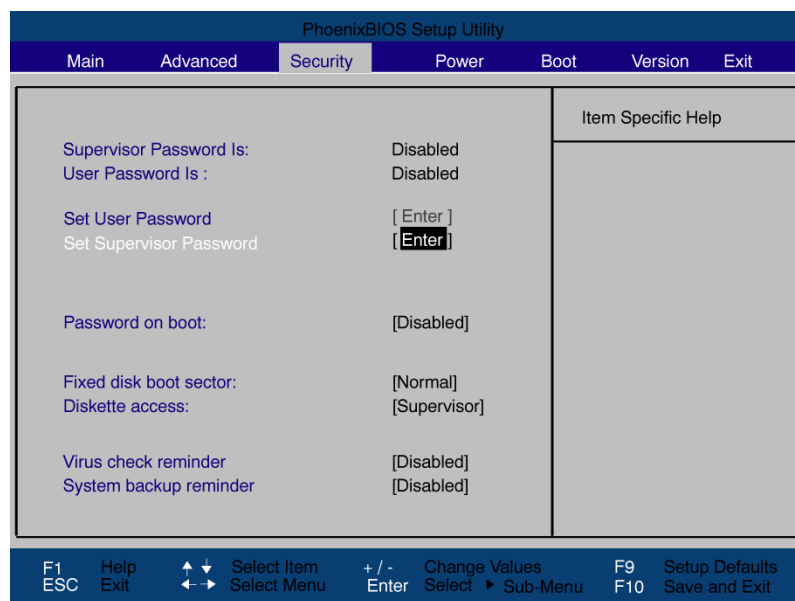

Figure 17-16 Security menu

User password is	Disabled	The password is disabled.
	Enabled	Certain Setup fields are thus configurable by the user, including the user password.
	The field resets automatically from [Disabled] to [Enabled] when the password is entered.	
Set supervisor password	This field opens the dialog box for entering a password. Once it has been entered, the supervisor password can be changed or deleted by pressing "Return" and thus deactivated.	
Set user password	This field opens the dialog box for entering a password. Once it has been entered correctly, the user password can be changed or deleted by pressing "Return" and thus deactivated.	
Password on boot	[Disabled]	No password required for system boot.
	[Enabled]	Supervisor or user password must be entered for system boot.
Fixed disk boot sector	[Normal]	All types of hard-disk access are permitted.
	[Write protect]	the user cannot install an operating system. This is a way of protecting against boot viruses.
Floppy disk drive access	This mode of protection is not enabled unless "Password on boot " is [enabled].	
	[Supervisor]	Diskette access is not possible unless the supervisor password was entered during system boot.
	[User]	Diskette access is not possible unless the user password was entered during system boot. Attention: This function cannot be used under Windows NT/2000 Professional/XP Professional, since this operating system does not access the diskette via BIOS routines. Please use the Windows NT/2000/ Professional/XP Professional system programs for this purpose.
Virus check reminder	Outputs a virus check prompt when booting.	
	[Disabled]	No message during system startup.
	[Daily]	Daily
	[Weekly]	Every Monday
System backup reminder	[Monthly]	Every first of the month
	Outputs a message when booting requesting a system backup.	
	[Disabled]	No message during system startup.
	[Daily]	Daily
	[Weekly]	Every Monday
	[Monthly]	Every first of the month

17.6.7 Power menu

This menu has the following layout.

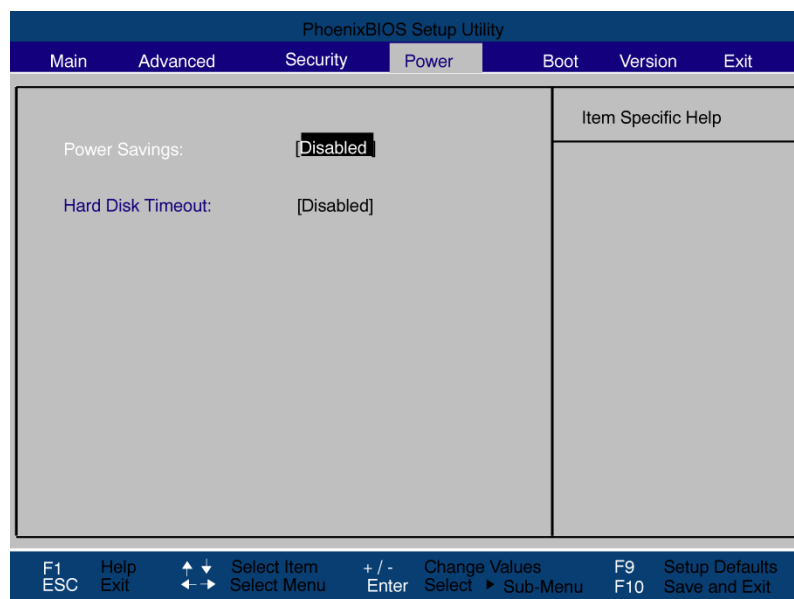

Figure 17-17 "Power" menu (Example)

The Power menu offers a number of power saver modes for environmentally friendly computing:

Power Savings	[Disabled]	no energy-saving functions
	[Customized, Maximum Power Savings, Maximum Performance]	freely selectable or default values for min./max. energy saving functions. You can set the parameters for Standby Time-out and Fixed Disk Timeout, or they are set automatically to their defaults.
Hard Disk Timeout	[Disabled]	The hard disk is not switched off.
	[6, 8, 10, 15]	Minutes after the last access the hard disk drive is switched off. The next time it is accessed, the hard disk starts spinning again after a brief delay.

17.6.8 Boot menu

This menu allows you to assign a priority for the boot devices.

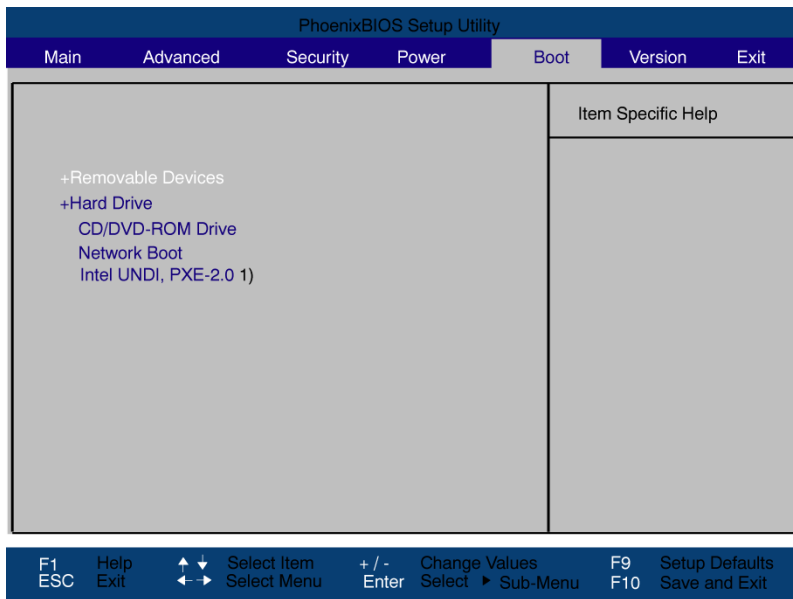

Figure 17-18 Boot Menu

¹⁾Intel® UNDI, PXE-2.0 is only displayed if, beforehand, the Wake on LAN boot function has been set to "Enabled" in the hardware options menu.

This menu lists the boot devices in groups. The group with the highest priority is at the top. To change the sequence:

Select the group with the $\uparrow \downarrow$ keys, move to the desired position with + or -.

Note

During startup the boot drive can be selected using the ESC key.

Groups marked + can contain more than one device. When you select a group marked in this way, press Enter to view the list of devices in the group.

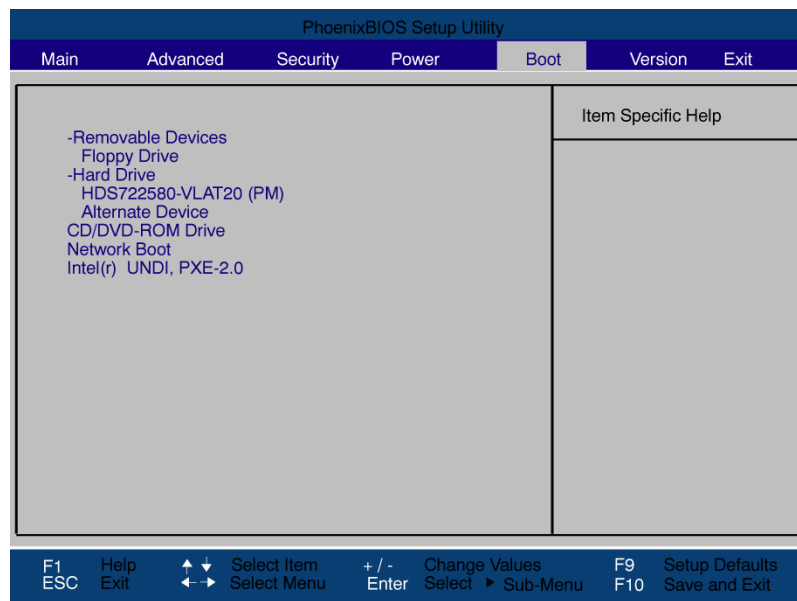

Figure 17-19 Boot menu (example)

This screen shows all possible boot devices. The device taking highest priority is listed in the first line of the relevant group. Here again, you can change the order of appearance as described above.

If a boot device is not available, the next device in the sequence is automatically checked to ascertain whether or not it is bootable.

17.6.9 Version menu

This menu contains the information you will have to quote when you send us technical questions about your system.

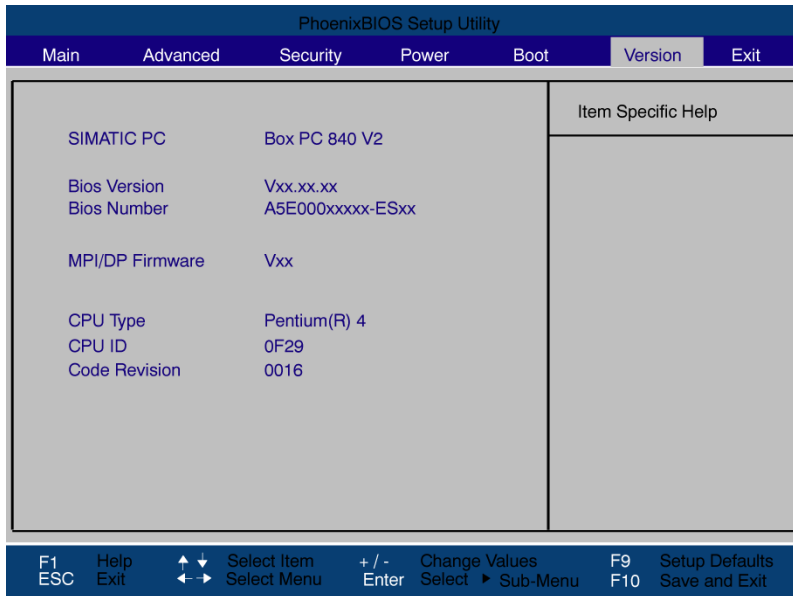

Figure 17-20 "Version" menu (Example)

17.6.10 Exit menu

The setup program is always closed from this menu.

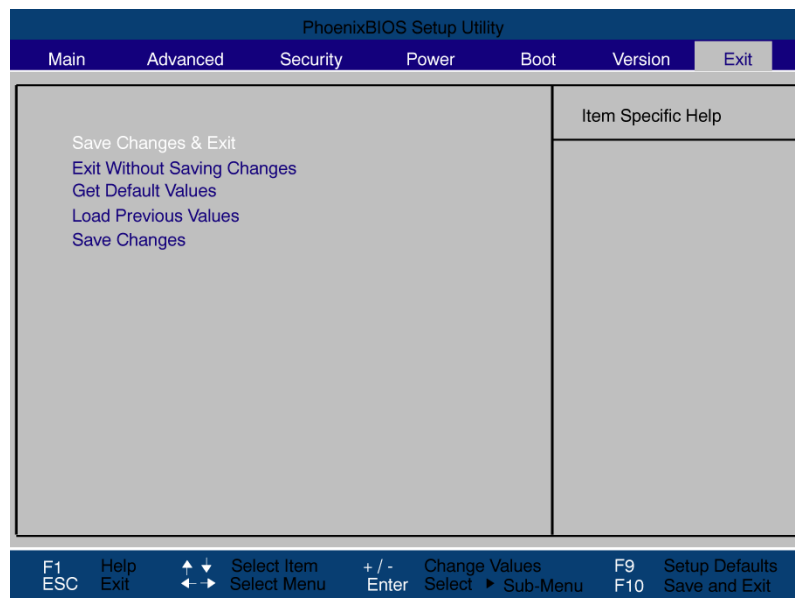

Figure 17-21 Exit menu

Save Changes & Exit	All changes are saved; a system restart is carried out with the new parameters.
Discard Changes & Exit	All changes are discarded and the system performs a restart based on the old parameters.
Get Default Values	All parameters are set to safe values.
Load Previous Values	The last saved values are reloaded.
Save Changes	Save all Setup settings.

17.6.11 BIOS setup default settings

Documenting your device configuration

If you have changed any default settings in Setup, you can enter them in the following table. You can then refer to these entries for any future hardware modifications.

Note

Print out the table below and keep the pages in a safe place once you made your entries.

BIOS Setup default settings

System parameters	Defaults	Custom entries
-------------------	----------	----------------

Main		
System Time	hh:mm:ss	
System Date	MM/DD/YYYY	
IDE Channel 0 Master	257MB	
IDE Channel 0 Slave	None	
SATA Port 0	120GB SATA1	
SATA Port 1	None	
SATA Port 2	None	
SATA Port 3	None	
Memory Cache	Write Back	

Boot Options		
Quick Boot Mode	Enabled	
SETUP prompt	Enabled	
POST Errors	All, but not keyboard	
Summary screen	Enabled	
Diagnostic screen	Enabled	
Post Code/Status	LPC Bus	

Keyboard Features		
Numlock	On	
Key Click	Disabled	
Keyboard auto-repeat rate	30/sec	
Keyboard auto-repeat delay	½ sec	

Hardware Options		
PCI-MPI/DP	Enabled	
On-board Ethernet 1	Enabled	
Onboard Ethernet 1 Address	08000624xxxx	
On-board Ethernet 1 Remote Boot	Disabled	
On-board Ethernet 2	Enabled	
Onboard Ethernet 2 Address	08000624xxxx	
On-board Ethernet 2 Remote Boot	Disabled	
SafeCard functions	Enabled	
Fan Control	Enabled	
CRT / LCD selection	Simultan. Auto	

Advanced		
Installed O/S	Other	
Reset Configuration Data	No	
Local bus IDE adapter	Primary	
Legacy USB support	Enabled	

I/O Device Configuration		
Internal COM 1	Enabled	
Base I/O address	3F8	
Interrupt	IRQ 4	

PCI Configuration		
PCI Device Slot 1		
ROM scan option:	Enabled	
Enable Master	Enabled	
Latency timer	Default	
PCI Device Slot 2		
ROM scan option:	Enabled	
Enable Master	Enabled	
Latency timer	Default	

SATA/PATA Configuration		
PATA Controller:	Enabled	
SATA Controller mode	Enhanced	
AHCI Configuration	Disabled	
RAID support	Disabled	

Security		
Supervisor Password Is	Disabled	
User Password is	Disabled	
Set User Password	Enter	
Set Supervisor Password	Enter	
Password on boot	Disabled	
Fixed disk boot sector	Standard	

Boot		
Boot priority order:		
Excluded from boot order:		

Version		
SIMATIC PC	SIMATIC BoxPC627/ PanelPC677	
BIOS Version	L05.01.00.7	
BIOS Number	A5E00378214-ES000	
MPI/DP Firmware	V01	
CPU Type	Intel © Pentium M processor 2.00 GHz	
CPU ID	06D6	
Code Revision	0017	

Appendix

A.1 Certificates and guidelines

A.1.1 Guidelines and declarations

Notes on the CE marking

 The following applies to the SIMATIC product described in this documentation:

EMC directive

AC voltage supply

The devices with AC voltage supply fulfill the requirements of the EC directive "89/336/EEC Electromagnetic Compatibility" and are intended for the following fields of application in accordance to the CE marking.

Area of application	Requirement for	
	Emitted interference	Noise immunity
Industry	EN 61000-6-4: 2001	EN 61000-6-2: 2001

The device is also compliant with EN 61000-3-2:2000, harmonic currents and EN 61000-3-3:1995, voltage fluctuation and flicker.

DC power supply

This devices with DC power supply fulfill the requirements of the EC directive "89/336/EEC Electromagnetic Compatibility" and are intended for the following fields of application in accordance to the CE marking.

Area of application	Requirement for	
	Emitted interference	Noise immunity
Industry	EN 61000-6-4: 2001	EN 61000-6-2: 2001

The device is also compliant with EN 61000-3-2:2000, harmonic currents and EN 61000-3-3:1995, voltage fluctuation and flicker.

Caution

This is a system of Class A. The equipment may cause RF interference in residential areas. In this case, the operating company may be held liable for taking appropriate measures.

Low-voltage directive

The devices with AC power pack complies with the requirements of EC directive 73/23/EEC (Low-Voltage Guidelines). Compliance has been verified by a test in accordance with the EN 60950-1 standard. The device with DC power pack also complies with this standard but does not fall within the area of validity of the EU low-voltage directive.

Declaration of conformity

The EC declaration of conformity and the corresponding documentation are made available to authorities in accordance with the EC directives stated above. The declaration is available for download from the Internet at <http://www.siemens.com/asis> under "Support".

Click on "Software Tools & Downloads" on "Overview Panel PCs" You can find the certification under Approvals/Certificates.

Design guidelines

Adhere to the installation guidelines and safety instructions given in this documentation during commissioning and operation.

Connecting peripherals

The requirements regarding noise immunity to EN 61000-6-2:2001 are met when you connect a peripheral suitable for an industrial environment. Always use shielded cables to connect peripherals.

A.1.2 Certificates and approvals

DIN ISO 9001 certificate

The quality assurance system for the entire product process (development, production, and marketing) at Siemens fulfills the requirements of ISO 9001 (corresponds to EN 29001: 1987).

This has been certified by DQS (the German society for the certification of quality management systems).



EQ-Net certificate no.: 1323-01

Software License Agreement

The device can be supplied with or without preinstalled software. For devices with preinstalled software, please note the relevant license agreements.

Certification for the United States and Canada

Safety

One of the following markings on a device is indicative of the corresponding approval:	
	UL-listed, approval from Underwriters Laboratories (UL) for United States and Canada: with abbreviation 'I.T.E.' in accordance with binational standard UL 60950-1 / CAN/CSA-22.2 No. 60950-1, with abbreviation 'IND.CONT-EQ' in accordance with standards UL 508 and CSA C22.2. No. 14-5
	UL recognition mark: Components that cannot be operated autonomously, approved by UL

EMC

USA	
Federal Communications Commission Radio Frequency Interference Statement	This equipment has been tested and found to comply with the limits for a Class A digital device, pursuant to Part 15 of the FCC Rules. These limits are designed to provide reasonable protection against harmful interference when the equipment is operated in a commercial environment. This equipment generates, uses, and can radiate radio frequency energy and, if not installed and used in accordance with the instruction manual, may cause harmful interference to radio communications. Operation of this equipment in a residential area is likely to cause harmful interference in which case the user will be required to correct the interference at his own expense.
Shielded cables	Shielded cables must be used with this equipment to maintain compliance with FCC regulations.
Modifications	Changes or modifications not expressly approved by the manufacturer could void the user's authority to operate the equipment.
Conditions of operations	This device complies with Part 15 of the FCC Rules. Operation is subject to the following two conditions: (1) this device may not cause harmful interference, and (2) this device must accept any interference received, including interference that may cause undesired operation.

CANADA	
Canadian Notice	This Class A digital apparatus complies with Canadian ICES-003.
Avis Canadian	Cet appareil numérique de la classe A est conforme à la norme NMB-003 du Canada.

A.1.3 Electrostatic charging of individuals

Anyone who is not connected to the electrical potential of their surroundings can be electrostatically charged.

The figure below shows the maximum electrostatic voltages that can accumulate in a person who is operating equipment when he/she comes into contact with the materials indicated. These values comply with the specifications of IEC 801-2.

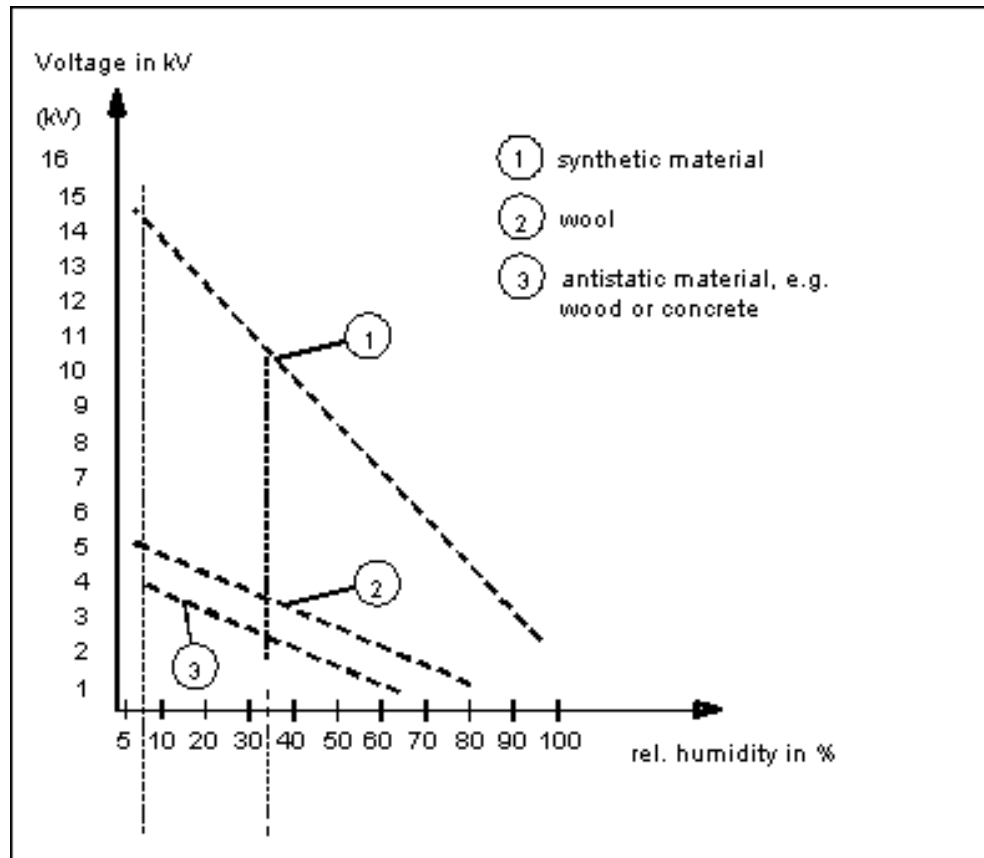

Figure A-1 Electrostatic voltages with which an operator can be charged.

A.2 Additional support

Do you have additional questions regarding use of the described products, which are not answered in the documentation? Then, contact the Siemens representative or office nearest you.

- Your Siemens representative:
["http://www.siemens.com/automation/partner"](http://www.siemens.com/automation/partner)
- Access to available technical documentation for individual SIMATIC products and systems:
["http://www.siemens.de/simatic-tech-doku-portal"](http://www.siemens.de/simatic-tech-doku-portal)
- Online catalog and online ordering system:
["http://mall.ad.siemens.com/"](http://mall.ad.siemens.com/)

Training center

To help you get started with automation technology and systems, we offer a variety of courses. Contact your regional training center or the central training center in D-90327 Nuremberg.
Phone: +49 (911) 895-3200.
Internet: <http://www.sitrain.com>

Technical Support

You can access technical support for all A&D projects via the following:

- Support Request form on the web:
["http://www.siemens.de/automation/support-request"](http://www.siemens.de/automation/support-request)
- Phone: + 49 180 5050 222
- Fax: + 49 180 5050 223

Additional Technical Support information:
["http://www.siemens.com/automation/service"](http://www.siemens.com/automation/service).

Service & Support on the Internet

In addition to our documentation, our complete know-how is available online on the Internet at:

["http://www.siemens.com/automation/service&support"](http://www.siemens.com/automation/service&support)

Here you will find:

- Our newsletter containing up-to-date information on your products.
- The documents you need via our Search function in Service & Support.
- A forum for global information exchange by users and specialists.
- Your local Automation & Drives representative.
- Information about on-site service, repairs, and spare parts. Much more can be found under "Services".

ESD directives

B.1 ESD guideline

What does ESD mean?

Almost all electronic modules are equipped with highly integrated components and elements in MOS technology. For technological reasons, these electronic components are very sensitive to overvoltages and, consequently, to electrostatic discharge. These components are therefore marked as follows:

- **ESD: Electrostatically Sensitive Devices**
- **ESD:** Internationally recognized marking for components and modules susceptible to electrostatic discharge

The following symbols on switch cabinets, module carriers or packaging indicate their susceptibility to electrostatic discharge:



ESD components are destroyed by voltage and energy far below the limits of human perception. Voltages of this kind occur as soon as a device or an assembly is touched by a person who is not electrostatically discharged. ESD components which were subject to such voltage are usually not recognized immediately as being defective, because the malfunction does not occur until after a longer period of operation.

Note

More information is located on the rating plate. The rating plate is described in the chapter "Planning use."

Precautions against electrostatic discharge

Most plastics can be charged easily. Therefore, keep plastics away from ESD components!

When working with electrostatically sensitive components, make sure that the person, the workstation and the packaging are properly grounded. Conduct the electrostatic charge away from your body by touching the mounting plate for the interfaces, for example.

Handling ESD modules

As a rule: Only touch ESD components if unavoidable due to necessary tasks.

Only touch the components when the following holds true:

- You are permanently grounded by means of an ESD armband.
- You are wearing ESD shoes or ESD shoes grounding protective strips in connection with ESD floors.

Before you touch an electronic assembly, your body must be discharged. Touch a conductive object immediately beforehand, e.g. a bare metal part of a control cabinet or the water pipe.

Do not allow chargeable, highly insulated materials, e.g. plastic films, insulating tabletops, synthetic clothing fibers, to come into contact with ESD components.

Place ESD components only on conductive surfaces (work surfaces with ESD surface, conductive ESD foam, ESD packing bag, ESD transport container).

Do not expose ESD components to visual display units, monitors or televisions. Maintain a distance of at least 10 cm to screens.

Handle flat components only by their edges. Do not touch component connectors or conductors. This prevents charges from reaching and damaging sensitive components.

Measuring and modifying ESD components

Measure the ESD component under the following conditions only:

- The measuring device is grounded with a protective conductor, for example.
- The probe on the electrically isolated measuring device has been discharged, e.g. by touching the bare metal of a part of the control cabinet.
- Your body is discharged. To do so, touch a grounded metallic object.

Solder only with grounded soldering irons.

Shipping ESD modules

Always store or ship ESD components in conductive packaging, e.g. metallized plastic boxes or metal cans. Leave the components and parts in their packaging until installation.

If the packaging is not conductive, wrap the ESD component in a conductive material, e.g. rubber foam, ESD bag, household aluminum foil, or paper, before packing. Do not wrap the ESD component in plastic bags or plastic film.

In ESD components containing installed batteries, make sure that the conductive packaging does not touch the battery connectors or short circuit. Insulate the connectors with suitable material.

List of abbreviations / acronyms

C.1 Abbreviations

ANSI	American National Standards Institute
ASCII	American Standard Code for Information Interchange
B	Width
BIOS	Basic Input Output System
CD-ROM	Compact Disc – Read Only Memory
CPU	Central Processing Unit
DC	Direct Current
DHCP	Dynamic Host Configuration Protocol
DNS	Domain Name Service
DP	Distributed I/O
DSN	Data Source Name
DVD-ROM	Digital Versatile Disc – Read Only Memory
ESD	Electrostatic Sensitive Devices
EMC	ElectroMagnetic Compatibility
H	Height
HF	High Frequency
HMI	Human Machine Interface
IF	Interface: Interface
LCD	Liquid Crystal Display: Liquid crystal display
LED	Light Emitting Diode: Light emitting diode
Mbps	Megabits per second
PC	Personal Computer
PG	Programming device
PPI	Point to Point Interface SIMATIC S7
PS/2	Personal System 2
PLC	Programmable logic controller
T	Device depth
TCP/IP	Transmission Control Protocol/Internet Protocol
USB	Universal Serial Bus
VGA	Video Graphics Array

Glossary

ATAPI CD-ROM Drive

AT-Bus Attachment Packet Interface (connected to AT bus) CD-ROM drive

Automation device (AG)

The programmable logical controllers (PLC) of the SIMATIC S5 system consist of a central controller, one or more CPUs, and various other modules (e.g. I/O modules).

Automation system (AS)

The programmable logical controllers (PLC) of the SIMATIC S7 system consist of a central controller, one or more CPUs, and various I/O modules.

Backup

Duplicate of a program, data carrier or database, used either for archiving purposes or for the protection of vital and non-replaceable data against loss when the working copy is corrupted. Some applications automatically generate backup copies of data files, and manage both the current and the previous versions on the hard disk.

Baud

Physical unit for the step speed in signal transmission. Defines the number of transferred signal states per second. With only two states, one baud is equivalent to a transmission rate of 1 bps.

BEEP code

If the BIOS detects a boot error, it outputs an audible warning based on the current test result

Boot diskette

A diskette that contains a boot sector and an initial loader for the operating system. This can be used to load the operating system from the disk.

Booting

Start or restart of the computer. During booting the operating system is transferred from the system data carrier to the work memory.

Cache

High-speed access buffer for interim storage (buffering) of requested data.

CE marking

Communauté Européene The CE symbol confirms the conformance of the product with all applicable EC directives, e.g. the EMC directive.

Chipset

Located on the motherboard, connects the processor with the RAM, the graphic controller, the PCI bus, and the external interfaces.

Cold start

A start sequence, starting when the computer is switched on. The system usually performs some basic hardware checks within the cold start sequence, and then loads the operating system from the hard disk to work memory -> boot

COM interface

The COM interface is a serial V.24 interface. The interface is suitable for asynchronous data transfer.

Configuration files

These are files containing data which define the configuration after restart. Examples of such files are CONFIG.SYS, AUTOEXEC.BAT and the registry files .

Configuration software

The configuration software updates the device configuration when new modules are installed . This is done either by copying the configuration files supplied with the module or by manual configuration using the configuration utility.

Controller

Integrated hardware and software controllers that control the functions of certain internal or peripheral devices (for example, the keyboard controller).

Device configuration

The configuration of a PC or programming device contains information on hardware and device options, such as memory configuration, drive types, monitor, network address, etc. The data are stored in a configuration file and enable the operating system to load the correct device drivers and configure the correct device parameters. . If changes are made to the hardware configuration, the user can change entries in the configuration file using the SETUP program. .

Disc-at-once

With this burning technique, data are written to a CD in a single session, and the CD is then closed. Further write access is then no longer possible.

Drivers

Program parts of the operating system. They adapt user program data to the specific formats required by I/O devices such as hard disk, printers, and monitors.

EMC directive

Directive concerning **E**lectromagnetic **C**ompatibility. Compliance is confirmed by the CE symbol and the EC certificate of conformity.

Energy management

The energy management functions of a modern PC allow individual control over the current consumption of vital computer components (e.g. of the monitor, hard disk and CPU), by restricting their activity based on the current system or component load. Energy management is of particular importance for mobile PCs.

Energy options

The energy options can be used to reduce energy consumption of the computer, while keeping it ready for immediate use. This can be configured in Windows by selecting Settings > Control Panel > Energy options.

ESD guidelines

Directive for using electrostatic sensitive components.

Ethernet

Local network (bus structure) for text and data communication with a transfer rate of 10/100 Mbps.

Formatting

Basic partitioning of memory space on a magnetic data carrier into tracks and segments. Formatting deletes all data on a data carrier. All data carriers must be formatted prior to their first use.

Gender changer

Using the gender changer (25-pin / 25-pin), the COM1/V24/AG interface of the SIMATIC PC family can be converted to the usual 25-pin male connector.

Hard disks

Hard disks represent a form of magnetic disk storage medium (Winchester drives, hard disks) with integrated magnetic disks.

Hot swapping

The SATA interface gives the device's hard drive system hot-swap capability. The prerequisite for this is a RAID1 system, comprising a SATA RAID controller (onboard or as a slot board, and at least two SATA swap frames. The advantage of hot swapping is that defective hard disks can be replaced without the need for rebooting.

Hub

A term in network technology. In a network, a device joining communication lines at a central location, providing a common connection to all devices on the network.

Hyper Threading

HT technology enables the parallel processing of tasks. HT is only effective when all relevant system components, such as processors, operating systems and applications are supported.

Image

This refers to the image, for example, of hard disk partitions saved to a file in order to restore them when necessary.

Intel chip set 915 GM

The chip set organizes the data traffic between the main processor, working memory, cache, slots and other interfaces.

Functions of the 915 GM: Front side bus with 533 MHz, Intel® graphical media accelerator 900, support for up to 2 GB dual-channel DDR2 memories, Intel® High definition audio, Intel® display power-saving technology 2 (Intel® DPST 2)

Interface

see Interface

Interface, multi-point

MPI is the programming interface of SIMATIC S7/M7. Allows central access to programmable modules, text-based displays and OPs. The MPI nodes can intercommunicate.

LAN

Local Area Network: LAN is a local network that consists of a group of computers and other devices that are distributed across a relatively restricted range and are linked with communication cables. The devices connected to a LAN are called nodes. The purpose of networks is the mutual use of files, printers or other resources.

Legacy USB support

Support of USB devices (e.g. mouse, keyboard) on the USB ports without driver.

License key

The license key represents the electronic license stamp of a license. Siemens provides the license keys for protected software.

License key diskette

The license key diskette contains the authorizations or license keys required to enable protected SIMATIC software.

Low-voltage directive

EC directive for product safety of products operated with low voltage (AC 50V to 1000V, DV 70V to 1500V) that are not governed by other directives. Compliance is confirmed by the CE symbol and the EC certificate of conformity.

LPT interface

The LPT interface (Centronics interface) is a parallel interface that can be used to connect a printer.

Memory card

Memory cards in credit card format. Memory for user programs and parameters, for example, for programmable modules and CPs.

Module

Modules are plug-in units for PLCs, programming devices or PCs. They are available as local modules, expansion modules, interfaces or mass storage (Mass storage module).

Module bracket

The module bracket is used to fasten modules and ensure safe contact and transport. Shocks and vibrations especially affect large, heavy modules. It is therefore recommended to use the module bracket for this type of module. There are also short, compact and light modules on the market. The module bracket was not designed for these modules because the standard fastening is sufficient for them.

Motherboard

The motherboard is the core of the computer. Here, data are processed and stored, and interfaces and device I/Os are controlled and managed.

Operating system

Summarizing term describing all functions for program execution, allocation of system resources to the various user programs, and for controlling and monitoring consistency of the operating mode in cooperation with the hardware (e.g. Windows XP Professional).

Packet writing

The CD-RW is used as a diskette medium. The CD can then be read only by packet-writing compatible software or has to be finalized. Finalization of a CD closes the CD within an ISO9660 shell. You can still write to the CD-RW several times in spite of finalization. Not all CD drives can read packet-written CDs. There are restrictions to using this method in general data transfer.

PATA

An interface for hard disk drives and optical drives with parallel data transfer of up to 100 Mbps.

PC card

Trademark of the Personal Computer Memory Card International Association (PCMCIA). Designation for auxiliary cards that conform with PCMCIA specifications. A PC card that has roughly the size of a credit card can be plugged into a PCMCIA slot. Version 1 specifies cards of Type I with a thickness of 3.3 millimeters, which is conceived mainly for use as external memory. Version 2 of the PCMCIA specification also defines a card Type II with a thickness of 5 mm and a card of the Type III with a thickness of 10.5 mm. Type II cards can realize devices such as modems, fax and network interface cards. Type III cards are equipped with devices that require more space, for example wireless communication modules or rotary storage media (hard disks, for example).

PC/104 / PC/104-Plus

Two bus architectures are especially fashionable today in the industrial world. PC/104 and PC/104-*Plus*. Both are standard in single-board computers of the PC class. The electrical and logical layout of the two bus systems is identical with ISA (PC/104) and PCI (PC/104-*Plus*). Software cannot usually detect a difference between them and normal desktop bus systems. Their advantage is the compact design and the resulting space they save.

PCMCIA

Association consisting of approx. 450 member companies of the computer industry. Their focus is set on providing worldwide standards for miniaturization and flexible use of PC expansion cards, and thus to provide a basic technology to the market.

Pentium M

Intel processor type: The architecture of the processor is designed for mobile computing; the processor features superior performance characteristics for computer applications and enhanced power-saving functions

Pixel

PixElement (picture point). The pixel represents the smallest element that can be reproduced on-screen or on a printer.

Plug&Play

Generally, a reference to the ability of a computer to automatically configure the system for communication with peripheral devices (for example monitors, modems or printers). The user can plug in a peripheral and "play" it at once without manually configuring the system. A Plug&Play PC requires both a BIOS that supports Plug&Play and a Plug&Play expansion card.

POST

Self-test performed by the BIOS after the computer is switched on. Performs a RAM test and a graphic controller test, for example. The system outputs audible signals (beep codes) if the BIOS detects any errors; the relevant message indicating cause of error is output on the screen.

PROFIBUS/MPI

Process Field Bus (standard bus system for process applications)

PXE server

A **Preboot Execution Environment** server is part of a network environment and can provide software to connected computers even before they boot. This can involve operating system installations or servicing tools, for example.

RAID

Redundant Array of Independent Disks: Data storage system which is used to store data along with the error correction codes (e.g. parity bits) on at least two hard disks, in order to increase system reliability and performance. The hard disk array is controlled by management programs and a hard disk controller for error correction. The RAID system is usually implemented in network servers.

Recovery CD

Contains the tools for setting up the hard disks and the Windows operating system.

Reset

Hardware reset: Reset/restart of the PC using a button/switch.

Restart

Warm start of a computer in operating state without switching off the power supply (Ctrl + Alt + Del)

Restore DVD

The Restore DVD is used to restore the system partition or the entire hard disk to factory state if the system has crashed. The bootable DVD contains all the necessary image files. You can also create a boot disk allowing restoration via the network.

ROM

Read-Only Memory ROM is a read-only memory in which every memory location can be addressed individually. The programs or data are permanently stored and are not lost in the event of a power failure.

SCSI interface

Small Computer System Interface Interface for connecting SCSI devices (e.g. hard disk or optical drives)

Session at once

In session at once, the CD can be written to both with an audio session and a data session. The two sessions are written to at once (as in disc at once).

SETUP (BIOS Setup)

A program in which information about the device configuration (that is, the configuration of the hardware on the PC/PG) is defined. The device configuration of the PC/PG is preset with defaults. Changes must therefore be entered in the SETUP if a memory extension, new modules or a new drive are added to the hardware configuration.

Track-at-once

In track-at-once recording, a CD can be written to in bits in several sessions if the CD was not closed.

Troubleshooting

Error cause, cause analysis, remedy

V.24 interface

The V.24 interface is a standardized interface for data transmission. Printers, modems, and other hardware modules can be connected to a V.24 interface

Warm restart

The restart of a computer after a program was aborted. The operating system is loaded and restarted again. The hot key CTRL+ ALT+ DEL can be used to perform a warm start.

Windows

Microsoft Windows is a multitasking graphical user interface. Windows provides a standard graphical interface based on drop-down menus, windowed regions on the screen, and allows operation with a pointer device such as a mouse.

WLAN

Wireless LAN is a local network that transmits data via radio waves, infrared light or another wireless technology. Wireless LAN is mainly used in connection with mobile computers in the office or in factory environments.

Index

<

<Shift> key, 10-6

A

- Abbreviations, C-1
- AC voltage supply, A-1
- Accessories, 3-5
- Advanced menu
 - BIOS setup, 17-51
- Alarms, 9-10, 9-11
- Allocation
 - PCI IRQ channels, 17-25
- Approval, 1-1, 8-10, 15-6
- Approvals, A-3
- Area of application, 1-1
- Arithmetic symbols, 10-7
 - Entering, 10-7
- Assignment
 - External interfaces, 17-5
 - I/O addresses, 17-32
 - Interrupts, 17-34
 - Memory addresses, 17-35
- Authorization, 12-33
- Automatic logon, 8-11, 8-12
- Automatic updates, 9-10

B

- back up, 12-46
 - Hard disk drive, 12-46
- Backlighting, 3-2, 15-5
 - Life, 15-5
- Battery replacement, 12-26
- Beep codes, 13-3
- BIOS, 8-9
 - Advanced menu, 17-51
 - BIOS settings, 8-9
 - Boot Menu, 17-62
 - Defaults, 17-66
 - Main menu, 17-41
 - Menu layout, 17-39

- Security menu, 17-59
- Boot options, 17-45
- Boot sequence
 - Error messages, 13-1
- Booting
 - Error messages, 13-1
- Brief description, 3-1
- Burning
 - CD-R / CD-RW, 9-18
- Bus board
 - Design, 17-24

C

- Cable, 17-30
- Cable connector, 12-5
- Calibrating, 9-6
 - Touch screen, 9-6
- CD-R / CD-RW
 - Operating notes, 9-18
- CE marking, 1-1
- Certificates, A-3
- CheckLanguageID, 9-15
- Checklist, 8-1
- Cleaning agents, 12-1
- Color display, 15-6
 - Technical data, 15-4, 15-5
- COM, 3-3
- COM port
 - Interfaces, 17-2, 17-5
- Commissioning, 2-6, 8-1
 - Device, 8-1
- Compatibility of the Restore DVD, 12-32
- Components, 3-5
- Computer unit, 3-1, 12-4
 - Separating from the control unit, 12-4
- Condensation, 2-6, 8-1
- Connecting, 2-4, 7-2, 9-1, 10-9, A-2
 - Connecting external keyboard, 10-9
 - Device, 7-2
 - Electrical connection, 2-4
 - Peripherals, 9-1, A-2
 - S7 automation system, 7-2
- Control and display elements, 10-17
- Control elements, 10-3

- On the key panel, 10-3
- Control unit, 3-1, 3-2, 12-4, 15-6
 - Separating from the computer unit, 12-4
- Convention, 1-2
- couple, 7-3
 - Device, 7-3
- Coupling with SIMATIC S7, 7-1
- Cover foil, 3-5
- Cursor key, 10-8

D

- Dash, 10-7
- Data exchange, 7-1
- Date, 17-41
 - BIOS setup, 17-41
- DC power supply, A-1
- Decimal point, 10-7
- Defaults
 - BIOS, 17-66
- Degree of protection, 4-8
 - IP54 degree of protection, 4-8
 - IP65 degree of protection, 4-8
- Design, 3-2, 4-6, 4-12, 12-3, 15-6
 - Bus board, 17-24
 - Centralized configuration, 12-3
 - Distributed configuration, 3-2
 - EMC compliant design, 4-12
 - Motherboard, 17-1
 - Technical data for centralized configuration, 15-6
- Design guidelines, A-2
- Device, 4-12, 7-2, 7-3, 8-1, 9-1, 9-4, 10-19, 12-1, 12-4, 12-6
 - Commissioning, 8-1
 - Connecting, 7-2
 - Connecting an S7 automation system, 7-2
 - couple, 7-3
 - Disk drive, 10-19
 - EMC-compliant installation, 4-12
 - Interconnecting, 7-2
 - Interconnecting via MPI/PROFIBUS, 7-2
 - Maintaining, 12-1
 - opening, 12-9
 - Separating, 12-4, 12-6
 - Switching off, 9-4
 - Switching on, 9-1
- Device configuration, 17-66
- Device number, 4-3
 - Checking, 4-3
- DiagMonitor
 - Fan monitoring, 11-6
 - Temperature monitoring, 11-4

- Diagnostics, 14-3
 - DiagMonitor, 11-1
 - SOM (Safecard On Motherboard), 11-1
- Dimension drawing, 16-2, 16-3
- Dimensions, 4-9, 15-6, 16-2
 - Centralized configuration, 15-6
 - Panel PC 877, 16-2
- Direct control key module, 3-5, 15-5
- Disk drive, 3-4, 10-19
 - Disk drive, 10-19
- Disk drives, 15-3
- Diskette types, 10-19
- Display, 2-8, 3-1, 3-2
 - Interfaces, 17-13
 - TFT-LC display, 2-8
- Distributed, 7-1
- Download, 2-7
- Drive bay
 - Removing, 12-18
- Drive bay module, 12-16
- Drivers, 12-39
 - Installing, 12-39
- DVD-ROM
 - Operating notes, 9-18
- DVI interface, 17-12
- DVI-I, 3-3

E

- Electromagnetic compatibility, 4-12
- Electrostatic charge, A-5
- Electrostatic charging, B-2
 - Precautions, B-2
- Electrostatic Sensitive Devices, B-1
- EMC, 4-12
 - Directive, 4-12
 - EMC compliant design, 4-12
- EMC directive, A-1, A-4
 - AC voltage supply, A-1
 - DC power supply, A-1
- Entering, 10-7
 - Arithmetic symbols, 10-7
 - Sign, 10-7
 - Special characters, 10-7
- Equipotential bonding, 6-7
- Error, 14-3
- Error messages
 - Booting, 13-1
- ESD, B-1, B-2
 - Electrostatic charging, A-5
 - Guideline, B-1
 - Handling, B-2

- Measuring, B-2
 - modify., B-2
 - Shipping, B-2
 - Ethernet, 3-3, 7-1
 - Ethernet address, 4-3
 - Exit, 8-7
 - Startup, 8-7
 - Exit menu, 17-65
 - Expansion
 - Module, 12-13
 - PCI / AT cards, 12-13
 - Slots, 15-3
 - External interfaces, 17-5
- F**
- Factory state, 12-33
 - Fans
 - Monitoring, 11-6
 - FAQs, 14-3
 - Fault diagnostics, 13-3
 - Field devices, 7-1
 - Field of application, 4-1
 - Firewall, 9-10
 - Floppy disk drive
 - BIOS setup, 17-41
 - Function key, 3-2, 10-14, 15-5
 - Labeling, 10-14
 - Function keys, 10-4
- G**
- General technical data, 15-1
 - Graphic, 3-3
 - Technical data, 15-4
- H**
- Hard disk drive, 3-4, 12-46
 - back up, 12-46
 - Hardware components, 8-4
 - Hardware interrupts
 - Reserved, 17-26
 - Hardware Options, 17-48
 - BIOS setup, 17-48
 - Hotfix, 2-7
- I**
- I/O addresses
 - Assignment, 17-32
 - I/O device configuration, 17-54
 - I/O front interface, 17-16
 - Image, 12-32
 - Immunity to interference, 4-12
 - EMC compliant design, 4-12
 - EMC directive, 4-12
 - Information landscape, 1-2
 - Installation, 4-12, 15-6
 - Centralized configuration, 15-6
 - Installing the device according to EMC directive, 4-12
 - Modules, 12-13
 - Installation information, 4-4
 - Installing, 12-35, 12-39
 - Drivers, 12-39
 - Operating system, 12-35
 - Integration, 7-1
 - Ethernet, 7-1
 - PROFIBUS, 7-1
 - Interconnecting, 7-2
 - Device, 7-2
 - Interconnecting device via MPI/PROFIBUS, 7-2
 - Interface, 3-3, 7-2
 - COM, 3-3
 - DVI-I, 3-3
 - Ethernet, 3-3
 - MPI/DP interface, 7-2
 - PROFIBUS, 3-3
 - USB, 3-3, 8-13
 - VGA, 3-3
 - Interfaces, 17-4
 - Display, 17-13
 - Ethernet RJ 45, 17-2
 - Keyboard, 17-9, 17-47
 - LVDS, 17-14
 - Mouse, 17-9, 17-49
 - Parallel, 17-8
 - PROFIBUS, 15-4
 - RJ45 Ethernet, 17-49
 - Serial, 15-3, 17-6
 - USB, 15-3
 - Internal interfaces, 17-18
 - Internal printer port LPT1, 17-54
 - Interrupts, 17-34
 - Assignment, 17-34
 - IT communication, 7-1
- K**
- Key, 10-7
 - Numeric key, 10-7

Key code, 15-11
Key panel, 8-7, 10-3
 set, 8-7
Keyboard, 3-2, 10-9
 BIOS setup, 17-47
 BIOS setup, 17-47
 External keyboard, 10-9
 Features, 17-47
Keyboard table, 15-11
Keyboard variant, 3-2
Knurled screw, 12-4

L

Labeling, 10-14
 Function key, 10-14
 Softkey, 10-14
Labeling strips, 3-2, 10-14, 10-15
 Handwritten strips, 10-15
Language selection for Windows 2000 Professional, 9-16
Laser printer, 10-14
LED, 3-2
 Operating status, 3-2
LEDs, 10-1
 POWER, 10-1
 TEMP, 10-1
Liability of product nonconformance, 15-6
License key, 12-33
Lithium battery, 12-25
Lower-case letter, 10-6
 Toggling to upper-case letters, 10-6
Low-voltage directive, A-2
LPT port
 BIOS setup, 17-54
 Interfaces, 17-8
Lug, 12-5
LVDS
 Interfaces, 17-14

M

Main memory, 3-4, 15-3
Maintaining, 12-1
 Device, 12-1
Maintenance, 12-1
Mass storage, 3-4
Measuring, B-2
 ESD, B-2
Membrane keyboard, 3-1, 3-2
Memory, 3-4

Memory addresses
 Assignment, 17-35
Memory configuration, 12-11
Memory expansion, 12-10, 12-11
Memory expansion, 12-10
Minus sign, 10-7
modify., B-2
 ESD, B-2
Module, 12-10
 Installation, 12-10
Modules, 12-12
 Module retainer, 12-13
Monitoring
 DiagMonitor, 11-1
 Fans, 11-6
 SOM (Safecard On Motherboard), 11-2
 Temperature, 11-4
 Watchdog, 11-5
Motherboard, 17-1
 External interfaces, 17-5
 Internal interfaces, 17-18
 Location of the interfaces, 17-4
Mounting position, 4-6
 Permitted mounting position, 4-6
Mouse, 10-16, 15-5
 BIOS setup, 17-49
 Integrated mouse, 10-16
Mouse pointer, 10-16
 Direction, 10-16
 Speed, 10-16
MPI network, 7-2
MPI/DP, 17-30

N

Navigation, 10-8
Notation, 1-2
Note, 2-4, 2-6, 4-4
 General information, 2-6
 General Information, 12-2
 Installation guidelines, 4-4
 Safety information, 2-4

O

On / Off switch, 10-2
Online ordering system, 7-1
Open
 Device, 12-9
Operating, 10-18
 Touch screen, 10-18

Operating status, 3-2, 10-1
 Operating system, 3-4, 12-35
 Installing, 12-35
 Windows 2000 Professional, 12-30, 12-37
 Windows XP Professional, 12-30, 12-37
 Output voltage, 15-9, 15-10

P

Package contents, 4-2
 Checking, 4-2
 Packaging, 4-2
 Checking, 4-2
 Removing, 4-2
 Panel PC, 12-4
 Panel PC 877, 3-1, 16-2
 Parallel interface, 17-8
 BIOS setup, 17-54
 Partitioning
 Windows 2000 Professional, 12-30
 Windows XP Professional, 12-30
 Password
 Boot, 17-60
 Supervisor, 17-59
 User, 17-60
 PCI / AT cards
 Assignment of PCI IRQ channels, 17-58
 BIOS setup, 17-55
 PCI configuration, 17-55
 PCI devices, 17-56
 PCI IRQ channels, 17-58
 Allocation, 17-25
 PCI/PNP ISA IRQ resource exclusion, 17-57
 Peripheral, 8-13
 Peripherals, 9-1, A-2
 Connecting, 9-1, A-2
 Pin assignment of the interfaces on the motherboard
 ATX 12 V, 17-18
 ATX power supply, 17-13, 17-18
 COM1 (X30), 17-6
 COM2 (X31), 17-7
 DVI, 17-12
 Ethernet, 17-11
 Fan power supply (x41-43), 17-18
 LPT port, 17-8
 Operator panel, 17-19
 PROFIBUS/MPI, 17-10
 PS/2, 17-9
 SCSI activity, 17-18
 USB, 17-9
 USB internal, 17-18
 Pixel, 2-8

 Defective pixel, 2-8
 Plus sign, 10-7
 POST, 13-3
 Power Good Signal, 15-9, 15-10
 Power menu
 BIOS Setup, 17-61
 Power supply, 3-4
 AC voltage supply, 15-9
 DC voltage supply, 15-10
 Power requirements of the components, 17-2
 Primary master, 17-42
 BIOS setup, 17-42
 Primary Slave
 BIOS setup, 17-42
 Processor, 3-4, 15-3
 PROFIBUS, 3-3, 7-1
 Integration, 7-1
 Interfaces, 17-2
 Technical data, 15-4
 PROFIBUS/MPI interface, 17-10
 PROFIBUS-DP network, 7-2
 Protection class, 15-6
 PS/2 port
 BIOS setup, 17-49

R

Radiation, 2-4
 High frequency radiation, 2-4
 Recovery functions, 12-37
 Removing
 Drive bay, 12-18
 Repairs, 2-5, 12-7
 Replacement parts, 12-3
 Replacing
 Battery, 12-25
 Reserved hardware interrupts, 17-26
 Reset button, 10-2
 Resolution, 15-4
 Restore DVD, 12-32, 12-33
 RJ45 Ethernet, 17-11
 BIOS setup, 17-49

S

Safety information, 2-4
 Scope of maintenance, 12-1
 Scrolling, 10-8
 Secondary Master
 BIOS setup, 17-42
 Secondary slave

- BIOS setup, 17-42
- Security menu
 - BIOS setup, 17-59
- Selecting the language
 - Windows XP, 9-16
- Self test, 13-3
- Self-test, 8-2, 9-2
- Separating, 12-4, 12-6
 - Device, 12-4, 12-6
- Serial interface, 17-2
 - BIOS setup, 17-54
- Service pack, 8-11
- Service Pack, 8-12
- set, 8-5, 8-7, 9-6
 - Key panel, 8-7
 - Touch screen front, 8-5
 - Touch software, 9-6
- Setting up partitions, 12-30
- Shipping, B-2
 - ESD, B-2
- Sign, 10-7
 - Entering, 10-7
- SIMATIC S7, 7-1, 7-2, 17-30
 - Integration, 7-1
- Slide-in labels, 3-5, 15-5
- slot, 3-3
- Softkey, 3-2, 10-14
 - Labeling, 10-14
- Softkey row, 10-14
- Softkeys, 10-4
- Software, 2-7
- Software components, 8-4
 - additional software components, 8-4
- SOM, 10-1
- SOM (Safecard On Motherboard), 11-2
 - Temperature monitoring, 11-2
- Special characters, 10-7
 - Entering, 10-7
- Special codes, 13-4
- Standard, 1-1
- Startup, 8-7
 - Exit, 8-7
- State, 12-6
 - Uninstalled state, 12-6
- Status display, 10-1
- Status displays, 15-4
- Steel slot cover, 12-13
- Supply voltage, 15-1, 15-4
- Switching off, 9-4
 - Device, 9-4
- Switching on, 9-1
 - Device, 9-1

- System Date, 17-41
 - BIOS setup, 17-41
- System parameters, 17-66
- System partition, 12-33
- System resources, 17-31
 - Currently allocated system resources, 17-31
 - Interrupt assignments, 17-34
- System Time, 17-41
 - BIOS setup, 17-41

T

- Technical data, 15-1, 15-6, 15-8
- Temperature
 - Fan monitoring, 11-6
 - Monitoring, 11-4
- Temperature error, 14-3
- Temperature threshold, 10-1
- TFT technology, 3-2
- Third-party modules, 14-2
- Time, 17-41
 - BIOS setup, 17-41
- togglng, 10-6
 - between lower-case and upper-case letters, 10-6
- Tools, 12-7
- Touch screen
 - Special features, 9-7
- Touch screen, 3-1, 3-2, 9-6, 9-7
 - Calibrating, 9-6
- Touch screen
 - Maloperation, 9-7
- Touch screen, 10-18
- Touch screen
 - Operating, 10-18
- Touch screen front, 8-5
 - set, 8-5
- Touch software, 9-6, 9-7
 - Maloperation, 9-7
 - set, 9-6
 - Special features, 9-7
- Trademark, 1-2
- Transport, 2-6
- Troubleshooting, 14-3
- Type of fixation, 4-7

U

- Update, 2-7
- Upper-case letter, 10-6
 - Toggling to lower-case letter, 10-6
- USB, 3-3, 8-13, 15-3

- Interface assignments, 17-9
- Interfaces, 17-2
 - Technical data, 15-3
- USB interface, 3-2, 10-3, 10-16
- USB mouse, 10-16
- USB peripheral, 8-13
- User password, 17-60

V

- Versions Menu
 - BIOS Setup, 17-64
- VGA, 3-3
- Virus protection, 9-10
- visualizing, 12-11
 - Memory expansion, 12-11

W

- Warranty, 2-4
- Watchdog
 - Monitoring function, 11-5
 - Monitoring times, 11-5
- Weight, 15-5, 15-6
- Windows 2000 Professional
 - Partitioning the hard disk, 12-30, 12-37
- Windows XP
 - Selecting the language, 9-16
- Windows XP Professional
 - Partitioning the hard disk, 12-30, 12-37

Siemens AG

Automation and Drives
Industrial Automation Systems
Postfach 4848
90437 NUERNBERG
Federal Republic of Germany

www.siemens.com/automation

ID: A5E00877780-01