



---

## Safety Guidelines

This manual contains notices intended to ensure personal safety, as well as to protect the products and connected equipment against damage. These notices are graded according to severity by the following texts:



---

### Danger

indicates that death or severe personal injury **will** result if proper precautions are not taken.

---



---

### Warning

indicates that death or severe personal injury **can** result if proper precautions are not taken.

---



---

### Caution

used with the safety alert symbol indicates a potentially hazardous situation which, if not avoided, may result in minor or moderate injury.

---

---

### Caution

used without the safety alert symbol indicates a potentially hazardous situation which, if not avoided, may result in property damage.

---

---

### Notice

indicates that unwanted events or status can occur if the relevant information is not observed.

---

## Operating safety and safety regulations

Detailed information on operating safety and the applicable safety regulations is provided in the "OP 77B" operating instructions.

## Voltage supply

---

### Warning

The OP 77B complies to Protection Class I in accordance with EN 61131-2 and EN 50178.

Ensure safe electrical insulation of the power supply. Only use mains power supply units which fulfill the standards for SELV and PELV.

When dimensioning the power supply, take a voltage drop in the connection cable into account!

---

## Operating Instructions (Compact) – for professionals

Important information on the OP 77B is summarized in these Operating Instructions (Compact).

## Operating Instructions

Detailed information on the OP 77B is provided in the "OP 77B" operating instructions.

## Migration

Information on migration of existing OP7 and C7-633 projects to WinCC flexible is provided in the "WinCC flexible Migration" operating instructions.

PDF files on this topic are also available in Internet under [http://www.ad.siemens.de/simatic/index\\_76.htm](http://www.ad.siemens.de/simatic/index_76.htm).

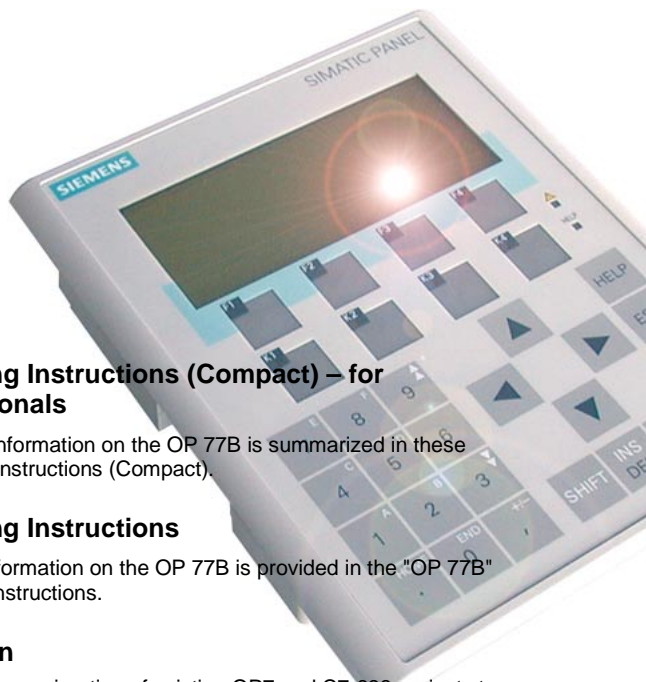

**Editor and Publisher**

A&D AS SM ID 5

**Printer**

A&D AS EWK

**Copyright Siemens AG 2004 All rights reserved**

The reproduction, transmission or use of this document or its contents is not permitted without express written authority. Offenders will be liable for damages. All rights, including rights created by patent grant or registration of a utility model or design, are reserved.

**Disclaimer of Liability**

We have checked the contents of this manual for agreement with the hardware and software described. Since deviations cannot be precluded entirely, we cannot guarantee full agreement. However, the data in this manual are reviewed regularly and any necessary corrections included in subsequent editions. Suggestions for improvement are welcomed.

# Contents

<b>1</b>	<b>Overview</b>	
1.1	HMI Device Design.....	1-1
1.2	Options.....	1-3
1.3	Miscellaneous .....	1-4
1.4	Scaled Drawings .....	1-4
1.5	Description of Interfaces.....	1-5
<b>2</b>	<b>Technical Data</b>	
<b>3</b>	<b>Installing the OP 77B</b>	
3.1	EMC Guidelines .....	3-1
3.2	Installation Position and Fixation .....	3-2
3.3	Producing the Installation Cut-Out.....	3-3
<b>4</b>	<b>Connecting the OP 77B</b>	
4.1	Connecting the Potential Equalization .....	4-2
4.2	Connecting the PLC .....	4-3
4.3	Connecting the Configuration Computer.....	4-6
4.4	Connecting Peripheral Equipment .....	4-7
4.5	Connecting the Power Supply .....	4-8

<b>5</b>	<b>Operating the OP 77B</b>	
5.1	Front Side Operating Elements and Indicators ...	5-1
5.2	Further Operating Elements .....	5-2
5.3	Operating the Project .....	5-7
5.4	Input Within a Project .....	5-10
5.4.1	Numeric values .....	5-10
5.4.2	Alphanumeric values.....	5-11
5.4.3	Entering numeric and alphanumeric characters.....	5-12
5.4.4	Correcting input .....	5-14
5.4.5	Entering symbolic values .....	5-16
5.4.6	Entering date and time .....	5-17
5.5	Calling Help on a Project.....	5-17
5.6	Logging On and Off.....	5-18
5.7	User Administration in a Project .....	5-19
5.7.1	Log on user.....	5-21
5.7.2	Setting up a user.....	5-22
5.7.3	Changing passwords .....	5-24
5.7.4	Deleting a user name.....	5-24
<b>6</b>	<b>Recipes and Alarms</b>	
6.1	Operating Recipes .....	6-1
6.2	Operating Alarms .....	6-8
<b>7</b>	<b>Index</b>	

# 1

## Overview

### 1.1 HMI Device Design

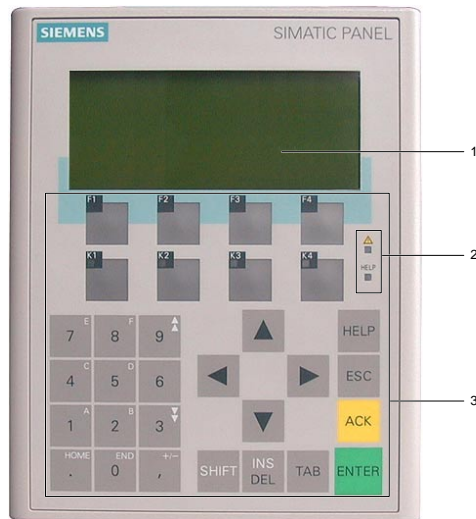

- 1 Display
- 2 LED display
- 3 Membrane keyboard

Figure 1-1 Front view

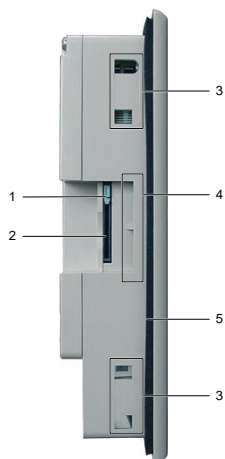

- 1 Memory card holder
- 2 Memory card slot for an MMC
- 3 Slot for wrench
- 4 Guides for the labeling strips
- 5 Rubber seal

Figure 1-2 Side view

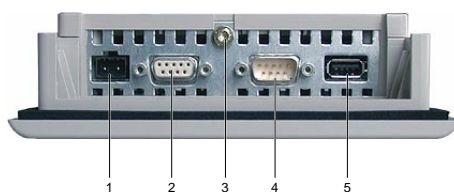

- 1 Connection for the power supply
- 2 RS 422/RS 485 interface (MPI/PROFIBUS DP-interface)
- 3 Ground connection
- 4 RS 232 interface (serial interface)
- 5 USB interface

Figure 1-3 Bottom view



## 1.2 Options

### Memory card

An MMC (Multi Media Card), tested and approved by Siemens AG can be used as an external storage medium. The memory card is an option and can be ordered separately.

---

**Notice**

The MMC of the SIMATIC S7 controller cannot be used.

---

### Accessory kit

Plug for the power supply (terminal block)	1 piece
Spring terminals for installing the HMI device	4 pieces
Supplement	1 piece

The Supplement is only applicable for the HMI device with the following identification on the rear:



## 1.3 Miscellaneous

### Labeling strips

Labeling strips are not supplied as accessories. If necessary, these can be produced using the template supplied. The template can be found on the installation computer after installing WinCC flexible and on the "WinCC flexible" installations CD under ...\\Documents\\slide77b.doc.

## 1.4 Scaled Drawings

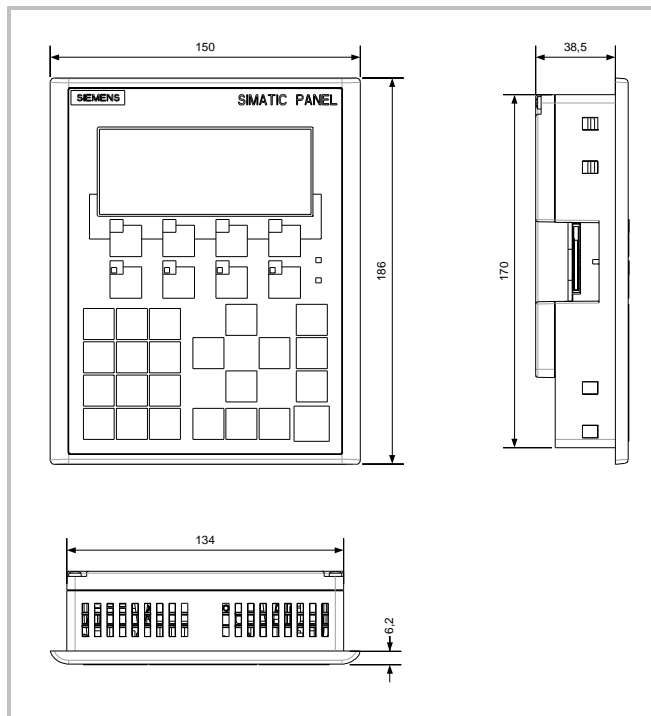

Figure 1-4 Main dimensions of the OP 77B

## 1.5 Description of Interfaces

### Power supply



Plug connector, 2-pin

Pin	Assignment
1	+24 V DC
2	GND

Figure 1–5 Pin assignment for power supply

### RS 422/RS 485 (IF 1B)

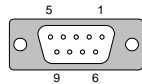

Sub-D socket, 9-pin,  
secured by screws

Pin	Assignment with RS 422	Assignment with RS 485
1	N. c.	N. c.
2	M	M
3	TxD+	LTG-B
4	RxD+	RTS-AS
5	GND, potential-free	GND, potential-free
6	DC +5 V, potential-free	DC +5 V, potential-free
7	DC 24 V in	DC 24 V in
8	TxD-	LTG-A
9	RxD-	RTS-AS

Figure 1–6 RS 422 and RS 485 interface pin assignments

### RS 232 (IF 1A)

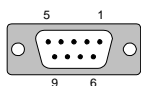

Sub-D plug, 9-pin, secured by screws

Pin	Assignment
1	DCD
2	RxD
3	TxD
4	DTR
5	GND
6	DSR
7	RTS
8	CTS
9	N. c.

Figure 1-7 RS 232 interface pin assignment

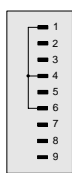

Figure 1-8 Pin switching

### USB



USB standard connector

Pin	Assignment
1	DC +5 V, max. 100 mA
2	USB-DN
3	USB-DP
4	GND

Figure 1-9 USB standard connector pin assignment

## 2

## Technical Data

### Housing

Degree of protection	
• Front panel	IP65, NEMA 4X/NEMA 12 indoor use only
• Rear panel	IP20
Weigh – without packing	
	Approx. 500 g

### Display

Type	STN
Screen area, active	102.38 x 40.94 mm
Resolution	160 x 64 pixels
Pixel size	0.62 x 0.62 mm
Colors, possible	Monochrome, yellow-green
Contrast control	Yes
Brightness, typical	20 cd/m <sup>2</sup>
Back-lighting – Half Brightness Life, typical	100,000 h

### Keyboard

Type	Membrane keyboard
System keys with dedicated functions	23
Softkeys	8
Configurable as softkeys	8
Labeling strips	2 for keys: F1 to F4 and K1 to K4
Keys with LED	4, keys K1 to K4

## Memory

Working memory	1 MByte
Memory card	MMC, optional

## Power supply

Rated voltage	24 V DC
Range, permissible	+18 V to +30 V
Transients, maximum permissible	35 V (500 msec)
Time between two transients, minimum	50 s
Power consumption	
• Typical	Approx. 200 mA
• Constant current, maximum	Approx. 300 mA
• Power on current surge $I^2t$	Approx. 0.5 A <sup>2</sup> s
• USB interface	Approx. 100 mA
Fuse, internal	Electronic

# 3

## Installing the OP 77B

### 3.1 EMC Guidelines

#### Electromagnetic compatibility

The HMI device fulfills the requirements stipulated in the law on EMC in Germany as well as the EMC guidelines of the European Union.

#### Installing HMI devices conform to EMC requirements

Preconditions for errorfree operation are a PLC design compliant with EMC requirements and the use of interferenceproof cables. The "guidelines for interference-free construction of PLCs" and the "PROFIBUS network" manual apply for the installation of the HMI device.

---

**Note**

The term "switching cabinet" subsequently used also relates to the installation cabinets, front panels and consoles.

---

## 3.2 Installation Position and Fixation

### Installation positions

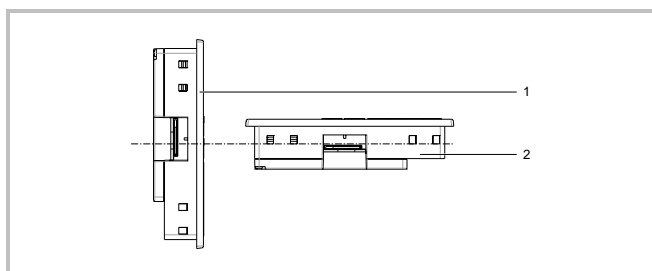

	Installation position	Max. permissible ambient temperature
1	vertical	50 °C
2	horizontal	40 °C

Figure 3-1 Permissible ambient temperatures without external ventilation

If the unit is installed horizontally and the permissible ambient temperature is exceeded, external ventilation is necessary. In general, ambient temperatures exceeding 50 °C are impermissible.

#### Caution

If the HMI device is used at a temperature exceeding the maximum permissible temperature without any external ventilation, the terms of warranty complying to UL 508 are annulled!



### Type of fixation

Spring terminals are provided for installation in a switching cabinet. Install them in the slots as illustrated in the figure below.



Figure 3-2 Installing the spring terminals

## 3.3 Producing the Installation Cut-Out



### Warning

#### Danger, high voltage

After opening the switching cabinet, parts become exposed which conduct voltage levels that could prove fatal on contact.

Switch off the power supply to the switching cabinet before opening it.

When selecting the installation cut-out, ensure that the installation surface around the installation cut-out is stable. If necessary, install reinforcements.

**Caution**

The degree of protection against water and dust can only be guaranteed when the following is maintained:

- Material thickness for the installation cut-out  
2 mm to 6 mm
- Deviation of the installation cut-out to the horizontal plane in respect of the overall dimensions of the HMI device:  
 $\leq 0.5$  mm
- Permissible surface roughness in the area of the installation seal:  
 $\leq 120$   $\mu\text{m}$  ( $R_z$  120)

An installation cut-out complying to the figure below is required:

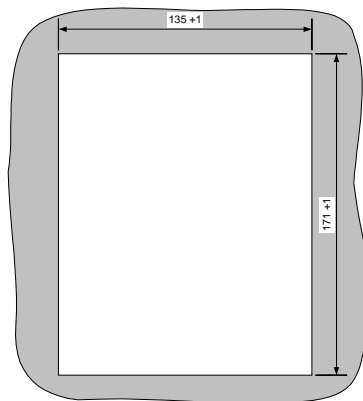

Figure 3-3 Installation cut-out

Ensure that the switching cabinet has enough space to allow a sufficient circulation of air.

# 4

## Connecting the OP 77B

### Conditions

- Installation of the HMI device in accordance with the specifications in the operating instructions

### Electrical connections

Connect the HMI device in the following sequence:

1. Potential equalization line
2. PLC
3. Configuration computer, if necessary
4. Peripheral equipment, if necessary
5. Power supply

---

#### Notice

##### Connection sequence

Please observe the sequence of HMI device connections. Failure to do so may result in damage to the HMI device.

When disconnecting the connections, ensure it is done in the reverse sequence.

---

### Connecting the cables

When connecting the cables, ensure that the contact pins are not bent. Secure the cable plug, if possible, with screws.

## 4.1 Connecting the Potential Equalization

### Connection configuration

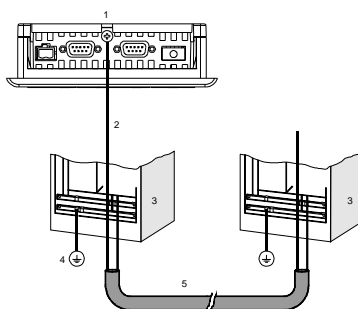

- |   |  |
|---|--|
| 1 | Grounding connection on the HMI device |
| 2 | Grounding cable                        |
| 3 | Switching cabinet                      |
| 4 | Grounding connection                   |
| 5 | Potential equalization line            |

Figure 4–1 Potential equalization line connection

#### Notice

##### Potential equalization line

Line shields are not suitable for potential equalization. Only use the potential equalization lines recommended – refer to Figure 4–1. Potential equalization lines, for example, must have a minimum cross-section of  $16 \text{ mm}^2$ . When setting up MPI and PROFIBUS DP networks, ensure cables with a sufficient cross-section are used otherwise the interface modules may be damaged or even destroyed.

## 4.2 Connecting the PLC

### Connection configuration

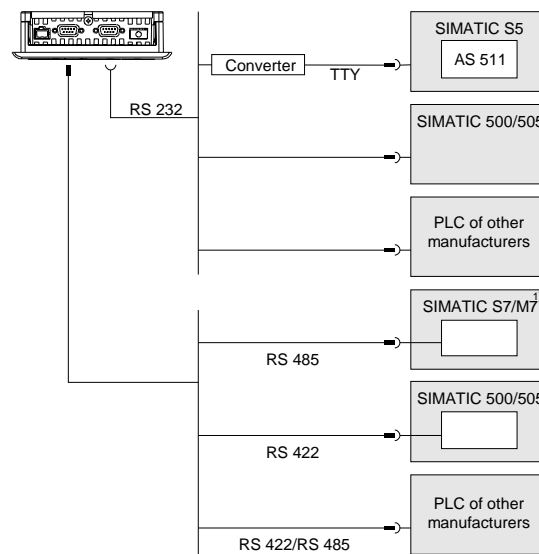

1 Use only the approved cables for connections to the SIMATIC S7.

Figure 4–2 Connecting the PLC

- Interfaces: Serial
- Interface description – refer to Chapter 1.5.
- Standard cables are available for the connection – refer to SIMATIC HMI Catalog ST 80

## Configuring the interface

The RS 422/RS 485 interface can be configured by changing the switch settings on the DIL switch. In this case, the RS 422 receive data and RTS signal are interchanged.

Normally, the RTS signal is not required by the PLC.

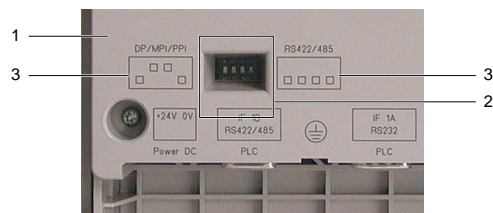

- |   |                                    |
|---|------------------------------------|
| 1 | Rear panel cover                   |
| 2 | DIL switch                         |
| 3 | Illustration of the switch setting |





Figure 4-3 Position of the DIL switch

### Note

Pay attention to the DIL switch settings on the rear of the HMI device depicted in the diagrams – also refer to Table 4-1.

The following table describes the DIL switch settings according to the communication to be selected. The switch settings relate to Figure 4-3.

Table 4-1 DIL switch setting positions

Communication	Switch settings
 <p>MPI/PP1 Standard cable</p>	<p>4 3 2 1</p> <p><input type="checkbox"/> <input type="checkbox"/> <input type="checkbox"/> <input type="checkbox"/> ON</p> <p>No RTS on connector</p>
 <p>RS 422</p>	<p>4 3 2 1</p> <p><input type="checkbox"/> <input type="checkbox"/> <input checked="" type="checkbox"/> <input type="checkbox"/> ON</p>
 <p>PROFIBUS-DP/MPI</p>	<p>4 3 2 1</p> <p><input checked="" type="checkbox"/> <input checked="" type="checkbox"/> <input checked="" type="checkbox"/> <input type="checkbox"/> ON</p> <p>No RTS on connector</p> <p>4 3 2 1</p> <p><input checked="" type="checkbox"/> <input checked="" type="checkbox"/> <input checked="" type="checkbox"/> <input type="checkbox"/> ON</p> <p>RTS on Pin 9 (as programming unit)</p> <p>4 3 2 1</p> <p><input checked="" type="checkbox"/> <input checked="" type="checkbox"/> <input type="checkbox"/> <input type="checkbox"/> ON</p> <p>RTS on Pin 4</p>
<p>Switch</p> 	<p>4 3 2 1</p> <p><input checked="" type="checkbox"/> <input checked="" type="checkbox"/> <input checked="" type="checkbox"/> <input checked="" type="checkbox"/> ON</p> <p>State on delivery</p>

Connecting the OP 77B

### 4.3 Connecting the Configuration Computer

#### Connection configuration

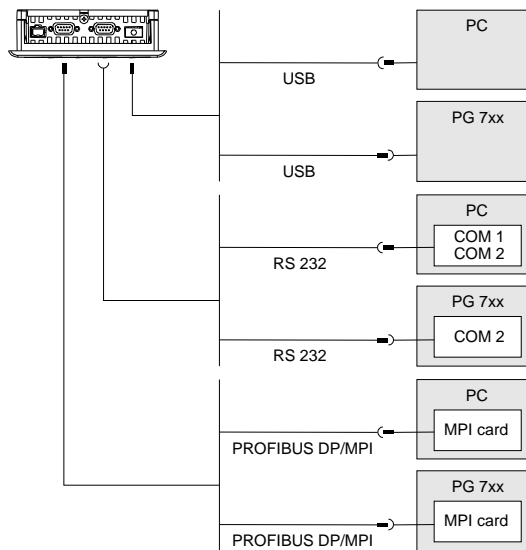

Figure 4-4 Connecting the configuration computer

- Interfaces: serial or USB
- Interface description – refer to Chapter 1.5.

Applies for the USB interface:

HMI device and programming unit are master.

Therefore, a host-to-host cable is required for the USB interface.



## 4.4 Connecting Peripheral Equipment

### Connection configuration

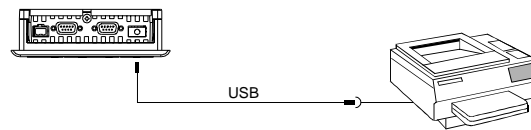

Figure 4-5 Connecting peripheral equipment

- Interfaces: USB
- Interface description – refer to Chapter 1.5.

---

#### Notice

##### Nominal load of the interface

The load capacity of the USB connection is limited to 100 mA. Avoid applying higher loads. Otherwise, functional faults can occur on the peripheral equipment connected.

---

The following peripheral equipment can be connected:

- Printer

---

#### Note

##### Documentation on peripheral equipment

Also observe the documentation supplied with the printer when connecting it.

---

## 4.5 Connecting the Power Supply

### Connection configuration



Figure 4–6 Connecting the power supply

The associated terminal block is contained in the accessories kit and designed for cables with a maximum cross-section of 1.5 mm<sup>2</sup>.

### Connecting the terminal block

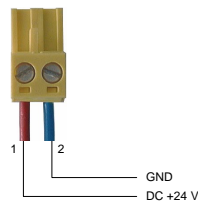

Figure 4–7 Connecting the terminal block

Connect the terminal lock to the power supply lines as illustrated in Figure 4–7. Ensure that the lines are connected properly and not to the wrong terminals.

### Reverse battery protection

The HMI device is equipped with reverse battery protection.

## Power supply

### Caution

Ensure safe electrical insulation of the power supply. Use only power supply units complying with IEC 364-4-41 or HD 384.04.41 (VDE 0100, Part 410).

Only use mains apparatus which complies to SELV (Safety Extra Low Voltage) and PELV (Protective Extra Low Voltage) standards.

The supply voltage must be within the specified voltage range. Voltages outside this range can cause HMI device malfunctions.

The requirements of the voltage supply are set out in Chapter 1.5.

## Switching on the HMI device

Proceed as follows:

1. Connecting the terminal block to the HMI device.
2. Switch on the power supply to the HMI device.

The following window appears:

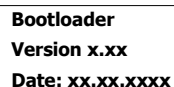

```
Bootloader
Version x.xx
Date: xx.xx.xxxx
```

Figure 4–8 Bootloader

If the HMI device does not run-up, it is possible that the lines on the terminal block have been swapped over. Swap the connected lines back.

After loading the operating system, the HMI device automatically switches to Transfer mode and the *Transfer* dialog opens:

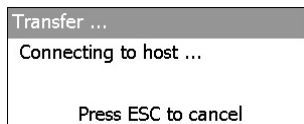

Figure 4–9 *Transfer* dialog

---

**Note**

When the HMI device is restarted, it is possible that a project already exists on the HMI device; in which case Transfer mode is not called in but the project is started. Exit from the project. The Loader then reappears.

---

3. Press 

After canceling, the Loader appears:

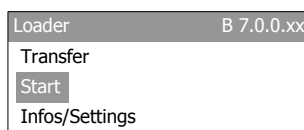







Figure 4–10 Loader

4. Switching off the power supply to the HMI device.

## Keys for navigation in the Loader

Table 4-2 Overview of keys available for use

Key	Effect of pressing
 or 	Move to the next menu item.
 or 	Move to the previous menu item.
	The menu item or associated submenu is called in.
	Cancel the entry and return to the menu item one level above.

**Note**

Entries in the dialog boxes are possible using the cursor keys – numeric values, too, using the numeric keypad.

Other keys without functions are available in the Loader.



# 5

## Operating the OP 77B

### 5.1 Front Side Operating Elements and Indicators

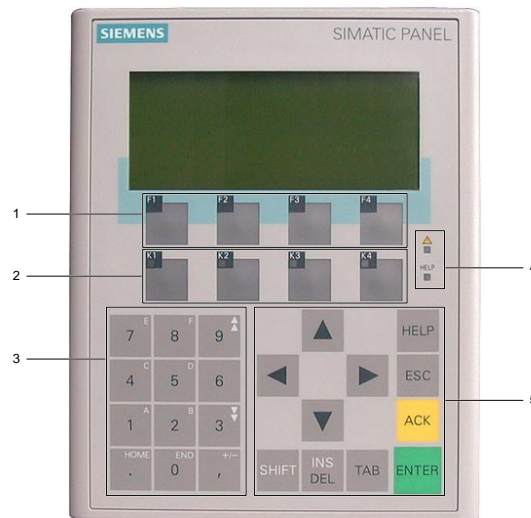

- |   |                            |
|---|----------------------------|
| 1 | Softkeys without LED       |
| 2 | Softkeys with LED          |
| 3 | System keys – digit keypad |
| 4 | LED display                |
| 5 | System keys – control keys |

Figure 5-1 Front side operating elements and indicators

Operating the OP 77B

The standard input unit for the OP 77B is the keyboard. This is basically composed of two key groups:

- Softkeys  
F1 to F4 and K1 to K4  
The function executed by each softkey is defined specifically for a project during the configuration phase; the softkey have no function in the Loader.
- System keys  
Digit keypad and control keys

---

**Notice****Keyboard damage**

Heavy-handed operation of the keys with a hard, pointed or sharp object leads to a considerable reduction in their service life and even to their complete failure.

Only use your fingers to operate the HMI device keys.

---

## 5.2 Further Operating Elements

When an HMI device is installed, further operating elements can be accessed by opening the switching cabinet.



---

**Danger****Danger, high voltage**

After opening the switching cabinet, parts become exposed which conduct voltage levels that could prove fatal on contact.

Switch off the power supply to the switching cabinet before opening it.

---



Other operating elements include:

- Ejection button on memory card holder; refer to Figure 5-2
- Guides for the labeling strips; refer to Figure 1-2
- DIL switches for the RS 422/RS 485 switch; refer to Figure 4-3

## Using memory cards

---

### Notice

#### Data loss

If a prompt for formatting appears when using a memory card for the first time on the HMI device, make a backup copy of the data on the memory card on a PC beforehand.

---

Proceed as follows to prevent loss of data:

1. Cancel the formatting process by pressing ESC
2. Data which must not be lost should be saved on a PC
3. Format the memory card on the HMI device
4. Transfer the data saved on the PC to the memory card

Then transfer the backed up data from the memory card to the HMI device.

## Ejecting the memory card

When the memory card is installed correctly in the memory card slot, the memory card holder is latched in behind the memory card.

Do not plug the memory card in or unplug it during data access when making a data backup or transferring a recipe. Otherwise, the memory card can be inserted and removed during operation.

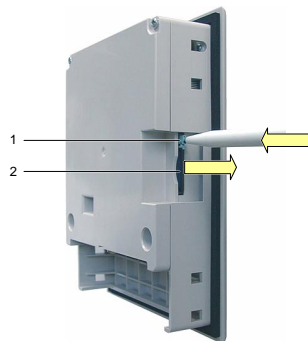

- |   |            |
|---|------------|
| 1 | Eject knob |
| 2 | MMC        |

Figure 5-2 Ejecting the memory card

On pressing the Eject knob, the memory card is released from the memory card slot.

---

### Notice

Do not press the knob abruptly. This could damage the ejection mechanism.

---

Store the memory for safekeeping well protected.

## Labeling the softkey

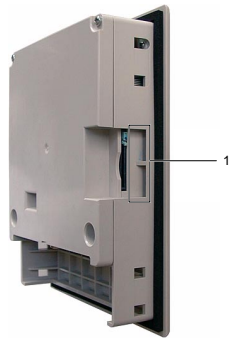

1 Guides for the labeling strips

Figure 5-3 Labeling of the softkey

The labeling strips can also be inserted when the HMI device has been installed.

Softkeys which are not screen dependent can be provided with labeling strips (also refer to Figure 5-6).

## Printing the labeling strips

The template can be found on the installation computer after installing WinCC flexible and on the "WinCC flexible" installation CD under ...Documents\slide77b.doc.

The file can be edited using the MS Office programs MS Word or Wordpad.

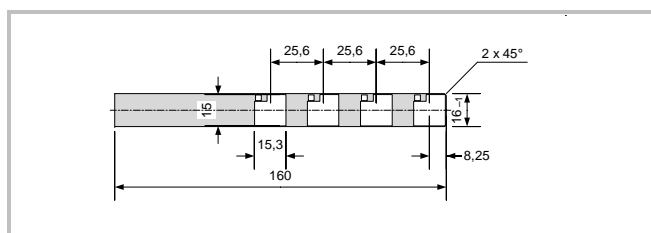

Figure 5-4 Labeling strip dimensions

Where possible, print the labeling strips on transparent foil. This means that the LEDs on the softkeys remain visible.

1. Edit and print templates
2. Cut out labeling strips  
Ensure that the corners are cut according to Figure 5-4. This simplifies sliding it into the guide.

---

**Danger****Danger, high voltage**

After opening the switching cabinet, parts become exposed which conduct voltage levels that could prove fatal on contact.

Switch off the power supply to the switching cabinet before opening it.

---

3. Remove the existing labeling strips
4. Slide the labeling strips in the guide

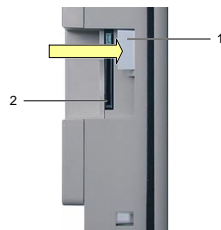

- |   |                 |
|---|-----------------|
| 1 | Labeling strips |
| 2 | MMC             |

Figure 5-5 Insert the labeling strips

## 5.3 Operating the Project

### Softkeys with global function assignment

A softkey with global function assignment always triggers the same action on the HMI device or PLC regardless of the screen currently open. These actions include:

- Calling in a screen
- Printing the screen displayed

Within a screen, a softkey can only have one function assigned – either global or local. In the case of local and global functions, the local function has priority.

### Softkeys with local function assignment

A softkey with a local function assignment relates to a specific screen and, thus, is only effective in the active screen.

The function of a softkey can vary from screen to screen.

The two-row softkeys are particularly suitable for implementing binary states and machine functions, as illustrated in the following screen.

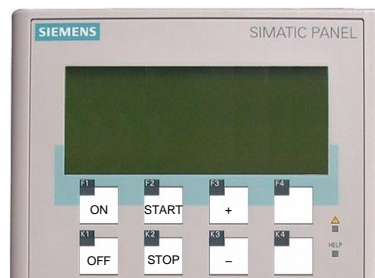























Figure 5–6 Example of two row, labeled keys

### System keys











Table 5-1 Overview of control keys

Key	Effect of pressing
 , 	The cursor keys have a repeat function. In the case of I/O fields, selects the next field in horizontal direction.
 , 	In the case of I/O fields, selects the next field in vertical direction.
	The following field is selected in the sequence defined in the project (Tab Order).
	The second function of another key is released for use.
 + 	When used with the cursor keys, scroll in the selection fields; refer to Chapter 5.4.3 and 5.4.5.
 + 	
 + 	The Tab Order is reversed
	In character "String" input fields, the character at the current cursor position is deleted.  All the following characters move one position to the left.
	Calls in a window containing operator notes on the selected object. Condition: Operator notes are only available on the selected object when the  LED lights up.  Pressing  enables toggling between operator notes for a screen and an object; toggling for an I/O field for example.
	<ul style="list-style-type: none"> <li>Undo An entry can be undone by pressing this key before the  key is pressed to confirm the input.</li> <li>Close the System Event window, if configured</li> <li>Cancel the display of an operator note to return to the previous display.</li> </ul>
	Acknowledges the alarm current displayed or marked, or all alarms in an acknowledgment group, depending on the configuration; refer to Chapter 6.2

Key	Effect of pressing
	<ul style="list-style-type: none"> <li>The input is confirmed and applied.</li> </ul>
	<ul style="list-style-type: none"> <li>Initiates input via  and </li> </ul>

## Navigation in lists

Table 5-2 Keys for navigation in lists

Key	Effect of pressing
 or 	Selects the previous or next list item.
 + 	Scrolls one page forward or back to other list entries
 + 	
 + 	Marks the first or last entry in a list
 + 	

## 5.4 Input Within a Project

### General procedure

Values are entered in the project input fields. They are transferred from there to the PLC.

Proceed as follows:

1. Open the required screen.
2. Select the required input field from the screen.  
Enter values of the following type in the input field according to the configuration:
  - Numeric
  - Alphanumeric
  - Symbolic
  - Date/Time
3. Enter value

Incorrect input can be canceled by pressing .  
The original value is then automatically restored.

4. Confirm input with .

### 5.4.1 Numeric values

#### Entering numeric values

Numeric values are entered character by character using the system keyboard. If a field already contains a value, it is fully deleted from the field after entering the first character of the new value using the numeric keypad. The value can also be modified character by character by pressing ENTER.



## Display formats

Values can be entered in numeric input fields using the following display formats:

- Decimal
- Hexadecimal
- Binary

The input can be aligned to the left or right, depending on the configuration.

## Limit value test

Limit values can be configured for tags. If the value entered exceeds a configured limit value (e.g. 55 with a limit value of 50), a system event is automatically displayed in cases where an alarm window has been configured. The value entered is not accepted and the original value reappears.

## Decimal places

If a numeric input field is configured with a specific number of decimal places, additional decimal places are ignored after confirmation or too few decimal places are filled with "0".















### 5.4.2 Alphanumeric values

Alphanumeric values – digits and letters – are entered character by character using the system keyboard. If a field already contains a value, it is fully deleted from the field after entering the first character of the new value using the numeric keypad. The value can also be modified character by character by pressing ENTER.

If characters are required which are not available on the keypad, select them using the character set on the extended keyboard. The extended character set is available in "String" format fields.

### 5.4.3 Entering numeric and alphanumeric characters

Table 5-3 Overview of keys for use for entering characters

Key	Effect of pressing
 to 	Enter the digits 0 to 9.
 , 	Enter a comma or stop.
 + 	The sign of a numeric value is changed Press  to toggle between the two signs.
 +  to  + 	Letters A to F can be entered
 	The characters in an extended character set are called in successively All 255 character are displayed in succession.
	The input is valid.
	The input is deleted. The original value becomes valid again.

### Example of alphanumeric input using cursor keys and numeric keypad

To enter "OP 77B", activate the selection field. If the cursor keys are used for input, press them until the required character appears. The following keyboard input is necessary:

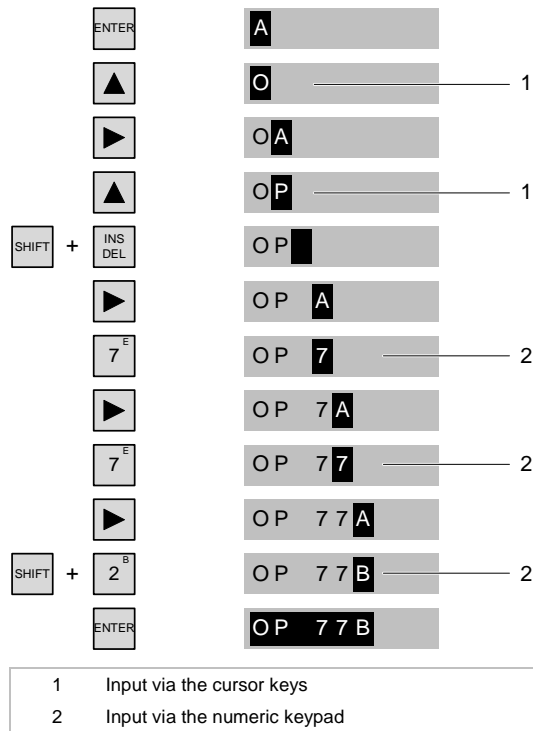

Figure 5-7 Example of alphanumeric input using cursor keys and numeric keypad





Operating the OP 77B

## 5.4.4 Correcting input

### Correcting input using the cursor keys



#### Replacing an incorrect character

Proceed as follows:

1. Press 
2. Position the cursor at the character to be changed.
3. Press  or  until the required character appears.
4. Press 

#### Deleting a character

Proceed as follows:

1. Press 
2. Position the cursor at the character to be deleted.
3. Press 



The marked character is deleted. The remaining characters to the right of the cursor shift one position to the left.

Valid for writing aligned to the right:

The marked character is deleted. The remaining characters to the left of the cursor shift one position to the right.

**Entering a space**

Proceed as follows:

1. Press 
2. Move the cursor to the position where a character is to be entered.
3. Press  +  – a space is entered.

The remaining characters to the right of the cursor shift one position to the right.

Valid for writing aligned to the right:

The remaining characters from the cursor shift one position to the left.

**Correcting input using the numeric keypad****Replacing an incorrect character**

1. Press 
2. Position the cursor at the character to be changed.
3. Enter the correct character via the numeric keypad





**One character too many or too few**

Corrections are made as described in Section "Correcting input using the cursor keys".



### 5.4.5 Entering symbolic values

The work involves accepting text from a symbolic I/O field. Proceed as follows:



1. Select a symbolic I/O field
2. Activate the selection field.

Key	Effect of pressing
 or  +   + 	The selection field is activated containing the symbolic input configured for it.

3. Select text.

Key	Effect of pressing
 , 	Text is scrolled in a single line list until the text searched for is found.

4. Accept or cancel the input

Key	Effect of pressing
	The text selected becomes valid. The symbolic I/O field is deactivated.
	The original text becomes valid again. The symbolic I/O field is deactivated.

### 5.4.6 Entering date and time

To enter the date and time, use the keys according to the section "Entering numeric and alphanumeric characters".

---

**Note**

When entering the date and time, please note that the format is dependent on the language set.

---

Use the keys as described in Chapter 5.4.3 to enter the date and time.

## 5.5 Calling Help on a Project

Operator notes can be created for the following objects during configurations with WinCC flexible ES:

- Alarms
- Screens
- I/O field
- Recipes and recipe elements

Operator notes can be configured in several languages.

The availability of an operator note is indicated by the HELP

LED when lit up. The configured operator notes

can be displayed on the HMI device by pressing .

## 5.6 Logging On and Off

### General information

Standard groups in the security system are:

- Administrator
- User

Other groups can be configured. Each group is assigned certain user rights. Each user is assigned to one of these groups, i.e. users within a group have the same operating rights. Each user is assigned a password.

### Login dialog

When a user calls a function which is protected and has not been assigned the necessary user rights, the *Logon* dialog appears.

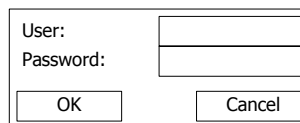

The image shows a simple dialog box with a rectangular border. On the left side, there are two labels: 'User:' and 'Password:'. To the right of each label is a rectangular input field. Below the input fields, there are two buttons: 'OK' on the left and 'Cancel' on the right.

Figure 5–8 Example of a *Logon* dialog

1. Enter the user name and password – refer to Chapter 5.4.3 for the keys.

---

#### Note

Characters entered for the password are always represented by "\*". Characters entered via the cursor keys remain visible until another character is entered or the input is confirmed with the ENTER.

---



2. Select OK

3. Press  to confirm

If the user has the necessary user rights for a selected operating element, it can be operated. Otherwise, an alarm appears indicating the user does not have the necessary rights.

---

**Note**

In the case of an operating element assigned operating rights, a log on is necessary. This is obsolete, however, on exceeding the logoff time – refer to Figure 5-13.

---

## 5.7 User Administration in a Project

There are three groups which can manage the users and their assigned entries:

- the administrator  
During configuration, the administrator is assigned unlimited user rights.
- the operator (user)
- the user with unrestricted user rights.

These groups of people result from the assignment of user rights during configuration.

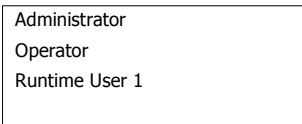

Administrator  
Operator  
Runtime User 1

Figure 5-9 Example of a user display

In this case, as indicated in the example in Figure 5-9, the administrator and two users are shown. The administrator may change his own entries and those of the other users:

- User name
- Password
- Group assignment
- Log off time

In addition, further users can be set up. The empty bottom line is available for the setup.

- If a user cannot log on as "Administrator" but only as a user, only that entry is displayed, e.g. "Operator".

In this case, no unrestricted user rights have been assigned.

Only the following entries can then be changed for that user











- Password and
- Logoff time.

- However, it is possible for a user to modify the entry of another user. A condition for this is that the user rights include the user rights of the other users.

Entries which can be modified include:

- User name
- Password
- Group assignment
- Log off time

Table 5-4 Keys for navigation in lists

Key	Effect of pressing
 , 	Selects the previous or next user.
 + 	Scrolls one page up or down to other users.
 + 	
 + 	Selects the first or last user.
 + 	

### Limit values for user, password and user displays

	Characters
Length of user name, maximum	40
Length of password, minimum	3
Length of password, maximum	24
Entry in the user display, maximum	50

### 5.7.1 Log on user

Proceed as follows:

1. Select the empty line in the dialog – refer to Figure 5–9
2. Press ENTER

#### Note

The following *Logon* dialog only appears when the user has still not been logged on as a user. The dialog also appears when the user logs on as *Administrator* without the necessary user rights in order to create a new user.

The *Logon* dialog opens.

3. Enter the user and password.
4. Confirm with OK  
The dialogs necessary to set up a user then appear.

After having logged on, you can carry out the following according to your user rights:

- Change the password
- Create a user

### 5.7.2 Setting up a user

The following dialogs appear after entering the user and password:

A dialog box with a rectangular border. On the left side, the text "User:" is followed by a small vertical line and a rectangular input field. Below the input field, there are two buttons: "OK" on the left and "Cancel" on the right.

Figure 5-10 Example of a User dialog

Proceed as follows:

1. Enter a user
2. Confirm with OK  
The following dialog appears:

A dialog box with a rectangular border. On the left side, the text "Password:" is followed by a small vertical line and a rectangular input field. Below the input field, there are two buttons: "OK" on the left and "Cancel" on the right.

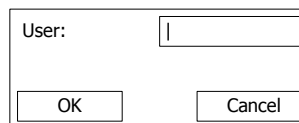
Figure 5-11 Example of a Password dialog

---

#### Note

The password is only legible once in plain text – when it is assigned in the *Password* dialog.

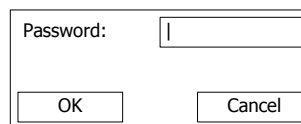
On entering a password at a later date, the characters entered are represented by \*.

---

3. Enter the password

## 4. Confirm with OK

The following dialog appears:

Figure 5-12 Example of a Group dialog

## 5. From the list of available groups, select the one containing the user rights to be assigned to the new user.







Make the selection using  +  or  or using  and then  or .

Figure 5-13 Example of a Logoff Time dialog

The logoff time is defined in minutes. 5 minutes are entered as the default value.

## 6. Select the value depending on the respective operating situation.

## 7. Confirm with OK

The user display appears containing the new user, refer to Figure 5-9.

### 5.7.3 Changing passwords

The following dialogs appear after entering the user and password:

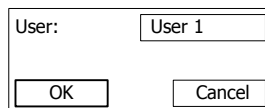

Figure 5-14 Example of a Password dialog

Proceed as follows:

1. Enter a user
2. Confirm with OK

The following dialog appears:

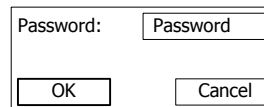

Figure 5-15 Example of a Password dialog

3. Enter the password
4. Confirm with OK

Confirm the two subsequent dialogs. The new password becomes valid.

### 5.7.4 Deleting a user name

When a user is deleted, the password is deleted from the User display. A condition for deleting users is the assignment of administrator rights.

There are two methods of deleting a user:

- Select the user name in the User display and press



- Delete all the characters in the user name input dialog and confirm by clicking OK.

# 6

## Recipes and Alarms

### 6.1 Operating Recipes

#### Terminology

**Recipe**

A recipe is comprised of several tags which define the data structure of a data record.

**Data record**

A data record contains the values of a recipe.

**Recipe entry**

A recipe element consists of an entry name and a value. The names, assigned to the tags, are referred to as element names.

**Single recipe views**

The Recipe view is a configurable object in the recipes, data records and recipe elements displayed in lists. These are described below.

### Recipe list

The recipes configured are displayed as a recipe list. A recipe list can appear as follows, for example:

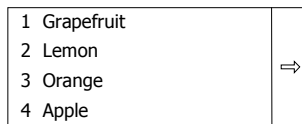







Figure 6-1 Example of a recipe list

Table 6-1 Overview of keys available

Key	Effect of pressing
 + 	Creates a new data record.
	Opens the data record list of the selected recipe.
	Calls in a window containing operator notes on the selected object – refer to Table 5-1.
	Opens the menu

Further keys used for navigation are explained in Section "Navigation in lists". This also applies to operating in recipes.







## Data record list – Data records of a recipe

1 Juice
2 Drink
3 Nectar

Figure 6-2 Example of a data record list

Table 6-2 Overview of keys used in data record lists

Key	Effect of pressing
 	Creates a new data record.
	Opens the entry list of the selected data record.
	The recipe list is displayed again.

### Note

When the first data record has been selected and  is pressed, the associated recipe name is displayed.

### Element list – data record values

The element list can be used to edit data record values.

l Orange	90		1
l Water	10		2
kg Sugar	1.5	⇒	3
g Aroma	200		

1	Data record
2	Menu
3	Element name

Figure 6-3 Example of an element list

The sequence of columns for element names and values can be configured.

Table 6-3 Overview of keys available for use

Key	Effect of pressing
ESC	The data record list is displayed again.
HELP	Calls in a window containing operator notes on the selected object – refer to Table 5-1.

**Note**

When the first element has been selected and  is pressed, the associated data record and recipe name is displayed.

Proceed as follows to edit a value:

1. Select element name  
The entries possible are dependent on the tag type. If a text list has been configured in a recipe element, symbolic values can also be entered.
2. Enter value
3. Apply the entry or cancel it

## Menu

A menu is available for quick access to the permitted operating procedures in recipes, data records and element lists.

<i>Menu button</i>	<i>Effect of pressing</i>
⇨	Call in the menu

Alternatively to using ⇨, the menu can be called in with



The menu items which can be configured can be determined from Table 6-4.

## Configurable menu items in the Recipe view

The following table indicates which menu items are available in the three lists. Some menu items in the following table can also be called in via the system keys.

Table 6-4 Overview of configurable menu items

Menu item	System key	Recipe list	Data record list	Entry list
Add data record	SHIFT + INS DEL	Yes	Yes	–
Save data record		–	–	Yes
Delete data record	INS DEL	–	Yes	–
Write data record in PLC		–	–	Yes
Read data record from PLC		–	–	Yes
Data record, save as		–	Yes	Yes
Data record, rename		–	Yes	Yes
Display operator notes	HELP	Yes	Yes	Yes
Open list	ENTER	Yes	Yes	–
Open previous list	ESC	–	Yes	Yes

The menu can appear as follows, for example:

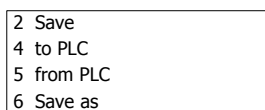





Figure 6-4 Example of a menu with menu items configured for entry lists

Each of these menu items can also be called in by entering the assigned number or by marking it with the cursor and pressing ENTER.

Table 6-5 Overview of keys for use in a menu for a Recipe view

Key	Effect of pressing
 to 	Calls in the assigned menu item.
	Triggers the menu item selected with the cursor.
	Displays the previously selected list.

### Example

Using the *Save Data Record* menu item – refer to Figure 6–4.

Proceed as follows:

#### With cursor key input

1. Select *Save Data Record* with the cursor key.
2. Confirm the selection with ENTER.  
The data record is saved and the entry list reappears.

#### With numeric input

1. Enter "2".  
The data record is saved and the entry list reappears.

## 6.2 Operating Alarms

### Alarm classes

The alarm classes can exist in a project:

- User-defined alarms  
A user-defined alarm can be assigned to one of the following alarm classes:
  - Fault  
Alarms in this category must always be acknowledged.
  - Operation
  - User-defined alarm classes  
The properties of this alarm class are defined during configuration.
- System events  
A system event is assigned to the "System" event category.

The related alarms consist of static text. They can also contain tags. It is possible to configure an alarm text to flash.

A maximum of 80 characters per alarm are possible.

### "Fault" alarm class

The occurrence of an alarm of the alarm class "Fault" is indicated by the flashing "alarm indicator" LED:



Figure 6-5 "Alarm indicator" LED

The "alarm indicator" LED

- is off when no alarms of the "Fault" alarm class are queued,
- flashes when an alarm of the "Fault" alarm class has been received but not acknowledged and
- only lights up if acknowledged alarms of the "Fault" alarm class are present.

## Alarm view

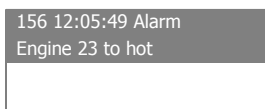

Figure 6-6 Alarm view for "Fault" alarm class

It is possible to configure:

- The number of lines per alarm.
- Number of visible lines

Table 6-6 Overview of keys used in Alarm views

Key	Effect of pressing
ACK	Acknowledges the alarms which have arrived.
HELP	Calls in the operator notes on the selected alarm.

Further keys for navigation purposes are explained in Table 5-1.

The keys displayed in the table are valid for all alarm classes.

## Edit alarm

Pressing  triggers the function assigned to the "Edit" event in respect of a selected alarm.





## 7

## Index

**A**

- Accessory kit 1–3
- Alarm class
  - Fault 6–8
- Alarm classes 6–8
  - User-defined 6–8
- Alarm view 6–9
- Alarms 6–1
  - User-defined 6–8
- Alphanumeric input
  - Via the cursor keys 5–14
  - Via the numeric keypad 5–14

**B**

- Bottom view 1–2

**C**

- Cable cross-section 4–8
- Configuring
  - Interface 4–4
- Configuring the interface 4–4
- Connecting
  - Configuration computer 4–6
    - OP 77B 4–1
    - Periphery 4–7
    - PLC 4–3
    - Potential equalization line 4–2
    - Power supply 4–8
    - Terminal block 4–8
  - Connecting peripheral equipment 4–7

- Connecting the configuration computer 4–6
- Connecting the PLC 4–3
- Connecting the potential equalization 4–2
- Connecting the terminal block 4–8
- Connection configuration
  - Configuration computer 4–6
  - Periphery 4–7
  - PLC 4–3
  - Potential equalization line 4–2
  - Power supply 4–8
- Connection sequence 4–1
- Connections, electrical 4–1
- Control keys 5–9
- Correcting
  - Input 5–15
- Cross-section
  - connection cables 4–8

**D**

- Data record list 6–3
- Date 5–18
- Decimal places 5–12
- Deleting a user name 5–25
- DIL switch 4–5
- Display 2–1
- Display formats 5–12

**E**

- Edit
  - Alarm 6–9
- Edit alarm 6–9
- Element list 6–4
- EMC Guidelines 3–1
- Entering
  - Alphanumeric characters 5–13
  - Date and time 5–18
  - Numeric characters 5–13
  - Numeric values 5–11
  - Symbolic values 5–17
- Example
  - Alphanumeric input via the cursor keys 5–14
  - Alphanumeric input via the numeric keypad 5–14

**F**

- Front view 1–1

**G**

- Guidelines
  - EMC 3–1

**H**

- Help on a project 5–18
- Housing 2–1

**I**

- IF 1A 1–6
- IF 1B 1–5
- Indicators 5–1
- Input
  - Correcting 5–15
- Input in a project 5–11
- Installation
  - OP 77B 3–1
- Installation cut-out 3–3
- Installation positions 3–2
- Interfaces 1–5

**K**

- Keyboard 2–1

**L**

- Labeling 5–6
- Labeling strips 1–4, 5–6
- Limit value test 5–12
- Limit values
  - For users, passwords, user displays 5–22
- Log off 5–19
- Log on 5–19
  - User 5–22
- Login dialog 5–19

**M**

- Memory 2–2
- Memory card 1–3
  - Eject 5–5
  - Using 5–4
- Menu 6–5
- Menu items
  - Configurable 6–5
- Miscellaneous 1–4

**N**

- Navigation
  - Loader menu 4–11
- Navigation in lists 5–10

**O**

- OP 77B
  - Connecting 4–1
  - Installation 3–1
  - Operating 5–1
- Operating
  - Alarms 6–8
  - OP 77B 5–1
  - Project 5–8
  - Recipes 6–1
- Operating elements
  - Front side 5–1
  - Other 5–3
- Operating recipes 6–1
- Operating system

Load 4–10  
Options 1–3  
Overview 1–1

**P**

Power supply 1–5, 2–2  
Connecting 4–8  
print  
Labeling strips 5–6  
Project  
Help 5–18  
Input 5–11  
Operating 5–8  
User administration  
5–20

**R**

Recipe list 6–2  
Recipe views  
Menu 6–5  
Recipes 6–1  
Reverse battery protection  
4–8  
RS 232 1–6  
RS 422 1–5  
RS 485 1–5

**S**

Scaled drawings 1–4

Side view 1–2  
Softkeys 2–1, 5–3, 5–8  
global 5–8  
labeling 5–6  
local 5–8  
Switch settings 4–5  
Switching on 4–9, 4–10  
System keys 2–1, 5–3

**T**

Technical data 2–1  
Terminology  
Recipe views 6–1  
Time 5–18  
Type of fixation 3–3

**U**

USB 1–6  
User  
Log on 5–22  
User administration 5–20

**V**

Values  
alphanumeric 5–12  
numeric 5–11  
Symbolic 5–17

