

SIEMENS

SIMATIC

Control systems C7-636

Manual



The following supplement is part of this documentation:

No.	Designation	Drawing number	Edition
1	Product information	A5E00861679-01	07/2006

Preface, Table of contents

Guide through the document
landscape

1

Product overview

2

Installation and wiring

3

Special features of the
C7-636

4

Maintenance

5

Technical data

6

Index

This manual is a constituent part of the documentation
package with the order number:
6ES7636-1EA00-8BA0

This manual has the order number:
6ES7636-1AA00-8BA0

Edition 12/2004
A5E00270832-02

Safety Guidelines

This manual contains notices you have to observe in order to ensure your personal safety, as well as to prevent damage to property. The notices referring to your personal safety are highlighted in the manual by a safety alert symbol, notices referring to property damage only have no safety alert symbol. These notices shown below are graded according to the degree of danger.



Danger

indicates that death or severe personal injury **will** result if proper precautions are not taken.



Warning

indicates that death or severe personal injury **may** result if proper precautions are not taken.



Caution

with a safety alert symbol, indicates that minor personal injury can result if proper precautions are not taken.

Caution

without a safety alert symbol, indicates that property damage can result if proper precautions are not taken.

Attention

indicates that an unintended result or situation can occur if the corresponding information is not taken into account.

If more than one degree of danger is present, the warning notice representing the highest degree of danger will be used. A notice warning of injury to persons with a safety alert symbol may also include a warning relating to property damage.

Qualified Personnel

The device/system may only be set up and used in conjunction with this documentation. Commissioning and operation of a device/system may only be performed by **qualified personnel**. Within the context of the safety notes in this documentation qualified persons are defined as persons who are authorized to commission, ground and label devices, systems and circuits in accordance with established safety practices and standards.

Prescribed Usage

Note the following:



Warning

This device may only be used for the applications described in the catalog or the technical description and only in connection with devices or components from other manufacturers which have been approved or recommended by Siemens. Correct, reliable operation of the product requires proper transport, storage, positioning and assembly as well as careful operation and maintenance.

Trademarks

All names identified by ® are registered trademarks of the Siemens AG. The remaining trademarks in this publication may be trademarks whose use by third parties for their own purposes could violate the rights of the owner.

Copyright Siemens AG 2004. All rights reserved.

The distribution and duplication of this document or the utilization and transmission of its contents are not permitted without express written permission. Offenders will be liable for damages. All rights, including rights created by patent grant or registration of a utility model or design, are reserved.

Disclaimer of Liability

We have reviewed the contents of this publication to ensure consistency with the hardware and software described. Since variance cannot be precluded entirely, we cannot guarantee full consistency. However, the information in this publication is reviewed regularly and any necessary corrections are included in subsequent editions.

Preface

Purpose of this manual

This manual provides a comprehensive overview of the **C7-636 Control System**. It offers support for the installation and commissioning of this device. The manual explains how to install expansion modules and introduces the corresponding components.

This manual is intended for persons having the required qualifications to commission, operate, and program the hardware product described.

Basic knowledge requirements

A general knowledge of automation systems engineering is prerequisite for understanding the topics dealt with in this manual.

Users should also be familiar with the operation of computers or auxiliary programming equipment similar to PCs, operating under the operating system platform Windows 95/98/2000/NT or XP. Users should also be familiar with the STEP 7 standard software. For information, refer to the *Programming with STEP 7* manual.

In particular when using a PLC in hazardous locations, pay attention to the information on the safety of electronic controls in chapter "Technical data."

Scope of this Manual

This manual is applicable to the following:

C7	Order number	As of version	
		Firmware	Hardware
C7-636 Touch	6ES7636-2EB00-0AE3	CPU V 2.0.8 HMI V 6.0.2.23 HMI Bootlader V 1.3	01
C7-636 Key	6ES7636-2EC00-0AE3	CPU V 2.0.6 HMI V 6.0.2.23 HMI Bootlader V 1.3	01

This manual describes the device version that is valid at the time this manual is issued.

Approbation

For detailed information on approvals and standards, refer to chapter "Technical data".

Standards

The C7-636 meets the requirements and criteria of IEC 61131-2.

Its position in the IT environment

The SIMATIC C7-636 consists of the following components:

- SIMATIC S7 315-2 DP CPU, including the I/O sub-modules of the 314C-2 DP CPU
- SIMATIC Touch Panel TP 270 10" (C7-636 Touch) and / or Operator Panel OP 270 6" (C7-636 Key)

Manuals providing detailed information on these individual components are included in a documentation package. These manuals are essential when working with the C7-636.

The documentation package consists of six manuals and an instruction list:

Name of manual	Description
YOU ARE READING THE device manual C7-636 Control System	Description <ul style="list-style-type: none"> • of installation and wiring • of operation. • Technical data of the C7-636
Device manual Multi Panel MP 270B, Touch Panel TP 270, Operator Panel OP 270	Provides information about: <ul style="list-style-type: none"> • Functionality • Device description • Operating modes and operation of the OP/TP
Device manual CPU 31xC and CPU 31x, technical data	Description of the operation, function and technical data of the CPU.
Manual CPU 31xC: Technological functions Examples	Description of the individual technological functions: <ul style="list-style-type: none"> • Positioning • Counting • Controlling The CD contains examples of the technological functions.
Operating instructions S7-300, CPU 31xC and CPU 31x: Installation	Configuration, installation, wiring, addressing, putting into operation, maintenance and test functions, diagnostics and fault recovery.
Reference manual S7-300 Programmable Controller: Module data	Description of functions and technical specifications of signal modules, power supply modules and interface modules.
Instruction list CPU 31xC und CPU 31x, IM 151-7 CPU, BM 147-1 CPU, BM 147-2 CPU	List of the CPU instruction set and the corresponding execution times List of executable blocks

Additional documentation

The following manuals are provided to support you when programming and configuring the C7-636:

Name of manual	Description
Manual <ul style="list-style-type: none"> • ProTool Configuring Windows-based systems	Manual for creating configurations with ProTool <ul style="list-style-type: none"> • Operation of ProTool • Configuration • Screens and messages • Downloading configuration to the C7
Manual <ul style="list-style-type: none"> • Programming with STEP 7 	Basics for programming in STEP 7
Reference manual <ul style="list-style-type: none"> • Instruction list (IL) for S7-300/400 PLCs or <ul style="list-style-type: none"> • Ladder diagram (LAD) for S7-300/400 PLCs or <ul style="list-style-type: none"> • Function block diagram (FBD) for S7-300/400 PLCs 	Manual for programming in STL, LAD or FBD

Guide

This manual contains the following elements to help you access particular information quickly and easily:

- Complete table of contents at the front of the manual.
- There is a detailed keyword index at the back of the manual.

Recycling and disposal

The C7-636 system can be recycled due to its low-contaminant equipment. Contact a certified company for the environment-friendly recycling disposal of your electronic waste.

Table of contents

	Preface	iii
1	Guide through the document landscape	1-1
1.1	Additional documentation.....	1-1
2	Product overview	2-1
2.1	Design and structure.....	2-1
2.2	Function	2-6
2.3	Scope of delivery of the C7-636.....	2-8
2.4	Components and options required for operating	2-9
3	Installation and wiring	3-1
3.1	Plant-specific with labeling strips (only C7-636 Key).....	3-1
3.2	Insert labeling strips (only C7-636 Key).....	3-2
3.3	Mechanical arrangement of the C7-636	3-3
3.4	Mechanical installation.....	3-4
3.5	Installing and wiring the optional backup battery	3-12
3.6	Connector pin assignments	3-15
3.7	Device connections.....	3-26
3.8	Guidelines for interference-proof installation	3-27
3.9	Connecting shielded cables	3-28
3.10	Coding the connector elements to prevent interchanging	3-30
4	Special features of the C7-636	4-1
4.1	Differences to standard components.....	4-1
4.2	Mode selection.....	4-1
4.3	CPU memory reset	4-4
4.4	Status and error displays of the control system.....	4-5
4.5	Arrangement of S7-300 expansion modules	4-6
4.5.1	Arrangement of S7-300 expansion modules	4-6
4.5.2	Connecting a maximum of two S7-300 modules directly to the C7-636.....	4-7
4.5.3	Connecting a maximum of four S7-300 modules directly to the control system.....	4-9
4.5.4	Connecting a maximum of four S7-300 modules at a distance of max. 1.5 m.....	4-11
4.6	Status display of the on-board digital I/O.....	4-12
5	Maintenance	5-1
5.1	Cleaning the display.....	5-1
5.2	Replacing the optional backup battery.....	5-2

5.3	Replacing the C7-636	5-3
5.3.1	Replacing the control system	5-3
5.3.2	Dismantling a control system with CF card	5-4
5.3.3	Installing a control system with CF card	5-4
5.3.4	Dismantling a control system without CF card	5-5
5.3.5	Installing a control system without CF card	5-6
6	Technical data	6-1
6.1	Overall technical data of the device	6-1
6.2	Technical data TP/OP	6-4
6.3	Technical data of the CPU	6-8
6.4	Technical data of integrated I/O	6-13
6.5	Notes on the power supply	6-21
6.6	Approvals	6-21
6.7	Notes on the CE Label	6-24
6.8	Notes for machine manufacturers	6-25
6.9	Technical support	6-26
	Index	

Tables

Table 3-1	Power supply connector X1	3-19
Table 3-2	PG connection (MPI) X2	3-20
Table 3-3	DP connector X3	3-20
Table 3-4	Pin assignment of I/O connector X10	3-21
Table 3-5	Pin assignment of I/O connector X11	3-22
Table 3-6	Pin assignments of I/O connector X12	3-23
Table 3-7	Pin assignment of I/O connector X13	3-23
Table 3-8	RS232 connector X4	3-25
Table 3-9	Connector pin assignment analog output X14	3-25
Table 3-10	Pin assignment of the USB interface X 6	3-25
Table 3-11	Cables for connection to the control system	3-26
Table 4-1	Mode selector keys	4-3
Table 4-2	Description of the DI/DO status display	4-12
Table 6-1	Technical data of the C7-636	6-1
Table 6-2	TP/OP scope of functions	6-4
Table 6-3	Technical data of the CPU	6-8
Table 6-4	Digital inputs	6-13
Table 6-5	Digital outputs	6-15
Table 6-6	Analog inputs	6-17
Table 6-7	Analog outputs	6-19

Guide through the document landscape

1.1 Additional documentation

Information overview

This guide lists the essential topics, and indicates which manuals in the documentation package contain the relevant information.

Information on ...	is found in this manual, in ...	Reference
Product overview	Chapter 2	
Installation and wiring	Chapter 3	
Special features of the C7-636	Chapter 4	
Control and display elements	Chapter 4.2 to 4.4	
Memory		
<ul style="list-style-type: none"> SIMATIC Micro Memory Card (MMC) for the CPU 		<i>CPU 31xC and CPU 31x, Technical data</i>
<ul style="list-style-type: none"> CPU memory concept 		<i>CPU 31xC and CPU 31x, Technical data</i>
<ul style="list-style-type: none"> Compact Flash Card (CF-Card) for the TP/OP 		<i>Multi Panel MP 270B, Touch Panel TP 270, Operator Panel OP 270, Chapter 11</i>
Commissioning the HMI elements		<i>Multi Panel MP 270B, Touch Panel TP 270, Operator Panel OP 270, Chapter 3</i>
Operating the HMI element		<i>Multi Panel MP 270B, Touch Panel TP 270, Operator Panel OP 270, Chapter 4</i>
Data areas for communication between C7-OP and C7-CPU		<i>SIMATIC HMI, communication for Windows-based systems, Chapter 7</i>
Screen objects		<i>Multi Panel MP 270B, Touch Panel TP 270, Operator Panel OP 270, Chapter 5</i>

Information on ...	is found in this manual, in ...	Reference
System settings		<i>Multi Panel MP 270B, Touch Panel TP 270, Operator Panel OP 270, Chapter 8</i>
Maintenance	Chapter 5	
Technological functions		<i>CPU 31xC: Technological functions</i>
Technical data	Chapter 6	
Scope of functions	Chapter 6	

Product overview

2.1 Design and structure

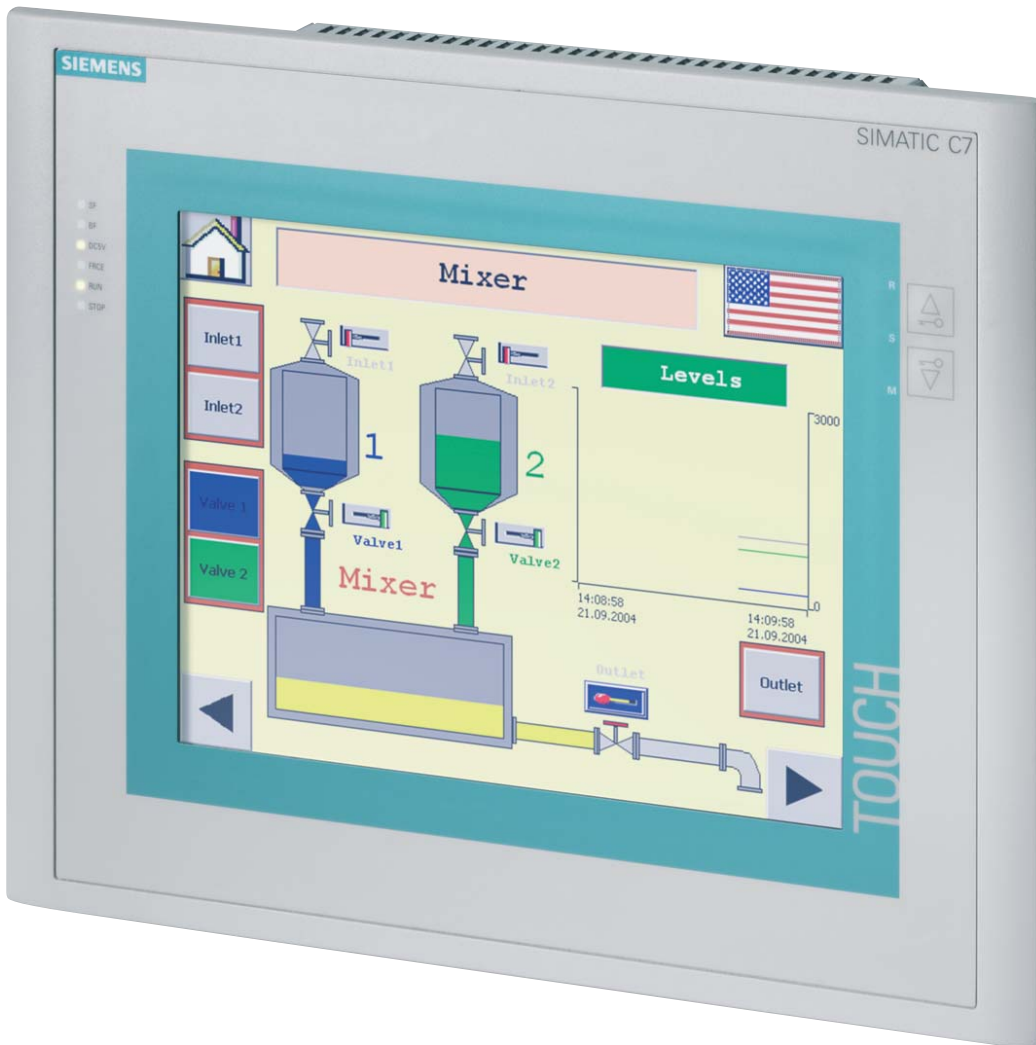

Figure 2-1 C7-636 touch front view

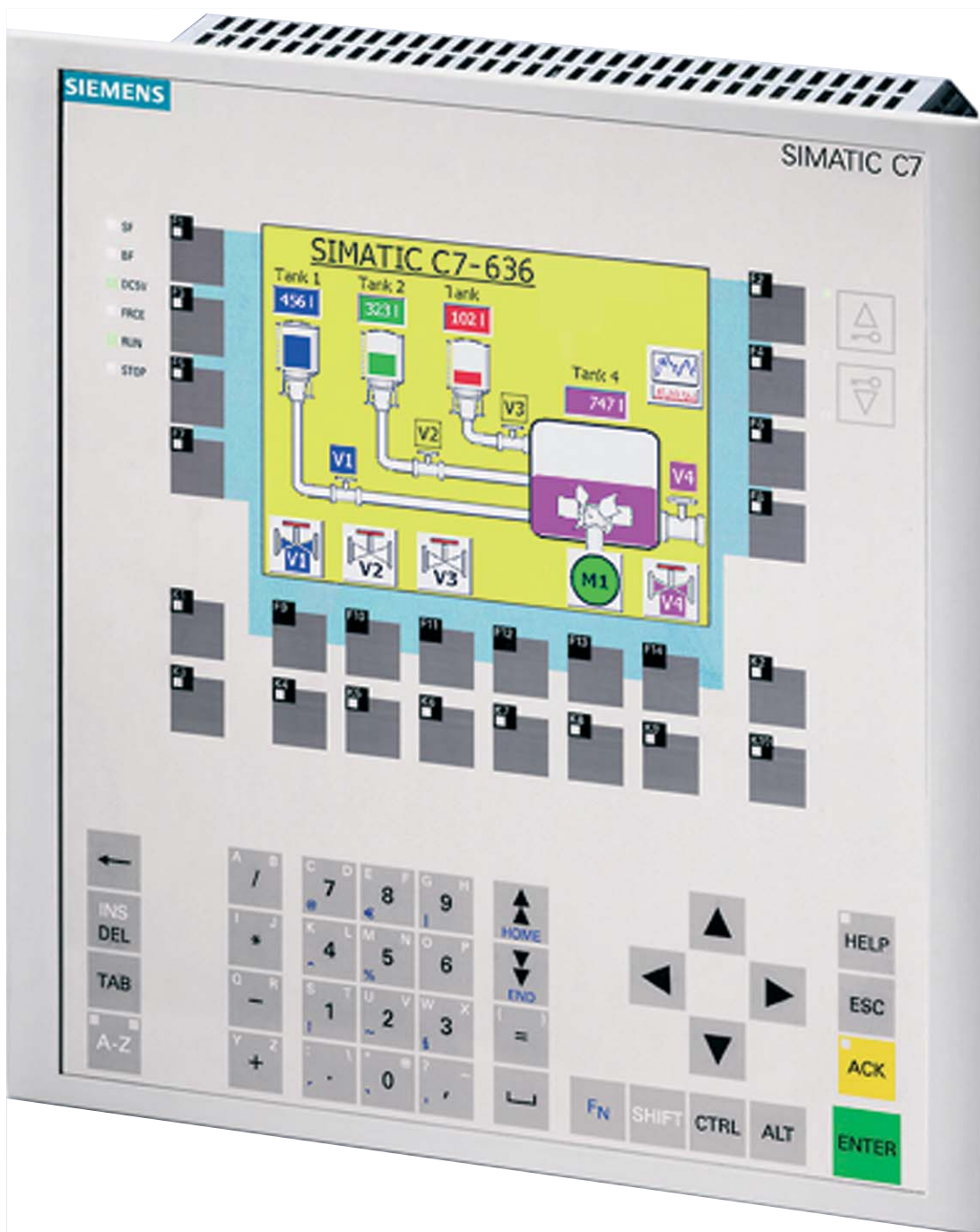

Figure 2-2 C7-636 Key front view

Components

The SIMATIC C7-636 consists of the following components

- SIMATIC S7 315-2 DP CPU, including the I/O sub-modules of the 314C-2 DP CPU
- SIMATIC Touch Panel TP 270 10"

The SIMATIC C7-636 Key consists of the following components

- SIMATIC S7 315-2 DP CPU, including the I/O sub-modules of the 314C-2 DP CPU
- SIMATIC Operator Panel OP 270 6"

Interfaces

SIMATIC C7-636 interfaces:

- An interface for connecting up to four S7-300 modules via the S7-300 I/O bus
- Integrated digital and analog I/O (same as I/O of the 314C-2 DP CPU)
- DP interface for the communication with nodes on a PROFIBUS DP network
- MPI interface for the communication with a PG/PC and further S7 CPUs, C7 control systems and TPs/OPs
- USB interface
- RS232 interface (e.g. as printer port)
- Micro Memory Card (MMC)
- Compact Flash Card (CF Card)
- Battery plug (for backing up the real-time clock of the TP/OP)

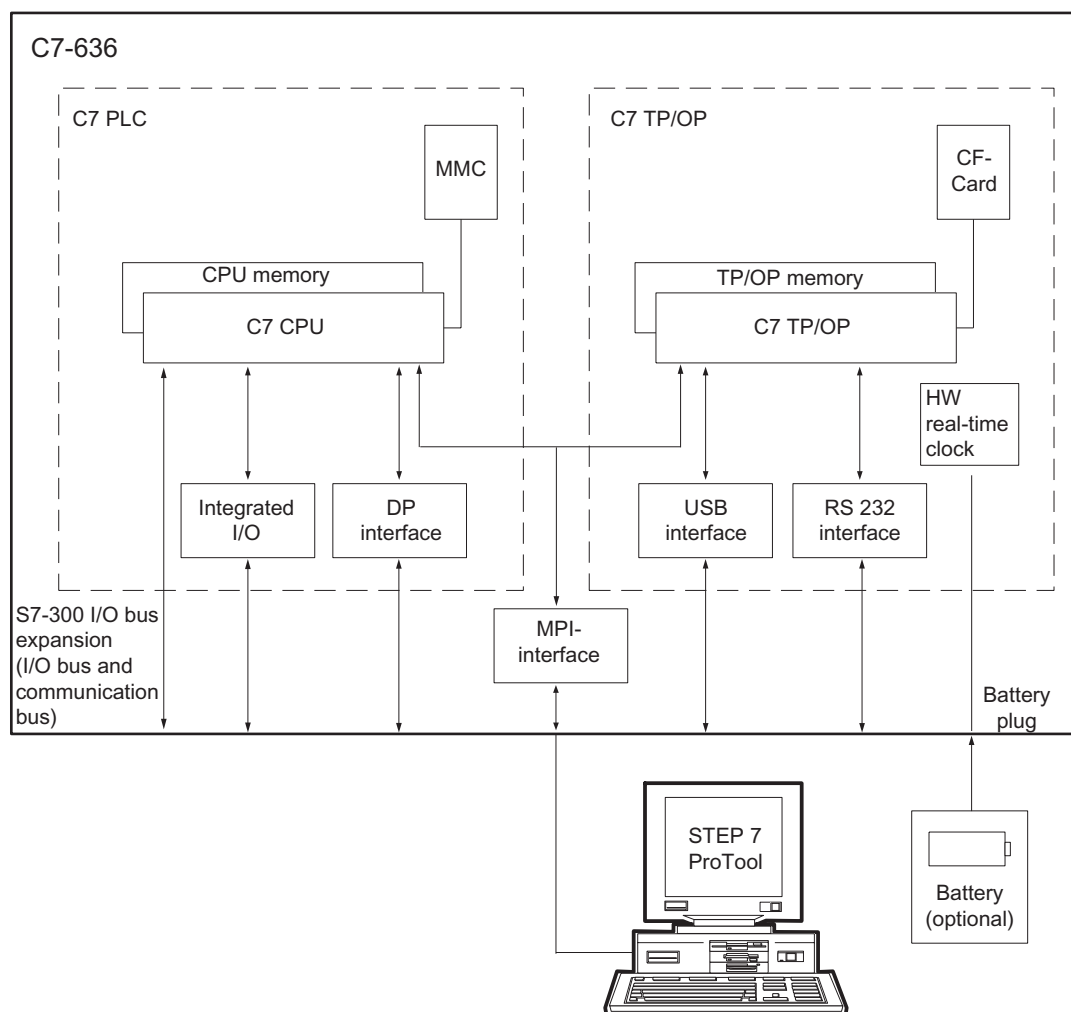

Figure 2-3 Components and interfaces of the C7-636

I/O expansion on the S7-300 I/O bus

The following optional accessories enable an I/O expansion via the S7 300 I/O bus without IM interface module:

- 2-module I/O set: Expansion by maximum 2 S7-300 modules
- 4-module I/O set: Expansion by maximum 4 S7-300 modules

You can add an IM-360 interface module in order to connect up to three expansion rows for a maximum of 23 S7 300 modules.

2.2 Function

Interaction between the CPU and OP

The individual components integrated in the SIMATIC C7-636 correspond to those which can also be used in a modular structure consisting of a 315-2 DP CPU, including 314C-2 DP I/O sub-modules and the TP270 10" and / or OP 270 6":

The function principle also corresponds with an installation consisting of standard modules of the PLC and TP/OP family. The individual components operate independently, and each processor is assigned its own memory area.

The C7 CPU and the C7 TP/OP communicate internally via the MPI interface.

The C7 CPU is independent of the C7 TP/OP. For example, the C7 TP/OP continues to operate when the C7 CPU goes into STOP mode.

CPU

The user program controlling the process runs on the C7-636.

The following functional units determine the mode of operation of the C7-636:

- Load memory

The load memory is located on the Micro Memory Card (MMC) and contains the user program.

- Processor

The processor executes the program cyclically:

- At the beginning of the cycle, the processor reads the signal states of all inputs and generates a process image of the inputs (PII).
- The program is executed sequentially, using internal counters, flags and timers.
- The processor stores the calculated signal states in the process output image (POI). At the end of the cycle, the process image is transferred to the outputs.

Scope of functions of the CPU

- CPU with 128 KB RAM
- Various sizes of load memory and retentive memory in the Micro Memory Card
- Integrated I/O
 - 24 digital inputs
 - 16 digital outputs
 - 4 analog inputs
 - 2 analog outputs
 - 1 PT 100

- Technological functions
 - Positioning with an analog output or digital outputs
 - Counters, frequency measurements, or pulse width modulation (only two channels are available when the positioning function is used)
 - Controlling
- PROFIBUS DP Interface

Touch Panel / Operator Panel

The C7-636 Touch Panel and Operator Panel are based on the standard operating system Windows CE. This allows you to visualize operational states, current process values and error messages. You can also input data on the C7-636. Simple machine diagnostic functions are also possible.

You can also incorporate your own images, digital pictures, and scanned images into your project. Moreover, you can visualize temperature profiles graphically by means of bar graphs and trends, for example.

Touch Panel / Operator Panel scope of functions

- Internal 64 KB memory space for recipes, expandable with Compact Flash Card (CF-Card), 2 MB memory space for configuration data.
- Password protection
- Input and output boxes for viewing and changing process parameters
- Configurable buttons and function keys (C7-636 Key) for controlling I/O data and data bits
- Bar graphs for displaying dynamic values
- Standard library of images and buttons that can be used in ProTool CS
- Images that can be used to label buttons or configured as full format background images
- Permanent text for labeling buttons, process images, and process values in any font size
- Print functions
- Message processing
- Curves
- Watchdogs
- Recipe management
- Backup of recipe and configuration data on optional memory card (CF card)

You will find a complete overview of the scope of functions in chapter "Technical specifications".

Programming and configuring

Note

The C7 CPU and the C7 TP/OP are assigned separate MPI addresses. Hence, you program and configure these components in exactly the same way as independent CPU and TP/OP components.

These items are addressed explicitly in the manual, as necessary.

You program the C7-636 Touch with STEP 7 as of V 5.2 + Service Pack 1 + Hardware Update C7-636 Touch V2.0.

You program the C7-636 Key with STEP 7 as of V 5.2 + Service Pack 1 + Hardware Update C7-636 Key V2.0.

The programming languages available for the system are specified in the *CPU 31xC and CPU 31x, technical data* manual.

You configure the C7-636 using ProTool as of V 6.0 + Service Pack 2 + Setup. You'll find the Setup on the Internet under

<http://www.siemens.com/automation/service&support>

under the subscription ID 17890405.

The tools run on a PG or PC under Windows.

2.3 Scope of delivery of the C7-636

Scope of delivery

The following components are included with the C7-636 Touch, order no. 6ES7636-2EB00-0AE3:

- 1 C7-636 Touch with sealing
- 1 grounding busbar, including two mounting screws and six shielding terminals
- 8 brackets and 1 Allen wrench

The following components are included with the C7-636 Key, order no. 6ES7636-2EC00-0AE3:

- 1 C7-636 Key with sealing
- 1 grounding busbar, including two mounting screws and six shielding terminals
- 10 brackets

2.4 Components and options required for operating

What you need for operating the C7-636

- A Micro Memory Card (MMC) to store the CPU user program that is programmed with STEP 7. The C7-636 can only be operated with the MMC.

Micro Memory Card S7-300/C7/ET 200S IM151 CPU 3,3 V NFLASH:

64 KB	6ES7953-8LF11-0AA0
128 KB	6ES7953-8LG11-0AA0
512 KB	6ES7953-8LJ11-0AA0
2 MB	6ES7953-8LL11-0AA0
4 MB	6ES7953-8LM11-0AA0
8 MB	6ES7953-8LP11-0AA0

- A 24 V DC power supply module
- A connector set for the C7 I/O with coding profiles and tab, or alternatively:
 - Connector set with screw terminals
order no.: 6ES7635-0AA00-4AA0
 - Connector set with spring-type terminals
order no.: 6ES7635-0AA00-4BA0
- A PG or PC with MPI interface and MPI cable for creating the user program, or alternatively, a PG / PC with read / write access to an MMC or if necessary a CF Card
- STEP 7 as of Version 5.2 + Service Pack 1 + Hardware Update C7-636 Touch V2.0 for the C7-636 Touch
- STEP 7 as of Version 5.2 + Service Pack 1 + Hardware Update C7-636 Key V2.0 for the C7-636 Key
- The engineering tool ProTool as of V 6.0 + Service Pack 2 + Setup

Options

I/O expansion

C7-636 accessories available for I/O expansion (directly on the device or up to a maximum distance of 1.5 m).

- I/O set for two modules, set flat (for I/O expansion directly on the device)
order no.: 6ES7635-0AA00-6AA0

Consisting of:

- A cable, approximately 0.25 m (for connecting the C7-636 to the S7 module)
- A cable, approximately 0.08 m (for connecting an S7 module to the S7 module)
- Sheet metal mounting panel with S7 profile rails, including four combination torx screws (the mounting panel is screwed to the back of the device)

2.4 Components and options required for operating

- I/O set for four modules, set deep (for I/O expansion directly on the device)
order no.: 6ES7635-0AA00-6BA0
Consisting of:
 - Cable, approximately 0.20 m
 - 190-mm S7 profile rail, including 4 countersunk screws (to be screw-mounted on the back of the device)
- I/O expansion cable, 1.5 m (for I/O expansion up to a distance of max. 1.5 m)
order no.: 6ES7635-0AA00-6CA0
You must order an additional S7-300 PLC standard DIN rail.

Backup battery

To ensure that, in the event of a power failure, the internal hardware clock of the operating device continues running, you need a backup battery. The battery should be ordered from the Siemens spare parts department. The battery is supplied ready for installation, including the cable and plug.

Order number: W79084-E1001-B2

Compact Flash Card

- You need a Compact Flash Card (CF Card) for the OP in the following cases:
 - You need more than 64 KB memory for recipes
 - You want to be able to replace the C7-636 without having to use a PG / PC

Spare parts

- Grounding busbar with shielding terminals for analog I/O
order no.: 6ES7635-0AA00-6EA0
- Service package for C7-636 Key (sealing and 10 brackets)
order no.: 6ES7635-0AA00-3AA0
The sealing must also be replaced when you replace a C7-636 Key.
- Service package for C7-636 Touch (sealing, 10 brackets and Allen wrench)
Order number: 6AV6574-1AA00-2CX0

C7 accessories

- MPI cable (connecting C7 to PG)
order no.: 6ES7901-0BF00-0AA0
- Pc adapter (connecting C7 to PG)
order no.: 6ES7972-0CA23-0XA0
- RS232 cable (null modem cable)
order no.: 6ES7901-1BF00-0XA0
- Protective film for the display of the C7-636 Touch
order no.: 6AV6574-1AD00-4CX0

Documentation

- Manual *C7-636 control system* in printed format

Language	Order number
German	6ES7636-1AA00-8AA0
English	6ES7636-1AA00-8BA0
French	6ES7636-1AA00-8CA0
Spanish	6ES7636-1AA00-8DA0
Italian	6ES7636-1AA00-8EA0

- *C7-636 control system*, documentation package, consisting of:
 - *C7-636 Control System* manual
 - *Multi Panel MP 270B, Touch Panel TP 270, Operator Panel OP 270* manual
 - S7 300 documentation package

Language	Order number
German	6ES7636-1EA00-8AA0
English	6ES7636-1EA00-8BA0
French	6ES7636-1EA00-8CA0
Spanish	6ES7636-1EA00-8DA0
Italian	6ES7636-1EA00-8EA0

Installation and wiring

3.1 Plant-specific with labeling strips (only C7-636 Key)

Purpose of the labeling strips

You can use the labeling strips to individually label the function keys of the C7-636 Key. The labeling strips can be inserted into the keyboard from the top and from the side.

Template for labeling strips

The template for the labeling strips is provided with ProTool (V6.0 + Service Pack 2, Utilities folder) or can be obtained from the Internet. You can design and print plant-specific labeling strips.

Internet address: <http://www.siemens.com/automation/service&support>

The file "SLIDE636.DOC" with the labeling strips can be downloaded at Product Support > Automation Systems > SIMATIC Industrial Automation Systems > PLC > SIMATIC C7 > Control Systems > Downloads

What you must note

To make your own labeling strips, use transparent film (0.1 to 0.15 mm thick) so that the LEDs of the function keys remain visible. Label the film using either a printer or a wipe-resistant foil pen.

The labeling strips have to be cut exactly along the indicated cutting edge. If the labeling strip is cut too large, it cannot be inserted.

Caution

This could soil the inside of the keyboard.

Operating pressure can cause the labeling color to rub off on the inside of the key. A key that was smudged from the inside cannot be cleaned and can only be replaced in the factory.

To avoid soiling the keyboard on the inside, protect the labeling with clear adhesive strips or an adhesive transparent film.

3.2 Insert labeling strips (only C7-636 Key)

Inserting the labeling strips

1. Place the device with the front panel facing downward.
2. Remove labeling strips that may have been previously inserted.
3. With the labeling pointing downward, insert the new labeled strip into the slits of the front panel (use tweezers, if necessary). The position of the four labeling strips is marked in the picture with arrows.

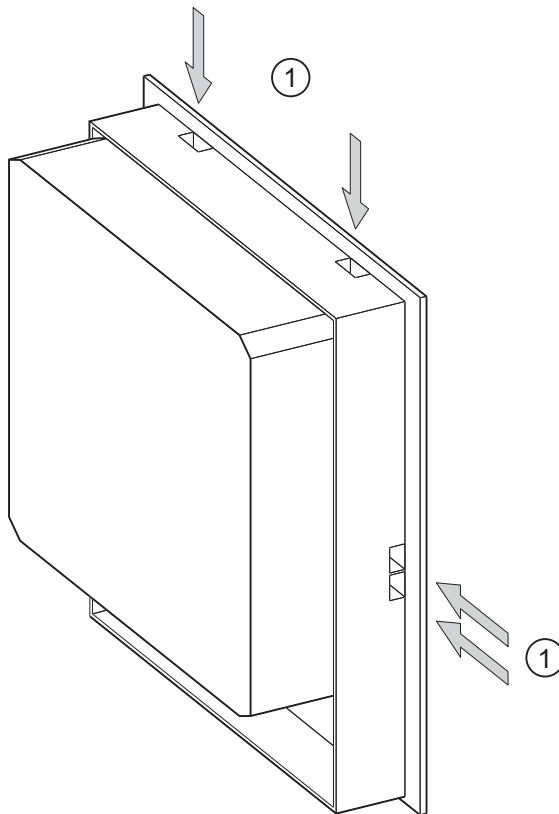

Figure 3-1 Inserting labeling strips for C7-636 Key

① Labeling strips

3.3 Mechanical arrangement of the C7-636

Placing the C7-636

When installing a C7-636, pay attention to the following:

- Make sure the sealing is firmly seated along the front panel.
- Protect the C7-636 against direct exposure to sunlight. Operation outside of closed rooms is not permitted.
- At the sides of the C7-636, keep a clearance of at least the distances given in the following illustrations for cable outlets and the air ventilation.

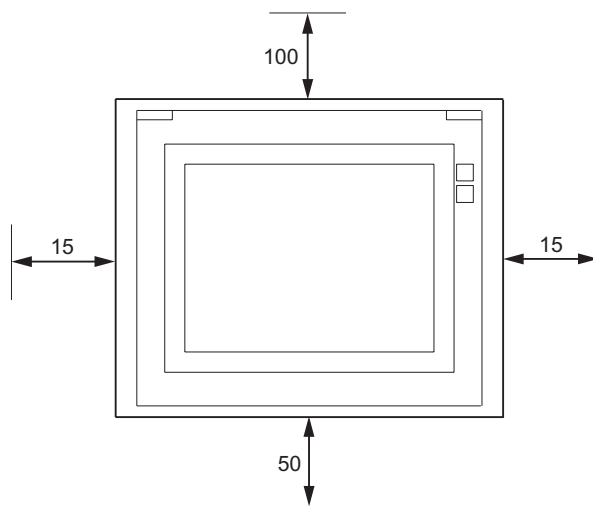

Figure 3-2 Minimum clearances to be maintained when installing the C7-636 Touch

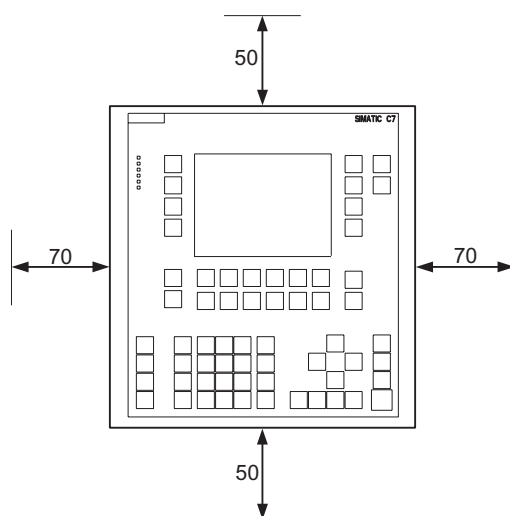

Figure 3-3 Minimum clearances to be maintained when installing the C7-636 Key

3.4 Mechanical installation

What you must note when installing

The C7-636 is designed for fixed and enclosed installation in the housing or the control cabinet.



Warning

Open facilities

Death, serious bodily injury or considerable damage to property can occur.

Modules of a C7-636 are open facilities. This means you must install the C7-636 only in a housing or cabinet.

Access to the housings or cabinets must only be possible by using a key or a tool and only authorized or approved personnel may be allowed access.

It is permissible to operate the C7-636 from its front at any time.

Notice

The degree of protection IP65/NEMA 4X can only be achieved under the following conditions:

- C7-636 Touch: The permissible sheet metal thickness of the housing or the control cabinet must at least 2.5 mm.
 - C7-636 Key: The permissible sheet metal thickness of the housing or the control cabinet must be between 2 and 4 mm.
 - Follow steps 1 to 5 during installation.
-

Caution

Property damage can occur.

The inserted CF card protrudes from the C7-636 and could therefore be damaged.

Prior to the removal and installation of the device, remove the Micro Memory Card (MMC) and the Compact Flash Card (CF Card).



Caution

Condensation may develop on the device when you take it from a cold environment to the operating area.

Before you start it, allow the device to become acclimatized to room temperature.

If condensation has developed, the device may not be switched on until it is completely dry.

Installation

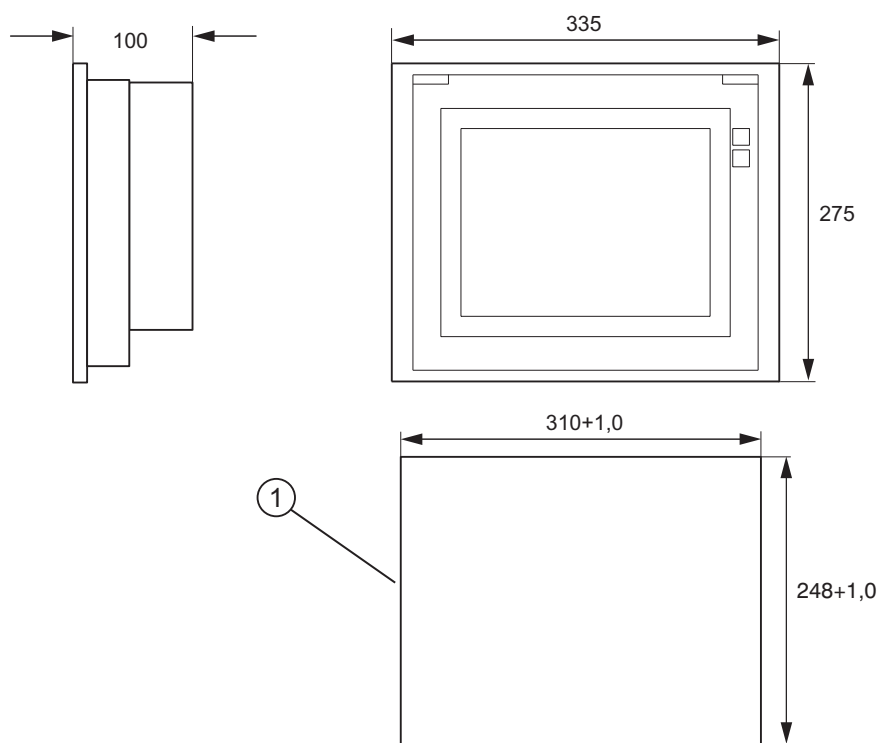

Figure 3-4 Dimension drawings for the C7-636 Touch (dimensions in mm)

- ① Cut-out section in housing or cabinet

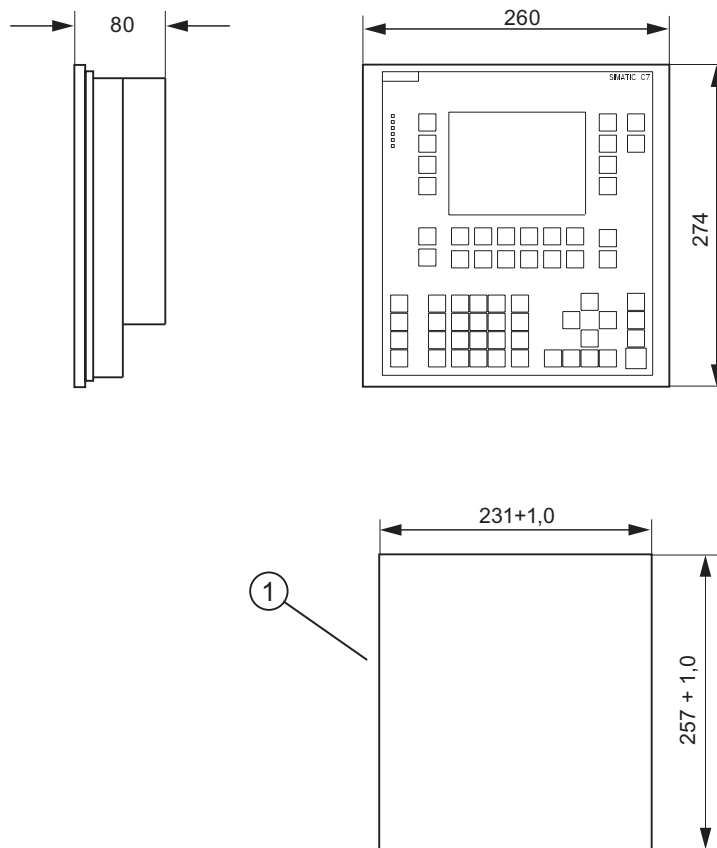

Figure 3-5 Dimension drawings for the C7-636 Key (dimensions in mm)

- ① Cut-out section in housing or cabinet

To install the device proceed as follows:

1. C7-636 Touch:

Make a cut-out in the housing or the cabinet with the dimensions 310+1.0 x 248+1.0 mm.

C7-636 Key:

Make a cut-out in the housing or the cabinet with the dimensions 231+1.0 x 257+1.0 mm.

- 2. Ensure that no Compact Flash card (CF card) is inserted in the C7636. The CF card protrudes from the C7-636 and could be damaged when you install the device.
- 3. Place the C7-636 in the cut-out section of the switching panel door. Ensure that the sealing is seated firmly on the metal plate.
- 4. Hook the mounting hooks of the included brackets into the notches provided in the enclosure of the C7-636 (C7-636 Touch: 8 brackets, C7-636 Key: 10 brackets).
- 5. Using a screwdriver, tighten the C7-636 evenly and crosswise from behind in the control cabinet door until the front panel of the C7-636 rests on the control cabinet door. Position the device so that there is even spacing on all sides between the housing and the cut-out section.

The following figure shows the mechanical fastening of the C7-636 Key.

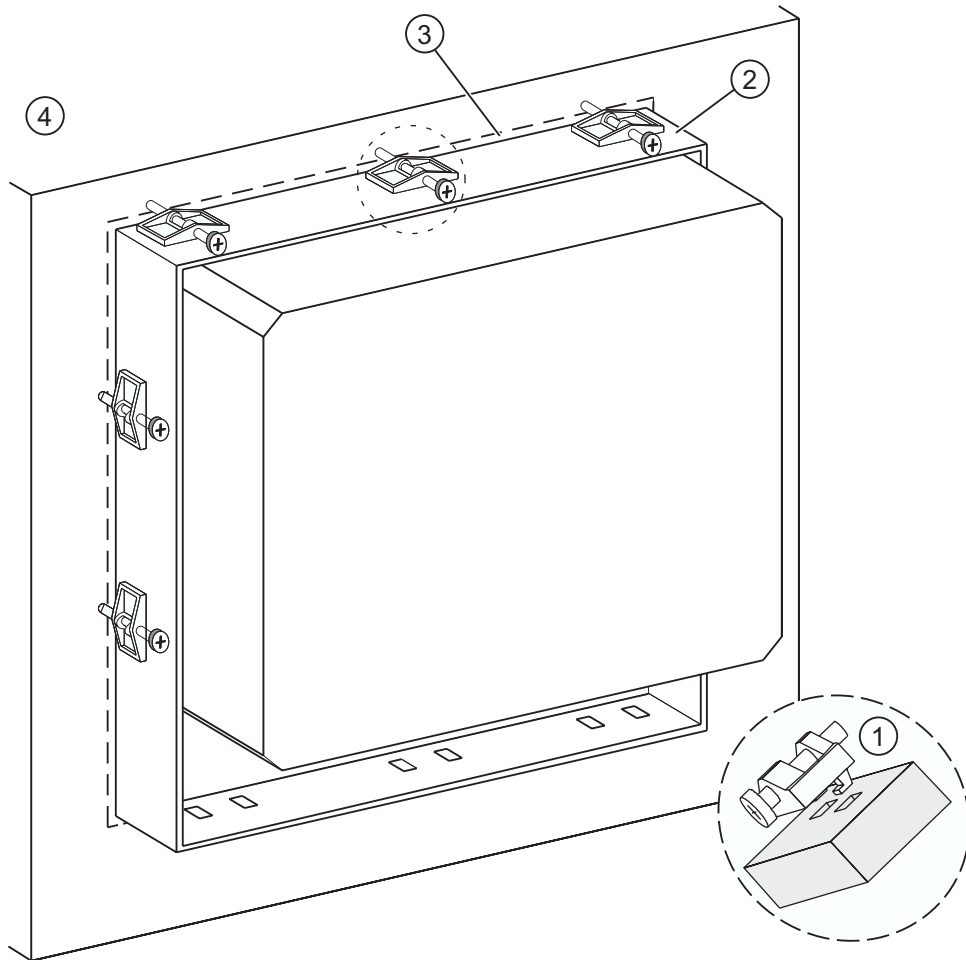

Figure 3-6 Mechanically fastening of the C7-636 Key

- ④ Housing door or cabinet door

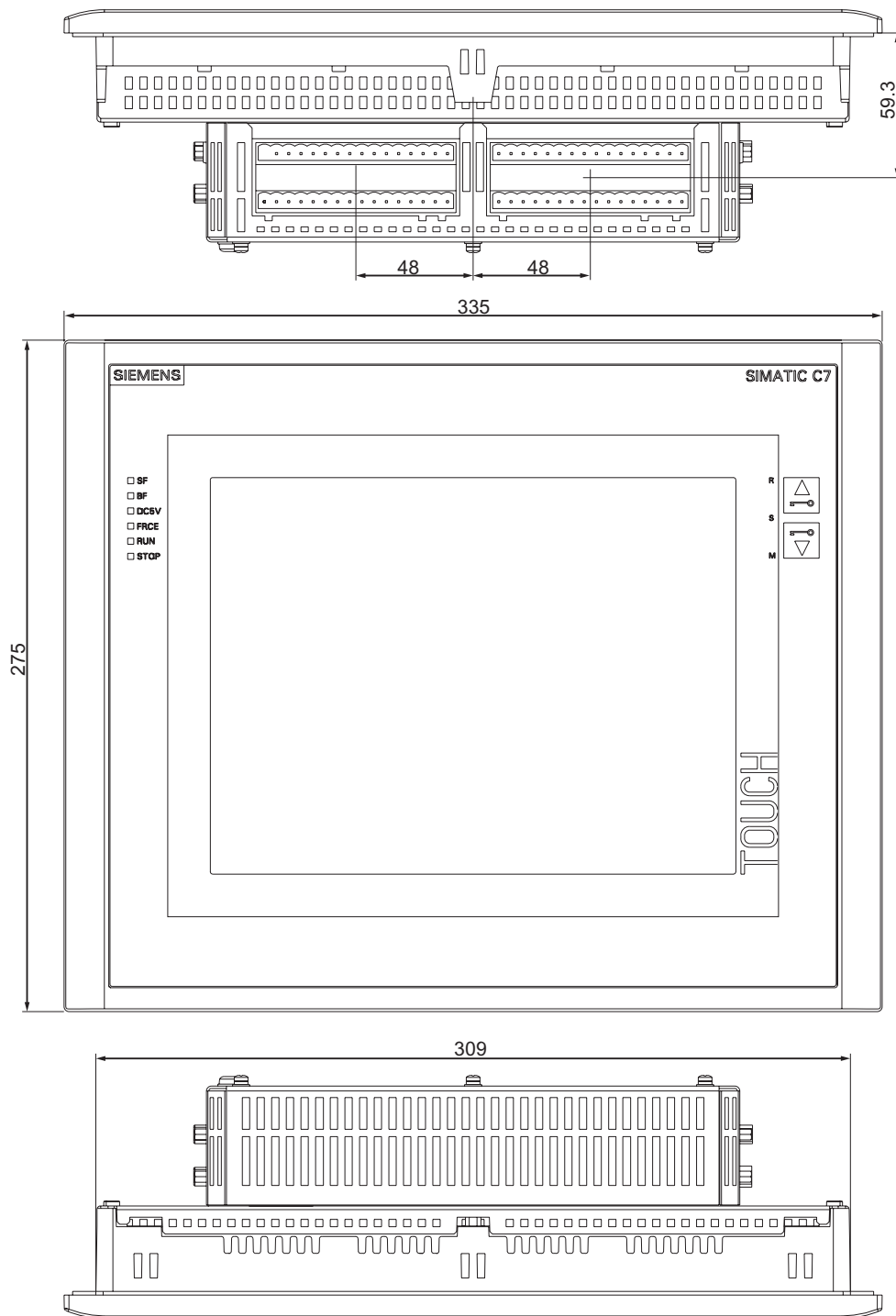

Figure 3-7 Dimension drawings for the C7-636 Touch (dimensions in mm)

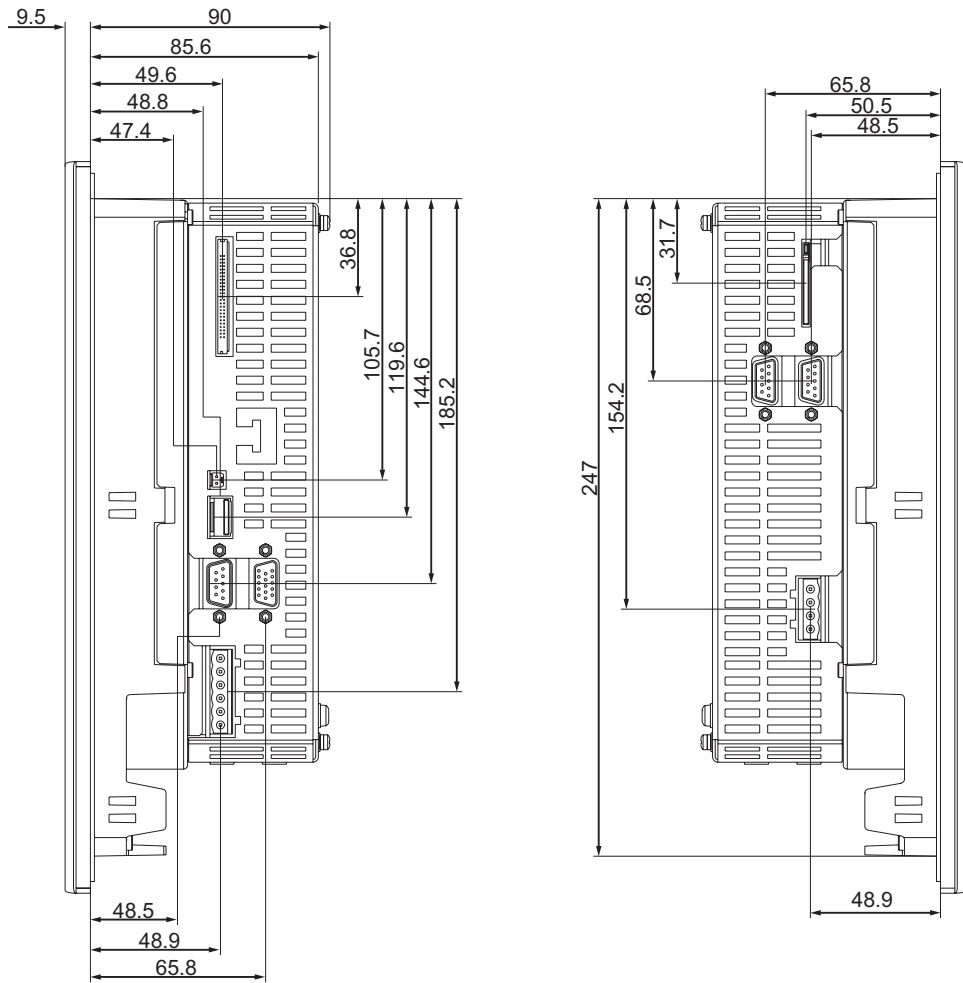

Figure 3-8 Dimension drawings for the C7-636 Touch (dimensions in mm)

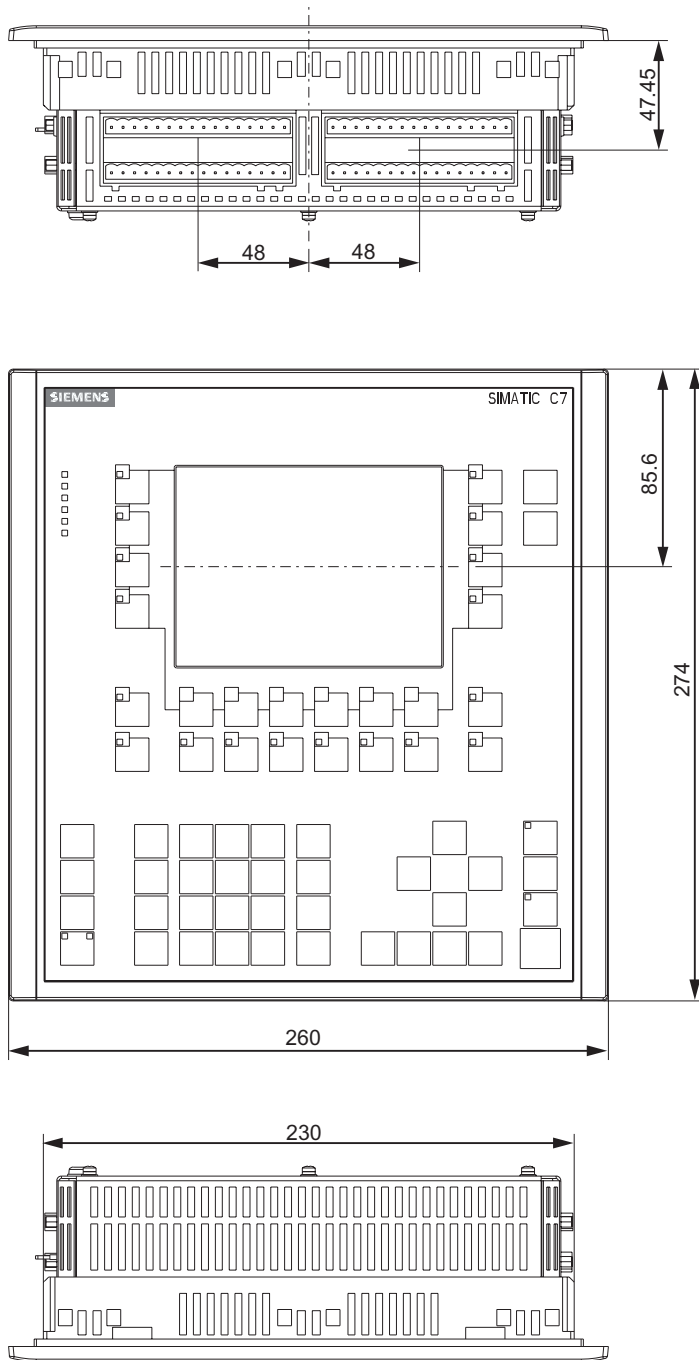

Figure 3-9 Dimension drawings for the C7-636 Key (dimensions in mm)

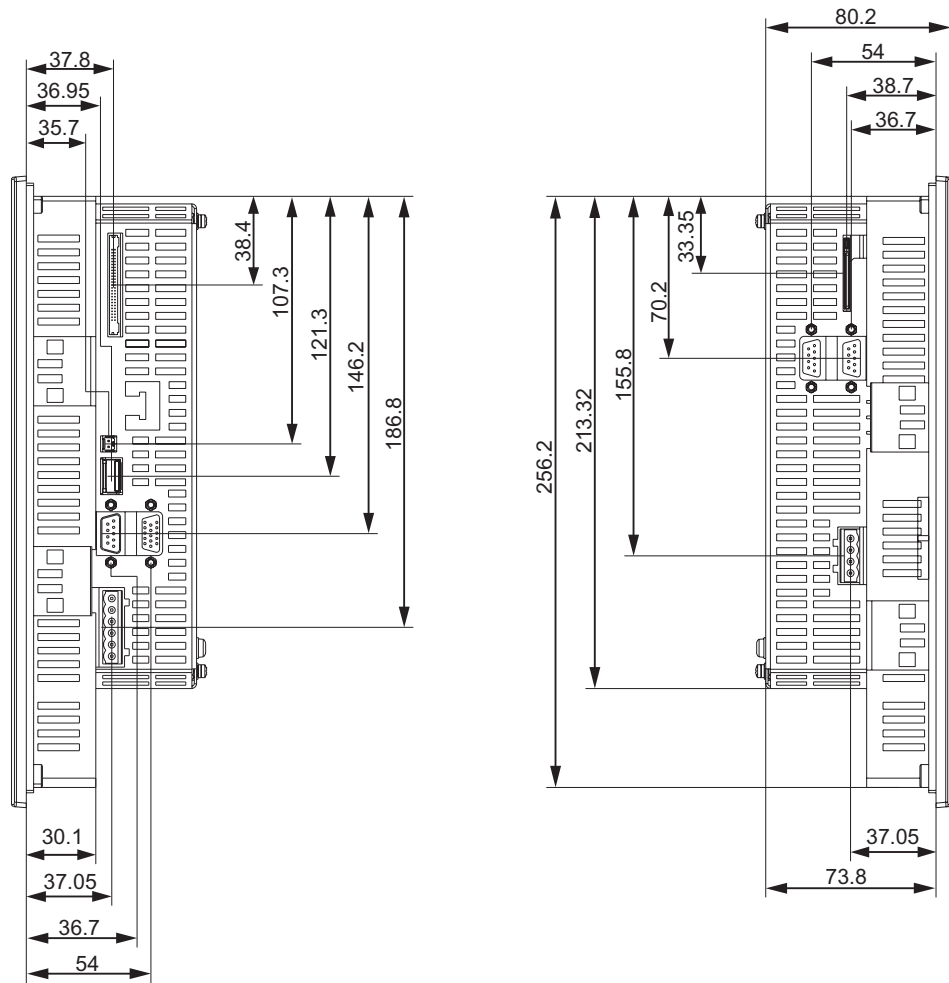

Figure 3-10 Dimension drawings for the C7-636 Key (dimensions in mm)

3.5 Installing and wiring the optional backup battery

Function of the backup battery

The purpose of the backup battery is to ensure that the internal real-time clock of the OP continues operation when power is interrupted. Without battery, this clock is buffered approx. three days, provided the C7-636 was in continuous operation for approx. 6 to 8 hours.

The battery is not supplied with the C7-636.

Under normal operating conditions, the service life of this battery is approx. four years.

Source of supply

The battery should be ordered from the Siemens spare parts department. The battery is supplied ready for installation, including the cable and plug.

Order number: W79084-E1001-B2

Installation and connection



Caution

The battery should only be installed and connected by qualified personnel.

Observe the EGB guidelines.

The photographs show the C7-636 Key. The fastening and connecting of the battery is identical in the C7-636 Touch.

1. Fasten the battery with a ty-wrap at the punched recess in the sheet metal enclosure.
2. Plug the battery cable connector into pin strip X9.

The connector is coded for protection against polarity reversal.

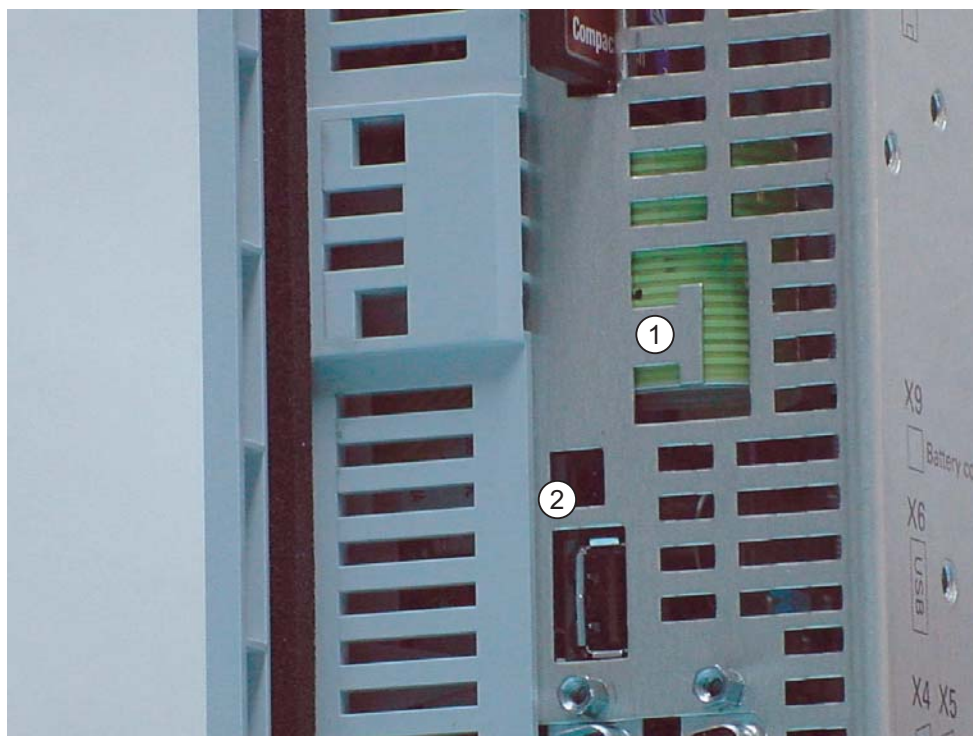

Figure 3-11 Punched recess for fastening the backup battery

- ① Punched recess for fastening the backup battery using a ty-wrap
- ② Pin strip X9

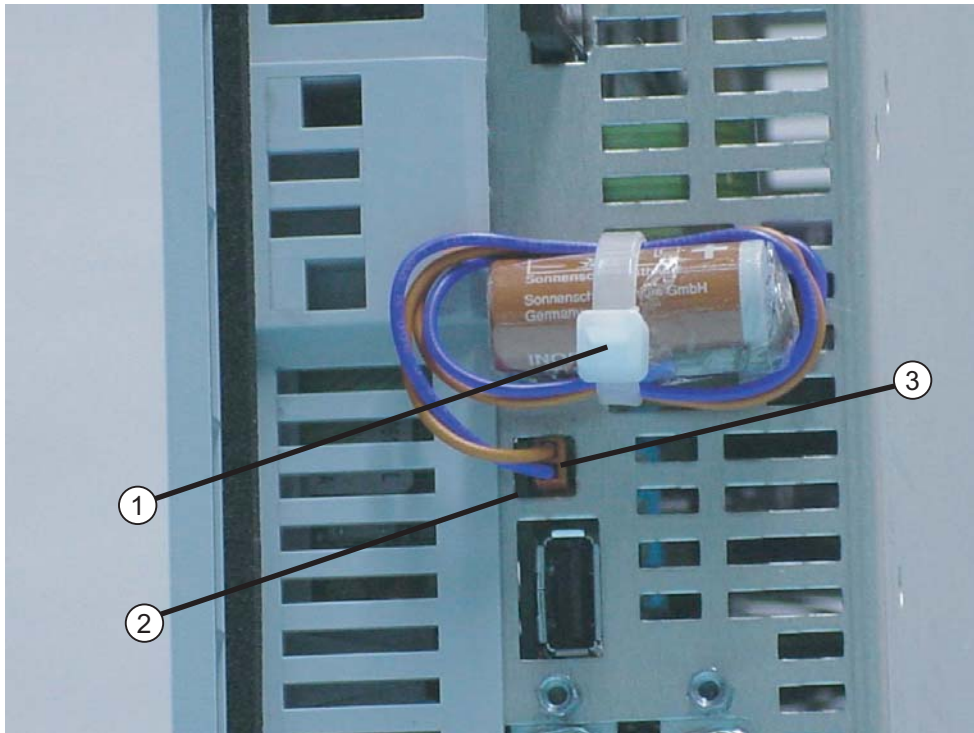

Figure 3-12 Fastening and connecting the backup battery

- ① Cable ty-wrap
- ② Pin strip X9
- ③ Battery supply connector

3.6 Connector pin assignments

Connector pin Assignment of the C7-636

The tables in this chapter illustrate the connector pin assignment of the C7-636. By way of example, the C7-636 Key is shown in the pictures. The position of the plugs and sockets is identical for the C7-636 Touch.

With respect to the connector pin assignment, the C7-636 is compatible with C7-613 and C7-635.

Caution

For functional reasons, the pin assignment is incompatible with the previous products C7-621, C7-623, C7-626, C7-633, and C7-634.

Note

It is not possible to implement the C7-636 in an ungrounded installation.

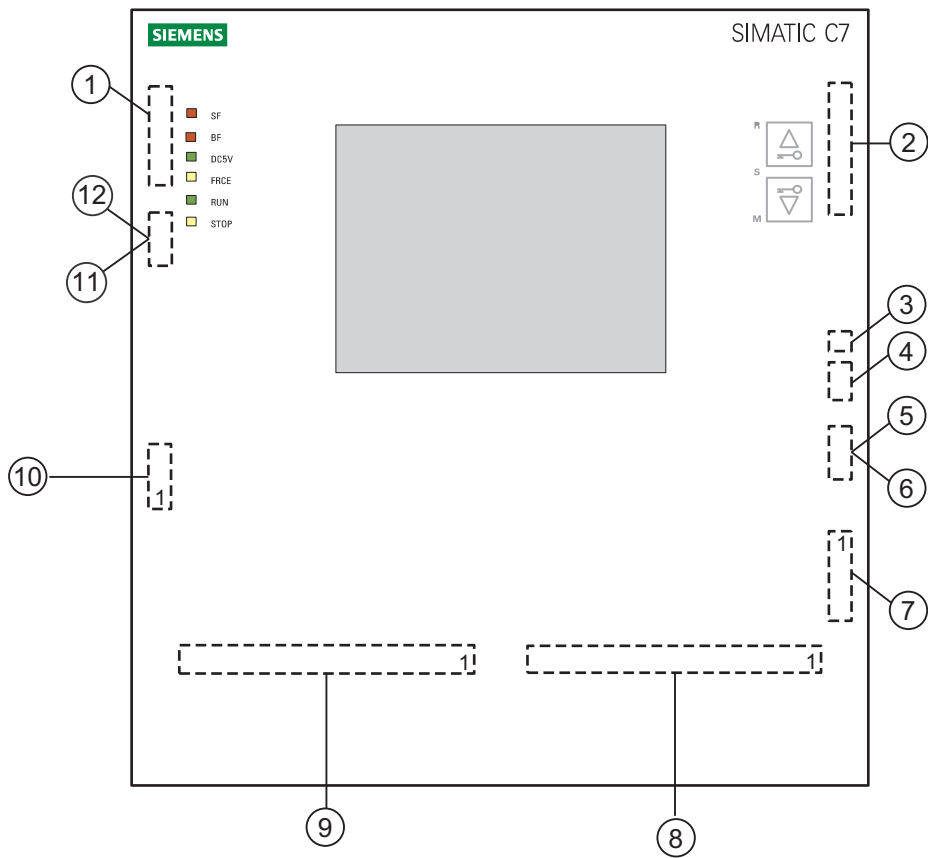

Figure 3-13 C7-636 with plugs and sockets, front view

- ① X 7: Micro Memory Card of the CPU
- ② X 8: Compact Flash Card of the OP X 8
- ③ X9: Battery
- ④ X6: USB
- ⑤ X 4 front: RS232
- ⑥ X 5 back: Backplane bus (P bus)
- ⑦ X 14: Analog output AO2
- ⑧ I/O connector
X 10 front: Supply I/O / DI 8
X 13 back: AI 4+1 PT 100
- ⑨ I/O connector
X 11 front: DI 16
X 12 back: DO 16
- ⑩ X 1: Power supply connector
- ⑪ X 2 back: PG connection (MPI)
- ⑫ X 3 front: PROFIBUS DP

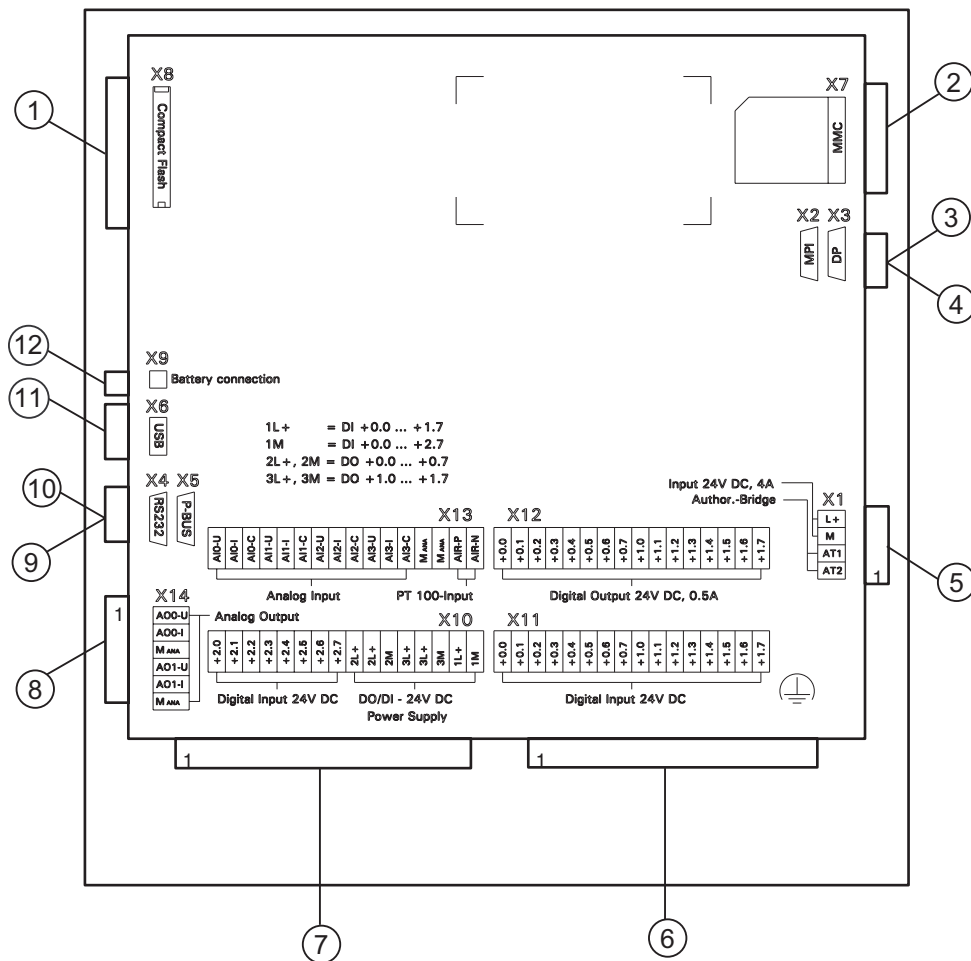

Figure 3-14 C7-636 with plugs and sockets, rear view

- ① X8: Compact Flash Card of the OP
- ② X7: Micro Memory Card of the CPU
- ③ X2 front: PG connection (MPI)
- ④ X3 back: PROFIBUS DP
- ⑤ X1: Power supply connector
- ⑥ I/O connector
X12 front: DO 16
X11 back: DI 16
- ⑦ I/O connector
X13 front: AI 4+1 PT 100
X10 back: Supply I/O / DI 8
- ⑧ X14: Analog output AO2
- ⑨ X4 back: RS232
- ⑩ X5 front: Backplane bus (P bus)
- ⑪ X6: USB
- ⑫ X9: Battery

3.6 Connector pin assignments

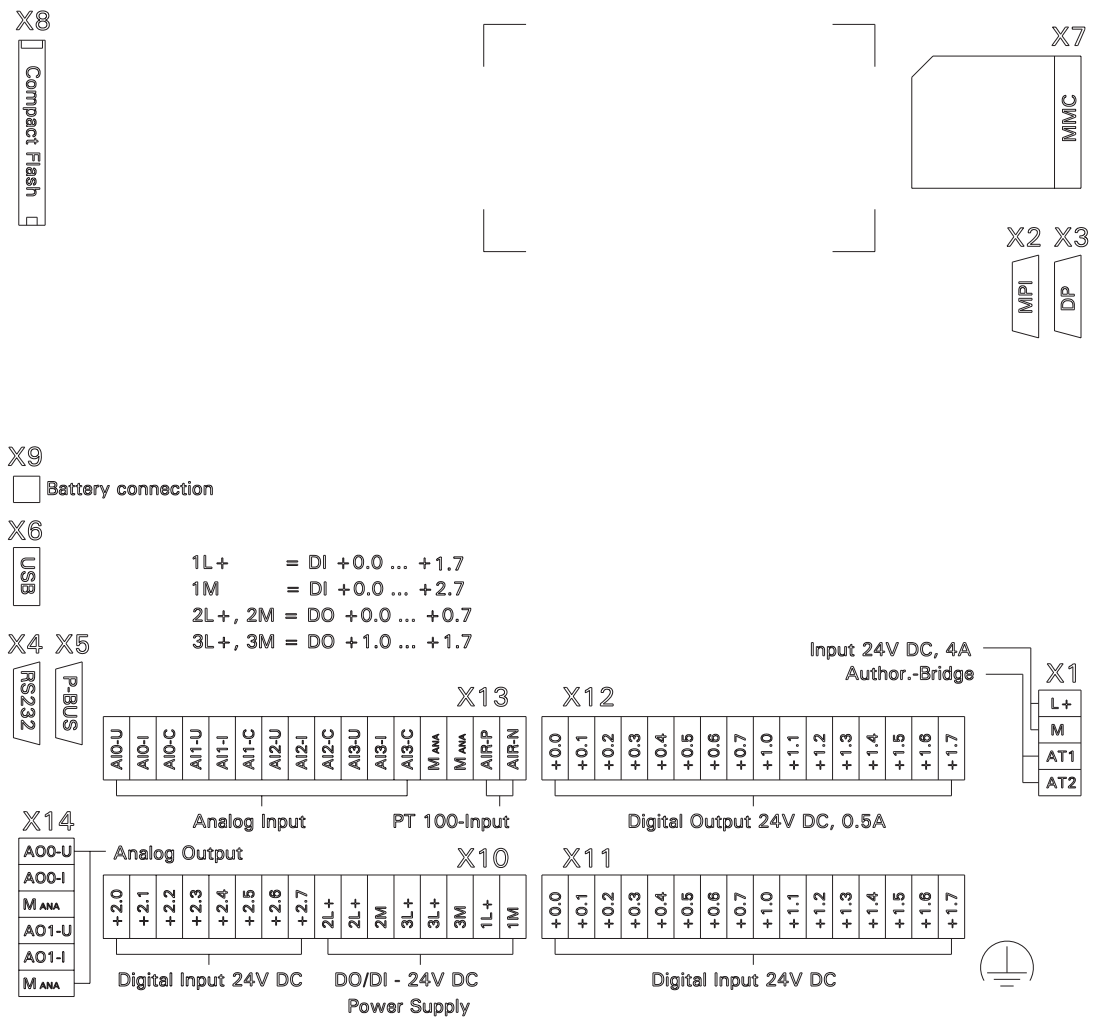

Figure 3-15 C7-636 imprint of connector pin assignment

View from left

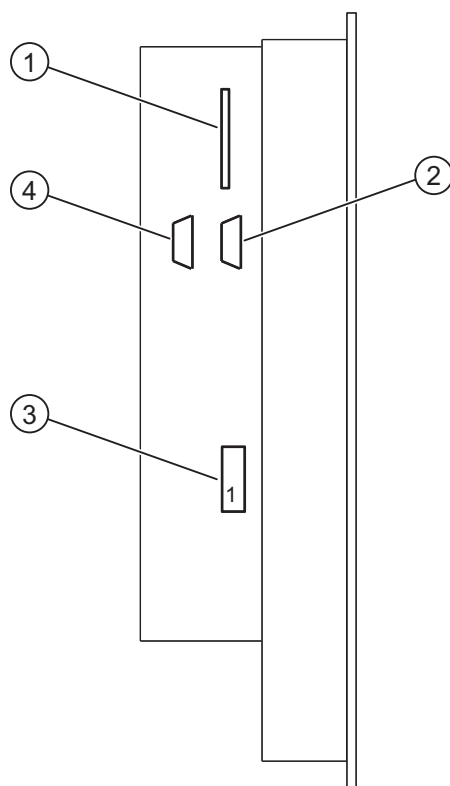

Figure 3-16 C7-636 with plugs and sockets, view from left

- ① X7: Micro Memory Card (MMC) of the CPU
- ② X3: PROFIBUS DP
- ③ X1: Power supply connector
- ④ X2: PG connection (MPI)

Power supply connector X1

Table 3-1 Power supply connector X1

Pin no.	Signal	Description
1	AT2	Authorization input (for example, for external switch)
2	AT1	Authorization input (for example, for external switch)
3	M	Ground potential 24 V DC
4	L+	Supply voltage 24 V DC

PG connection (MPI) X2

Table 3-2 PG connection (MPI) X2

Pin no.	Signal	Description
1	NC	Not connected
2	M24V	Ground potential 24 V DC
3	B	RS485 cable B
4	RTS	RTS
5	M5V	Ground potential 5 V DC
6	P5V	Supply voltage 5 V DC
7	P24V MPI	MPI supply voltage 24 V DC
8	A	RS485 cable A
9	NC	Not connected

PROFIBUS DP connector X3

Table 3-3 DP connector X3

Pin no.	Signal	Description
1	NC	Not connected
2	M24V	Ground potential 24 V DC
3	B	RS485 cable B
4	RTS	RTS
5	M5V	Ground potential 5 V DC
6	P5V	Supply voltage 5 V DC
7	P24V DP	DP supply voltage 24 V DC
8	A	RS485 cable A
9	NC	Not connected

Bottom view

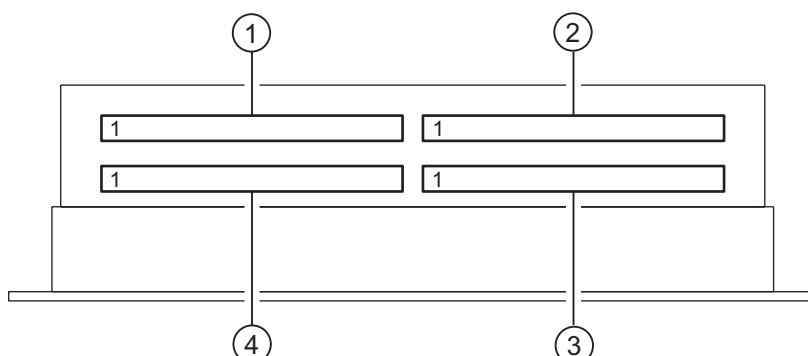

Figure 3-17 C7-636 with plugs and sockets, bottom view

- ① X 13: AI4 + 1 PT100
- ② X12: DO 16
- ③ X11: DI 16
- ④ X10: Supply I/O / DI 8

I/O connector X10

Table 3-4 Pin assignment of I/O connector X10

Pin no.	Pin designation	Signal	Description
1	X10+2.0	DI+2.0	Digital input 16
2	X10+2.1	DI+2.1	Digital input 17
3	X10+2.2	DI+2.2	Digital input 18
4	X10+2.3	DI+2.3	Digital input 19
5	X10+2.4	DI+2.4	Digital input 20
6	X10+2.5	DI+2.5	Digital input 21
7	X10+2.6	DI+2.6	Digital input 22
8	X10+2.7	DI+2.7	Digital input 23
9	2L+	L+	24 V power supply for DO 0.0 to 0.7
10	2L+	L+	24 V power supply for DO 0.0 to 0.7
11	X10 2M	M	Ground potential for DO 0.0 to 0.7
12	X10 3L+	L+	24 V power supply for DO 1.0 to 1.7
13	X10 3L+	L+	24 V power supply for DO 1.0 to 1.7
14	X10 3M	M	Ground potential for DO 1.0 to 1.7
15	X10 1L+	L+	24 V power supply for DI 0.0 to 1.7
16	X10 1M	M	Ground potential for DI 0.0 to 2.7

I/O connector X11

For the technological functions, the meaning of the inputs is described in the columns "Counting", "Frequency measurement", "Pulse width modulation", "Analog positioning", and Digital positioning."

Table 3-5 Pin assignment of I/O connector X11

Pin no.	Pin assignment	Signal/ Address	Description	Counting	Frequency measurement	Pulse width modulation	Positioning	
							Analog	Digital
1	X11+0.0	DI+0.0	Digital input 0	Channel 0: Track A / pulse		-	Encoder signal A	
2	X11+0.1	DI+0.1	Digital input 1	Channel 0: Track B / direction		-	Encoder signal B	
3	X11+0.2	DI+0.2	Digital input 2	Channel 0: Hardware gate			Encoder signal N	
4	X11+0.3	DI+0.3	Digital input 3	Channel 1: Track A / pulse		-	Length measurement	
5	X11+0.4	DI+0.4	Digital input 4	Channel 1: Track B / direction		-	Home position switch	
6	X11+0.5	DI+0.5	Digital input 5	Channel 1: Hardware gate			-	
7	X11+0.6	DI+0.6	Digital input 6	Channel 2: Track A / pulse		-	-	
8	X11+0.7	DI+0.7	Digital input 7	Channel 2: Track B / direction		-	-	
9	X11+1.0	DI+1.0	Digital input 8	Channel 2: Hardware gate			-	
10	X11+1.1	DI+1.1	Digital input 9	Channel 3: Track A / pulse		-	-	
11	X11+1.2	DI+1.2	Digital input 10	Channel 3: Track B / direction		-	-	
12	X11+1.3	DI+1.3	Digital input 11	Channel 3: Hardware gate			-	
13	X11+1.4	DI+1.4	Digital input 12	Channel 0: Latch		-	-	
14	X11+1.5	DI+1.5	Digital input 13	Channel 1: Latch		-	-	
15	X11+1.6	DI+1.6	Digital input 14	Channel 2: Latch		-	-	
16	X11+1.7	DI+1.7	Digital input 15	Channel 3: Latch		-	-	

I/O connector X12

For the technological functions, the meaning of the outputs is described in the columns "Counting", "Frequency measurement", "Pulse width modulation", "Analog positioning", and "Digital positioning".

Table 3-6 Pin assignments of I/O connector X12

Pin no.	Pin assignment	Signal/ Address	Description	Counting	Frequency measurement	Pulse width modulation	Positioning	
							Analog	Digital
1	X12+0.0	DO+0.0	Digital output 0		Channel 0: Output		-	-
2	X12+0.1	DO+0.1	Digital output 1		Channel 1: Output		-	-
3	X12+0.2	DO+0.2	Digital output 2		Channel 2: Output		-	-
4	X12+0.3	DO+0.3	Digital output 3		Channel 3: Output		-	-
5	X12+0.4	DO+0.4	Digital output 4		-		-	-
6	X12+0.5	DO+0.5	Digital output 5		-		-	-
7	X12+0.6	DO+0.6	Digital output 6		-		CONV_EN Enable power unit	-
8	X12+0.7	DO+0.7	Digital output 7		-		-	-
9	X12+1.0	DO+1.0	Digital output 8		-		-	Q0
10	X12+1.1	DO+1.1	Digital output 9		-		-	Q1
11	X12+1.2	DO+1.2	Digital output 10		-		-	Q2
12	X12+1.3	DO+1.3	Digital output 11		-		-	Q3
13	X12+1.4	DO+1.4	Digital output 12		-		-	-
14	X12+1.5	DO+1.5	Digital output 13		-		-	-
15	X12+1.6	DO+1.6	Digital output 14		-		-	-
16	X12+1.7	DO+1.7	Digital output 15		-		-	-

I/O connector X13

Table 3-7 Pin assignment of I/O connector X13

Pin no.	Signal	Description
1	AI0-U	Analog voltage input channel 0
2	AI0-I	Analog current input channel 0
3	AI0-C	Analog reference potential channel 0
4	AI1-U	Analog voltage input channel 1
5	AI1-I	Analog current input channel 1
6	AI1-C	Analog reference potential channel 1
7	AI2-U	Analog voltage input channel 2
8	AI2-I	Analog current input channel 2
9	AI2-C	Analog reference potential channel 2
10	AI3-U	Analog voltage input channel 3
11	AI3-I	Analog current input channel 3
12	AI3-C	Analog reference potential channel 3

Pin no.	Signal	Description
13	MANA	Analog ground
14	MANA	Analog ground
15	AIR-P	PT100_OUT
16	AIR-N	PT100_IN

View from right

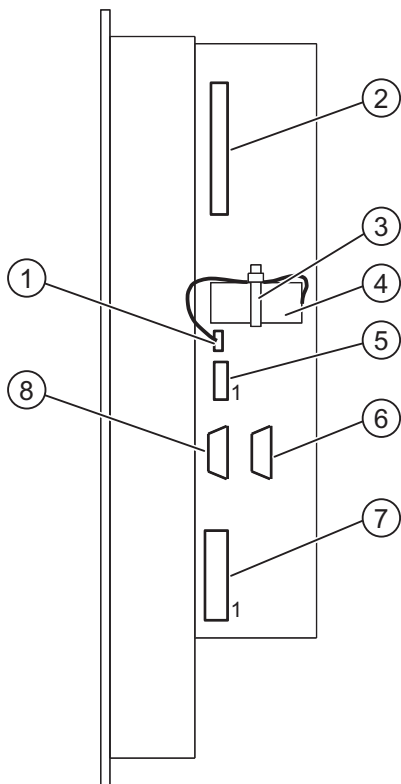

Figure 3-18 C7-636 with plugs and sockets, view from right

- ① X9: Battery plug
- ② X8: Compact Flash Card of the OP
- ③ Cable ty-wrap
- ④ Battery (optional)
- ⑤ X6: USB
- ⑥ X5: Backplane bus (P bus)
- ⑦ X14: Analog output AO2
- ⑧ X4: RS232

RS232 connector X4

Table 3-8 RS232 connector X4

Pin no.	Signal	Description
1	DCD	Received detector
2	RXD	Received data
3	TXD	Transmitted data
4	DTR	Data terminal ready
5	GND	Ground potential 5 V DC
6	DSR	Data set ready
7	RTS	Request to send
8	CTS	Clear to send
9	NC	Not connected

Analog output X14

For the technological functions, the meaning of the outputs is described in the column "Analog positioning".

Table 3-9 Connector pin assignment analog output X14

Pin no.	Signal	Description	Analog positioning
1	AO0_U	Analog voltage output channel 0	Voltage output power unit
2	AO0_I	Analog current output channel 0	Current output power unit
3	MANA	Analog ground	Analog ground
4	AO1_U	Analog voltage output channel 1	-
5	AO1_I	Analog current output channel 1	-
6	MANA	Analog ground	Analog ground

USB interface X6

Table 3-10 Pin assignment of the USB interface X 6

Pin no.	Signal	Description
1	+5 V	Supply voltage 5 V DC
2	USB-DM	DATA -
3	USB DP	DATA +
4	0 V	Ground potential 5 V DC

3.7 Device connections

Device connections of the control system

You can use the following connecting cables to connect the control system to other components:

Table 3-11 Cables for connection to the control system

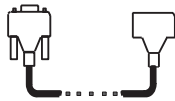
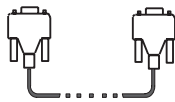
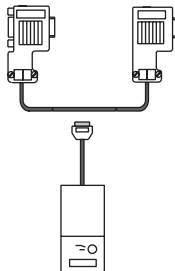
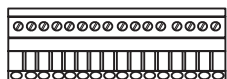
Connecting cables	Length	Special features	Figure	Connection
S7-300 I/O bus				
I/O expansion cable	0.25 m 1.5 m	-		Control system - S7-300 rack
MPI interface				
PG cable	5 m	-		For example: Control system - PG Control system - S7-300 Control system - S7-400
PROFIBUS DP Interface				
PROFIBUS cable <ul style="list-style-type: none"> • Indoor cable • Underground cable Bus connector <ul style="list-style-type: none"> • without PG socket • with PG socket PROFIBUS terminal RS485 <ul style="list-style-type: none"> • with 1.5-m cable • with 3-m cable • with PG socket and 1.5-m cable 	-	Self-made cable		Control system - PG/PC Control system - control system Control system - S7-300 Control system - S7-400
Serial interface (RS232 (V.24))				
Serial cable (printer cable)		See catalog ST80.1		Control system - printer
IM 360/361				
IM 360/361 cable Connecting cable 368				Control system - additional I/O (S7-300)
Connections control system - I/O				
Cable for the connectors of the control system - I/O		16-pin 6-pin 4-pin		Control system - external signal encoder / actuators
Conductor cross-section		0.2 to 2.5 mm ²		

3.8 Guidelines for interference-proof installation

Overview

Automation systems require appropriate shielding measures in order to prevent interference. This can only be ensured by installing the equipment in metal enclosures (in a switching cabinet, for example).

In a system that is not properly bonded to ground or shielded, noise on the internal controller bus may develop as a result of low frequency (LF) or high frequency (HF) signals.

Noise may be emitted from switching relays or contactors (high-speed current or voltage transitions, RF interference), or may develop as a result of equipotential differences between two plant elements (NF interference).

Note

You can find further information on installation guides in the *S7-300, CPU 31XC and CPU 31X: installation* manual.

Notice

Commonly available USB devices usually do not satisfy the higher requirements of industry with respect to noise immunity and may cause negative effects on the control system.

Usage / routing of interference-proof cables

- All analog signal cables must be shielded.
- Always use the standard cables supplied by Siemens.
- Connect both ends of the shielding of the following cables:
 - control signal cables,
 - bus cables,
 - cables for connecting I/O devices.
- Screw-tighten or interlock all connectors.
- Do not route signal cables in parallel to power circuit cables.

Route the signal cables through a separate cable duct, which is installed at a distance of at least 50 cm away from power cables.

Control cabinet installation

Devices, which may introduce external interference to the control cabinet, should be mounted in the bottom area of the cabinet. Always mount the grounding busbar at a position close to the cable inlet, so that you can connect noise-carrying cables directly to earth potential. The shielding of all cables must be terminated on this busbar. Terminate only the outer shielding of cables equipped with double shielding.

Route longer signal cables along the cabinet walls. EMC-compliant cabinet installation is vital in order to reduce disturbance variables. All ground connections of the cabinet must be interconnected by means of cables with a large conductor cross-section, and with appropriate contact to a large area in the cabinet.

Analog devices installed in the control cabinet should be electrically isolated, and bonded at least once to an area in the cabinet by means of a copper braid.

Always use metal materials of the same grading. Never use aluminum, because of the risk of oxidation.

Bond all the doors and sheet metal parts (side wall, back wall and lid) of the cabinet at least at three points to the cabinet frame. Keep these connections as short as possible, ensure the connecting surfaces are free of varnish and are of appropriate size.

Note

In plants generating a high electrostatic discharge level (e.g. in textile processing systems, or particular construction machinery), always connect machine parts which are subject to interference to a separate functional ground, i.e. bond the central grounding busbar of the cabinet to a separate equipotential earth (surface grounding to the building construction, steel reinforcement).

Functional ground

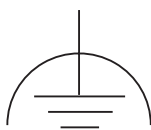

Bond the connection for the functional ground to the cabinet ground using a cable lug and a cable with a minimum conductor cross-section of 4 mm².

3.9 Connecting shielded cables

Overview

This section describes how to connect the shielding of shielded signal lines to earth. Connect to ground using a grounding busbar that directly connects the shielding to the ground of the control system.

Procedure

How to install the grounding busbar and the shielding terminals supplied with the control system:

1. Use the enclosed screws to screw the grounding busbar at the position ① shown in the figure or alternatively at the position ②.
2. Install the shielding terminals on the ground busbar.
3. Push the stripped ends of the cable shielding into the shielding terminals.

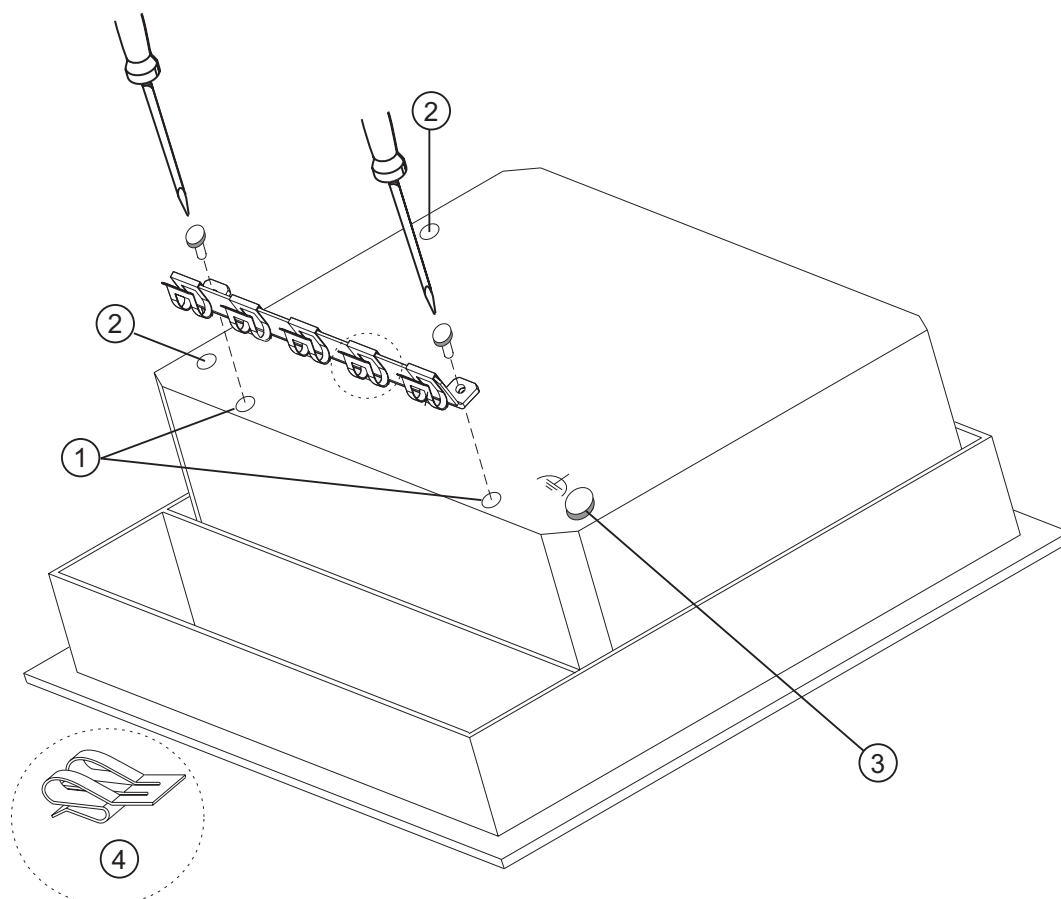

Figure 3-19 Control system with grounding busbar, shielding terminals, and terminal for functional ground

- ① Taps for fastening the grounding busbar
- ② Taps for fastening the grounding busbar
- ③ Connection for the functional ground
- ④ Shielding terminal

3.10 Coding the connector elements to prevent interchanging

Overview

You can order a connector set with coding profiles and coding tabs as an accessory for the control system, or alternatively:

- Screw terminals connector set
Order number: 6ES7635-0AA00-4AA0
- Connector set spring-type terminals
Order number: 6ES7635-0AA00-4BA0



Caution

Property damage can occur.

Your control system may be damaged if you unintentionally interchange the connectors.

You should therefore prevent such interchanges by coding your connectors.

Coding connectors

With the coding profiles ① and the coding tabs ② you can prevent the connectors from being interchanged without loss of a connecting pin.

Procedure:

1. Insert the coding profile ① for the connector element ❶ into the corresponding grooves.
2. Insert the coding tab ② for the basic connector housing ❷ into the corresponding recesses.

A coding profile directly opposing a coding tab prevents you from plugging in the connector element.

The connector element can be easily plugged in when the coding profiles and tab do not oppose each other.

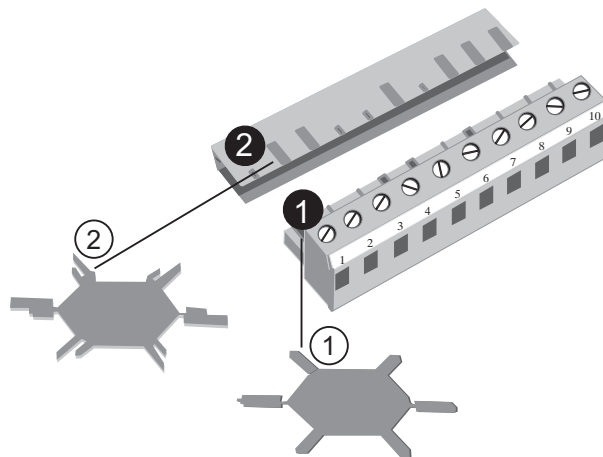

Figure 3-20 How to protect connectors from being interchanged

Special features of the C7-636

4.1 Differences to standard components

Differences to standard components

- Differences from CPU315-2 DP
 - Mode selection
 - I/O sub-modules of the 314C-2 DP CPU
 - Arrangement S7-300 expansion modules
 - Status display of the on-board digital I/O
 - All inputs of the integrated I/O are connected to a common reference ground
- Deviations from TP 270 10" / OP270 6"
 - Without adjustable RS422 interface
 - Without second RS232 interface
 - Without DP interface to **TP/OP**

4.2 Mode selection

Changing the operating mode

The CPU modes RUN, STOP and MRES are selected by means of the mode selector keys:

The status of the CPU changes each time a key is pressed.

The RUN key (upper key) must be held pressed for at least 500 ms for the transition to take place and to light up the relevant LED "R".

The key LEDs (R, S, M) do not indicate the operating state of the CPU, but rather the position of the mode selector keys.

The figure shows the C7-636 Key. The function and position of the operating mode keys and the status and error LEDs are identical in the C7-636 Touch.

4.2 Mode selection

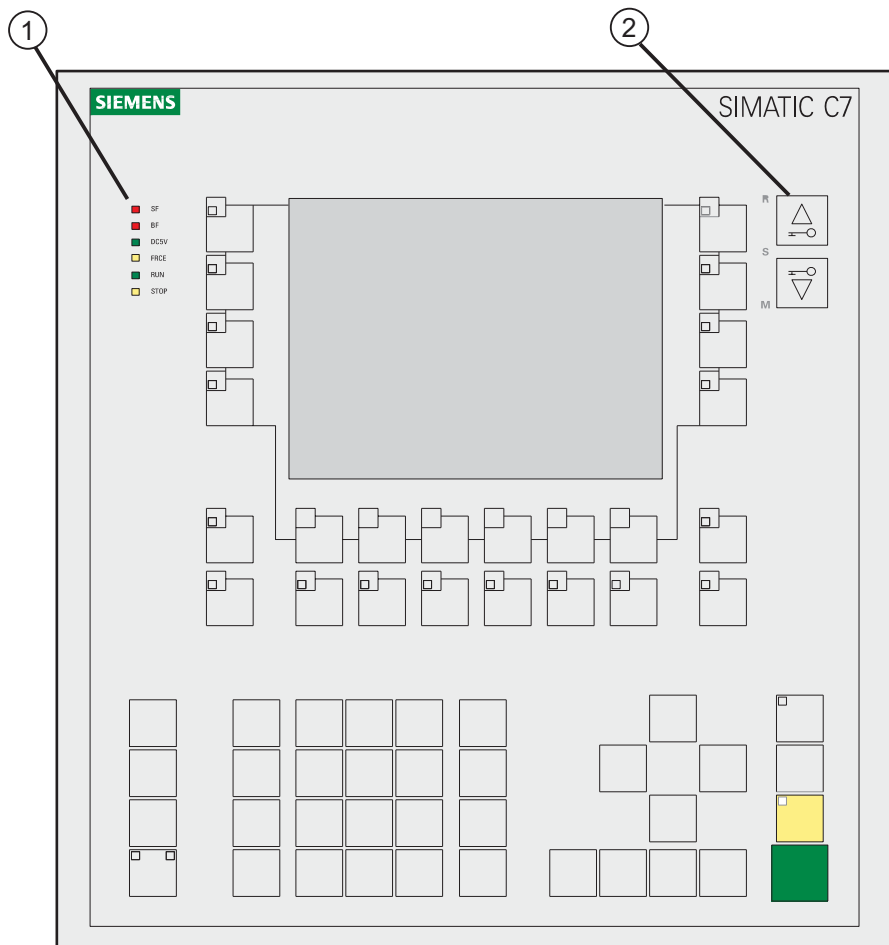





Figure 4-1 C7-636 Key

- ① Status and error LEDs
- ② Mode selector keys with LEDs

Table 4-1 Mode selector keys

Operating mode	Key LEDs	Mode selector keys	Description / procedure
RUN	R		The C7 CPU executes the user program. Programs and data can be <ul style="list-style-type: none"> • uploaded from the C7 CPU to the PG/PC (C7 → PG/PC), • be downloaded to the C7-CPU and can be edited there (PG/PC → C7).
STOP	S		The C7 CPU does not execute user programs. Programs can <ul style="list-style-type: none"> • be uploaded from the C7 CPU to the PG/PC (C7 → PG/PC) • be downloaded to the C7-CPU and can be edited there (PG/PC → C7). <p>Note: The STOP mode applies only to the C7-CPU. It does not apply to the C7-TP/OP. It is always possible to continue working with the C7-TP/OP.</p>
MRES	M	 	CPU memory reset By resetting the memory of the C7-CPU the memory is deleted and the user program reloaded from the MMC.

Influencing the operating mode selection

The key function can be enabled or disabled by means of the external authorization inputs AT1 and AT2, in order to prevent the C7 CPU operating modes from being changed in an uncontrolled manner (for example, by unauthorized operating staff). Hence you can set whether the operating mode selection is possible (activated) or impossible (deactivated).

The authorization inputs are located on the supply connector X1 of the C7-636.

Operating mode selection activated

The operating mode selection is activated if the authorization inputs AT1/AT2 are bridged:

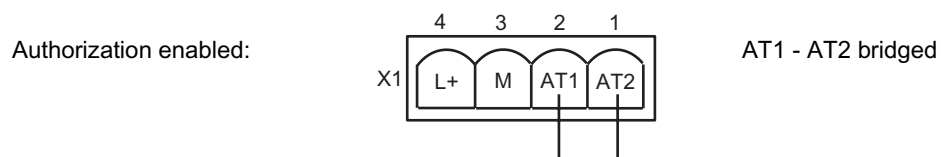

When mode selection is enabled,

- the key LEDs next to the operating mode keys indicate the mode selector setting
- the current CPU operating status is indicated by the status LEDs.

Operating mode selection deactivated

The operating mode selection is deactivated if the authorization inputs AT1/AT2 are open:

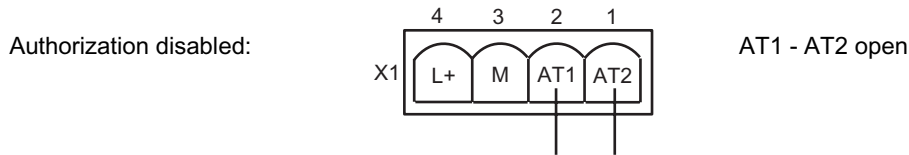

When mode selection is disabled:

- the LEDs next to the mode selector keys are switched off
- the current CPU operating status is indicated by the status LEDs.

4.3 CPU memory reset

Introduction

By resetting the memory of the C7-CPU the memory is deleted and the user program reloaded from the MMC.

CPU memory reset

To reset C7 CPU memory (clears memory, loads the user program again from the MMC), you need to press the mode selector keys in a certain sequence:

1. Select the STOP mode by pressing the DOWN key.
2. The "S" key LED lights up
3. The CPU status LED "STOP" is lit.
4. Select MRES mode by pressing the UP+DOWN key simultaneously. The "M" key LED is lit.
5. Hold the keys down until the "STOP" status LED lights up a second time and until remains lit (this happens after 3 seconds).
6. Release the keys.
7. Within three seconds, press both keys once again simultaneously.
8. Release the keys when the "STOP" status LED flashes rapidly (at 2 Hz).
9. After CPU memory is reset, the "STOP" status LED stops flashing and remains lit. CPU memory is now reset and it is in STOP mode.

You need to perform the steps described in the table above only if you want to reset the memory of your control system, and without the control system itself having requested a memory reset (indicated by slow flashing of the "STOP" status LED). If the control system requests a CPU memory reset, the process can be started by briefly pressing both the UP key and the DOWN key.

In specific situations you may need to reformat your MMC if the control system requests a second memory reset. For information, refer to the *S7-300, CPU 31xC and CPU 31X: Installation* manual.

4.4 Status and error displays of the control system

Meaning of the status and error displays

The status and error displays are explained in the order of their arrangement on the control system.

Display	Description	Descriptions
SF (red)	Group error of the control system	<p>is lit when there are</p> <ul style="list-style-type: none"> • hardware errors • firmware errors • programming errors • Configuration errors • Computing errors • Time-out • I/O errors during internal I/O functions <p>For precise error analysis, use a PG / PC to read the data from the diagnostic buffer. For detailed information on diagnostic buffer data, refer to the STEP 7 Online Help.</p>
BF (red)	Bus error indication	<p>is lit when there are</p> <ul style="list-style-type: none"> • bus errors (physical errors) • DP interface errors
DC5V (green)	5 V DC supply to the control system	is lit if the internal 5 V DC supply is okay.
FRCE (yellow)	Reserved	is lit when a force request is active on the CPU.
RUN (green)	Control system RUN mode	<p>is lit when the control system is executing the user program.</p> <p>flashes (2 Hz) during the control system startup (the STOP indicator is also lit; after this is switched off, the outputs are enabled).</p>
STOP (yellow)	Control system RUN mode	<p>is lit when the control system is executing the user program,</p> <p>flashes slowly when the control system requests a CPU memory reset.</p> <p>flashes quickly when the control system requests a CPU memory reset.</p>

4.5 Arrangement of S7-300 expansion modules

4.5.1 Arrangement of S7-300 expansion modules

S7-300 expansion modules

You can connect up to four extra S7 300 expansion modules to your control system via the S7-300 I/O bus.

There are the following alternatives:

- Connecting a maximum of two S7-300 modules directly to the control system with the "I/O set for 2 modules, set flat"
- Connecting a maximum of four S7-300 modules directly to the control system with the "I/O set for 4 modules, set deep"
- Connecting a maximum of four S7-300 modules at a distance of maximum 1.5 m with the aid of the I/O expansion cable 1.5 m and an S7 standard profile rail of the S7-300 automation system.

You may install an IM-360 interface module to connect further modules.

For information on the installation of S7-300 modules, refer to the *S7 300, CPU 31xC and 31x: Installation* manual.

4.5.2 Connecting a maximum of two S7-300 modules directly to the C7-636

Requirements

- The "I/O set for 2 modules, set flat".
- You have taken into account the necessary mounting depth:

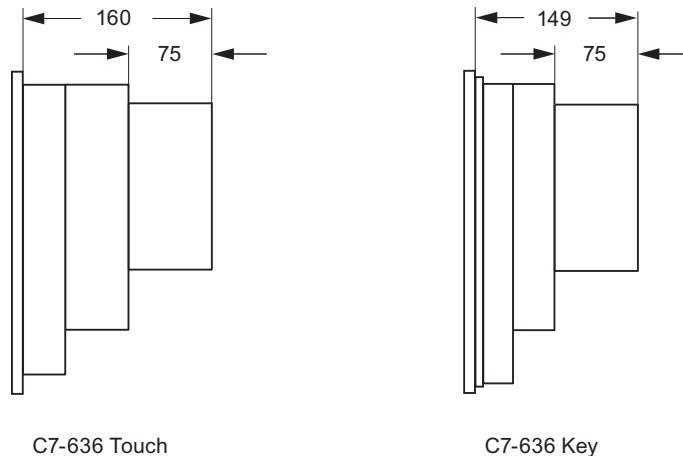

Figure 4-2 Mounting depth of the I/O set for 2 modules, set flat (dimensions in mm)

Connect

1. Screw the mounting panel to the back wall of the enclosure.
2. Install the control system in the cabinet door. Follow the instructions in chapter "Mechanical installation".
3. Connect the control system to the module (inserted on the left in the figure) using the connecting cable (0.25 m).
4. Connect the two modules using the connecting cable (0.08m).
5. Mount the modules on the S7 profile rail.

The following photograph shows the C7-636 Key. With C7-636 Touch the mounting of the I/O set is identical.

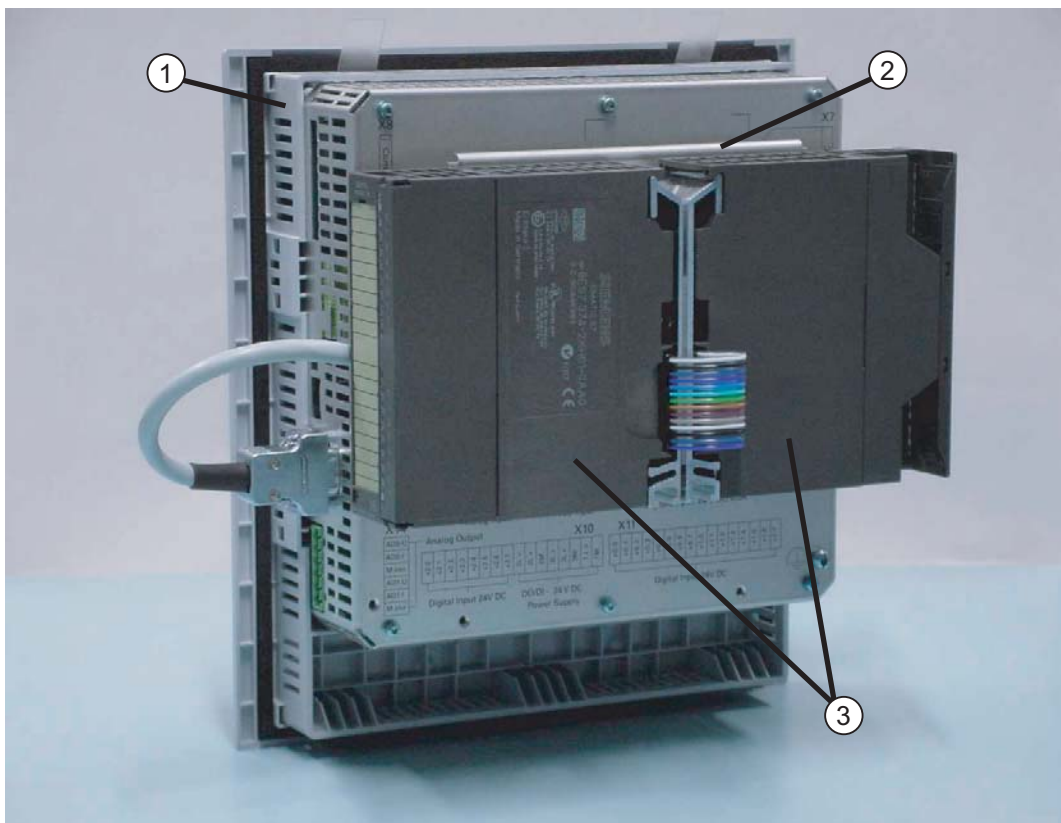

Figure 4-3 Connecting S7-300 expansion modules directly to the device using the 2-module I/O set

- ① Control system
- ② Mounting panel
- ③ S7-300 modules

4.5.3 Connecting a maximum of four S7-300 modules directly to the control system

Requirements

- The "I/O set for 4 modules, set deep".
- You have taken into account the necessary mounting depth:

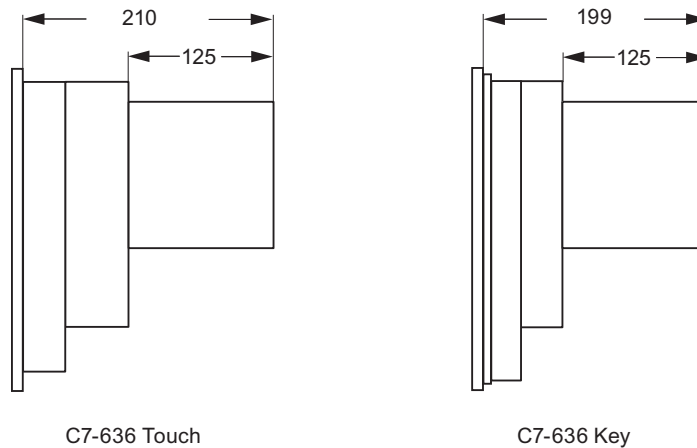

Figure 4-4 Mounting depth of the I/O set for 4 modules, set deep (dimensions in mm)

Connect

1. Screw the S7 profile rail (190 mm) onto the backplane of the housing.
2. Install the control system in the cabinet door. Follow the instructions in chapter "Mechanical installation".
3. Connect the control system to the module on the extreme left using the connecting cable.
4. Mount the modules on the S7 profile rail (190 mm).

The following photograph shows the C7-636 Key. With C7-636 Touch the mounting of the I/O set is identical.

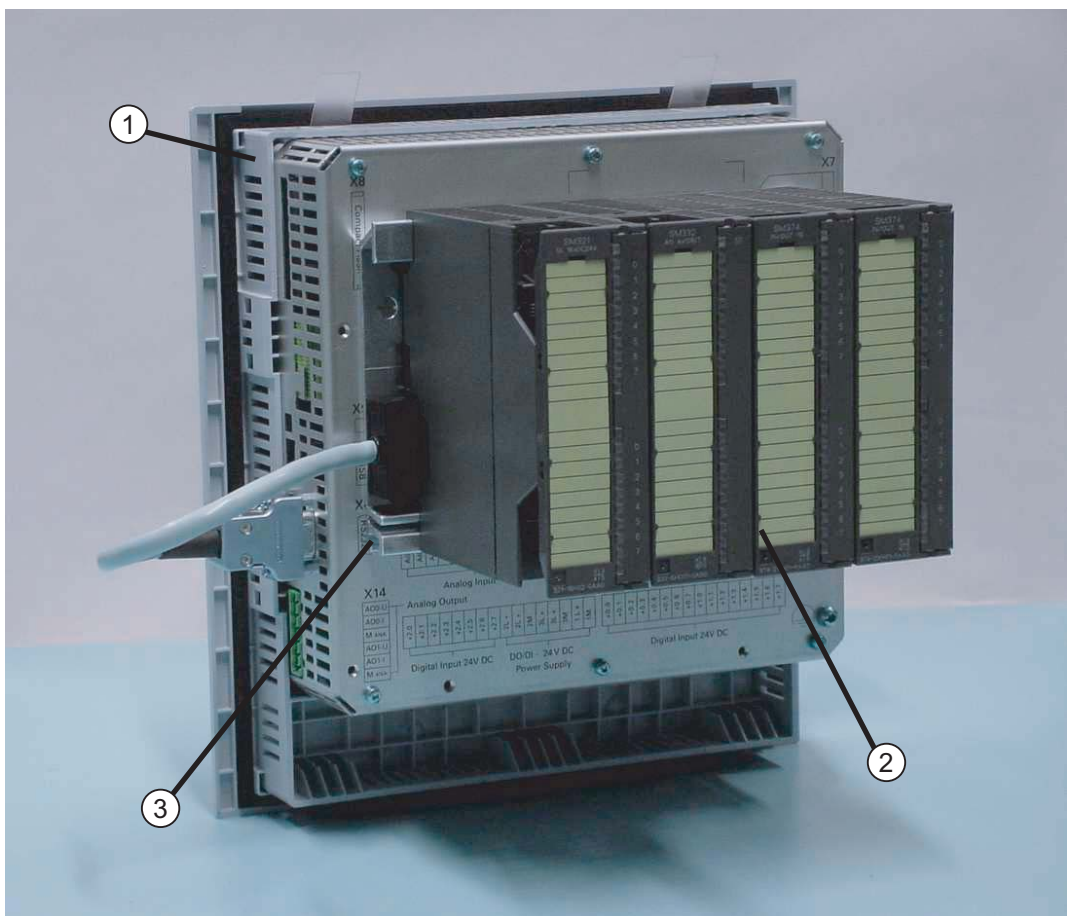

Figure 4-5 Connecting S7-300 expansion modules directly to the device using the 4-module I/O set

- ① Control system
- ② S7-300 modules
- ③ S7 profile rail

4.5.4 Connecting a maximum of four S7-300 modules at a distance of max. 1.5 m

Requirements

The "I/O expansion cable, 1.5 m" and a S7 standard profile rail of the S7-300 automation system is available.

Connect

1. Connect the control system to the module on the extreme left using the "I/O expansion cable, 1.5 m".
2. Mount the modules on a standard profile rail of the S7-300 automation system.
3. Using the cable clamp, connect the shielding of the I/O expansion cable to the S7 profile rail.

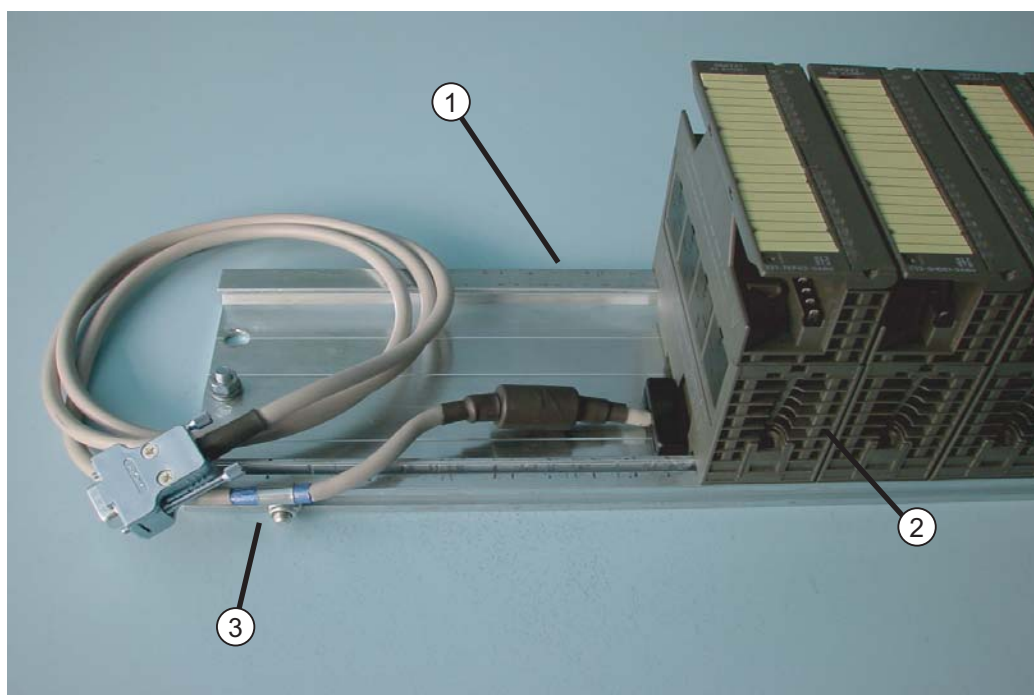

Figure 4-6 Connecting S7-300 expansion modules at a distance of up to 1.5 m

- ① S7 profile rail
- ② S7-300 module
- ③ Cable clamp for the shielding

4.6 Status display of the on-board digital I/O

I/O status display

There are no LEDs for indicating the status of the control system I/O. To display the status, you can configure an I/O status view:

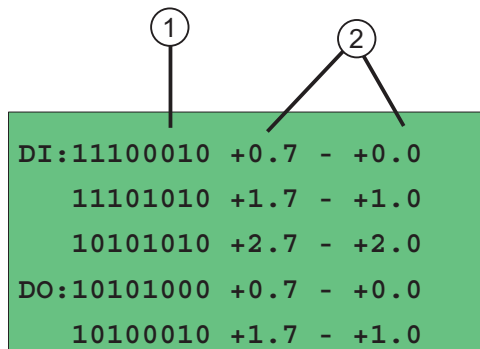

Figure 4-7 DI/DO status display

The visualized values must be read as a direct **process image** of the DI and an internal process image of the DO of the digital control system I/O, and displayed in BIN format.

Note that when the C7 CPU is in STOP, the physical process status DO is 0. However, the last process status set by the program is displayed.

The following data are displayed:

Table 4-2 Description of the DI/DO status display

Item	Description
①	Signal status of the DI/DO <ul style="list-style-type: none"> • 1 = DI/DO set • 0 = DI/DO reset
②	DI/DO pin designation

Note

The values of the DI/DO display are updated within the time configured in ProTool. Intermediate values are not displayed.

Maintenance

The control system is designed for low maintenance operation. Maintenance is required only in the following areas:

- Cleaning of the display at regular intervals
- Replacement of the optional backup battery
- Replacement of a faulty device

5.1 Cleaning the display

Preparation

Switch off the device before you clean the display. This ensures that you do not unintentionally delete functions.

Cleaning agent

Use only water and soft detergents or a foam screen cleaning agent.

Note

Aggressive solutions or abrasive detergents may strip the keyboard membrane or damage the display.

Cleaning screen

If the cleaning screen function is configured in your project, during the time shown on the running bar you can clean the display of the C7-636 Touch whilst it is still running, without triggering any unintentional functions. All entries are blocked during this time.

Protective film

A protective film is available for the C7-636 Touch. The foil prevents the display from getting scratched or soiled.

Cleaning the display

Clean the display of your device at regular intervals using a damp cloth.

Spray the cleaning solution onto the cloth, rather than directly onto the monitor.

5.2 Replacing the optional backup battery

Source of supply

The battery should be ordered from the Siemens spare parts department. The battery is supplied ready for installation, including the cable and plug. The order number is found in our *ST80* catalog.

Before you replace it

Before you replace the battery, read the following safety-relevant information:



Caution

Always replace the battery when power is on, in order to ensure continuous operation of the hardware clock.

The battery may only be changed by qualified personnel.

Refer to the EC guidelines on battery replacement.

Replacing the backup battery

1. Pull the battery supply plug out of the pin strip X9 of the control system.
2. The battery is fastened to the side of the enclosure by means of a ty-wrap. Cut off this ty-wrap, for example using a side-cutter, then remove the used battery.
3. Use a cable ty-wrap to fasten the battery at the punched recess in the sheet metal enclosure.
4. Plug the battery connector into pin strip X9 again. The connector is coded for protection against polarity reversal.

Safety-relevant information

Note the following safety-relevant information on proper handling and disposal of lithium batteries:

**Warning**

Improper usage may cause an explosion of the lithium battery.

The batteries

- may not be charged,
- may not be opened,
- may not be short-circuited,
- may not be operated with reversed polarity,
- may not be heated up above 100 °C,
- must be protected from direct sunlight.

Dewing may not develop on batteries.

If transportation is required, the hazardous goods regulations for the relevant carrier must be complied with (mandatory identification of goods.)

Used up lithium batteries belong to the hazardous waste category. They must be packaged in seal-tight plastic disposal bags.

5.3 Replacing the C7-636

5.3.1 Replacing the control system

Introduction

A control system is not designed for on-site repair. Hence, a defective control system must be replaced.

Please note

a Compact Flash Card (CF card) should be available for backing up the TP/OP configuration data. You should generate a backup copy of the configuration on the CF card as soon as you have finished commissioning the device, so that you can restore the configuration if the device becomes defective.

Caution

The CF card protrudes from the control system and could be damaged when you remove the device.

Prior to the removal and installation of the device, remove the Micro Memory Card (MMC) and the Compact Flash Card (CF Card).

Caution

The backup battery must be loosened before you remove the control system.
Refer to chapter "Replacing the backup battery".

How you proceed depends on whether you have backed up the TP/OP configuration on a CF Card.

5.3.2 Dismantling a control system with CF card

Requirements

- You have inserted a CF card.

Dismantling

1. Backup your TP/OP configuration data on the CF card (Backup). You should generate the backup copy immediately before you remove the device in order to include the current data (such as recipes). For information on how to create a backup copy, refer to the *Multi Panel MP 270 B, Touch Panel TP 270, Operator Panel OP 270* manual.
2. You do not need to explicitly backup the user program of the CPU. It is saved as a non-volatile program on the MMC.
3. Switch on the power supply.
4. Loosen the cables from the shielding terminals and remove all connectors.
5. Remove the MMC and the CF Card.
6. Loosen the optional backup battery.
7. Loosen the brackets with a screw driver, then remove the device from the control cabinet.
8. Only with C7-636 Key: Remove the sealing from the upper part of the enclosure.

5.3.3 Installing a control system with CF card

Requirements

- Backup your TP/OP configuration data on the CF card.
- Only with C7-636 Key: A new sealing is available. The sealing must always be replaced when you replace the C7-636 Key. The sealing is a constituent part of the service package.

Installation

1. Only with C7-636 Key: Carefully press the new sealing into the groove of the upper enclosure element.
2. Install the control system as described in chapter "Mechanical installation". Be sure to observe the relevant notes.
3. Insert the MMC and the CF Card.
4. Fasten the optional backup battery.
5. Insert the cable and push the cable shielding into the shielding terminals.
6. Switch on the power supply.
7. Restore the backed up TP/OP configuration data to the internal memory (Restore). For information, refer to the *Multi Panel MP 270 B*, *Touch Panel TP 270*, *Operator Panel OP 270* manual.
8. Reset C7 CPU memory.
9. Switch the CPU to RUN.

5.3.4 Dismantling a control system without CF card

Requirements

- PG / PC with MPI interface
- MPI connection cable
- ProTool

Dismantling

1. Connect a PG / PC to the MPI interface.
2. Generate a backup copy of the TP/OP configuration data in the control system using ProTool. If the control system is defective and the configuration cannot be read, remove the control system without taking any further safety measures.
3. You do not need to explicitly backup the user program of the CPU. It is saved as a non-volatile program on the MMC.
4. Switch on the power supply.
5. Loosen the cables from the shielding terminals and remove all connectors.
6. Remove the MMC.
7. Loosen the optional backup battery.
8. Loosen the brackets with a screw driver, then remove the device from the control cabinet.
9. Only with C7-636 Key: Remove the sealing from the upper part of the enclosure.

5.3.5 Installing a control system without CF card

Requirements

- PG / PC with MPI interface
- MPI connection cable
- ProTool
- Remove the sealing from the upper part of the enclosure.
- Only with C7-636 Key: A new sealing is available. The sealing must always be replaced when you replace the C7-636 Key. The sealing is a constituent part of the service package.

Installation

1. Only with C7-636 Key: Carefully press the new sealing into the groove of the upper enclosure element.
2. Install the control system as described in chapter "Mechanical installation". Be sure to observe the relevant notes.
3. Insert the MMC.
4. Fasten the optional backup battery.
5. Insert the cable and push the cable shielding into the shielding terminals.
6. Switch on the power supply.
7. Connect the control system to the MPI interface of the PG / PC.
8. Make sure that the MPI interface is enabled in "Transfer > Transfer Settings" of the "Control Panel" dialog box.
9. Enable transfer mode and download the backed-up TP/OP configuration data using ProTool.
10. Reset C7 CPU memory.
11. Switch the CPU to RUN.

Technical data

6.1 Overall technical data of the device

Table 6-1 Technical data of the C7-636

Overall technical data of the device	C7-636 Touch	C7-636 Key
General data		
Order number	6ES7636-2EB00-0AE3	6ES7636-2EC00-0AE3
Dimensions	335 x 275 x 100 mm (W x H x D)	260 x 274 x 80 mm (W x H x D)
Mounting dimensions	310 x 248 mm (tolerance: +1 mm)	231 x 257 mm (tolerance: +1 mm)
Mounting depth of the 2-module I/O set:	160 mm	149 mm
	(measured from outer edge of sheet metal cut-out)	
Mounting depth of the 4-module I/O set:	210 mm	199 mm
	(measured from outer edge of sheet metal cut-out)	
Weight	3,980 g	1,750 g
Software		
TP/OP operating system platform	MS Windows CE	
Color display		
Type	CSTN-LCD with Touch	CSTN-LCD
Active screen, diagonal	10,4 "	5,7 "
Resolution (pixels)	640 x 480 (VGA)	320 x 240 (QVGA)
Color resolution	256	256
Background lighting	CCFL tubes	CCFL tubes
Half Brightness Life (Duty time expiring until the luminance of the tube has reached only 50 % of its original value. The specified value depends on the operating temperature.)	60000 h	40000 h
Keyboard		
Type	Membrane keyboard	Membrane keyboard
Mode selector key	2	2
System keys with fixed functions	–	36 (3 with LED)

Technical data

6.1 Overall technical data of the device

Overall technical data of the device	C7-636 Touch	C7-636 Key
Configurable function keys <ul style="list-style-type: none"> • Number • of those available as softkeys • labeling 	– – –	24 (18 with LED) 14 plant-specific with labeling strips
Power supply		
Supply voltage (V_n)	24 V DC; (20.4 V DC to 28.8 V DC, safety extra-low voltage SELV) The C7-636 is not protected against high-energy interference pulses in the μ s-range (surge pulse). For information on relevant safety regulations, refer to the <i>S7 300 Programmable Controller: CPU 31xC and 31x</i> manual.	
• Polarity reversal-protected input voltage	Yes	
• Polarity reversal-protection of digital input supply voltage	Yes	
• Polarity reversal-protection of digital output supply voltage	No	
• Voltage interruption (can be buffered)	≥ 20 ms	
Current consumption		
• typically when idle	0.65 A	0.45 A
• maximum	1.5 A	1.3A
Inrush current	3 A for 10 ms, then 2 A for 70 ms	
Power dissipation (maximum)	24 W	19 W
Ungrounded installation	Not possible	
Backup battery (optional)		
Type	Lithium battery (Sonnenschein SL2361)	
Voltage / capacity (Technical changes reserved)	3.6 V / approx. 1.5 Ah	
Service life	approx. 4 years	
Safety		
Standard references	DIN EN 61131–2 corresponds to IEC 61131–2	
Protection against ingress of foreign matter and water <ul style="list-style-type: none"> • Front panel • Housing 	IP65, to IEC 60529, NEMA 4X IP20, to IEC 60529	
Electromagnetic compatibility (EMC)		
Noise emission Limit class	A, to EN55011	
Cable-fed disturbances on DC supply cables	± 2 kV (to IEC 61000-4-4; burst) Surge measurements with additional protective elements: ± 1 kV (to IEC 61000-4-5; μ s-pulse/cable to cable) ± 2 kV (to IEC 61000-4-5; μ s-pulse/cable to ground)	
Noise immunity on signal cables	± 2 kV (to IEC 61000-4-4; burst)	
Immunity against static discharges	± 6 kV, contact discharge (in accordance with IEC 61000-4-2; ESD) ± 8 kV, contact discharge (in accordance with IEC 61000-4-2; ESD)	

6.1 Overall technical data of the device

Overall technical data of the device	C7-636 Touch	C7-636 Key
Radio frequency-proof	10 V/m	with 80 % amplitude modulation at 1 kHz,
	10 V/m	with 80 % amplitude modulation at 1 kHz, 80 MHz to 1 GHz and 1.4 GHz to 2 GHz (in accordance with IEC 61000-4-3)
	10 V/m	pulse-modulated 50% ED with 900 MHz and 1.89 GHz (in accordance with IEC61000-4-3)
Climatic conditions		
Temperature	Tested in accordance with IEC 60068-2-1, IEC 60068-2-2:	
<ul style="list-style-type: none"> • Operation 	0 °C to +40 °C in horizontal mounting position 0 °C to +45 °C with 45° mounting position 0 °C to +50 °C in vertical mounting position	
<ul style="list-style-type: none"> • Storage/transport 	-20 °C to +60 °C	
Relative humidity	Tested in accordance with IEC 60068-2-3	
<ul style="list-style-type: none"> • Operation • Storage/transport 	5% to 85% at 40 °C (no dewing) 5% to 85% at 40 °C (no dewing)	
Barometric pressure		
<ul style="list-style-type: none"> • Operation • Storage/transport 	1080–795 hPa (in accordance with -1000 m to +2000 m) 1080–660 hPa (in accordance with -1000 m to +3,500 m)	
Mechanical environmental conditions		
Vibration	Tested in accordance with IEC 60068-2-6	
<ul style="list-style-type: none"> • Operation 	10 Hz to 58 Hz, amplitude 0.075 mm 58 Hz to 150 Hz, acceleration 9.8 m/s ²	
<ul style="list-style-type: none"> • Storage/transport in packaging 	5 Hz to 9 Hz, amplitude 3.5 mm 9 Hz to 500 Hz, acceleration 9.8 m/s ²	
Shock test	Tested in accordance with IEC 60068-2-29	
<ul style="list-style-type: none"> • Operation • Storage/transport 	Half-sine: 150 m/s ² (15g), 11 ms, 18 shocks 250 m/s ² (25 g), 6 ms, 1000 shocks	
Fireproofing:		
<ul style="list-style-type: none"> • Terminal strips • Master strips in housing 	FV2 (tested in accordance with IEC 60707) FV0	

6.2 Technical data TP/OP

Technical data TP/OP

The table below summarizes the functionality of the TP/OP of the C7-636. The values provided for HMI functions are maximum values that can be managed by the C7-636. These values are limited by the size of the internal configuration memory, or the size of the Compact Flash Card (CF Card).

Table 6-2 TP/OP scope of functions

Function		C7-636 Touch (TP)	C7-636 Key (OP)
Memory	TP/OP configuration	2 MB	
	Recipes	64 KB internal, expandable by means of Compact Flash Card (CF card)	
Messages	Number	4000	
	Display	Message line/box/display	
	Viewing all pending messages	Message page / message display	
	Length of message text	70 characters (font-specific) for message texts configurable in ProTool, 255 characters (font-specific) for message texts configurable in Step7	
	Process values in message text	8	
	Message states identified in different colors	Yes	
	Operational messages	Yes	
	Error messages <ul style="list-style-type: none"> • Display mode • Acknowledgement of individual error messages • Group error acknowledgement 	Yes First/last, selectable yes 16 acknowledgement groups	
Alarm_S	S7 messages shown	Yes	
Message logging	Output to printer	Yes	
Volatile message buffer	Message buffer capacity	512 message events	
	Messages viewed	Yes	
	Deleting	Yes	
	Printing	Yes	
	Maximum number of queued message events <ul style="list-style-type: none"> • Operational messages • Error messages / ALARM_S 	500 250	
Message buffer log	Storage location	File	
	Capacity	Limited by memory media (PC card, CF card, network drive)	
Message logging	Event time	Date/time	
	Message event	Incoming, outgoing, acknowledged	

	Function	C7-636 Touch (TP)	C7-636 Key (OP)
Screens	Number	300	
	Fields per screen	200	
	Variables per screen	200	
	Complex elements per screen (trends, bar graphs etc.)	10	
	Displays	Yes	Yes
	Printing (hard copy)	Yes	Yes
	Screen objects		
	• Text	Yes	Yes
	• Images	Yes	Yes
	• Output box	Yes	Yes
	• Input box	Yes	Yes
	• Symbolic output box	Yes	Yes
	• Selection box	Yes	Yes
	• Date/time	Yes	Yes
	• Graphic display	Yes	Yes
	• Image list	Yes	Yes
	• Image selection list	Yes	Yes
	• Button	Yes	Yes
	• Status button	Yes	Yes
	• Status area	Yes	Yes
	• Switch	Yes	Yes
• Hidden switch	Yes	Yes	
• Trend display	Yes	Yes	
• Bar graph	Yes	Yes	
• Message display	Yes	Yes	
• Simple message display	Yes	Yes	
• Status / control	Yes	Yes	
• Password list	Yes	Yes	
• Recipe display	Yes	Yes	
• Slider	Yes	Yes	
• Analog display	Yes	Yes	
• Digital clock / analog clock	Yes	Yes	
• SIMATIC HMI symbol library	Yes	Yes	
Menu-controlled			
• Help text	Yes	Yes	
• Dynamic attributes	Yes	Yes	
• Show / hide objects	Yes	Yes	
• Pictograms for softkeys	-	Yes	
• TAB sequence	-	Yes	
• LEDs in function keys	-	Yes	
Permanent window	Yes	Yes	
Variables	Number	2048	
Limit-value monitoring	Input / output	Yes	Yes
Conversion functions	Input / output	Yes	Yes

	Function	C7-636 Touch (TP)	C7-636 Key (OP)
Help text	Lines / characters	7 / 35 (font-specific)	
	for messages	Yes	Yes
	for images	Yes	Yes
	for screen objects		
	• Input box	Yes	Yes
	• Selection box	Yes	Yes
	• Button	-	Yes
	• Status button	-	Yes
	• Switch	-	Yes
	• Hidden button	-	Yes
Logging	Messages	Yes	
	Variables	Yes	
	Log type	Continuous / event log	
	Number of log files	20	
	Maximum number of recordable variables	20	
	Number of event logs	40	
	Entries per log file	10000	
	Storage location	File (CSV)	
Lists	Number	500	
	Image lists	400	
	Text lists	500	
Print functions	Screenshot hardcopy also in color	Yes	
	Direct message logging	Yes	
	Layer protocol	Yes	
Password protection	Number of passwords	50	
	Password level	10 (0 to 9)	
Recipes	Number	300	
	Data records per recipe (limited by memory media PC card, CF card, network drive)	500	
	Entries per recipe	1000	
Online languages	Number of languages	5	
PG functions (Status/control)	SIMATIC S5	Yes	
	SIMATIC S7	Yes	
Screen settings	Screen blanking	Yes	
	Luminance	Yes	
	Screen saver	Yes	
	Contrast	Yes	
	Touch calibration	Yes	-
Watchdogs	Trigger functions, cyclically or one-shot	Yes	

	Function	C7-636 Touch (TP)	C7-636 Key (OP)
VB script	User-specific enhancements of functionality	Yes	
	Number of scripts	50	
	Number of lines per script	20	
Connections (with SIMATIC S7)	Number	6	

6.3 Technical data of the CPU

Table 6-3 Technical data of the CPU

Memory	
RAM	
• Integrated	128 KB
• Expandable	No
Load memory	Plug-in (MMC)
Backup	Ensured with MMC (maintenance-free)
Execution times	
• Bit operation	0.1 μ s
• Word instructions	0.2 μ s
• Fixed-point maths	2 μ s
• Floating-point maths	6 μ s
Timers / counters and their retentivity	
S7 counters	256
• Retentivity	Adjustable
• Default	From C 0 to C 7
• Counting range	0 to 999
IEC Counters	Yes
• Type	SFB
• Number	Unlimited (limited only by work memory)
S7 timers	256
• Retentivity	Adjustable
• Default	Non-retentive
• Timer range	10 ms to 9990 s
IEC timers	Yes
• Type	SFB
• Number	Unlimited (limited only by work memory)
Data areas and their retentivity	
Total retentive data area (including flags, timers, counters)	All
Flags	2048 bytes
• Retentivity	Yes
• Default retentivity	MB 0 to MB 15
Clock memory	8 (1 flag byte)
Data blocks	Max. 1023
• Size	Max. 16 KB
Local data per priority class	Max. 1024 bytes, max. 510 bytes per block

Blocks	
OBs	See instruction list
• Size	Max. 16 KB
Nesting depth	
• Per priority class	8
• Additional nesting depth within one error OB	4
FBs	Max. 2048
• Size	Max. 16 KB
FCs	Max. 2048
• Size	Max. 16 KB
Address areas (I/Os)	
Total I/O address area	Max. 2048
• Of those distributed	Max. 2000 bytes
I/O process image	128 bytes / 128 bytes
Digital channels	Max. 16384
• Of those local	Max. 992
• Integrated channels	24 DI / 16 DO
Analog channels	Max. 1024
• Of those local	Max. 248
• Integrated channels	4 + 1 AI / 2 AO
Configuration	
Rack	Max. 4
Modules in rack 0	Max. 4
Modules in rack 1 and 2	Max. 8
Modules in rack 3	Max. 7
Number of DP masters	
• Integrated	1
• by means of CP	Max. 1
Function modules and communication processors that can be operated	
• FM	Max. 8
• CP (PtP)	Max. 8
• CP (LAN)	Max. 10
Time-of-day	
Real-time clock	Yes (HW clock)
• Buffered	Yes
• Backup period	6 weeks, typically (at an ambient temperature of 40°C)
• Accuracy	Deviation per day < 10 s
Operating hours counter	1
• Number	0
• Range of values	0 to 2 ³¹ hours (when using SFC 101)
• Resolution	1 hour
• Retentive	Yes; must be restarted each time there is a cold restart

6.3 Technical data of the CPU

TOD synchronization	Yes
• In AS	Master
• On MPI	Master / slave
S7 Message functions	
Number of stations that can log in for message functions (for example, OS)	Max. 16
Process diagnostic messages	Yes
• Simultaneously active interrupt S blocks	Max. 40
Testing and commissioning functions	
Status / control variables	Yes
• Variables	Inputs, outputs, flags, DBs, timers, counters
• Number of variables	Max. 30
– Of those as status variable	Max. 30
– Of those as control variables	Max. 14
Force	Yes
• Variables	Inputs, outputs
• Number of variables	Max. 10
Block status	Yes
Single sequence	Yes
Breakpoint	2
Diagnostic buffer	Yes
• Number of entries (not configurable)	Max. 100
Communication functions	
PG / OP communication	Yes
Global data communication	Yes
• Number of global data packets	Max. 8
– Transmitter	Max. 8
– Receiver	Max. 8
• Size of global data packets	Max. 22 bytes
– Of those are consistent	22 bytes
S7 standard communication	Yes
• User data per job	Max. 76 bytes
– Of those are consistent	76 bytes (with X_SEND or X_RCV) 64 bytes (with X_PUT or X_GET as server)
S7 communication	
• As server	Yes
• As client	Yes (by means of CP and loadable FB)
• User data per job	Max. 180 bytes (with PUT/GET)
– Of those are consistent	64 bytes
S5-compatible communication	yes (by means of CP and loadable FC)
Standard communication	No

Number of connections usable for:	Max. 16
<ul style="list-style-type: none"> • PG communication <ul style="list-style-type: none"> – Reserved (default) 1 – Adjustable From 1 to 15 	Max. 15
<ul style="list-style-type: none"> • OP communication <ul style="list-style-type: none"> – Reserved (default) 1 – Adjustable From 1 to 15 	Max. 15
<ul style="list-style-type: none"> • S7 standard communication <ul style="list-style-type: none"> – Reserved (default) 12 – Adjustable From 0 to 12 	Yes
Routing	Yes
MPI	
Type of interface	Integrated RS485
Physics	RS485
Galvanic isolation	No
Interface power supply (DC 15 V to DC 30 V)	Max. 200 mA
Number of connections	16
Services	
• PG / OP communication	Yes
• Routing	Yes
• Global data communication	Yes
• S7 standard communication	Yes
<ul style="list-style-type: none"> • S7 communication <ul style="list-style-type: none"> – As server Yes – As client Yes (by means of CP and loadable FB) 	
• Transmission rates	Max. 187.5 kbps
PROFIBUS DP	
Type of interface	Integrated RS485
Physics	RS485
Galvanic isolation	Yes
Interface power supply (15 V DC to 30 V DC)	Max. 200 mA
Number of connections	16
DP master	
Number of connections	16
Services	
• PG / OP communication	Yes
• Routing	Yes
• Global data communication	No
• S7 standard communication	No
• S7 communication	No
• Constant bus cycle time	Yes

6.3 Technical data of the CPU

• SYNC/FREEZE	Yes
• Enable / disable DP slaves	Yes
• Transmission rates	Up to 12 Mbps
• Number of DP slaves per station	Max. 125
• Address area	Max. 244 bytes
DP slave	
Number of connections	16
Services	
• PG / OP communication	Yes
• Routing	yes (only with active interface)
• Global data communication	No
• S7 standard communication	No
• S7 communication	No
• Direct data exchange	Yes
• Transmission rates	Up to 12 Mbps
• Transfer memory	244 bytes I / 244 bytes O
• Address areas	Maximum 32, with maximum 32 bytes each
Programming	
Programming language	LAD / FBD / STL
Instruction set	See instruction list
Nesting levels	8
System functions (SFCs)	See instruction list
System function blocks (SFBs)	See instruction list
User program protection	Yes
Integrated I/O	
Default addresses	
• Digital inputs	124.0 to 126.7
• Digital outputs	124.0 to 125.7
• Analog inputs	752 to 761
• Analog outputs	752 to 755
Integrated functions (cf. the <i>S7-300 PLCs, CPU31xC technological functions</i>) manual	
Counters, frequency counters, pulse outputs (pulse width modulation)	4 channels in total, Frequency counter up to 60 kHz Pulse outputs up to 2.5 kHz
Controlled positioning	1 channel
Integrated "Control" SFB	PID controller

6.4 Technical data of integrated I/O

Technical data of integrated I/O

The following tables include the technical data for the integrated I/O, structured according to:

- Digital inputs
- Digital outputs
- Analog inputs
- Analog outputs

Digital inputs

Table 6-4 Digital inputs

Number	
Number of inputs	24
• of those available for technological functions	16
Cable length	
• Non-shielded	
– For standard DI	Max. 600 m
– Technological functions	non-shielded cables not allowed
• Shielded	
– For standard DI	Max. 1,000 m
– Technological functions	Max. 50 m (at max. counter frequency)
Voltage, currents, potentials	
Rated load voltage L+	24 V DC
• Polarity reversal protection	Yes
Number of inputs that can be triggered simultaneously	
• Vertical mounting position	
– Up to 40 °C	18
– Up to 50 °C	12
• 45 ° mounting position	
– Up to 45 °C	12
• Horizontal mounting position	
– Up to 40 °C	12
Galvanic isolation	
• Between channels and P-bus	Yes
• Between channels	No
Permissible potential difference	
• Between different circuits	75 V DC / 60 V AC
Insulation tested at	500 V DC
Power consumption from load voltage L+ (without load)	Max. 70 mA

6.4 Technical data of integrated I/O

Status, interrupts, diagnostics	
Interrupts	<ul style="list-style-type: none"> • Yes, if the corresponding channel is configured as an interrupt input • When using the technological functions, cf. <i>S7-300 Programmable Controller, CPU31xC Technological Functions</i> manual
Diagnostic functions	<ul style="list-style-type: none"> • No diagnostics when operated as standard I/O • When using the technological functions, cf. <i>"S7-300 Programmable Controller, CPU31xC Technological Functions"</i> manual
Data for selecting an encoder for standard DIs	
Input voltage	
<ul style="list-style-type: none"> • Rated value 	24 V DC
<ul style="list-style-type: none"> • for signal "1" 	15 V to 30 V
<ul style="list-style-type: none"> • for signal "0" 	-3 V to 5 V
Input current	
<ul style="list-style-type: none"> • with signal "1" 	7 mA, typically
Delay of standard inputs	
<ul style="list-style-type: none"> • Configurable 	Yes (0.1 ms/ 0.5 ms/ 3 ms/ 15 ms) You may change the delay time of standard inputs while the program is being executed. Please note that your new filter time may not be effective until the next filter cycle.
<ul style="list-style-type: none"> • Rated value 	3 ms
Input delay when using technological functions	
<ul style="list-style-type: none"> • Minimum pulse width / minimum pulse interval at maximum count frequency 	8 µs
Input characteristic	to IEC 1131, Type 1
Connection of 2-wire BEROs	Possible
<ul style="list-style-type: none"> • Permissible quiescent current 	Max. 1.5 mA

Digital outputs

Note

Technological functions utilize the high-speed digital outputs. These outputs may only be connected to resistive loads.

Table 6-5 Digital outputs

Number	
Number of outputs	16
• Of those are high-speed outputs	4
Cable length	
• Non-shielded	Max. 600 m
• Shielded	Max. 1,000 m
Voltage, currents, potentials	
Rated load voltage L+	24 V DC
• Polarity reversal protection	Yes
Accumulated output current (per group)	
• Vertical mounting position	
– Up to 40 °C	Max. 3.0 A
– Up to 50 °C	Max. 2.0 A
• 45 °mounting position	
– Up to 45°C	Max. 2.0 A
• Horizontal mounting position	
– Up to 40 °C	Max. 2.0 A
Galvanic isolation	
• Between channels and P-bus	Yes
• Between channels	Yes
– In groups of	8
Permissible potential difference between different circuits	75 V DC / 60 V AC
Insulation tested at	500 V DC
Current consumption from load voltage L+	Max. 20 mA per group
Status, interrupts, diagnostics	
Interrupts	<ul style="list-style-type: none"> • No interrupts when operated as standard I/O • When using the technological functions, cf. <i>S7-300 Programmable Controller, CPU31xC Technological Functions manual</i>
Diagnostic functions	<ul style="list-style-type: none"> • No diagnostics when operated as standard I/O • When using the technological functions, cf. <i>S7-300 Programmable Controller, CPU31xC Technological Functions manual</i>

6.4 Technical data of integrated I/O

Data for selecting an actuator for standard DOs	
Output voltage	
• with signal "1"	Min. L+ (-0.8 V)
Output current	
• with signal "1"	0.5 A
– Rated value	5 mA to 600 mA
– Permissible range	
• For "0" signal (residual current)	Max. 0.5 mA
Load resistance range	48 Ω to 4 kΩ
Lamp load	Max. 5 W
Parallel connection of 2 outputs	
• for redundant load control	Possible
• For increasing power	Not possible
Digital input control	Possible
Switching frequency	
• with ohmic load	Max. 100 Hz
• with inductive load to IEC 947-5, DC13	Max. 0.5 Hz
• with lamp load	Max. 100 Hz
• High-speed outputs with resistive load	Max. 2.5 kHz
Inductive shut-down voltage limited internally to	(L+) - 48 V, typically
Short-circuit protected output	Yes, electronic
• Response threshold	1 A, typically

Analog inputs

Table 6-6 Analog inputs

Number	
Number of inputs	
<ul style="list-style-type: none"> • Current / voltage input • Resistance input 	4 channels 1 channel
Cable length	
<ul style="list-style-type: none"> • Shielded 	Max. 100 m
Voltage, currents, potentials	
Resistance input	
<ul style="list-style-type: none"> • No-load voltage • Measurement current 	Typically 2.5 V 1.8 mA to 3.3 mA, typically
Galvanic isolation	
<ul style="list-style-type: none"> • Between channels and P-bus • Between channels 	Yes No
Permissible potential difference	
<ul style="list-style-type: none"> • Between inputs and M_{ANA} (V_{CM}) • between M_{ANA} and $M_{internal}$ (U_{ISO}) 	8.0 V DC 75 V DC / 60 V AC
Insulation tested at	500 V DC
Analog value generation	
Measuring principle	Actual value encoding (successive approximation)
Integration time / conversion time / resolution (per channel)	
<ul style="list-style-type: none"> • Configurable • Integration time in ms • Permissible input frequency • Resolution (incl. overshoot range) • Interference suppression at interference frequency f_1 	Yes 2,5 / 16,6 / 20 Max. 400 Hz 11 bits + sign bit 400 / 60 / 50 Hz
Time-base of input filter	0.38 ms
Basic execution time	1 ms
Interference suppression, error limits	
Interference suppression at $f = n \times (f_1 \pm 1 \%)$ ($f_1 =$ interference frequency), $n = 1, 2$	
<ul style="list-style-type: none"> • Common mode interference ($V_{CM} < 8.0$ V) • Push-pull interference (Peak value of the interference < rated value of the input range) 	> 40 dB > 30 dB
Crosstalk between inputs	>50 dB (at $V_{CM} = 0$ V)
Operational error limit (across the temperature range, relative to input range)	
<ul style="list-style-type: none"> • Voltage / current • Resistance 	<1 % <5 %

Technical data

6.4 Technical data of integrated I/O

Basic error limits (operational error limit at 25 °C, relative to input range)	
• Voltage / current	<0,7 %
• Resistance	<3 %
Temperature error (relative to input range)	±0.006 %/K
Linearity error (relative to input range)	±0,06 %
Accuracy of reproducibility (in transient state at 25 °C, relative to input range)	±0,06 %
Status, interrupts, diagnostics	
Interrupts	<ul style="list-style-type: none"> No interrupts when operated as standard I/O When using the technological functions, cf. <i>S7-300 Programmable Controller, CPU31xC Technological Functions manual</i>
Diagnostic functions	<ul style="list-style-type: none"> No diagnostics when operated as standard I/O When using the technological functions, cf. <i>S7-300 Programmable Controller, CPU31xC Technological Functions manual</i>
Encoder selection data	
Input ranges (rated values)/input resistance	
• Voltage	±10 V / 100 kΩ 0 V to 10 V / 100 kΩ
• Current	±20 mA / 50 Ω 0 mA to 20 mA / 50 Ω 4 mA to 20 mA / 50 Ω
• Resistance	0 Ω to 600 Ω/10 MΩ
• Resistive thermocouple	Pt 100 / 10 MΩ
Permissible input voltage (destruction limit)	
• at voltage input	Maximum 30 V continuous;
• at current input	Max. 2.5 V continuous, max. 24 V transient
Permissible input current (destruction limit)	
• at voltage input	Max. 0.5 mA continuous
• at current input	Max. 50 mA continuous
Connection of signal encoders	
• for voltage measurement	Possible
• for current measurement – as 2-wire measuring transducer – as 4-wire measuring transducer	possible with external power supply Possible
• for measuring resistance – with 2-wire connection – with 3-wire connection – with 4-wire connection	Possible, without cable resistance compensation Not possible Not possible

Linearization of characteristic curve	By software
• For resistive thermocouples	Pt 100
Temperature compensation	No
Technical unit for temperature measurement	Degrees Centigrade / Fahrenheit / Kelvin

Analog outputs

Table 6-7 Analog outputs

Number	
Number of outputs	2
Cable length	
Shielded cable length	Max. 200 m
Voltage, currents, potentials	
Rated load voltage L+	24 V DC
• Polarity reversal protection	Yes
Galvanic isolation	
• Between channels and P-bus	Yes
• Between channels	No
Permissible potential difference	
• between M _{ANA} and M _{internal} (U _{ISO})	75 V DC / 60 V AC
Insulation tested at	500 V DC
Analog value generation	
Resolution (incl. overshoot range)	11 bits + sign bit
Conversion time (per channel)	1 ms
Settling time	
• resistive load	0.6 ms
• capacitive load	1.0 ms
• inductive load	0.5 ms
Interference suppression, error limits	
Crosstalk between outputs	> 60 dB
Operational error limit (across the temperature range, relative to output range)	
• Voltage / current	±1 %
Basic error limits (operational error limit at 25 °C, relative to output range)	
• Voltage / current	±0,7 %
Temperature error (relative to output range)	±0.01 %/K
Linearity error (relative to output range)	±0,15 %
Accuracy of reproducibility (in transient state at 25 °C, relative to output range)	±0,06 %

6.4 Technical data of integrated I/O

Output ripple, bandwidth 0 to 50 kHz (relative to output range)	±0,1 %
Status, interrupts, diagnostics	
Interrupts	<ul style="list-style-type: none"> No interrupts when operated as standard I/O When using the technological functions, cf. <i>S7-300 Programmable Controller, CPU31xC Technological Functions manual</i>
Diagnostic functions	<ul style="list-style-type: none"> No diagnostics when operated as standard I/O When using the technological functions, cf. <i>S7-300 Programmable Controller, CPU31xC Technological Functions manual</i>
Data for selecting an actuator	
Output range (rated values)	
• Voltage	±10 V 0 V to 10 V
• Current	±20 mA 0 mA to 20 mA 4 mA to 20 mA
Load resistance (in the rated range of the output)	
• Voltage outputs – ohmic load – capacitive load	min. 1 kΩ Maximum 0.1 μF
• Current outputs – ohmic load – inductive load	Maximum 300 Ω max. 0.1 mH
Voltage output	
• Short-circuit protection	Yes
• Short-circuit current	55 mA, typically
Current output	
• No-load voltage	Typically 17 V
Destruction limit for externally applied voltages / currents	
• Output voltage to M _{ANA}	Maximum 16 V continuous;
• Current	Max. 50 mA continuous
Connection of actuators	
• For voltage output – 2-wire connection – 4-wire connection (measuring cable)	Possible, without cable resistance compensation Not possible
• For current output – 2-wire connection	Possible

6.5 Notes on the power supply

24 V DC power supply

For the C7-636, the entire 24 V DC power supply has to be generated (operating voltage, load voltage, relay supply, etc.) as Safety Extra-Low Voltage (SELV).



Warning

Personal injury and property damage can occur.

A faulty configuration of your 24 V DC power supply may damage the components of your automation system or lead to injury.

For the 24 V DC power supply of the C7-636, use only safety extra-low voltage (SELV).

6.6 Approvals

Approvals

There are the following approvals for the C7-636:

- Approvals for USA and Canada
- FM Approval
- Marine approval

Approvals for USA and Canada

Note

Which one of the approvals (UL/CSA or cULus) listed below is relevant for your product is indicated on the rating plate.

UL approval



Underwriters Laboratories Inc. to

- UL 508 (Industrial Control Equipment)

CSA approval



Canadian Standards Association to

- C22.2 No. 142 (Process Control Equipment)

or



Underwriters Laboratories Inc. to

- UL 508 (Industrial Control Equipment)
- CSA C22.2 No. 142 (Process Control Equipment)

or



Underwriters Laboratories Inc. to

- UL 508 (Industrial Control Equipment)
- CSA C22.2 No. 142 (Process Control Equipment)
- UL 1604 (Hazardous Location)
- CSA-213 (Hazardous Location)

APPROVED for use in

Class I, Division 2, Group A, B, C, D Tx;

Class I, Zone 2, Group IIC Tx

FM Approval



FM-Standards No. 3611, 3600, 3810 APPROVED for use in Class I, Division 2, Group A, B, C, D indoor hazardous locations.



Warning

Personal injury and property damage can occur.

In a potentially explosive environment, there is a risk of personal injury and damage to material if you disconnect a connector while the system is in operation.

In a potentially explosive environment, always switch off power to the C7-636 before you disconnect any connectors.



Warning

WARNING - DO NOT DISCONNECT WHILE CIRCUIT IS LIVE UNLESS LOCATION IS KNOWN TO BE NON-HAZARDOUS

Marine approval

Approvals by the following classification authorities are pending:

- ABS (American Bureau of Shipping)
- BV (Bureau Veritas)
- DNV (Det Norske Veritas)
- GL (Germanischer Lloyd)
- LRS (Lloyds Register of Shipping)
- Class NK (Nippon Kaiji Kyokai)

6.7 Notes on the CE Label

EC Guideline 89/336/EEC EMC Guidelines



This product complies with the requirements of the EC guideline 89/336/EEC "Electromagnetic Compatibility."

The EC declarations of conformity and their associated documentation are available for the competent authorities in accordance with the above-mentioned EC Guideline, Article 10 (1) at the following address:

Siemens Aktiengesellschaft

Automation technology

A&D AS RD 4

PO box 1963

D-92209 Amberg

Range of Application

The following range of application applies for the control system, in accordance with this CE label:

Range of Application	Requirements	
	Noise emission	Noise immunity
Industrial applications	EN 50081-2: 1993	EN 61000-6-2: 1999

Note the installation guidelines

The installation guidelines and safety notes provided in the documentation are to be adhered to during commissioning and operation.

6.8 Notes for machine manufacturers

Please note

The SIMATIC automation system is not a machine in the sense of the EC "Machinery" guideline. Consequently, no declaration of conformity exists with respect to EC guideline 89/392/EEC "Machinery."

EC Guideline 89/392/EEC "Machinery"

EC Guideline 89/392/EEC "Machinery" regulates the requirements of machinery. In this guideline, machinery is considered to include all associated parts or mechanisms (cf. EN 292-1, Section 3.1).

SIMATIC is a part of the electrical equipment of a machine and must therefore be included by the machine manufacturer in the declaration of conformity.

Electrical equipment of machinery in accordance with EN 60204

The standard EN 60204-1 (Safety of Machinery, General Requirements of the Electrical Equipment of Machinery) is applicable for the electrical equipment of machinery.

The following table is provided to help you with the declaration of conformity; it indicates which criteria are applicable to SIMATIC in accordance with EN 60204-1 (June 1993 edition).

EN 60204-1	Subject / criterion	Comments
Section 4	General requirements	The requirements are satisfied if the devices are mounted/installed in accordance with the installation guidelines. You must also take into account the explanations provided on previous pages.
Section 11.2	Digital I/O interfaces	The requirements are satisfied.
Section 12.3	Programmable equipment	The requirements are satisfied if devices for protection against changes to memory by unauthorized persons are installed in lockable cabinets.
Section 20.4	Dielectric Tests	The requirements are satisfied.

6.9 Technical support

SIMATIC Technical Support

You can reach the Technical Support for all A&D products

- Via the Internet with the **Support Request:**
<http://www.siemens.com/automation/support-request>
- Per e-mail: adsupport@siemens.com
- Telephone: +49 (0) 180 5050 222
- Fax: +49 (0) 180 5050 223

You'll find more information regarding our Technical Support via the Internet under
<http://www.siemens.com/automation/service>

Service & Support on the Internet

In addition to our documentation packages, we also offer you a complete knowledge base on the Internet.

<http://www.siemens.com/automation/service&support>

There you will find:

- Our Newsletter with the latest information on your products
- Documentation suitable for your needs, which can be obtained using our Search engine in Service & Support.
- A forum where users and specialists exchange information on a global basis.
- Your local partner for Automation & Drives.
- Information about on-site services, repairs and spare parts Additional information is provided under "Services".

Additional Support

If you have questions regarding the products described in this manual and are unable to find an answer here, please contact your nearest Siemens representative.

Your local contact partner is found under:

<http://www.siemens.com/automation/partner>

The guide for technical documentation for the individual SIMATIC products and systems is located under:

<http://www.siemens.de/simatic-tech-doku-portal>

The online catalog and the online order system can be found under:

<http://mall.ad.siemens.com/>

Training Center

To make it easier for you to get started, we are offering suitable courses. Please contact your regional training center or the central training center in -90327 Nuremberg/Germany.

Phone: +49 (911) 895 -3200

<http://www.sitrain.com>

Index

A

- Accessories, 2-10
- Analog output, 3-25
- Approval
 - CSA, 6-22
 - Marine, 6-23
 - UL, 6-22
- Approvals, 6-21
- Arrangement of S7-300 expansion modules
 - at a maximum distance of 1.5 m, 4-11
 - directly on the device, 4-7
- Authorization inputs AT1/AT2, 4-3

B

- Background lighting
 - Screen, 6-1
- Backup, 5-4
- Backup battery, 6-2
- Battery, 6-2
- BF, 4-5
- Bottom view, 3-21
- Brackets, 2-10
- Bus connector, 3-26

C

- C7-636
 - Accessories, 2-10
 - Bottom view, 3-21
 - Front view, 3-16
 - installation, 3-6
 - Options, 2-9
 - Rear view, 3-17
 - View from left, 3-19
 - View from right, 3-24
 - what you need for operating, 2-9
- Cable 1.5 m, 2-10
- Cables
 - interference-proof installation, 3-27
- Capacity
 - Backup battery, 6-2

- CE label, 6-21, 6-24
- Cleaning agent, 5-1
- Coding connectors, 3-30
 - coding profile, 3-30
- Color display, 6-1
- Colors, 6-1
- components
 - necessary for operation, 2-9
- Components, 2-4
- Connecting cable 368, 3-26
- Connecting cables, 3-26
- Connecting shielded cables, 3-28
- Connector coding, 3-30
- Connector pin assignment, 3-15
 - Imprint, 3-18
- Connector set
 - Screw terminals, 2-9, 3-30
 - Spring-type terminals, 2-9, 3-30
- Control cabinet installation, 3-28
- CPU memory reset
 - MRES, 4-3
- CSA
 - Approval, 6-22
- Current consumption, 6-2

D

- Degree of protection IP65/NEMA 4X, 3-4
- Dewing, 3-5
- DI/DO status display, 4-12
- Differences from CPU315-2 DP, 4-1
- Differences from OP 270 6, 4-1
- Digital input, 3-21, 3-22, 3-23
- Digital output, 3-23
- Dimensions, 6-1
- Display
 - cleaning, 5-1
- Documentation package, iv

E

- EC guideline
 - Machinery, 6-25
- Error displays, 4-5

F

FM Approval, 6-23
FRCE, 4-5
Functional ground, 3-28

G

Grounding, 3-27, 3-28
Grounding busbar, 3-28
 installation, 3-29
 with shielding terminals, 2-10
Group error
 CPU, 4-5

H

Hotline, 6-26

I

I/O connector
 Analog output, 3-25
 Digital input, 3-21, 3-22
 Digital output, 3-23
 supply voltage, 3-21
I/O expansion, 2-5
 at a maximum distance of 1.5 m, 4-11
 directly on the device: I/O set for 2 modules, 4-7
 directly on the device: I/O set for 4 modules, 4-9
I/O set
 2 modules, 2-9
 4 modules, 2-10, 4-9
I/O status display, 4-12
IM360 / 361 cable, 3-26
Installation
 interference-proof, 3-27
Installation C7-636, 3-6
Installation guidelines, 3-27
Integrated I/O, 2-6
Interfaces, 2-4
Interference signals, 3-27
Interference-proof installation, 3-27
Internet, 6-26

K

Key LEDs, 4-1
Keyboard, 6-1

L

Labeling strips, 3-1
Labeling the function keys, 3-1
Lithium battery, 6-2

M

Machinery
 with SIMATIC, 6-25
Maintenance, 5-1
Manufacturers of machines, 6-25
Marine
 Approval, 6-23
Mechanical installation, 3-4
Membrane keyboard, 6-1
Mode selection, 4-1
Mode selector keys, 4-1
Mounting depth, 6-1
 2-module I/O set, 6-1
 4-module I/O set, 6-1
MPI address, 2-8
MPI cable, 2-10
MPI connection, 3-20
MRES, 4-3

N

Notes on the power supply, 6-21

O

Operating the C7-636
 what you need, 2-9
Options, 2-9
Order number
 C7,636, iii

P

PC adapter, 2-10
PG cable, 3-26
PG connection, 3-20
Plug, 3-16
Power supply, 6-2, 6-21
Power supply connector, 3-19
PROFIBUS DP
 Bus cable, 3-26
 Bus terminal, 3-26
 interface, 2-7
PROFIBUS DP connection, 3-20

R

RAM, 2-6
Rear view, 3-17
Replacing the C7-636, 5-3
Resolution
 Display, 6-1
Restore, 5-5
RS232 connection, 3-25
RUN, 4-3, 4-5

S

S7-300 expansion modules, 4-6
S7-300 modules, 4-6
Scope of delivery, 2-8
Screen diagonal, 6-1
Sealing, 2-10
Service, 6-26
SF, 4-5
Shielding, 3-27
Shielding terminal, 3-29
SIMATIC Customer Support Hotline, 6-26
Sockets, 3-16
Spare parts, 2-10
Status displays, 4-5
Status LEDs, 4-4
STOP, 4-3, 4-5
Sunlight, 3-5
Support, 6-26

T

Technical data
 CPU, 6-8
 Integrated I/O, 6-13
 OP, 6-4
 overall, 6-1
Technological functions, 2-7
Training Center, 6-27

U

UL
 Approval, 6-22
Ungrounded installation, 3-15
USB interface, 3-25

V

View from left, 3-19
View from right, 3-24

W

Weight, 6-1

Device Manual C7-613 Control System

Device Manual C7-635 Control System

Device Manual C7-636 Control System

This product information contains important information about the documentation mentioned above. It is to be regarded as a separate component. Its specifications and information have a higher binding nature than those of other manuals, instruction lists and Getting Starteds.

New C7 devices with larger working memory

The working memory of the following C7 devices was extended. The CPUs can now execute larger user programs.

Due to these improvements, the order number of the CPUs were changed.

The new C7 devices are:

- contained in STEP7 V5.4 Service Pack 1
- configurable with the older STEP7 versions:
The C7 devices with the new order number can be downloaded from the Internet as a hardware update (0109).
Requirement is STEP7 V5.2, Service Pack1.
- configurable with the corresponding previous C7 devices
- compatible with the previous C7 devices

Non-retentive data blocks

In opposition to the data in the S7-300, CPU 31xC and CPU 31x manual, Technical data", chapter 4.1.2, the C7 devices with firmware V2.0.12 are no longer supported by retentive data blocks. Non-retentive data blocks and code blocks can be loaded to the maximum limit of the working memory. Retentive data blocks can be loaded to the maximum retentive limit of the working memory (see the following table).

Product description	Previous order nr.	Firmware <	Previous Working memory	Previous Working memory retentive **	New order nr.	Firmware ≙	Working memory new	Working memory retentive ** new	Hard-ware update
C7-613	6ES7613-1CA01-0AE3	V2.0.12	48 KB	48 KB	6ES7613-1CA02-0AE3	V2.0.12	80 KB	64 KB	0109
C7-635 Touch	6ES7635-2EB01-0AE3	V2.0.12	64 KB	64 KB	6ES7635-2EB02-0AE3	V2.0.12	96 KB	64 KB	0109
C7-635 Key	6ES7635-2EC01-0AE3	V2.0.12	64 KB	64 KB	6ES7635-2EC02-0AE3	V2.0.12	96 KB	64 KB	0109
C7-636 Touch*	6ES7636-2EB00-0AE3	V2.0.12	128 KB	128 KB	6ES7636-2EB00-0AE3	V2.0.12	128 KB	128 KB	-
C7-636 Key*	6ES7636-2EC00-0AE3	V2.0.12	128 KB	128 KB	6ES7636-2EC00-0AE3	V2.0.12	128 KB	128 KB	-

* not affected by the extension of the memory

** Maximum size for retentive working memory for retentive data blocks