

SIEMENS

Product Information

Release 02.2004

RS 485-IS Coupler (6ES7 972-0AC80-0XA0)

This Product Information contains important information concerning the *"ET 200iS Distribute I/O Station"* Manual, order no. 6ES7 151-2AA00-8BA0. Its is to be understood as separate part of the documentation, and in case of any uncertainty overrides all other information in manuals and catalogs.

Special information

This product information refers to PROFIBUS RS 485-IS, and includes a description of PROFIBUS DP Ex i.

Differences between PROFIBUS RS 485-IS and PROFIBUS DP Ex i are documented separately.

Chapter overview

Chapter	Topic	Page
1	Function	2
2	Features	4
3	Installation / Removal	6
4	Wiring	8
5	Commissioning	18
6	Diagnostics	18
7	Maximum configuration	19
8	Technical Specifications	20
9	Order Numbers	25
10	Certifications	25

1 Function

The RS 485-IS Coupler converts PROFIBUS-DP to PROFIBUS RS 485-IS with intrinsic safety (intrinsic safety ignition type i). The RS 485-IS coupler operates here as a safety barrier. IS stands for "Intrinsically Safe".

Fields of application

The RS 485-IS Coupler is used to isolate the intrinsically safe PROFIBUS RS 485-IS from PROFIBUS-DP which is not intrinsically safe.

Note

You may connect to the RS 485-IS Coupler:

- Up to 31 stations (Field Devices RS 485-IS) with PROFIBUS RS 485-IS interface,

or

- Up to 16 stations (ET 200iS stations) with PROFIBUS DP Ex i interface.

Mixed mode within the same segment is not permitted!

Structure

- You need an RS 485-IS Coupler in order to be able to operate RS 485-IS field devices or an ET 200iS in potentially explosive atmospheres (see [1] and [2]).
- You need two RS 485-IS Couplers to amplify data signals on the bus and couple bus segments (see [3]).

The repeater function by means of two RS 485-IS Couplers is required:

- When the number of stations operated in the Ex area exceeds the approved number
 - When the maximum cable length is exceeded at a segment in the Ex area
 - To couple a PROFIBUS RS 485-IS segment to a PROFIBUS DP Ex i segment
- The RS 485-IS Coupler also allows you to connect devices to PROFIBUS RS 485-IS which can be operated only in Zone 2, e.g. operating panels (see [4]).

Note

The internal bus terminator of the RS 485 IS Coupler must be switched on for operation on PROFIBUS DP Ex i. Looping of PROFIBUS DP Ex i is not permitted (see [2])!

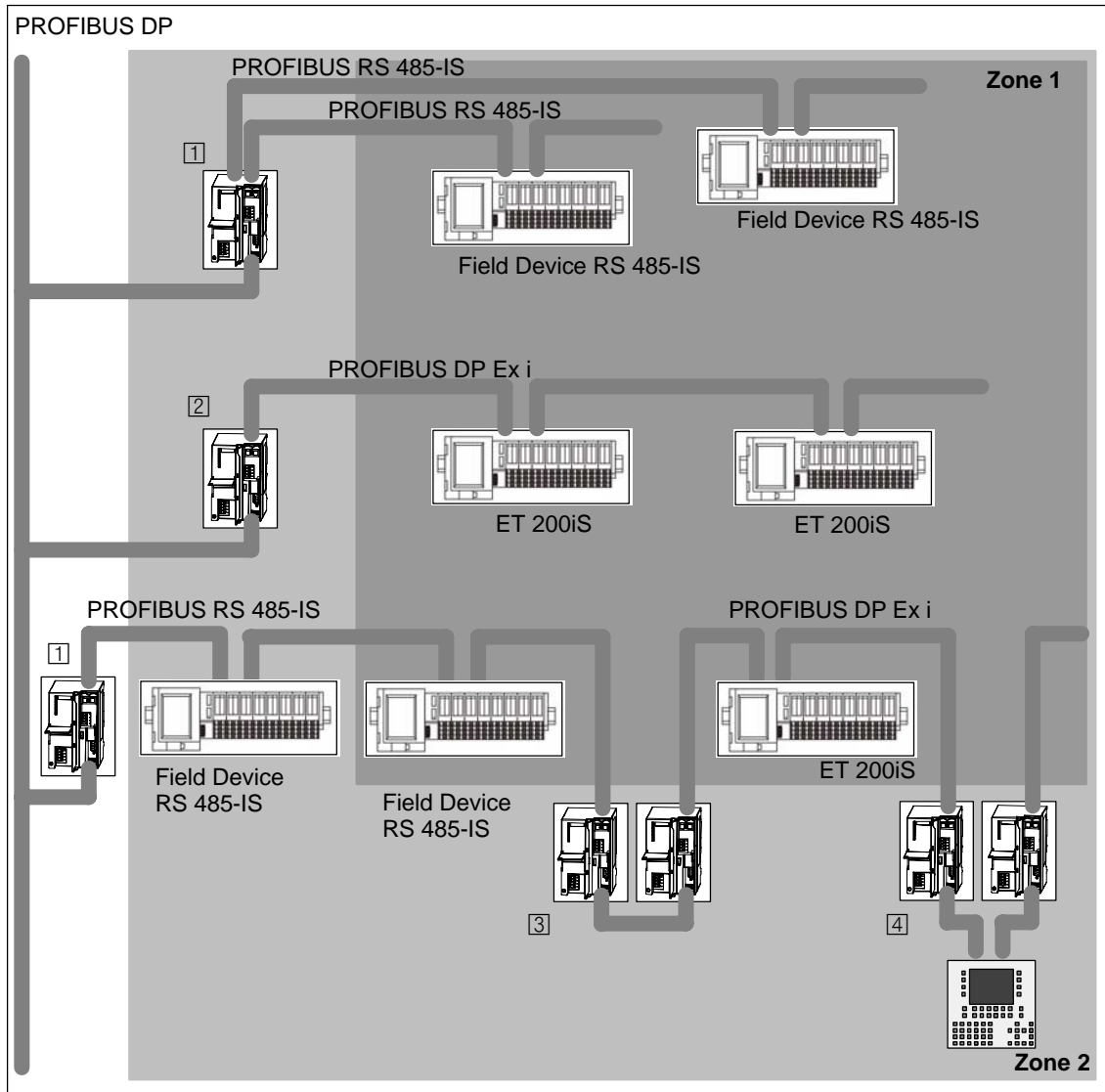

Figure 1 RS 485-IS Coupler Fields of Application

2 Features

Structure

View of the RS 485-IS Coupler:

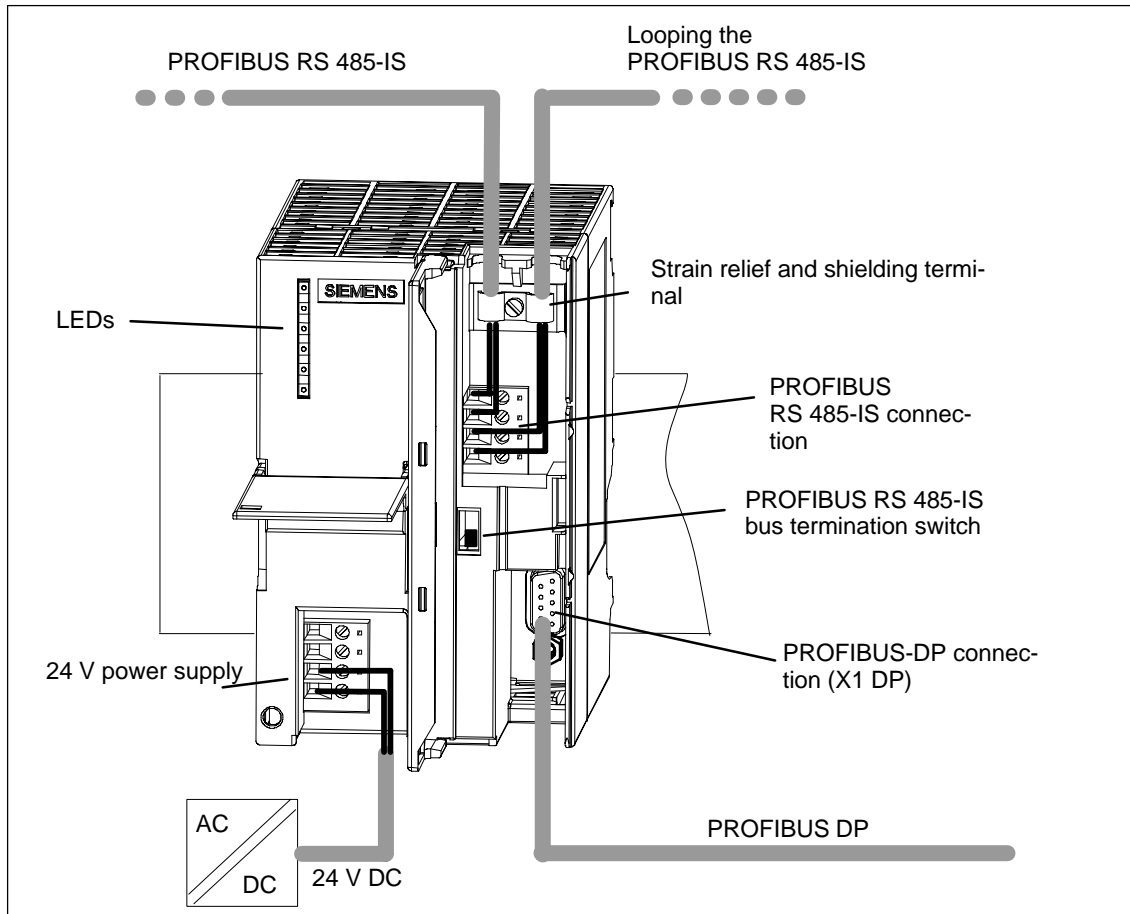

Figure 2 View of the RS 485-IS Coupler

Features

Characteristics of the RS 485-IS Coupler:

- Transmission speed between 9.6 kbps and 1.5 Mbps
- Diagnostics by means of LED indicators
- Integrated bus termination for PROFIBUS RS 485-IS
- Up to 31 / 16 stations can be operated on any RS 485-IS Coupler (see Chapter 8.3 Technical data).
- Repeater function for the Ex area by means two RS 485-IS Couplers (same response as RS 485 Repeater)
- Certification to ATEX 100a
- Corresponding equipment for use in potentially explosive areas Zone 1, 2
- Intrinsic safety for PROFIBUS RS 485-IS subnet

Operation of the RS 485-IS Coupler as RS 485 Repeater

In order to be able to increase the lengths of your PROFIBUS RS 485-IS segments in the Ex area, you may operate two RS 485-IS Couplers in RS 485 repeater mode. Please note:

- You may operate a maximum of five segments in series.
- The segment cable length specified in the technical data in Chapter 8.3 must be adhered to.

3 Installation / Removal

Installation Position

The RS 485-IS Coupler can be mounted vertically or horizontally. The maximum ambient temperature in vertical mounting position is 40° C.

Open Equipment

The RS 485-IS Coupler is an of the open equipment class, i.e. it may only be installed in lockable or mechanically secured enclosures, cabinets or electrical switch rooms. Access to these enclosures, cabinets or electrical switch rooms is only permitted to instructed or authorized personnel.

Installation technique

The RS 485-IS Coupler is mounted on a DIN rail for S7 installation technology. Make allowances for trouble-free installation by maintaining a clearance of 40 mm at the bottom and the top of the module.

For further information relating to the S7 installation technique for modules, refer to the *S7-300 Automation System, Installation* Installation Manual.

Note

The RS 485-IS Coupler does not transfer signals on the S7 backplane bus.

Installation location

The RS 485-IS Coupler may be operated in potentially explosive atmospheres of Zone 2, provided it is mounted in suitable enclosures. The PROFIBUS RS 485-IS bus cable may be routed from the potentially explosive area to Zone 1.

Enclosures for Zone 2

The RS 485-IS Coupler must be installed in an enclosure with minimum IP 54. For operation of the enclosure and cable glands in Zone 2 a declaration of conformity to EN 50021 must be provided by the manufacturer.



Danger

Installation procedures may cause ignition by sparking or impermissible surface temperatures.

Never install the equipment under potentially explosive conditions !

Components Required

- Profile rail for S7 installation technology
- RS 485-IS Coupler

The order numbers are found in Chapter 9.

Installation

1. Mount the S7 profile rail onto a solid carrier.
2. Suspend the RS 485-IS Coupler onto the S7 profile rail, and then swivel it downwards.
3. Screw-tighten the RS 485-IS Coupler.

Removal

You remove the RS 485-IS Couplers in reverse sequence.

Before you remove an RS 485-IS Coupler that is in operation, switch off the 24 V DC power supply to the coupler.

4 Wiring

Note

Before you start wiring the system, please note the information in “General rules and regulations for wiring” in Chapter 6 of the *Distributed i/O device ET 200iS* Manual.

Chapter overview

Chapter	Topic	Page
4.1	Potential Isolation and Grounding	8
4.2	Operation on a grounded power supply	9
4.3	Operation with ungrounded reference potential	11
4.4	Terminals of the RS 485-IS Coupler	12
4.5	Connecting the power supply	13
4.6	Connecting PROFIBUS-DP	14
4.7	Connecting PROFIBUS RS 485-IS	15

4.1 Potential Isolation and Grounding

You may wire up a grounded or ungrounded 24 V power supply system, depending on the requirements of your assembly.

Characteristics of the RS 485-IS Coupler

- PROFIBUS-DP and the internal logic are galvanically interconnected
- PROFIBUS-DP and PROFIBUS RS 485-IS are galvanically isolated from the 24 V power supply
- PROFIBUS-DP is galvanically isolated from PROFIBUS RS 485-IS

4.2 Operation on a grounded power supply

Definition: Grounded–Neutral Supply

In a grounded power supply system, the neutral conductor of the mains is bonded to earth. A short of the live conductor to ground or to chassis ground of the system trips the protective devices.

Components and Protective Measures

Regulations prescribe various system components and compulsory protective measures for the installation of a plant. The type of components and compulsory protective measures depends on which DIN VDE regulation applies to your system installation.

- Master switch (see Figure 3, 

RS 485-IS Coupler on Grounded–Neutral Power Supply

Figure 3 shows the position of the RS 485-IS Coupler in a system connected to a TN-S power network. When the RS 485-IS Coupler is connected to grounded reference potential, all parasitic currents are discharged to ground via the grounding conductor.

Note

To operate the RS 485-IS in grounded mode, you need to bridge its M and functional ground terminals!

Note: The displayed setup of the power supply connections does not actually correspond with the live arrangement, but was selected for reasons of clarity.

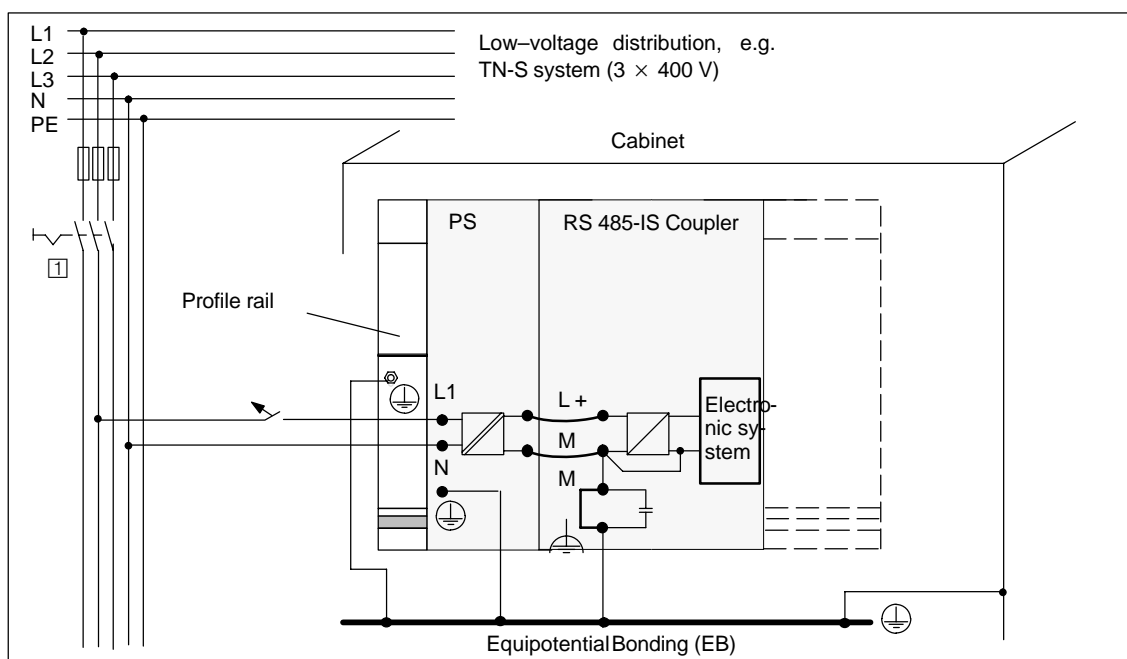

Figure 3 Operating the RS 485-IS Coupler on Grounded-Neutral Power Supply

4.3 Operation with ungrounded reference potential

Application

In large-scale systems you may have to install the RS 485-IS Coupler with ungrounded reference potential, for example, for monitoring short-circuit to ground. This applies in particular to systems operated in the chemical industry or in power plants, for example.

Discharging Parasitic Currents

In RS 485-IS Coupler installations with ungrounded reference potential, developing parasitic currents are discharged to protective ground via an integral capacitor (see Figure 4).

Wiring Diagram

Figure 4 shows an installation of the RS 485-IS Coupler with ungrounded reference potential. If you choose not to ground the reference potential of the 24 V power of your RS 485-IS Coupler, you need to **remove the jumper between the M terminals and system ground**. As long as this jumper is removed, the reference potential of the RS 485-IS Coupler is connected internally to the profile rail and the grounding conductor via a capacitor.

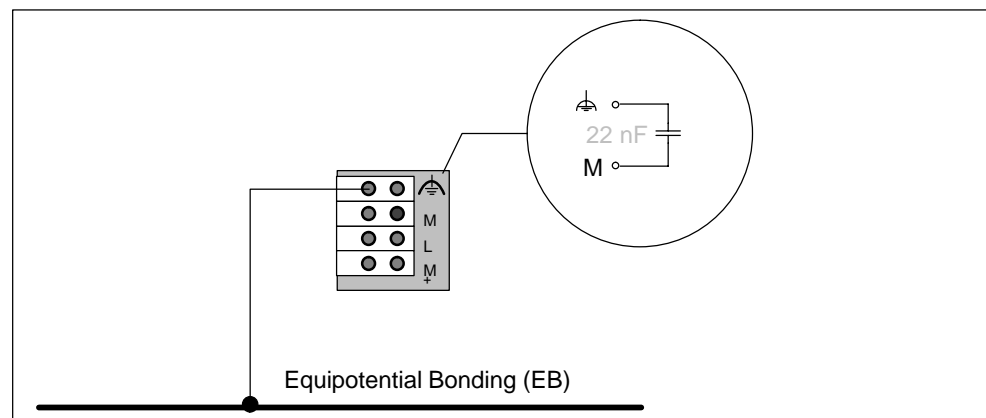

Figure 4 Installing the RS 485-IS Coupler with Ungrounded Reference Potential

4.4 Terminals of the RS 485-IS Coupler

Terminals for coupler mode

The figure below shows you the connections you need to wire up in order to operate the RS 485-IS Coupler:

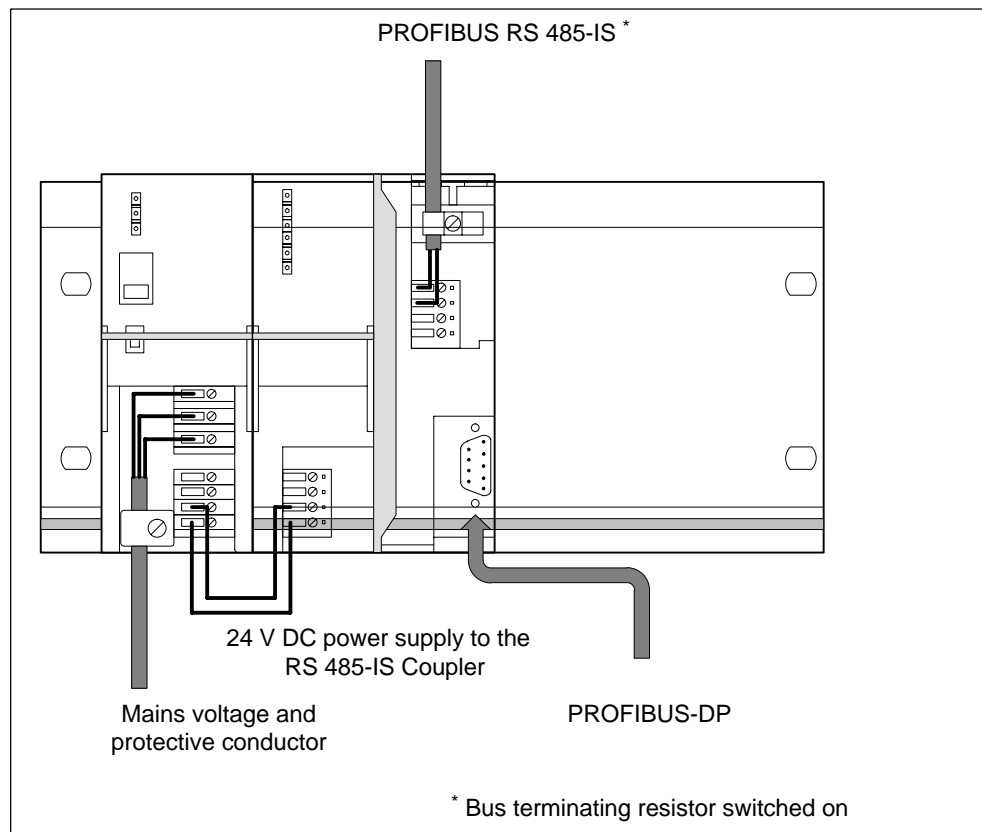

Figure 5 Terminals for coupler mode

Terminals for RS 485 Repeatermode

You need two RS 485-IS Couplers for operation in RS 485 Repeater mode. The figure below shows you the connections required for operation in RS 485-Repeater mode in Ex areas:

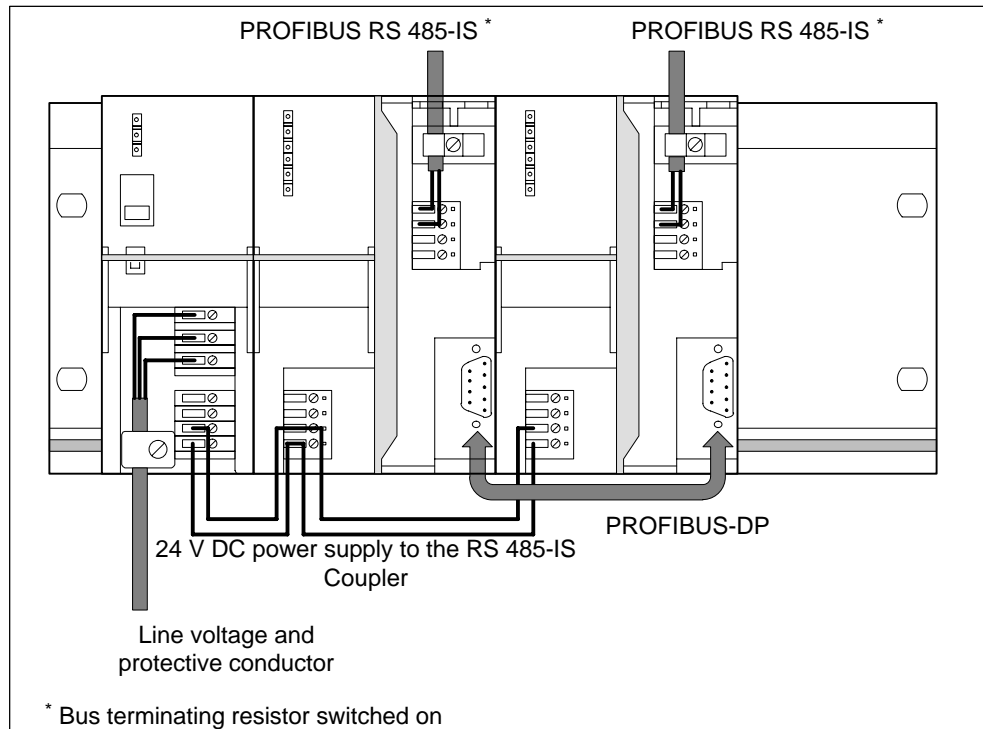

Figure 6 Terminals for RS 485 Repeatermode

4.5 Connecting the power supply

Tools required

You need a screwdriver with a 3 mm blade to terminate the power supply cables.

Power supply terminals

Pin assignment of the 4-pole screw terminals for the 24 V power supply:

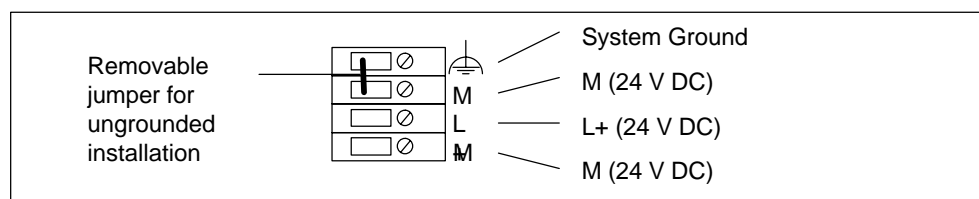

Figure 7 Power supply for the RS 485-IS Coupler

The maximum conductor cross-section is 2.5 mm². A strain relief is not provided.

4.6 Connecting PROFIBUS-DP

Tools required

You need a screwdriver with a 3 mm blade to terminate the power supply cables.

Bus cables and connectors

Always use the accessories specified in Chapter 4.7 for PROFIBUS-DP.

PROFIBUS-DP Connector

The 9-pin PROFIBUS-DP connector is located behind the bottom of the right-hand front-panel door of your RS 485-IS Coupler. Designation of the terminals:

Table 1 Pin-assignment of the PROFIBUS-DP connector

View	Pin	Signal	Description
	1	–	–
	2	–	–
	3	RxD / TxD–P	Data line B (suggested: red)
	4	RTS	Request To Send
	5	M5V	Data reference potential (from station)
	6	P5V	Power supply + (from station)
	7	–	–
	8	RxD / TxD–N	Data line A (suggested: green)
	9	–	–

Procedure

To connect your PROFIBUS-DP:

1. Insert the bus connector into the PROFIBUS socket.
2. Screw-tighten the bus connector.
3. When you install the RS 485-IS Coupler at the end of the PROFIBUS-DP segment, you need to switch on the terminating resistor on the bus connector.

4.7 Connecting PROFIBUS RS 485-IS

The following contents are mandatory for the installation of PROFIBUS RS 485-IS:

- PNO guideline "PROFIBUS RS 485-IS User and Installation Guide, Version 1.0, May 2003
PROFIBUS-Nutzerorganisation e. V.,
Haid-und-Neu-Straße 7, D-76131 Karlsruhe, Germany
Further information is found on the Internet:
<http://www.profibus.com>.
- Installation regulations to IEC 60079-14 (Installation of Electrical Systems in Potentially Explosive Atmospheres)



Warning

Always bond the RS 485-IS Coupler to equipotential ground before you connect the PROFIBUS RS 485-IS at its terminals!

Tools required

You need a screwdriver with a 3 mm blade to terminate the PROFIBUS RS 485-IS cables.

PROFIBUS RS 485-IS connector

The 4-pole screw terminals for the PROFIBUS RS 485-IS are located below the right-hand side of the front door of the RS 485-IS Coupler. Designation of the terminals:

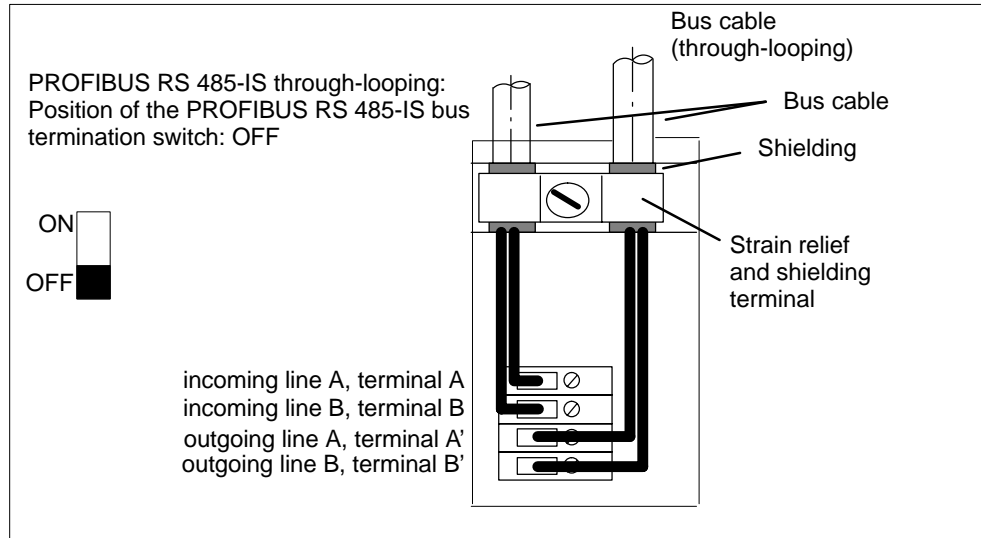

Figure 8 PROFIBUS RS 485-IS connection

Note

The signal is not amplified between the two screw terminals of the PROFIBUS RS 485-IS cable!

PROFIBUS RS 485-IS bus termination switch

The RS 485-IS Coupler is equipped with a PROFIBUS RS 485-IS bus termination switch:

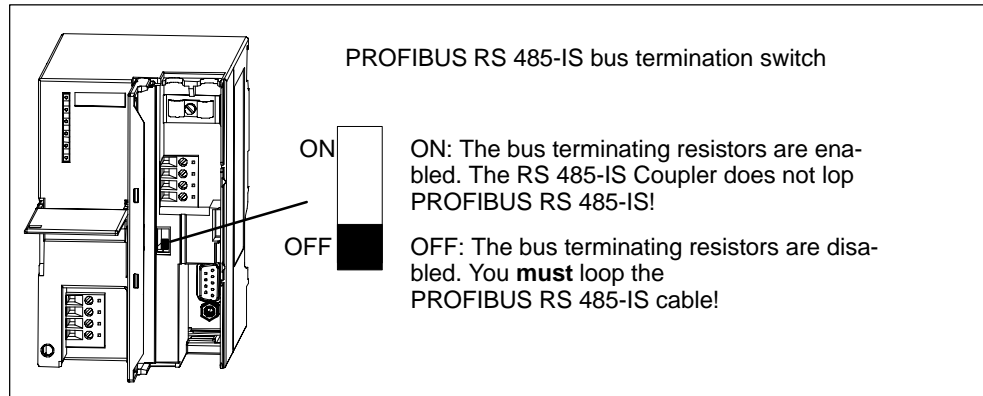

Figure 9 PROFIBUS RS 485-IS bus termination switch

Procedure

How to wire the PROFIBUS RS 485-IS cable:

1. Strip the bus cable as shown in Fig 10 and fold the shielding braid back over the insulation.

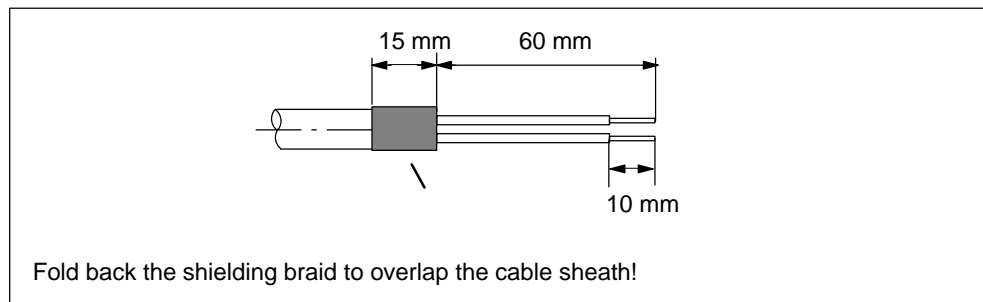

Figure 10 Stripping lengths

2. Place the shielding of the bus cable underneath the strain relief, and then screw-tighten this.
3. Terminate your bus cable at the screw terminals A and B. Make sure of the correct polarity (e.g. green wire to terminal A, red wire to terminal B).

5 Commissioning

Requirements

After you have completed the assembly and wiring of the RS 485-IS Coupler and after you have switched on the power supply, the device is ready for operation.

6 Diagnostics

Table 2 Status and error messages of the RS 485-IS Coupler

LEDs			Meaning	Remedy
DP1	DP2	ON		
*	*	on	Power to the RS 485-IS is switched on. The RS 485-IS Coupler is ready for operation.	–
off	off	off	Power to the RS 485-IS is not switched on, or the RS 485-IS Coupler is in error state.	Check the 24 V power supply to your RS 485-IS Coupler, or contact your Siemens partner.
flash es	*	on	PROFIBUS-DP message frames are received.	–
off	*	on	PROFIBUS-DP message frames are not received. Causes: <ul style="list-style-type: none"> • The DP Master is offline. • The bus cable is damaged. 	<ul style="list-style-type: none"> • Check the proper seating of the bus connector. • Check the bus cable connection to the DP master. • Switch the 24 V DC power module off and on again.
*	flash es	on	Receiving PROFIBUS RS 485-IS datagrams.	–
*	off	on	No datagrams from PROFIBUS RS 485-IS, e.g. <ul style="list-style-type: none"> • a station does not respond. The station may not be addressed. • The bus cable is damaged. 	<ul style="list-style-type: none"> • Check the stations which are connected to PROFIBUS RS 485-IS. • Check the bus cable connection to the DP master.

* Irrelevant

7 Maximum configuration

Introduction

In order to be able to use distributed i/O devices in Ex area Zone 1, the PROFIBUS DP must be installed intrinsically safe. You can separate the intrinsically safe PROFIBUS RS 485 IS from PROFIBUS DP with the help of the RS 485-IS Coupler.

Safety Data

At the RS 485-IS Coupler, you may only connect field devices which are certified for operation on a PROFIBUS RS 485-IS interface or ET 200iS with PROFIBUS DP Ex i interface:

- Up to 31 stations (Field Devices RS 485-IS) with PROFIBUS RS 485-IS interface,
- Up to 16 stations (ET 200iS stations) with PROFIBUS DP Ex i interface.

Mixed mode within the same segment is not permitted!

8 Technical Specifications

Chapter overview

Chapter	Topic	Page
8.1	General Technical Specifications	20
8.2	Standards, Certificates and Approvals	21
8.3	Technical Specifications	24

8.1 General Technical Specifications

General technical data of the RS 485-IS Coupler are found in Chapter 9 of the *Distributed I/O Device ET 200iS* Manual. Standards and approvals for the RS 485-IS Coupler are found in the following chapter 8.2.

Climatic Ambient Conditions

The following specification concerning the ambient climatic conditions for operation the of RS 485-IS Coupler overrides the general technical data in the *Distributed I/O Devices ET 200iS* Manual:

Table 3 Climatic Ambient Conditions

Ambient Conditions	Permissible Range
Temperature	
• Horizontal mounting position	– 25 to 60 °C
• Vertical mounting position	– 25 to 40 °C

8.2 Standards, Certificates and Approvals

The RS 485-IS Coupler is compliant with the following standards and approvals.

CE Certification



The RS 485-IS Coupler meets the requirements and safety objectives of the following EC directives, and it is compliant with the harmonized European standards (EN) which are published in the official documentation of the European Union:

- 89/336/EC "Electromagnetic Compatibility" (EMC Guideline)
- 73/23/EC "Electrical Equipment for Operation Within Specific Voltage Limits" (low-voltage guideline)

The EC Declarations of Conformity are available to the relevant authorities at:

Siemens Aktiengesellschaft
Automation and Drives
A&D AS RD ST PLC
PO-Box 1963
D-92209 Amberg

UL and CSA certification



Underwriters Laboratories Inc. to

- UL 508 (Industrial Control Equipment)
- CAN/CSA C22.2 No. 14-M91 (Process Control Equipment)
- UL 1604, Third Edition (Hazardous Location)
- UL 913, Sixth Edition (Hazardous Location)
- UL 2279, First Edition (Hazardous Location)
- CAN/CSA C22.2 No. 213-M1987
- CAN/CSA C22.2 No. 157-92
- E79-11 und E79-15

APPROVED for use in
Class I, Division 2, Group A, B, C, D T4;
Class I, Zone 2, Group IIC T4
AIS Class I, Division 1, Group A, B, C, D
[AExib] IIC, Class I, Zone 1, 2, Group IIC

FM certification (in preparation)



Factory Mutual Research (FM) to Approval Standard Class Numbers 3600 (1998), 3610 (1999), 3611 (1999), 3810 (1989), Class I, Division 2, Group A, B, C, D T4
Class I, Zone 2, Group IIC T4
AIS Class I, Division 1, Group A, B, C, D
[AExib] IIC, Class I, Zone 1, 2, Group IIC

ATEX certification



KEMA 03 ATEX 1183 X to EN 50014:1997, EN 50020:2002, EN 50021:1999 and EN 50284:1999

 II 3 (2) G EEx nA [ib] IIC T4

The EC Declarations of Conformity are available to the responsible authorities at:

Siemens Aktiengesellschaft
Automation and Drives
A&D AS RD ST PLC
PO-Box 1963
D-92209 Amberg

IEC 61131

The RS 485-IS Coupler meets the requirements and criteria of the Standard IEC 61131-2 (Programmable Logic Controllers, Part 2: Equipment Requirements and Testing).

PROFIBUS Standard

The RS 485-IS Coupler is based on the Standard *IEC 61784-1:2002 Ed1 CP 3/1*.

Shipbuilding certification (in preparation)

Classification Societies:

- ABS (American Bureau of Shipping)
- BV (Bureau Veritas)
- DNV (Det Norske Veritas)
- GL (Germanischer Lloyd)
- LRS (Lloyds Register of Shipping)
- Class NK (Nippon Kaiji Kyokai)

Industrial Use

SIMATIC products are designed for industrial applications.

Table 4 Industrial Use

Fields of application	Requirements on	
	Noise emission	Interference-proofing
Industry	EN 61000-6-4: 2001	EN 61000-6-2: 2001

Operation in Residential Areas

To operate the RS 485-IS Coupler in residential areas, the degree of radio interference must comply with limit class B to EN 55011.

Suitable measures for ensuring radio interference limit class B are:

- Installation of the RS 485-IS Coupler in grounded switch cabinets/cubicles
- Installation of noise filters in the supply lines



Warning

There is a risk of harm to persons and material damage.

In potentially explosive locations there is a risk of harm to persons and material damage, if you disconnect a connector while the RS 485-IS Coupler is in operation.

In potentially explosive locations, always switch off power before you disconnect any one of the RS 485 Coupler connectors.

8.3 Technical data RS 485-IS Coupler (6ES7 972-0AC80-0XA0)

Dimensions and Weight		Notes on safety		
Dimensions W × H × D (mm)	80 × 125 × 130	• $U_0 =$	$V_{DC} =$	4.2 V
Weight	approx. 500 g	• $I_0 =$	$I_{SC} =$	93 mA
Module-specific Data		• $P_0 =$	0.1 W	
Transmission rate on PROFIBUS-DP, PROFIBUS RS 485-IS	9.6; 19.2; 45.45; 93.75; 187.5; 500 kbps; 1.5 Mbps	• U_i	$V_{max.} =$	± 4.2 V
Bus protocol	PROFIBUS-DP	• L_i, C_i	≈ 0 (can be neglected)	
Voltages, Currents, Potentials		• $A_m =$	250 VAC	
Power supply voltage to the RS 485-IS Coupler	24 V DC (20.4 V to 28.8 V)	• $T_a =$	-25 to +60 °C	
• Polarity reversal protection	yes	RS 485-IS segment		
• Power failure buffering	min. 5 ms	permissible cable length for one segment	RS 485-IS	DP Ex i
Potential isolation of the 24 V power supply		• 9.6 to 187.5 kbps	1000 m	200 m
• to PROFIBUS-DP	yes	• 500 kbps	400 m	200 m
Tested with	DC 500 V	• 1.5 Mbps	200 m	200 m
• to PROFIBUS RS 485-IS	yes	Maximum number of stations on PROFIBUS DP	max. 31	max. 16
Tested with	AC 1500 V	PROFIBUS RS 485-IS bus termination switch	integral, switched	
Current consumption of the RS 485-IS Coupler (24 V DC)	max. 150 mA			
Power loss of the module	typically 3 W			
Status, Interrupts, Diagnostics				
Status display	No			
Interrupts	none			
Diagnostic Functions	yes			
• PROFIBUS-DP (primary) bus monitoring	yellow LED "DP1"			
• PROFIBUS RS 485-IS (secondary) bus monitoring	yellow LED "DP2"			
• 24 V power supply monitoring	green LED "ON"			

9 Order numbers

Table 5 RS 485-IS Coupler Order Number

Component	Order Number
RS 485-IS Coupler	6ES7 972-0AC80-0XA0
Profile rail for S7 installation technology <ul style="list-style-type: none">• 480 mm• 530 mm• 620 mm• 2000 mm	6ES7 390-1AE80-0AA0 6ES7 390-1AF30-0AA0 6ES7 390-1AJ30-0AA0 6ES7 390-1BC00-0AA0
PROFIBUS-DPbus connector <ul style="list-style-type: none">• for PROFIBUS-DP through-loop (without PG socket)	6ES7 972-0BA30-0XA0
PROFIBUS-DP bus cable <ul style="list-style-type: none">• standard (flexible)	6XV1 830-0EH10

10 Certifications

Chapter overview

Topic
EC-TYPE EXAMINATION CERTIFICATE
Declaration of EC-Conformity



translation

Original language: German

(1) **EC-TYPE EXAMINATION CERTIFICATE**

(2) Equipment or protective system intended for use in potentially explosive atmospheres - Directive 94/9/EC

(3) EC-Type Examination Certificate Number: **KEMA 03ATEX1183 X**

(4) Equipment or protective system: **Coupler RS 485-IS Model 6ES7 972 - 0AC80 - 0XA0**

(5) Manufacturer: **SIEMENS AG**

(6) Address: **Werner-von-Siemens-Strasse 50, 92224 Amberg, Germany**

(7) This equipment or protective system and any acceptable variation thereto is specified in the schedule to this certificate and the documents therein referred to.

(8) KEMA Quality B.V., notified body number 0344 in accordance with Article 9 of the Council Directive 94/9/EC of 23 March 1994, certifies that this equipment or protective system has been found to comply with the Essential Health and Safety Requirements relating to the design and construction of equipment and protective systems intended for use in potentially explosive atmospheres given in Annex II to the directive.

The examination and test results are recorded in confidential report no. 2026281.

(9) Compliance with the Essential Health and Safety Requirements has been assured by compliance with:

EN 50014 : 1997

EN 50020 : 2002

EN 50021 : 1999

(10) If the sign "X" is placed after the certificate number, it indicates that the equipment or protective system is subject to special conditions for safe use specified in the schedule to this certificate.

(11) This EC-Type Examination Certificate relates only to the design, examination and tests of the specified equipment or protective system according to the Directive 94/9/EC. Further requirements of the directive apply to the manufacturing process and supply of this equipment or protective system. These are not covered by this certificate.

(12) The marking of the equipment or protective system shall include the following:



II 3(2) G EEx nA [ib] IIC T4

Arnhem, 15 September 2003
KEMA Quality B.V.

C.G. van Es
Certification Manager

* This Certificate may only be reproduced in its entirety and without any change



SCHEDULE

(13)

(14)

to EC-Type Examination Certificate KEMA 03ATEX1183 X

(15) **Description**

The Coupler RS 485-IS Model 6ES7 972 – 0AC80 – 0XA0 is used for safe separation between intrinsically safe and non-intrinsically safe PROFIBUS-DP segments. The intrinsically safe circuits at terminal block X3 are suitable for connection to a fieldbus system.

Ambient temperature range -25 °C ... +60 °C.

Electrical data

Supply circuit.....	$U_n = 20,4...28,8 \text{ Vdc}$
Terminal block X1 (L+ und M)	$I_{max} = 120 \text{ mA}$
	$U_m = 250 \text{ Vac}$

Input/Output RS 485-IS	in type of protection intrinsic safety EEx ib IIC, with the following maximum values:
Terminal block X3 (A, B, A', B')	

$U_o = 4,2 \text{ V}$
$I_o = 93 \text{ mA (linear)}$
$P_o = 0,1 \text{ W}$

The cable connected to the Input/Output shall not exceed the values of $L/R = 30 \mu\text{H}/\text{Ohm}$ and $C = 500 \text{ nF/km}$.

The effective internal capacitance C_i and inductance L_i of the other equipment connected to this circuit shall be negligibly small.

And only for connection to a certified intrinsically safe circuit (for instance a fieldbus system), with the following maximum values:

$U_i = 4,2 \text{ V}$

I_i and P_i are determined by U_i . The effective internal capacitance C_i and inductance L_i are negligibly small.

All intrinsically safe circuits are infallibly galvanically isolated from all other circuits up to a peak voltage of 375 V.

Routine tests

The transformer T1400 shall be subjected to a routine test, as laid down in drawing No. 4NEA 999 3945 01.

(16) **Report**

KEMA No. 2026281.

SCHEDULE

- (13)
- (14) **to EC-Type Examination Certificate KEMA 03ATEX1183 X**

(17) **Special conditions for safe use**

The Coupler RS 485-IS Model 6ES7 972 – 0AC80 – 0XA0 shall be installed in a metal enclosed panel or rack providing a degree of ingress protection of at least IP54 according to EN 60529, taking into account the environmental conditions under which the equipment will be used.

When at any cable or cable entry point of this panel or rack the temperature under rated conditions is higher than 70 °C or the temperature under rated conditions at the branching point of the conductors is higher than 80 °C, the temperature specifications of the selected cables should be higher than the actual measured temperature values.

These conditions apply only for applications which require category 3 equipment.

(18) **Essential Health and Safety Requirements**

Covered by the standards listed at (9).

(19) **Test documentation**

	<u>dated</u>
1. Com_Types_Reassurance.doc	04.07.2003
2. Drawing No. A5E00187495B (8 sheets))	
A5E00187455A (9 sheets))	
A5E00187455 (5 sheets))	
A5E00187455B (4 sheets))	
A5E00149490B (2 sheets))	
A5E00187455A (9 sheets))	11.07.2003
A5E00219050A)	
A5E00187492A (7 sheets))	
A5E00187492 (3 sheets))	
A5E00187492B (3 sheets))	
A5E00219051A)	
4NEA 999 3945 01	19.08.2003

SIEMENS

Declaration of EC-Conformity

We

**Siemens AG,
A&D AS**

**Werner-von-Siemens-Straße 50,
92224 Amberg**

declare under our sole responsibility that the product:

Coupler RS 485-IS Model 6ES7 972-0AC80-0XA0

(name, type or model)

to which this declaration relates is in conformity with the following standards or normative documents:

**EN 50014: 1997, EN 50020: 2002, EN 50021: 1999,
EN 61000-6-2: 2001, EN 61000-6-4: 2001**

(title and / or number and date of issue of the standards or other normative documents)

The indicated product is in conformance with the regulation of the following European Directives:

94/9 EC As set out in Article 9 of the European Community guideline 94/9/EC of 23 March 1994, the fundamental safety and health requirements for the conception and construction of devices and protection systems for agreed use in hazardous areas are confirmed in accordance with Appendix II of the guideline.

Name of notified body - EC type evaluation certificate No.:



**KEMA 03 ATEX 1183 X
N.V. KEMA
Utrechtseweg 310
6812 AR Arnhem
Postfach 9035, 6800 ET Arnhem, Niederlande**

Identification No. of notified body "Production control"

0344

89/336/EEC Council Directive on the harmonization of the laws of the member states relating to electromagnetic compatibility (EMC Directive).

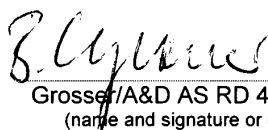
Amberg, 2003-09-15
(place and date of issue)

 
Grosse/A&D AS RD 4 Rapp/A&D AS EWA QSD
(name and signature or equivalent marking of authorized person)

