

SIEMENS

SIMATIC VPU200/565

Programming Manual

Order Number: PPX:560/65-8102
Manual Assembly Number: 2597773-0006
Third Edition

 **DANGER**

DANGER indicates an imminently hazardous situation that, if not avoided, will result in death or serious injury.

DANGER is limited to the most extreme situations.

 **WARNING**

WARNING indicates a potentially hazardous situation that, if not avoided, could result in death or serious injury, and/or property damage.

 **CAUTION**

CAUTION indicates a potentially hazardous situation that, if not avoided, could result in minor or moderate injury, and/or damage to property.

CAUTION is also used for property-damage-only accidents.

**Copyright 1995 by Siemens Energy & Automation, Inc.
All Rights Reserved — Printed in USA**

Reproduction, transmission, or use of this document or contents is not permitted without express consent of Siemens Energy & Automation, Inc. All rights, including rights created by patent grant or registration of a utility model or design, are reserved.

Since Siemens Energy & Automation, Inc., does not possess full access to data concerning all of the uses and applications of customer's products, we do not assume responsibility either for customer product design or for any infringements of patents or rights of others which may result from our assistance.

MANUAL PUBLICATION HISTORY

SIMATIC VPU200/565 Programming Manual

Order Manual Number: PPX:560/65-8102

Refer to this history in all correspondence and/or discussion about this manual.

Event	Date	Description
Original Issue	4/85	Original Edition (2493939-0001)
Second Edition	06/86	Second Edition (2493939-0002)
Third Edition	10/95	Third Edition (2493939-0003)

LIST OF EFFECTIVE PAGES

Pages	Description	Pages	Description
Cover/Copyright	Third		
History/Effective Pages	Third		
iii — vii	Third		
1-1 — 1-3	Third		
2-1 — 2-6	Third		
3-1 — 3-12	Third		
4-1 — 4-4	Third		
5-1 — 5-8	Third		
6-1 — 6-25	Third		
7-1 — 7-16	Third		
8-1 — 8-14	Third		
A-1 — A-2	Third		
Registration	Third		

Contents

Chapter 1 Manual Overview

1.1	Introduction	1-2
1.2	Manual Content	1-3

Chapter 2 Start-Up

2.1	Loading the Operating System (O.S.)	2-2
2.2	Selecting Operating Mode	2-4
	Message Fields	2-5
	Function Keys	2-5

Chapter 3 Programming Loops

3.1	Available Functions	3-2
	The Movement Function Keys	3-3
	The MODIFY Function Key	3-3
	The R/S Function Key	3-9
	The COPY Function Key	3-12
	The DEL Function Key	3-12

Chapter 4 Debug for 565 Operations

4.1	Additions to the Debug Operation	4-2
-----	--	-----

Chapter 5 Programming Analog Alarms

5.1	Introduction	5-2
5.2	Available Functions	5-3
	The Movement Function Keys	5-4
	The FIND Function Key	5-4
	The MODIFY Function Key	5-4
	The COPY Function Key	5-8
	The DEL Function Key	5-8

Chapter 6 Programming Special Functions

6.1	Introduction	6-2
6.2	Available Functions	6-3
	The Movement Function Keys	6-4
	The DISPLAY Function Key	6-4
	SFSUB Header	6-5
	SFPGM Header	6-5
	The COPY Function Key	6-9
	The DEL Function Key	6-10
6.3	The Special Function Language	6-11
	Special Function Commands	6-11
	The Special Function Variables	6-15
	The Special Function Operators	6-19
6.4	Additions to the Modify and Insert Operations	6-22
6.5	Additions to the Find Operation	6-25

Chapter 7 Using Support Functions

7.1	Introduction	7-2
7.2	Complete Support Functions	7-4
7.3	Accessing Support Functions	7-5
	Support Functions 10–13 – P/C Restarts	7-5
	Function 14 – Watchdog Timer	7-5
	Function 15 – Software Part Number	7-6
	Function 17 – Compare P/C to Disk	7-6
	Function 18 – P/C Time of Day	7-9
	Function 19 – Set P/C Scan Time	7-9
	Function 20 – Run P/C Diagnostics	7-10
	Function 21 – Run Remote Base Diagnostics	7-10
	Function 25 – Display Failed I/O	7-10
	Function 27 – P/C Card Failure Class	7-11
	Function 29 – Show P/C Diagnostic Cell	7-12
	Functions 31–37, 74–77 – Clear P/C Memory	7-12
	Functions 60–67 – Save P/C	7-13
	Functions 90–99 – Load P/C	7-13
	Function 81 – Select P/C Mode	7-14
	Function 82 – Hot Back Up	7-14
7.4	Accessing Auxiliary Support Functions	7-16

Chapter 8 Printing

8.1	Introduction	8-2
8.2	Configuring the Parameters for Printing	8-4

8.3	Operation of the Print Key	8-6
8.4	Operation of the Print Function Key	8-7
	Printing while in the Online Mode	8-7
	Memory Configuration	8-8
	I/O Configuration	8-8
	Ladders	8-8
	Printing while in the Offline Mode	8-8
	Synonyms	8-9
	Memory Configuration	8-9
	I/O Configuration	8-10
	Ladders	8-10
8.5	Interrupting the Print Operation	8-11
8.6	Printing Cross-References	8-13
Appendix A Error Messages		
A.1	Types of Error Checking	A-2

List of Figures

2-1	VPU200	2-2
2-2	Mode Selection Screen	2-3
2-3	Message Areas of the VPU200	2-5
2-4	565 Menu Hierarchy	2-6
3-1	Loop Directory	3-2
3-2	Loop Programming Table	3-4
4-1	Accessing the Debug Functions	4-2
5-1	Locating Analog Alarm Function	5-2
5-2	Analog Alarm Directory	5-3
6-1	Accessing SF Programming Operation	6-2
6-2	Special Function Program Directory	6-3
6-3	SF Program Example	6-4
6-4	MODIFY and INSERT Menu Hierarchy	6-23
6-5	FIND Menu Hierarchy	6-25
7-1	Accessing Support Functions Menu	7-2
7-2	Accessing Auxiliary Support Functions Menu	7-3
7-3	Support Functions Menu, page 1	7-4
7-4	Compare P/C to Disk Menu	7-6
7-5	Example Listing of P/C Card Failure Class	7-11
7-6	Result of Function 29	7-12
7-7	Support Functions Menu, page 2	7-13
7-8	Online Auxiliary Support Functions Menu	7-16
8-1	Print Hierarchy	8-3
8-2	Printing Parameters	8-4
8-3	Online Mode Print Options	8-7
8-4	Offline Mode Print Options	8-9
8-5	Accessing Print Cross-Reference	8-13
8-6	Cross-Reference Options Select	8-14

List of Tables

3-1	Loop Programming Entries	3-6
3-2	RAMP/SOAK Programming Table	3-9
3-3	RAMP/SOAK Entries	3-11
5-1	Analog Alarm Programming	5-5
5-2	Valid Responses for Analog Alarm	5-6
6-1	Special Function Language	6-12
6-2	Variable Types	6-16
6-3	Basic MATH Operations	6-19
6-4	Additional MATH Functions	6-20
6-5	IF Statement Operators	6-21
6-6	IMATH Operators	6-21
A-1	Error Messages for Loop and Analog Alarm Entries	A-2
A-2	Error Checks for SF Statements	A-2

Chapter 1
Manual Overview

1.1	Introduction	1-2
1.2	Manual Content	1-3

1.1 Introduction

This publication presents SIMATIC® VPU200™ operations available for programming the SIMATIC® 565 Programmable Controller (P/C). These operations are in addition to those available with the SIMATIC® 560™ P/C. Please reference the *SIMATIC VPU200/560 Programming Manual* (PPX:560/65–8102) for instructions on 560 programming, VPU200 basic operations, and error messages displayed by the VPU200.

Arrangement of the manual is as follows:

Chapter 2. Start-Up – Details loading operating system disk and selecting operating mode.

Chapter 3. Programming Loops – Describes accessing loop programming table and gives options for the various parameters.

Chapter 4. Debug for 565 Operations – Gives the additions to the debug operation for loops and analog alarms.

Chapter 5. Programming Analog Alarms – Gives directions for accessing the analog alarm directory and entering the alarm data.

Chapter 6. Programming Special Functions – Explains the types of special function programming and lists operators and parameters to use with each type of program.

Chapter 7. Using VPU200 Support Functions – Gives instructions for accessing both the complete support functions and auxiliary functions menus, and describes operation performed with each function.

Chapter 8. Printing – Describes print options available and gives instructions for configuring print parameters and selecting print options.

Chapter 2

Start-Up

2.1	Loading the Operating System (O.S.)	2-2
2.2	Selecting Operating Mode	2-4
	Message Fields	2-5
	Function Keys	2-5

2.1 Loading the Operating System (O.S.)

To load the O.S., power up the VPU200 by pressing the rocker switch (located on the front of the VPU) to the ON position (See Figure 2-1.) Next, press the spacebar to display the Power-up Menu. This menu contains the options for loading O.S., copying and formatting disks, and running diagnostics on the VPU. Before loading the O.S., run diagnostics and copy or format any disks as needed. Once the O.S. is loaded, this menu may be accessed for these functions by either power cycling the VPU or exiting to the first menu after loading the O.S. and using the F1 key.

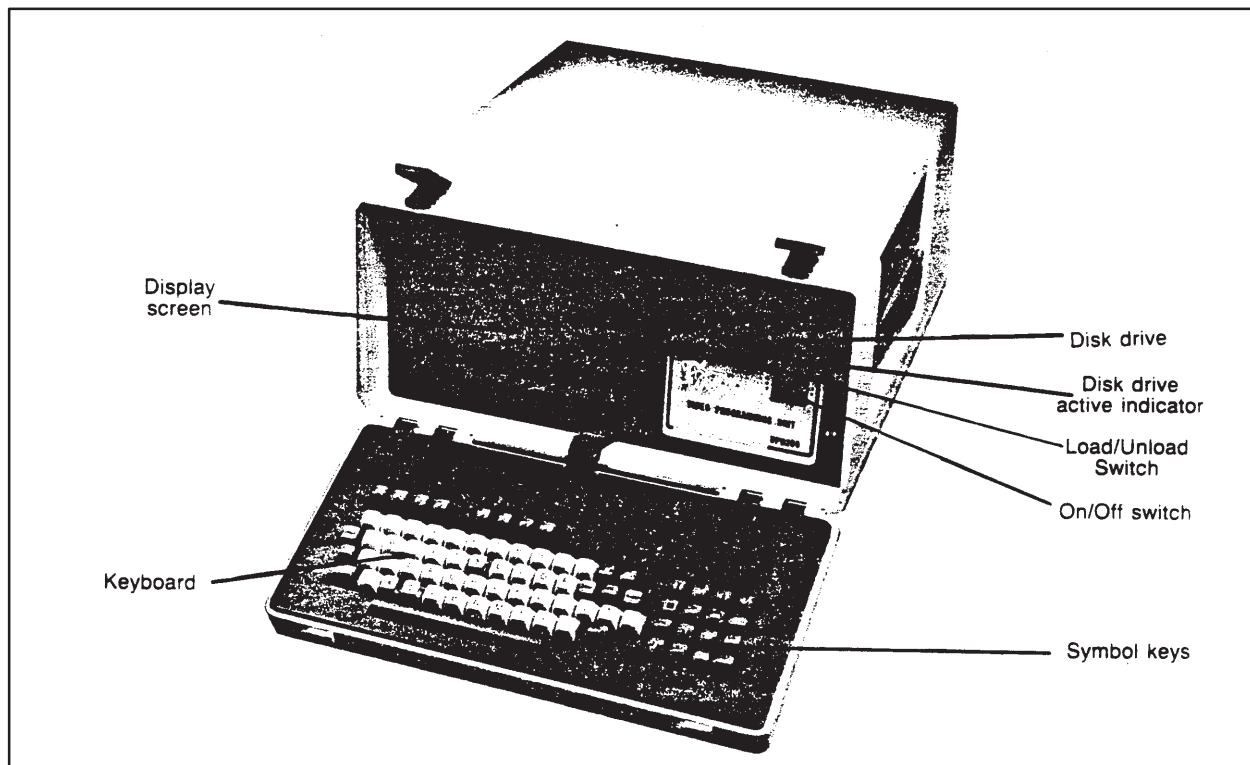

Figure 2-1 VPU200

Insert the O.S. disk into the disk drive and depress the load switch until it is flush with the front of the disk drive. Press F2 to initiate the load operation. Once the O.S. disk is loaded, the selection shown in Figure 2-2 appears at the bottom of the screen.



Figure 2-2 Mode Selection Screen

2.2 Selecting Operating Mode

The function keys available on the initial display are labeled as follows:

ABORT	ONLINE	OFFLINE	SUPPORT	XREF
F1	F2	F3	F4	F5

FUNCTION KEYS

The F1 key provides access to the Power-Up menu for copying and formatting disks or running VPU diagnostics.

The operating modes are ONLINE and OFFLINE. In online mode, the VPU and the programmable controller (P/C) communicate; and any changes entered on the VPU can be written directly to the P/C and to the disk in some instances. In Offline mode, there is no communication between the VPU and P/C; and programs edits, etc., must be written to disk to save.

Function keys F4 and F5 provide the options of accessing support functions or printing cross-references. If F4, Support, is selected, the VPU performs this operation in Online mode. (See Section 7.) With the selection of F5, printing of cross-references is done in the Offline mode. (See Section 8.)

After you make a selection from the menu, the operating system is loaded for that function. As the O.S. is loaded, a message and a series of dots appear on the screen. The message tells you what operating system is being loaded; i.e., OFFLINE, ONLINE, etc.

NOTE: After selecting either offline or online mode, configure S-memory. Until S-memory is allocated, the 565 functions are not accessible from the VPU200.

Message Fields

The screen of the VPU200, Figure 2-3, has areas reserved for display of specific types of messages:

- The Function Key numbers and labels which describe the operation available with the keys on that particular menu appear on the last line of the screen.
- System messages and prompts are given on the left side of the screen on the second and third lines from the bottom.
- Operating status is shown in three fields on the right side of the screen. In the first field, either REMOTE or LOCAL will be displayed to show the status of the Network Interface Module (NIM). If all NIM switches are set to LOCAL or no NIM is being used, LOCAL is displayed. If any NIM, is set to REMOTE mode, REMOTE is displayed. The second field shows the type of P/C that is used, and the third field gives the mode of the P/C— either PROGRAM or RUN.

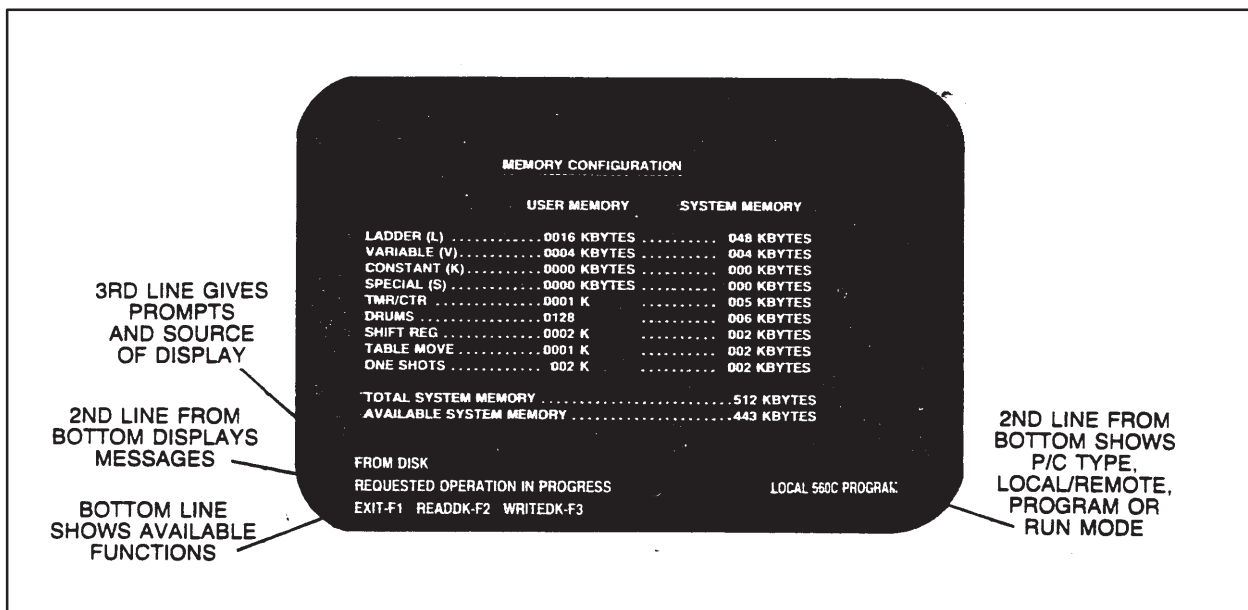

Figure 2-3 Message Areas of the VPU200

Function Keys

The function key line appears at the bottom of each display. The function identifiers, F1, F2, etc., show that the functions, EMT-F1, PRINT-F2, LADDER-F3, etc., are selected by pressing the corresponding numbers of the F keys on the VPU200 keyboard. If more than eight functions are available from a particular menu, the + (spacebar) is displayed to the right of the function key line. Press the spacebar to change the function key display to the additional functions. Press the spacebar again to return to the original display. The + (spacebar) does not appear if there is only one set of functions at a particular level.

Selecting Operating Mode (continued)

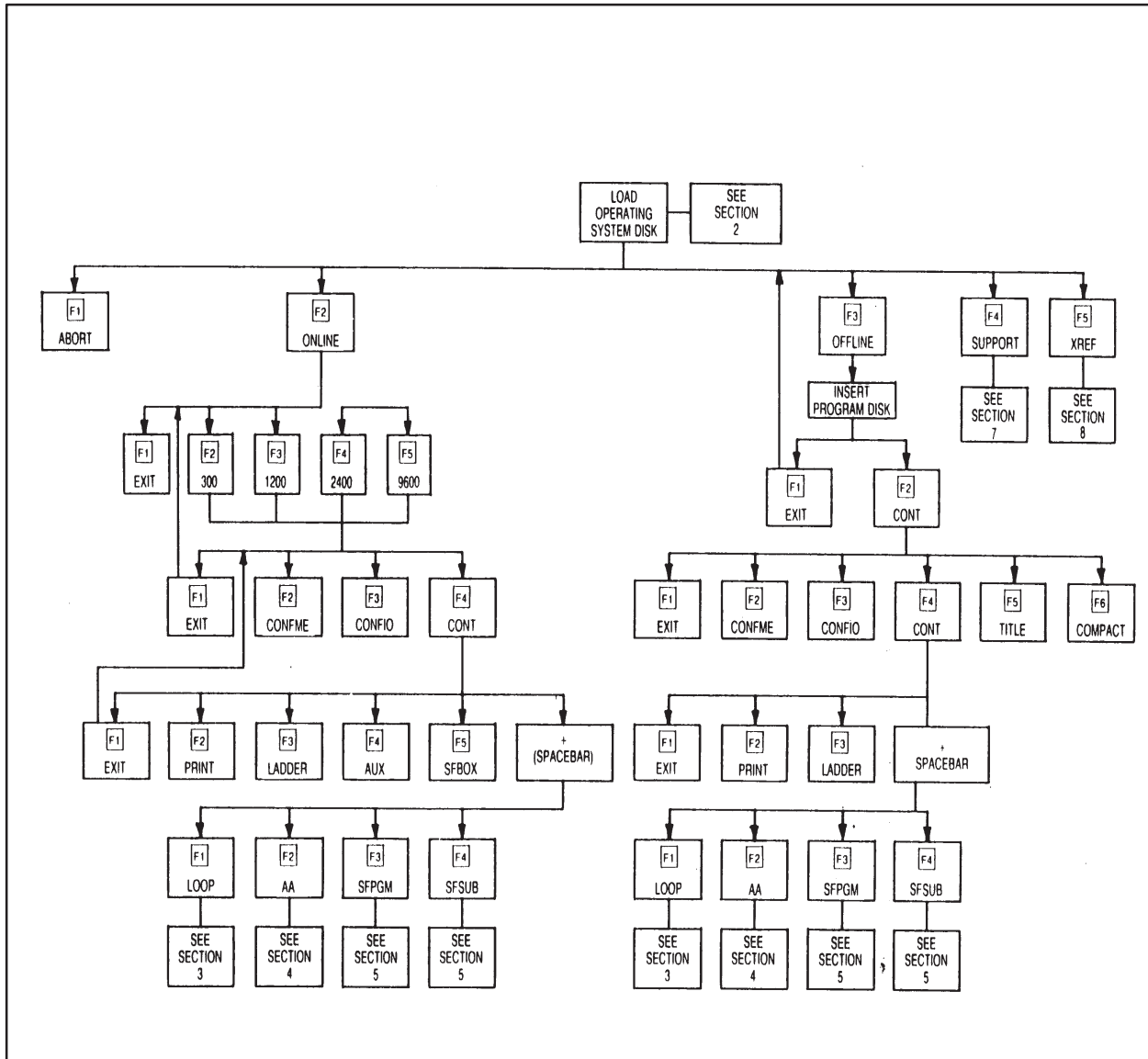

Figure 2-4 565 Menu Hierarchy

Figure 2-4 illustrates the menu hierarchy to access the 565 functions. Each function is discussed in the section referred to in the figure.

Chapter 3

Programming Loops

3.1	Available Functions	3-2
	The Movement Function Keys	3-3
	The MODIFY Function Key	3-3
	The R/S Function Key	3-9
	The COPY Function Key	3-12
	The DEL Function Key	3-12

3.1 Available Functions

When the LOOP (F1) function key is pressed, the first page of the loop directory will appear on the screen. This page contains the first 32 loops; there is a second page containing the remaining 32 loops.

The directory shows the title of each loop, whether the loop is programmed, and whether the Ramp/Soak feature has any programmed data. This information is derived from the data entered when the loops and R/S steps are programmed. Figure 3-1 shows an example of the first page of the loop directory.

PID LOOP DIRECTORY							
LOOP	PROG	RAMP/ SOAK	TITLE	LOOP	PROG	RAMP/ SOAK	TITLE
1	YES	YES	CONTROL 1	17	NO		
2	NO			18	YES	NO	AAAABBCC
3	NO			19	NO		
4	YES	NO	VALVE . A1	20	NO		
5	YES	YES	VALVE.A2	21	NO		
6	YES	NO	PRESSVAL	22	NO		
7	YES	NO	AUTOSTOP	23	YES	YES	BOILER. 1
8	YES	NO	ATOSTART	24	YES	YES	BOILER. 2
9	NO			25	YES	NO	BOILER.3
10	NO			26	NO		
11	NO			27	NO		
12	NO			28	NO		
13	NO			29	NO		
14	NO			30	NO		
15	NO			31	YES	YES	TEPMCNTL
16	NO			32	NO		

EXIT-F1 UP-F2 FOEN-F3 FIND-F4 MODIFY-F5 R/S-F6 COPY-F7 DEL-F8

Figure 3-1 Loop Directory

After pressing the Loop key, function keys are available as shown and described below.

EXIT	UP	DOWN	FIND	MODIFY	R/S	COPY	DEL
F1	F2	F3	F4	F5	F6	F7	F8

FUNCTION KEYS

The EXIT (F1) function key is used to leave the LOOP operation and return to the previous display.

The Movement Function Keys

There are three function keys used for moving through the pages of the directory. The UP (F2) function key will display the next page of the directory. The DOWN (F3) function key will display the previous page of the directory. The FIND (F4) function key is used to locate a specific loop in the directory. To do this:

Press the F4 function key. The following prompt then appears:

FIND LOOP: 01

The label for F1 is now ABORT, and may be used to halt the FIND operation and return to the previous menu.

To continue with the operation, type the Loop Number to be found and press the Return key. When the loop is found, the cursor is positioned on that Loop Number in the directory.

The MODIFY Function Key

The MODIFY (F5) function key is used to create or edit loops. To begin creating or editing a loop, use the arrow keys or the Find key to position the cursor on the loop number you wish to create or edit. Once the cursor is positioned on the correct number in the Loop Directory, press the MODIFY function key.

After the function key is pressed, the first page of the Loop Programming Table for the loop number selected is displayed. This table contains the entries which are necessary for defining a loop. An example of the Loop Programming Table is shown in Figure 3-2. The function key labels are shown and described following the figure.

Available Functions (continued)

Page 1

PID LOOP 30	TITLE: XXXXXXXX	LOCK SETPOINT	N
PID ALGORITHM:	V	LOCK AUTO/MANUAL	N
LOOP FLAG ADDRESS:	XXXXXX	LOCK CASCADE	N
PROCESS VARIABLE ADDRESS: ..	XXXXXX	PV IS BIPOLAR	N
SQUARE ROOT OF PV	N	20% OFFSET ON PV	N
PV RANGE:	HIGH = +1.00000		
	LOW = +0.00000		
SAMPLE RATE (SECS):	+2.00000		
DERIVATIVE GAIN LIMITING		PERFORM DERIVATIVE	
COEFFICIENT:	+10.0000	GAIN LIMITING	N
SPECIAL CALCULATION ON:	XX		
SFPGM NUMBER:	XXXX		
RAMP/SOAK FOR SP	N		
REMOTE SETPOINT	N	REMOTE SETPOINT ADDRESS: XXXXXX	
CLAMP SETPOINT LIMITS: HIGH =	+0.00000		
	LOW = +0.00000		
ERROR OPERATION:	X		
ABORT-F1 UP-F2 DOWN-F3 ENTER-F4			

Page 2

LOOP OUTPUT ADDRESS:	XXXXXX	OUTPUT IS BIPOLAR	N
REVERSE ACTING	N	20% OFFSET ON OUTPUT	N
LOOP GAIN	= +1.00000	(%/%)	
RESET (INTEGRAL TIME)	= +INF	(MIN)	
RATE (DERIVATIVE TIME)	= +0.00000	(MIN)	
FREEZE BIAS IF OUTPUT IS			
OUT OF RANGE	N		
ALARM DEADBAND	= +0.00000	(ENGR. UNITS)	
PV ALARMS:	LOW-LOW = +0.00000	(ENGR. UNITS)	
	LOW = +0.00000	(ENGR. UNITS)	
	HIGH = +0.00000	(ENGR. UNITS)	
	HIGH-HIGH = +0.00000	(ENGR. UNITS)	
MONITOR L-L/H-H ALARM	N	MONITOR L/H ALARM	N
RATE OF CHANGE ALARM:	= +0.00000	(ENGR. UNITS/MIN)	
MONITOR RATE OF			
CHANGE ALARM	N		
MONITOR BROKEN TRANSMITTER	N		
ABORT-F1 UP-F2 DOWN-F3 ENTER-F4			

Figure 3-2 Loop Programming Table

ABORT	UP	DOWN	ENTER
F1	F2	F3	F4

FUNCTION KEYS

The ABORT (F1) function key terminates the MODIFY operation, discards all changes which were made, and returns to the Loop Directory display. The ENTER (F4) function key saves all changes and returns the display to the Loop Directory. The VPU checks the validity of loop entries before saving. If an error is detected, the cursor is displayed at the first detected error. All entries must be complete and correct before the loop will be entered. See Appendix A for types of error messages.

The remaining function keys are used to move through the Loop Programming Table. When the first page of the table is shown, pressing the UP (F2) function key displays the second page of the table. When the second page is displayed, pressing the DOWN (F3) function key returns the display to the first page of the table. The arrow and Return keys allow you to move the cursor from entry to entry in the table. These keys operate in the following manner:

- The Return moves the cursor to the left field in the next line.
- The up and down arrow keys move the cursor to the previous or next line, respectively, in the same field areas.
- The right and left arrow keys move the cursor to the right or left fields on the same line. If no right field exists on a line, the cursor remains in the same position when the right arrow key is pressed.

As the cursor is moved from entry to entry, function keys are labeled as needed to input the loop data.

Table 3-1 given on the following pages lists each entry which appears in the Loop Programming Table and gives the responses which are permitted.

Available Functions (continued)

Table 3-1 Loop Programming Entries

PAGE	ENTRY NAME	AVAILABLE RESPONSES
1	Title	Up to eight alphanumeric characters, blanks, periods, and + or -.
1	PID Algorithm	POS-F5 or VEL-F6. If POS (Position) is chosen, a "P" will appear. For VEL (Velocity), a "V" will appear.
1	Loop Flag Address	WY-F5, V-F6, Y-F7, C-F8, or SPACEBAR, NONE-F1. This entry is not required. (Y and C entries designate 15 contiguous bits.)
1	Process Variable Address	WX-F5, WY-F6, or V-F7.
1	20% Offset on PV	YES-F5 or NO-F6.
1	Square Root of PV	YES-F5 or NO-F6.
1	PV Range (High and Low)	Any real numbers in the proper format. An error will result if the High value is lower than the Low value.
1	Sample Rate (Secs)	Any floating point number between 0.1 and 6553.5. The value should have only one digit after the decimal point. Any additional digits will be rounded to the nearest tenth.
1	Special Calculation On	PV-F5, SP-F6, or NONE-F7. This is optional and allows you to invoke a SFPGM for the Process Variable (PV) or the Setpoint (SP).
1	SFPGM Number	This is ignored if NONE was chosen for the last entry. Otherwise, enter the number of the SFPGM to be used.
1	Derivative Gain Limiting Coefficient	Any floating point number between 1 and Infinity.
1	Perform Derivative Gain Limiting	YES-F5 or NO-F6
1	Lock Setpoint	YES-F5 or NO-F6
1	Lock Auto/Manual	YES-F5 or NO-F6
1	Lock Cascade	YES-F5 or NO-F6
1	PV is Bipolar	YES-F5 or NO-F6

Table 3-1 Loop Programming Entries (continued)

PAGE	ENTRY NAME	AVAILABLE RESPONSES
1	Ramp/Soak for SP	YES-F5 or NO-F6. If the REMOTE SETPOINT is currently in effect and YES is chosen here, a prompt appears to ask whether you wish to cancel the REMOTE SETPOINT. Answering YES will cancel the REMOTE SETPOINT; answering NO will change this entry to NO.
1	Remote Setpoint	YES-F5 or NO-F6. If the RAMP/SOAK is currently in effect and YES is chosen here, a prompt appears to ask whether you wish to cancel the RAMP/SOAK. Answering YES will cancel the RAMP/SOAK; if NO is given, this entry will change to NO.
1	Remote Setpoint Address	No entry is needed if REMOTE SETPOINT is not selected. If it is, WX-F5, WY-F6, V-F7, and K-F8 will be available. After one of these types is chosen, identify it with a location number (WX256, V1000, etc.).
1	Clamp Setpoint Limits (High and Low)	This feature is optional; if you wish to use it, enter a real number for both lines. An error will result if the High value is lower than the Low value. If you do not wish to use this feature, be sure to press the NONE function key. If NONE is selected, High and Low limit fields will be clamped to zero.
1	Error Operation	SQURED-F5, DEDBND-F6, or NONE-F7.
2	Loop Output Address	WY-F5 or V-F6. After choosing the variable type, identify it with a number.
2	20% Offset on Output	YES-F5 or NO-F6.
2	Reverse Acting	YES-F5 or NO-F6.
2	Output is Bipolar	YES-F5 or NO-F6
2	Loop Gain (%/%)	Any floating point number between 0.01 and 100.00. If the value is less than 0.01, the entry will default to 0.01; if the value is greater than 100.00, the entry will default to 100.00.

Available Functions (continued)

Table 3-1 Loop Programming Entries (continued)

PAGE	ENTRY NAME	AVAILABLE RESPONSES
2	Reset (Integral Time) -Minutes-	Any floating point number between 0.01 and 999.99. Any values less than 0.01 will default to 0.01, and values greater than 999.99 will default to infinity.
2	Rate (Derivative Time) -Minutes-	Any floating point number between 0.01 and 999.99. Any values less than 0.01 will default to zero; any values greater than 999.99 will default to 999.99.
2	Freeze Bias if Output Is Out of Range	YES-F5 or NO-F6.
2	Alarm Deadband (Engr.Units)	Real numbers where $0 < N \leq$ (PVHI-PVLO).
2	PV Alarms (Engineering Units)	A floating point number. Note that $LOW-LOW \leq LOW < = HIGH < =$ HIGH-HIGH, and all values must be within the PV span, or an error will result.
2	Monitor L-L/H-H Alarm	YES-F5 or NO-F6
2	Monitor L/H Alarm	YES-F5 or NO-F6
2	Deviation Alarms (Engineering Units)	Any floating point number within the PV span. Note that $YELLOW < = ORANGE$ or an error will result.
2	Rate of Change Alarm (Engineering Units/mn)	Any floating point number.
2	Monitor Broken Transmitter	YES-F5 or NO-F6.
2	Monitor Deviation Alarms	YES-F5 or NO-F6
2	Monitor Rate of Change Alarm	YES-F5 or NO-F6

The R/S Function Key

The R/S (Ramp/Soak) function key is used to create or modify a Ramp/Soak table for a particular loop. To begin the operation, first place the cursor on the entry in the Loop Directory for which a Ramp/Soak table will be built or modified. You should also be sure that the Ramp/Soak entry in the Loop Programming Table is answered Yes.

Once the cursor is positioned, press the R/S (F6) function key. The Ramp/Soak Programming Table is then displayed. If No was given for the Ramp/Soak entry in the Loop Programming Table, the following message appears:

THE RAMP/SOAK IS NOT SELECTED IN THE LOOP TABLE

Table 3-2 shows an example of a RAMP/SOAK Programming Table. The function keys are then labeled as shown and described following the table.

Table 3-2 RAMP/SOAK Programming Table

PID LOOP 30						
RAMP/SOAK FLAG ADDRESS: XXXXXX						
STEP	R/S	STATUS BIT	SETPOINT (UNITS)	RAMP RATE (UNITS/MIN)	SOAK TIME (MIN)	DEADBAND (UNITS)
1	S	XXXXXX			XXXXXXXXXXXXX	XXXXXXXXXX
2	R	XXXXXX	XXXXXXXXXXXXX	XXXXXXXXXXXXX		
3	S	XXXXXX			XXXXXXXXXXXXX	XXXXXXXXXX
4	R	XXXXXX	XXXXXXXXXXXXX	XXXXXXXXXXXXX		
EXIT-F1 UP-F2 DOWN-F3 EDIT-F4						

Available Functions (continued)

EXIT	UP	DOWN	EDIT	INSLN	DELLN
F1	F2	F3	F4	F5	F6

•

FUNCTION KEYS

- F1** EXIT This function key is used to keep all changes, terminate the R/S operation, and return to the screen showing the Loop Directory.
- F2** UP This key displays the next page of the Ramp/Soak table.
- F3** DOWN This function key displays the previous page of the Ramp/Soak table.
- F4** EDIT The F4 key is used to place the VPU200 in the mode for altering a particular step in the Ramp/Soak Table.
- F5** INSLN (INSert LiNe.) This function key inserts a line before the step on which the cursor is placed.
- F6** DELLN (DELEte LiNe.) This function key removes the step on which the cursor is placed.

In addition to the function keys, the up arrow, down arrow and Return keys are operable. Use these keys to move the cursor up and down in the "STEP" column for selecting a step to be created or edited. The maximum number of steps that can be programmed for a loop is 256. Each display page of the R/S Table holds a maximum of 16 steps.

If you wish to alter an existing step, use the EDIT (F4) function key; if you wish to create a new step, use the INSLN (F5) function key. (To add steps after the last step in the table, press the Return key.)

Once one of the function keys or the Return key is pressed, you may use the right and left arrow keys to move from column to column in the step. As the cursor is moved from column to column, the available function keys change to reflect the responses which are allowed for the column in which the cursor is placed. Once the step is written, press the ENTER (F2) function key to enter the step and leave the EDIT mode. (If you wish to delete all the changes made to the step, press the ABORT (F1) function key. This also ends the EDIT mode and returns to the previous menu.)

Table 3-3 lists the column headings and the valid responses under each heading.

Table 3-3 RAMP/SOAK ENTRIES

COLUMN NAME	AVAILABLE RESPONSES
Ramp/Soak Flag Address	WY-F3, Y-F4, C-F5, V-F6 or NONE-F7. This is optional: if you do not wish to include it, press the NONE function key. If Y or C is chosen, the location number must be four less than the configured value since the ramp/soak flag occupies five bits.
R/S	RAMP-F3 or SOAK-F4. If you choose RAMP, an 'R' will appear; if you choose SOAK, an 'S' will appear. Note that if you change an 'R' to an 'S' (or vice versa), the columns which do not apply will be cleared.
Status Bit	C-F3, Y-F4, or NONE-F5. This is also optional: if you do not wish to include it, press the NONE (F5) function key.
Setpoint (Engineering Units)	This is only available if RAMP was chosen in the second column. The value entered must be in the range between PVLO and PVHI.
Ramp Rate (Engineering Units/Min)	This will only be available if Ramp is selected in column 2. The entry should be a floating point number (greater than 0) in the correct format.
Soak Time (Minutes)	This column will be blank unless Soak is chosen in column 2. The entry may be any real number between 0.1 and 1092.3. If a value less than 0.1 is given, the default will be 0.1; if a value greater than 1092.3 is given, the default is INF (infinity—To prevent this, insure that the value is not greater than 1092.3).
Deadband (Engr. Units)	Must be a real number where $0 < N \leq (PVHI-PVLO)$

Available Functions (continued)

The COPY Function Key

The COPY function key is used to copy information from one loop to another. (Also, if a Ramp/Soak table is constructed for the loop, it will be copied as well.) To begin the COPY operation, first place the cursor on the loop which will be copied. Once the cursor is positioned, press the COPY (F4) function key.

After the function key is pressed, the following prompt will appear on the screen:

COPY FROM LOOP AND R/S {loop number} TO: 01

The cursor will be on the number of the destination loop, which appears at the right of the prompt. You should next type the number of the destination loop over the number given on the screen. If you do not wish to continue with the COPY operation, use the ABORT (F1) function key. This will allow you to terminate the operation and return to the original menu from which the COPY operation was begun.

Once the destination address is typed, press the Return key to begin the operation. The loop will be copied to the specified loop number unless a loop already exists at that number. In this case, the following prompt will appear:

LOOP DATA {loop destination number} ALREADY EXISTS

The available function keys will change to an ABORT for the F1 function key and a REPLACE for the F2 function key. The ABORT function key allows you to enter another destination loop number. The REPLACE function key will cause the COPY operation to continue, which results in the information in the destination loop being overwritten by the new information. After the information is copied, the previous menu is displayed.

The DEL Function Key

The DEL (DELeTe) function key removes the information for a loop and its Ramp/Soak table. To begin the DEL operation, first place the cursor on the loop number to be deleted. Once the cursor is positioned, press the DEL (F8) function key. This will cause the following prompt to appear on the screen:

DELETE LOOP {number}: ARE YOU SURE

The functions shown at the bottom of the screen will change to a NO for the F1 function key and a YES for the F2 function key. If the NO function key is pressed, the DEL operation halts and the previous menu appears. If the YES function key is pressed, the DEL operation proceeds and the information is deleted. Upon completion of the delete function, the original menu appears on the screen.

Chapter 4

Debug for 565 Operations

4.1	Additions to the Debug Operation	4-2
-----	--	-----

4.1 Additions to the Debug Operation

Function keys are added to the DEBUG operation for troubleshooting and editing loop and analog alarm parameters. To access these functions, the VPU must be in the Online mode. Once Online mode is selected, proceed through the Ladder hierarchy to the DEBUG function key. Press the DEBUG function key. Next, press the spacebar. See Figure 4-1 for menu hierarchy to access these functions.

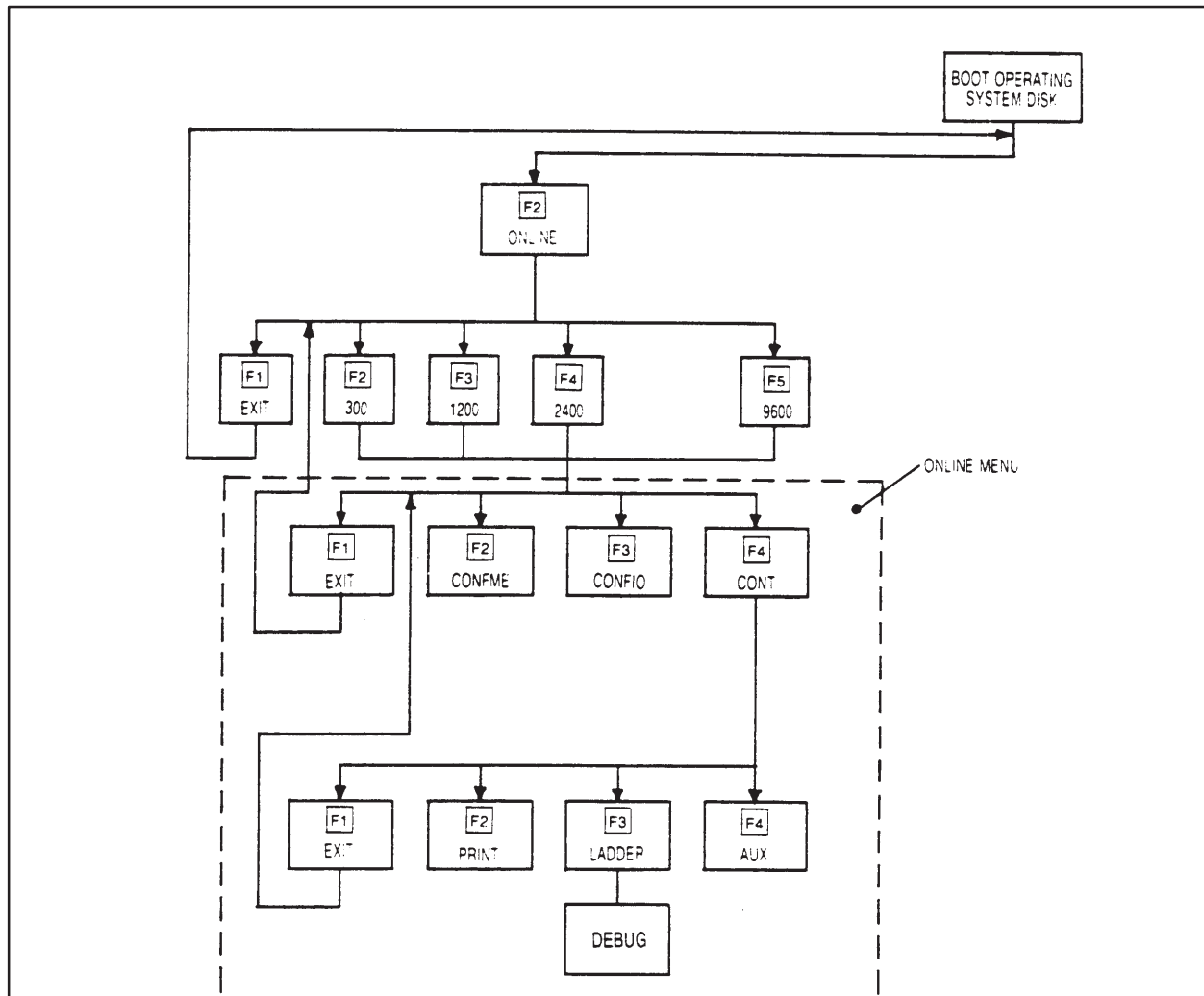

Figure 4-1 Accessing the Debug Functions

If the rungs of ladder logic are shown on the screen, then the following function keys appear when the spacebar is pressed:

FORCE	UP	DOWN	UNFORC	CTRTRMR	BLDCHT	WORDS	LOOP	+
F1	F2	F3	F4	F5	F6	F7	F8	(SPACE BAR)

FUNCTION KEYS

If the chart is shown instead of the rungs of ladder logic, the UP (F2), DOWN (F3), and WORDS (F7) function keys will not be available.

The Loop function key (F8) is used to view and change the parameters of loops. When the LOOP function key is pressed, the function keys will change to those for loop parameters. These function keys are shown below:

ABORT	LKC	LTD	LTI	LMX ...	LTS	LSP	READ
F1	F2	F3	F4	F5	F6	F7	F8

FUNCTION KEYS

The ABORT (F1) function key returns to the previous display. The READ (F8) function key obtains the value for the word which appears on the prompt line. The remaining function keys are the parameters for loops:

- The LKC (F2) function key is for loop gain;
- The LTD (F3) function key is for loop rate (derivative);
- The LTI (F4) function key is for loop reset (integral);
- The LMX (F5) function key is for loop bias;
- The LTS (F6) function key is for loop sample rate; and
- The LSP (F7) function key is for loop setpoint

After any of these are chosen, the prompt line will change to reflect the parameter chosen. Key in the loop number for the parameter you wish to view or change. The number cannot be greater than 64.

Additions to the Debug Operation (continued)

To change the value of a word, move the cursor to the right side of the equals sign. Number keys only are functional for entering values. Real numbers must be used in these fields.

Two additional functions are available in the DEBUG operation for creating loop and analog alarm value tables. These are accessed by pressing the BLDCHT (F6) function key. When this key is pressed, the following function keys are available:

EXIT	BITIO	CPWDS	WORD	CLRCHT	CLRLOC	LOOPWD	APV
F1	F2	F3	F4	F5	F6	F7	F8

FUNCTION KEYS

The new function keys are the LOOPWD (F7) and APV (F8) function keys. The LOOPWD function key allows you to place loop parameters into the chart. The parameters which may be placed in the chart are the following: LMN (loop output), LPV (process variable), LERR (loop error), LKC (loop gain), LTD (loop rate), LTI (loop reset), and LMX (loop bias). These parameters will appear at the bottom of the screen when the LOOPWD function key is pressed. After the parameter is chosen, it will appear in the chart.

The APV (F8) function key is for placement of process variable for analog alarms into the chart. After the function key is pressed, select the desired analog alarm number. After that, continue building or changing the chart as desired. When the chart is complete, press the EXIT function key.

Chapter 5

Programming Analog Alarms

- 5.1 **Introduction** 5-2
- 5.2 **Available Functions** 5-3
 - The Movement Function Keys 5-4
 - The FIND Function Key 5-4
 - The MODIFY Function Key 5-4
 - The COPY Function Key 5-8
 - The DEL Function Key 5-8

5.1 Introduction

Analog Alarms are accessed through the AN-ALARM (F2) function key which appears in the menu hierarchy as shown in Figure 5-1. Up to 128 Analog Alarms may be programmed.

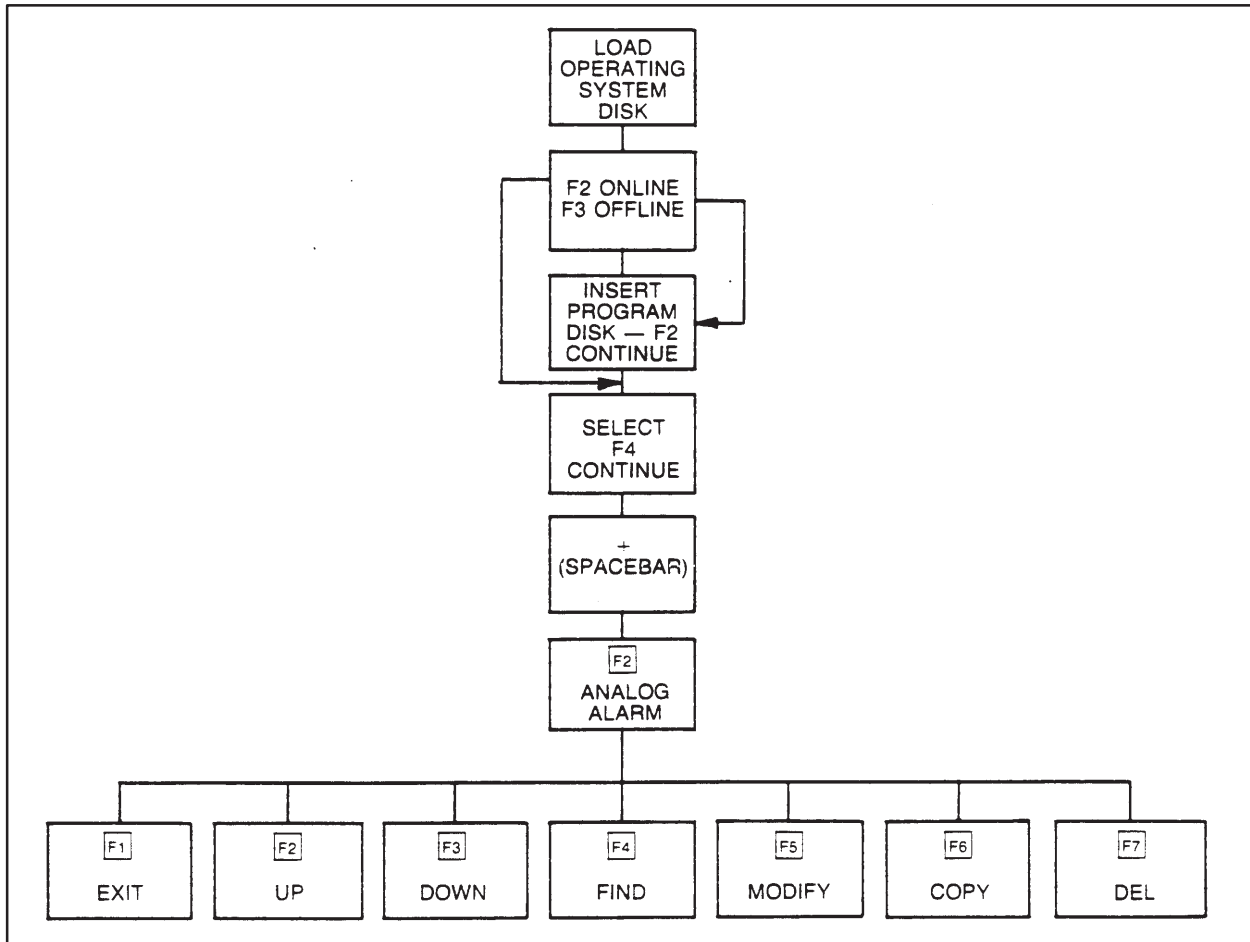

Figure 5-1 Locating Analog Alarm Function

5.2 Available Functions

When the AN-ALARM function key is pressed, the first page of the Analog Alarm Directory is displayed. Thirty-two alarms are displayed on each page of the directory as illustrated in Figure 5-2.

ANALOG ALARM DIRECTORY					
ALARM	PROG	TITLE	ALARM	PROG	TITLE
1	YES	ABCDEFGH	17	NO	
2	YES	MTR CTRL	18	YES	A B C D8
3	YES	PUMP 21A	19	NO	
4	YES	VLV P12	20	NO	
5	YES	EX 2	21	NO	
6	YES	ASDFGHJK	22	NO	
7	NO		23	NO	
8	NO		24	YES	ABC SAMP
9	YES	COMPUTE1	25	NO	
10	YES	FAN RM23	26	NO	
11	YES	PRINT V1	27	NO	
12	YES	CALC. SP	28	NO	
13	YES		29	NO	
14	YES	BURN X32	30	NO	
15	NO		31	NO	
16	NO		32	NO	

ABORT-F1 UP-F2 DOWN-F3 FIND-F4 MODIFY-F5 COPY-F6 DEL-F7

Figure 5-2 Analog Alarm Directory

The following function keys are available with the Analog Alarm Directory.

EXIT	UP	DOWN	FIND	MODIFY	COPY	DEL
F1	F2	F3	F4	F5	F6	F7

FUNCTION KEYS

The EXIT (F1) function key leaves the directory and returns to the previous display.

Available Functions (continued)

The Movement Function Keys

There are three function keys used for moving through the pages of the directory. The UP (F2) function key will display the next page of the directory. The DOWN (F3) function key will display the previous page of the directory.

The FIND Function Key

The FIND (F4) function key is used to locate a specific alarm in the directory. Pressing the F4 function key brings the following prompt to the screen: FIND ALARM: 001

The functions appearing at the bottom of the screen change so that ABORT is displayed for the F1 function key. This function key may be used to halt the FIND operation and return to the previous display.

To continue with the operation, type the desired alarm number and press the Return key. When the number is found, the cursor is positioned on that entry in the directory.

The MODIFY Function Key

The MODIFY (F5) function key is used to create or edit analog alarms. To begin the operation, move the cursor to the alarm number in the directory which will be created or modified. Once the cursor is positioned, press the MODIFY function key. This displays the Analog Alarm Programming Table. Table 5-1 shows an example.

Table 5-1 Analog Alarm Programming Table

ANALOG ALARM 128	TITLE: XXXXXXXX	
SAMPLE RATE (SECS)	+2.00000	ALARM FLAG ADDRESS: .XXXX
PROCESS VARIABLE ADDRESS:	XXXXXX	PV IS BIPOLARN
SQUARE ROOT OF PV	N	20% OFFSET ON PVN
PV RANGE:	HIGH= +1.00000	
	LOW= +0.00000	
SPECIAL FUNCTION	N	SFPGM NUMBER:XXXX
SP VALUE OR REMOTE SP:	SP VALUE	VALUE OR ADDRESS: +0.00000
CLAMP SETPOINT LIMITS:	HIGH= +0.00000	
	LOW= +0.00000	
ALARM DEADBAND	= +0.00000	(ENGR. UNITS)
PV ALARMS:	LOW-LOW= +0.00000	(ENGR. UNITS)
	LOW= +0.00000	(ENGR. UNITS)
	HIGH= +0.00000	(ENGR. UNITS)
	HIGH-HIGH= +0.00000	(ENGR. UNITS)
MONITOR L-L/H-H ALARM	N	MONITOR L/H ALARMN
DEVIATION ALARMS	YELLOW= +0.00000	(ENGR. UNITS)
	ORANGE= +0.00000	(ENGR. UNITS)
MONITOR DEVIATION ALARMS	N	
RATE OF CHANGE ALARM:	= +0.0000	(ENGR. UNITS/MIN)
MONITOR RATE OF CHANGE		MONITOR BROKEN
ALARM	N	TRANSMITTERN
ABORT-F1 ENTER-F2		

The available functions keys are labeled ABORT for the F1 function key and ENTER for the F2 function key. The ABORT function key halts the MODIFY operation, discards all changes, and returns to the analog alarm directory. The ENTER function key saves all changes and returns to the analog alarm directory. Along with the function keys, the arrow and Return keys are functional to allow moving from entry to entry in the table. When the cursor is positioned on an entry, the function keys are added to allow the appropriate responses.

Table 5-2 gives the valid responses for each entry in the Analog Alarm Programming Table.

Available Functions (continued)

Table 5-2 Valid Responses for Analog Alarm Table

ENTRY NAME	AVAILABLE RESPONSES
Title	Up to eight alphanumeric characters including blanks, periods, and plus/minus signs.
Sample Rate (Seconds)	Any floating point number between 0.5 and 32767.5. The digit after the decimal point must be a 0 or a 5—that is, all values are rounded to the nearest half-second. Also, any values less than 0.5 are set to 0.5 by default, and all values greater than 32767.5 are set to 32767.5 by default.
Alarm Flag Address	WY-F3, V-F4, Y-F5, C-F6, or NONE-F7. This is optional: press the NONE function key if you do not wish to use it. Otherwise, pick a variable category and identify it with a location number. (X and C require 11 contiguous bits for control and status flags.)
Process Variable Address	WX-F3, WY-F4, or V-F5. After the variable category is chosen, identify it with a unique number.
20% Offset on PV	YES-F3 or NO-F4.
Square Root of PV	YES-F3 or NO-F4.
PV Range (High and Low)	Any real number in the proper format. An error will result if the High value is lower than the Low value.
Special Function	YES-F3 or NO-F4. This entry is used to invoke a special function program. If 'NO' is chosen, the next entry is ignored.
SFPGM Number	This is only filled in if 'YES' was given in the last entry. The response given here should be the number of the SFPGM which is being used.
SP Value or Remote SP	VALUE-F3, REMOTE-F4, or NONE-F5. If 'NONE' is picked, the next entry is skipped.
Value or Address	This entry is only filled in if 'VALUE' or 'REMOTE' was given in the last entry. If "SP VALUE" appears for the last entry, then a floating point number is typed here. If "REMOTE SP" appears for the last entry, select either WX, WY, V, K or LMN. After the variable type is picked, it must be identified with a location number.

Table 5-2 Valid Responses for Analog Alarm Table (continued)

ENTRY NAME	AVAILABLE RESPONSES
Clamp Setpoint Limits (High and Low)	This feature is optional; if you use it, enter a real number for both limits. An error will result if the High value is lower than the Low value. If you do not wish to use this feature, be sure to press F3, NONE. If NONE is selected, High and Low limit fields will be clamped to zero.
Alarm Deadband (Engineering Units)	Must be a real number where $0 < N \leq PVHI - PVLO$
PV Alarms (Engineering Units)	Any floating point number within the PV span. An error will result unless $LOW - LOW \leq LOW \leq HIGH \leq HIGH - HIGH$.
Deviation Alarms (Engineering Units)	Any floating point number within the PV span. Note that $YELLOW \leq ORANGE$ or an error will result.
Rate of Change Alarm (Engineering Units/Min)	Any floating point number within the PV range
Monitor Broken Transmitter	YES-F3 or NO-F4.
PV is Bipolar	YES-F3 or NO-F4.
Monitor L-L/H-H Alarm	YES-F3 or No-F4
Monitor L/H Alarm	YES-F3 or NO-F4
Monitor Deviation Alarm	YES-F3 or NO-F4
Monitor Rate of Change Alarm	YES-F3 or NO-F4

Available Functions (continued)

The COPY Function Key

The COPY function key is used to copy information from one analog alarm to another. To begin the COPY operation, place the cursor on the alarm which will be copied. Once the cursor is positioned, press the COPY (F4) function key. The following prompt appears:

COPY FROM ALARM {alarm number} TO: 001

Type the number of the destination alarm over the number given on the screen. If you do not wish to continue with the COPY operation, use the ABORT (F1) function key. This terminates the operation.

Once the destination number for the analog alarm is typed, press the Return key to begin the operation. The alarm will be copied to the specified destination number unless an alarm already exists at that number. In this case, the following prompt will appear:

ALARM DATA {alarm destination number} ALREADY EXISTS

The available function keys change to an ABORT for the F1 function key and a REPLACE for the F2 function key. The ABORT function key stops the present attempt to copy and allows entry of another alarm number. The REPLACE function key will cause the COPY operation to continue, which results in the information in the destination alarm being overwritten.

The DEL Function Key

The DEL (DELe) function key removes the information for an alarm. To begin the DEL operation, place the cursor on the alarm number to be deleted. Once the cursor is positioned, press the DEL (F5) function key. The following prompt appears:

DELETE ALARM {number} : ARE YOU SURE

The functions shown at the bottom of the screen will change to a NO for the F1 function key and a YES for the F2 function key. If the NO function key is pressed, the DEL operation halts. If the YES function key is pressed, the DEL operation proceeds.

Programming Special Functions

6.1	Introduction	6-2
6.2	Available Functions	6-3
	The Movement Function Keys	6-4
	The DISPLAY Function Key	6-4
	SFSUB Header	6-5
	SFPGM Header	6-5
	The COPY Function Key	6-9
	The DEL Function Key	6-10
6.3	The Special Function Language	6-11
	Special Function Commands	6-11
	The Special Function Variables	6-15
	The Special Function Operators	6-19
6.4	Additions to the Modify and Insert Operations	6-22
6.5	Additions to the Find Operation	6-25

6.1 Introduction

The 565 Programmable Controller (P/C) provides two types of special function programming: Special Function Programs (SFPGMs) and Special Function Subroutines (SFSUBs). Figure 6-1 shows the menu hierarchy of the Special Function Programming. You may have up to 1023 Special Function Programs and up to 1023 Special Function Subroutines.

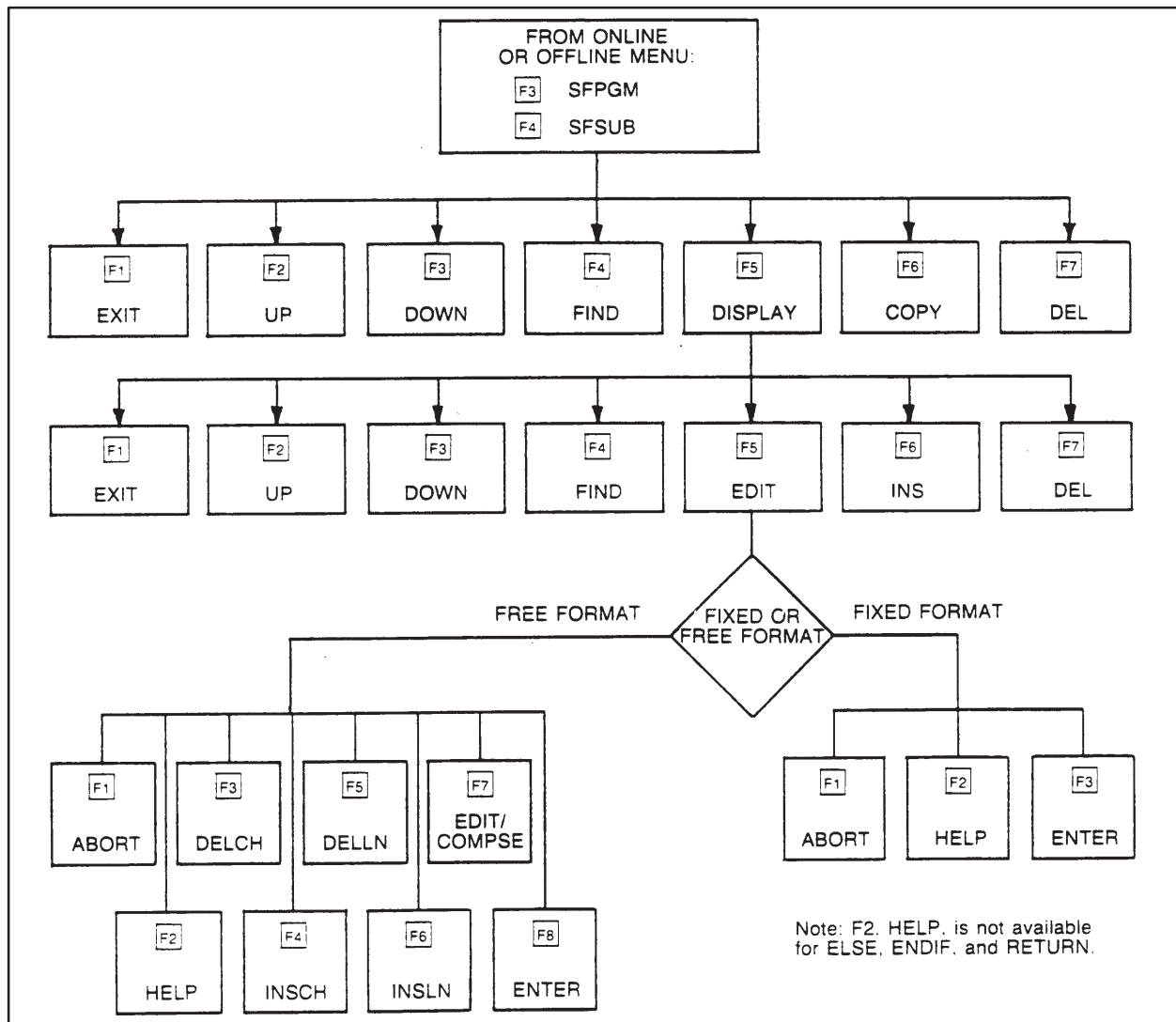

Figure 6-1 Accessing SF Programming Operation

6.2 Available Functions

When the SFPGM or SFSUB function key is pressed, either the first page of the Special Function Program Directory (SFPGM key pressed) or the Special Function Subroutine Directory (SFSUB key pressed) is displayed. Each page of the directory contains 32 entries. Figure 6-2 shows an example of the Special Function Program Directory. The function keys available from the directory are listed and described following the figure. These keys are the same in either a SFPGM or SFSUB directory.

SPECIAL FUNCTION PROGRAM DIRECTORY					
SFPGM	PROG	TITLE	SFPGM	PROG	TITLE
1	YES	ABCDEFGH	17	NO	
2	YES	MTR CTRL	18	YES	A B C D8
3	YES	PUMP 21A	19	NO	
4	YES	VLV P12	20	NO	
5	YES	EX 2	21	NO	
6	YES	ASDFGHJK	22	NO	
7	NO		23	NO	
8	NO		24	YES	ABC SAMP
9	YES	COMPUTE1	25	NO	
10	YES	FAN RM23	26	NO	
11	YES	PRINT V1	27	NO	
12	YES	CALC. SP	28	NO	
13	YES		29	NO	
14	YES	BURN X32	30	NO	
15	NO		31	NO	
16	NO		32	NO	

EXIT-F1 UP-F2 DOWN-F3 FIND-F4 DISPLAY-F5 COPY-F6 DEL-F7

Figure 6-2 Special Function Program Directory

EXIT	UP	DOWN	FIND	DISPLAY	COPY	DEL
F1	F2	F3	F4	F5	F6	F7

FUNCTION KEYS

The EXIT (F1) function key is used to return to the previous display.

Available Functions (continued)

The Movement Function Keys

There are three function keys used for moving through the pages of the directory. The UP (F2) function key displays the next page of the directory. The DOWN (F3) function key displays the previous page of the directory. The FIND (F4) function key is used to locate a specific program or subroutine in the directory.

When the FIND (F4) function key is pressed one of the following prompts appears (depending on whether you are in SFPGM directory or SFSUB directory):

FIND SFPGM: 0001

FIND SFSUB: 0001

The F1 function key is now ABORT to allow you to halt the FIND operation and return to the previous display.

To continue with the operation, type the desired program number or subroutine, and press the Return key. When the program or subroutine is found, the appropriate page of the directory is displayed on the screen with the cursor on the number requested.

The DISPLAY Function Key

The DISPLAY (F5) function key allows you to create or modify a program or subroutine. To begin the DISPLAY operation, place the cursor on the entry in the directory which you wish to create or modify. Once the cursor is positioned, press the DISPLAY function key. Figure 6-3 shows a sample SF program.

SF PROGRAM 5	TITLE = CONTINUE ON ERROR: (Y, N) PROGRAM TYPE (N, P, C, R) = ERROR STATUS ADDR: (C, Y, V, WY) CYCLE TIME (SEC) =	ABC SAMP N C V237 +1. 44005 E+04	} SFPGM HEADER
0001 CALL 0002 PACK 0003 IMATH 0004 IF 0005 IMATH 0006 ELSE 0007 MATH 0008 ENDIF 0009 IMATH 0010 PACK **** END **** EXIT-F1 UP-F2 DOWN-F3 FIND-F4 EDIT-F5 INS-F6 DEL-F7	SFSUB: 113 P1: T15. P2: WY1 P3: V100 P4: P5: TO FROM TABLE = T TABLE ADDR: T1 NUMBER OF POINTS = 8 DATA START ADDR: X1 T1 := T1 >> 8 T1 <= 0 T1 := -32767 T1 := TRUNC (LN (T1)) T1 := T1 << 8 TO/FROM TABLE = F TABLE ADDR: T1 NUMBER OF POINTS = 8 DATA START ADDR: Y9		

Figure 6-3 SF Program Example

SFSUB Header

The header for the SF subroutine consists of the number and title for the particular subroutine. The number is selected from the directory, and the title is added by following the procedure below.

1. Pressing F5 Display with the cursor positioned on the desired number in the directory;
2. Using the up arrow key to position the cursor in the header field of the display;
3. Pressing F5, Edit, to position the cursor in the title field;
4. Keying in the desired title. A maximum of eight characters can be used in a title.

SFPGM Header

The header for the program information is illustrated in Figure 6-3. The program number is assigned from the directory when the cursor is placed on that number and displayed. The title may be up to eight alphanumeric characters including any blanks, periods, and plus/minus signs. The cursor is positioned in the header field by using the UP arrow key as with SFSUBS. The remaining entries in the program information header are explained in the table below:

ENTRY NAME	AVAILABLE RESPONSES
Program Type (N,P,C,R)	Type the appropriate letter. 'N' stands for Non-priority, 'P' is Priority, 'C' is cyclic, and 'R' is Restricted (can be called only from Loops or Analog Alarms).
Error Status Addr (C,Y,V,WY)	Type the address of the variable to receive and store the error code when an error is encountered.
Cycle Time (Sec)	A value must be entered here in the range of .5 to 4095.5. (The entry will be ignored if C was not entered for program type.) The value must be to the nearest half-second.
Continue on Error(Y,N)	Type either 'N' for No or 'Y' for Yes.

When DISPLAY function key is pressed, the available function keys are then as shown and described in the following paragraphs.

Available Functions (continued)

EXIT	UP	DOWN	FIND	EDIT	INS	DEL
F1	F2	F3	F4	F5	F6	F7

FUNCTION KEYS

F1 EXIT This function key is used to keep all changes, terminate the DISPLAY operation, and return to the directory.

F2 UP This function key displays the next page of the program or subroutine if it exists.

F3 DOWN This function key displays the previous page of the program or subroutine.

F4 FIND This function key allows you to locate a specific statement in a program or subroutine. When the function key is pressed the following prompt appears:

FIND STATEMENT:

The F1 key is now ABORT; the F2, HELP. The ABORT function key stops the FIND operation and returns to the previous menu. The HELP function key displays a chart that lists all the commands in the special function library.

To begin the FIND operation, type the statement number or name next to the prompt and press the Return key. When the statement is found, the program or subroutine will be moved so that the statement is at the top of the screen.

If you wish to find the next occurrence of the statement, press the Return key once more. If the line or command is not found, "STATEMENT NOT FOUND" will be displayed. You must next either abort or enter a new line number or command.

F5 EDIT This function key is used to place the VPU200 in the mode for changing a particular statement in the program or subroutine. To begin the operation, place the cursor on the statement to be changed and press the EDIT function key.

The function keys which appear after the EDIT function key is pressed depends on the command which is being edited. For * (comment), IF, IMATH, MATH, and PRINT commands, the following function keys appear:

ABORT	HELP	DELCH	INSCH	DELLN	INSLN	EDIT/ COMPSE	ENTER
F1	F2	F3	F4	F5	F6	F7	F8

FUNCTION KEYS

These keys are used to manipulate lines and characters. The DELCH function key deletes the character under the cursor. The INSCH function key allows characters to be inserted. (Characters will continue to be inserted until the INSCH function key is pressed again or you quit the EDIT operation.) The DELLN deletes the line on which the cursor is placed. The INSLN inserts a line before the line on which the cursor is placed.

For the PACK command, the following function keys are available:

ABORT	HELP	DELLN	INSLN	ENTER
F1	F2	F3	F4	F5

FUNCTION KEYS

For the ELSE, ENDIF, and RETURN commands, the following function keys are available:

ABORT	ENTER
F1	F2

FUNCTION KEYS

Available Functions (continued)

For all other commands, only the following function keys are available:

ABORT	HELP	ENTER
F1	F2	F3

FUNCTION KEYS

The ABORT (F1) function key halts the EDIT operation and discards all changes. The HELP (F2) function key displays the special function library to help you find a particular command, variable, or operator. The ENTER function key keeps all changes and stops the EDIT operation.

To proceed with the EDIT operation, type the new parameter over the existing parameter. To move to the next parameter, press the right arrow key. If there are no parameters, enter the information as you desire. When all changes are made, press the ENTER function key to complete the operation and return to the DISPLAY menu.

F5 INS (INSert statement.) This function key will insert a line before the statement on which the cursor is placed. The line numbers will be renumbered to accommodate the new line once the new statement is entered.

F6 DEL (DELeTe statement.) This function key will remove the statement on which the cursor is placed. When the function key is pressed, the following prompt will appear on the screen:

DELETE STATEMENT: ARE YOU SURE

The available functions will change to a NO for the F1 function key and a YES for the F2 function key. Pressing the NO function key aborts the DEL operation; pressing the YES function key will cause the line to be deleted.

NOTE: Removing all lines from a program or subroutine will not delete the program or subroutine. To delete the entire program or subroutine, use the DEL function key which appears when the directory is displayed. See “The DEL Function Key” later in this section.

The COPY Function Key

The COPY function key is used to copy information from one program or subroutine to another. To begin the COPY operation, first place the cursor on the SFPGM or SFSUB which will be copied. Once the cursor is positioned, press the COPY (F6) function key. This will cause either of the following prompts to appear on the screen:

COPY FROM SFPGM {number} TO: 0001

COPY FROM SFSUB {number} TO: 0001

The cursor will be on the number of the source program or subroutine (that is, the one being copied), which appears at the right of the prompt. You should next type the number of the destination program or subroutine over the number on the screen. If you do not wish to continue with the COPY operation, use the ABORT (F1) function key. This function key allows you to terminate the operation and return to the original menu from which the COPY operation was begun.

Once the destination program number is typed, press the Return key to begin the operation. The program or subroutine will be copied to the specified destination unless the destination program or subroutine already exists. In this case, either of the following prompts will appear:

SFPGM {destination number} ALREADY EXISTS

SFSUB {destination number} ALREADY EXISTS

The available function keys will change to an ABORT for the F1 function key and a REPLACE for the F2 function key. The ABORT function key allows you to stop the present attempt to copy and enter another program or subroutine number. The REPLACE function key will cause the COPY operation to continue, which results in the information in the destination program or subroutine being overwritten (and therefore destroyed) by the new information. After the information is copied, the available functions will return to the menu in which the COPY function key appears.

Available Functions (continued)

The DEL Function Key

The DEL (DELe) function key erases a program or subroutine. To begin the DEL operation, first place the cursor on the program or subroutine which is to be deleted. Once the cursor is positioned, press the DEL (F7) function key. This will cause either of the following prompts to appear on the screen:

DELETE SFPGM {number} : ARE YOU SURE

DELETE SFSUB {number} : ARE YOU SURE

The function keys shown at the bottom of the screen will change to a NO for the F1 function key and a YES for the F2 function key. If the NO function key is pressed, the DEL operation will halt and the original menu will appear. If the YES function key is pressed, the DEL operation will proceed and the subroutine or program will be destroyed. After the DEL operation has completed, the previous menu will appear on the screen.

6.3 The Special Function Language

The language used for subroutines and programs is the same. This language is highly specific—as opposed to a more general language such as BASIC or FORTRAN. Each line of a program or subroutine is composed of the following elements:

- A line number (which is automatically assigned by the system)
- A command
- Variables and operators

These items are discussed in the following paragraphs in terms of VPU200 entry. For a more detailed discussion, please see the *SIMATIC 565 Programming Instructions Manual*.

Special Function Commands

The Special Function commands give instructions for certain operations to be performed. The following table lists the commands in alphabetic order and notes the operation the command performs.

The Special Function Language (continued)

Table 6-1 Special Function Language

COMMAND	MEANING
BCDBIN BCD INPUT BINARY OUTPUT	Converts a four-digit BCD value into a binary value.
BINBCD BINARY INPUT BCD OUTPUT	Converts a binary value into a four-digit BCD value.
* {comment} (Single, free format parameter)	Used to insert comments. This line is not executed when the program is run.
CALL {SFSUB number} {up to 5 parameters} (P1-P5 may be either integer or real constants, integer or real variables, or blank.)	Up to 5 parameters may be passed to the subroutine
CDT (Correlated Data Table) parameters: INPUT TABLE LENGTH INPUT TABLE OUTPUT TABLE OUTPUT	Locates an entry in one table which is equal to or greater than some input value. The corresponding entry in the output table is then placed in the specified output.
ELSE	This is used with 'IF' structures. It is used to start the series of statements which will be executed when the 'IF' statement is false.
ENDIF	Indicates the end of an 'IF-ELSE' structure.
FTSR-IN (Fall Thru Shift Register-Input) parameters: REGISTER LENGTH REGISTER START OUTPUT STATUS BIT	Adds an entry to an asynchronous shift register.
FTSR-OUT (Fall Thru Shift Register-Output) parameters: REGISTER LENGTH REGISTER START OUTPUT STATUS BIT	Removes an entry from an asynchronous shift register.

Table 6-1 Special Function Language (continued)

COMMAND	MEANING
<p>IF {conditional statement} (Single, free format parameter; variables and constants may be either integer or real; maximum field length of 74 elements, with an element being the smallest indivisible unit, such as a variable name, operator, constant, left parenthesis, right parenthesis, etc.</p>	<p>This command indicates the beginning of an 'IF' structure. For the operators which are used with this, see page 55. When the conditional element is true (non-0), all statements between the 'IF' and the 'ELSE' (or 'ENDIF' if no 'ELSE') will be executed. Otherwise the statements are ignored and the statements between the 'ELSE' and 'ENDIF' will be executed.</p>
<p>IMATH {expression} (Single, free format parameter; all variables and constants must be integer; subject to same restrictions as IF (above) for length.)</p>	<p>Used when performing integer math operations.</p>
<p>LEAD/LAG parameters: INPUT OLD INPUT OUTPUT LEAD TIME LAG TIME (Mins) GAIN (%/%)</p>	<p>Performs signal processing on an analog variable. In effect, the LEAD portion causes the output to be ahead of an input while LAG causes the output to be behind an input.</p>
<p>MATH {expression} (Single, free format parameter; variables and constants may be either integer or real; subject to same restrictions as IF (above) for length.)</p>	<p>Used when performing math operations.</p>
<p>PACK parameters: TO/FROM TABLE TABLE ADDRESS NUMBER OF POINTS DATA START ADDRESS</p>	<p>Moves discrete and word data to or from a table. You may use as many as 20 "DATA START..." parameters.</p>
<p>PACKAA parameters: parameters: ALARM NUMBER TO/FROM TABLE TABLE ADDR PARAMETERS</p>	<p>Moves analog alarm data to or from a specified table. Up to 8 parameters may be moved.</p>
<p>PACKLOOP parameters: LOOP NUMBER TO/FROM TABLE TABLE ADDR PARAMETERS</p>	<p>Moves loop data to or from a specified table. Up to 8 parameters may be moved.</p>
<p>PACKRS parameters: TO/FROM TABLE TABLE ADDR: LOOP NUMBER: NUMBER OF STEPS: STARTING STEP NUMBER:</p>	<p>Moves ramp/soak data to or from a specified table.</p>

The Special Function Language (continued)

Table 6-1 Special Function Language (continued)

COMMAND	MEANING
PRINT PORT MESSAGE: {place message here} (Free format; quotes required around text; variables separated by blanks; maximum field length is 1019 characters, with characters counted in entries as follows: each text character=1 character each variable entry=6 characters variable text entry=6 characters CR & linefeed=2 characters	Outputs a message to a printer.
RETURN	In a subroutine, this will cause execution to leave and return to the statement after the CALL statement in the SFPGM; in a program, it stops the program.
SCALE parameters: BINARY INPUT RESULT BIPOLAR 20% OFFSET LOW LIMIT HIGH LIMIT	Converts binary inputs into engineering units. The binary span is scaled to fit the engineering span.
SDT (Sequential Data Table) parameters: TABLE LENGTH INPUT TABLE TABLE PTR OUTPUT RESTART BIT	Sends the value at an address in the input table to the specified output address. A "pointer" determines what address is read in the input table, and it is incremented one address each time the command is used.
SSR (Sequential Shift Register) parameters: REGISTER LENGTH REGISTER START STATUS BIT	Shifts words in a table. The words are all moved one location, which creates a zero in the first location and causes the word in the last location to be discarded.
UNSCALE parameters: INPUT BINARY RESULT BIPOLAR 20% OFFSET LOW LIMIT HIGH LIMIT	Converts an input value in a certain range to an integer between 0 (or 6400 if 20% offset is used) and 32000 (or -32000 to 32000 if bipolar is used).

The Special Function Variables

Variable types are used in special function programming. Each type is an abbreviation for a parameter or variable in the 560/65 P/C. The variable must be followed by an identifying number for the particular parameter or variable indicated by the abbreviation. For example, "LERR" is the designation for loop errors. An identifying number must be added to the name to create a useable, correct variable. For example, "LERR34" would be a correctly identified variable.

Most variables may be either real or integer (although some, as noted in the chart which is included in this section, must be either one or the other.) A real variable is distinguished from an integer by placing a period (".") at the end of the variable name. For example, "AADB110." is a real variable, while "AADB110" is an integer variable.

Variables used in IF, IMATH, and MATH statements are allowed to have one subscript. The subscript may be either an integer or an expression which evaluates to an integer. (The expression may contain real variables for IF and MATH statements; for IMATH statements, the variables must be integers.) Lastly, the subscript is separated from the variable by parentheses.

The effect of the subscript is to cause the address of the variable to be offset by the amount of the subscript. For example, "V100.(WY256)" could be a variable used in a MATH statement. The effect of the subscript would be to change the address in V-memory: If WY256 is equal to 4, the variable would be interpreted as "V103."; if 9, the variable would be "V108.". In other words, the address in V memory is offset from V100. by the value of WY256. When the subscripts are numbers rather than memory locations, they are interpreted as shown in the following examples.

Reals	Integers
V100.(1)=V100.	V100(1)=V100
V100.(2)=V101.	V100(2)=V101
V100.(3)=V102.	V100(3)=V102
V100.(4)=V103.	V100(4)=V103

The following table gives the variables used in special function programming. The chart also shows what the abbreviation means, whether the variable may be real or integer (or both), and information which may help when using the variable in a statement. The symbol "ID#" which appears in the chart stands for identifying number and is followed by the range allowed for the identifying number. (If the symbol does not appear for a particular entry, the range for the variable is determined by the memory configuration.)

The Special Function Language (continued)

Table 6-2 Variable Types

VARIABLE	TYPE	MEANING	COMMENTS
AADB	Integer or Real	Alarm deadband for . . analog alarm	ID# is 1-128.
ACFH	Integer	Most-significant word of analog alarm C-flags	ID# is 1-128.
ACFL	Integer	Least-significant word of analog alarm C-flags	ID# is 1-128.
AERR	Integer or Real	Analog alarm error	ID# is 1-128. This is a read-only variable.
AHA	Integer or Real	High limit for analog alarm	ID# is 1-128.
AHHA	Integer or Real	High-high limit for analog alarm	ID# is 1-128.
ALA	Integer or Real	Low limit for analog alarm	ID# is 1-128.
ALLA	Integer or Real	Low-low limit for analog alarm	ID# is 1-128.
AODA	Integer or Real	Orange deviation for analog alarm	ID# is 1-128.
APV	Integer or Real	Analog alarm process variable	ID# is 1-128.
APVH	Real	High limit for analog alarm process variable	ID# is 1-128.
APVL	Real	Low limit for analog alarm process variable	ID# is 1-128.
ARCA	Real	Rate-of-change limit for analog alarm	ID# is 1-128.
ASP	Integer or Real	Analog alarm setpoint	ID# is 1-128.
ASPH	Integer or Real	High limit for analog alarm setpoint clamp	ID# is 1-128.
ASPL	Integer or Real	Low limit for analog alarm setpoint clamp	ID# is 1-128.
ATS	Real	Sample rate for analog alarm	ID# is 1-128.
AVF	Integer	Analog alarm V-flags	ID# is 1-128.
AYDA	Integer or Real	Yellow deviation for analog alarm	ID# is 1-128.

Table 6-2 Variable Types (continued)

VARIABLE	TYPE	MEANING	COMMENTS
C	Integer	Control relay	
DCP__S__	Integer	Drum count preset	The format for this must be: DCPnumSst, where 'num' is the drum number and 'st' is the step number (1-16):
DSC	Integer	Current drum step	
DSP	Integer	Preset drum step	
K	Integer or Real	K-memory	This is a read-only constant.
LADB	Integer or Real	Loop alarm deadband	ID# is 1-64.
LCFH	Integer	Most-significant word of loop C-flags	ID# is 1-64.
LCFL	Integer	Least-significant word of loop C-flags	ID# is 1-64.
LERR	Integer or Real	Loop error	ID# is 1-64. This is a read-only variable.
LHA	Integer or Real	High limit for loop alarm	ID# is 1-64.
LHHA	Integer or Real	High-high limit for loop alarm	ID# is 1-64.
LKC	Real	Loop gain	ID# is 1-64.
LLA	Integer or Real	Low limit for loop alarm	ID# is 1-64.
LKD	Real	Loop derivative Gain-Limiting Coefficient	ID# is 1-64.
LLLA	Integer or Real	Low-low limit for loop alarm	ID# is 1-64.
LMN	Integer or Real	Loop output	ID# is 1-64.
LMX	Integer or Real	Loop bias	ID# is 1-64.
LODA	Integer or Real	Orange deviation for loop alarm	ID# is 1-64.

The Special Function Language (continued)

Table 6-2 Variable Types (continued)

VARIABLE	TYPE	MEANING	COMMENTS
LPV	Integer or Real	Loops process variable	ID# is 1-64.
LPVH	Real	High limit for loop process variable	ID# is 1-64.
LPVL	Real	Low limit for loop process variable	ID# is 1-64.
LRCA	Real	Rate-of-change limit for loop alarm	ID# is 1-64.
LRSF	Integer	Loop ramp/soak flags	ID#is 1-64.
LSP	Integer or Real	Loop setpoint	ID# is 1-64.
LSPH	Integer or Real	High limit for loop setpoint clamp	ID# is 1-64.
LSPL	Integer or Real	Low limit for loop setpoint clamp	ID# is 1-64.
LTD	Real	Loop rate (derivative time)	ID# is 1-64.
LTI	Real	Loop reset (integral time)	ID# is 1-64.
LTS	Real	Loop sample rate	ID# is 1-64.
LVF	Integer	Loop V-flags	ID# is 1-64.
LYDA	Integer or Real	Yellow deviation for loop alarm	ID# is 1-64.
P	Integer or Real	Special function subroutine parameter	ID# is 1-5. Only allowed in SFSUBs.
STW	Integer	Status word	This is a read-only var.
T	Integer or Real	Temporary	ID# is 1-16.
TCC	Integer	Current count of a timer or counter	
TCP	Integer	Preset count of a timer or counter	
V	Integer or Real	V-memory	

Table 6-2 Variable Types (continued)

VARIABLE	TYPE	MEANING	COMMENTS
SFEC	Integer	Special Function Error Code	ID # is 1-1023
WX	Integer or Real	Word Input	This is a read-only variable.
WY	Integer or Real	Word output	
X	Integer	Discrete input	This is read-only
Y	Integer	Discrete output	

The Special Function Operators

There are three sets of operators in the special function programming language: those used in MATH statements, those used in IF-ELSE statements and those used in IMATH statements. These are listed in the following tables.

The Math Operators and Functions. For MATH statements, all basic arithmetic operations are allowed. These operations are shown below:

Table 6-3 Basic MATH Operations

OPERATOR	MEANING	OPERATOR	MEANING
**	Exponentiation	+	Addition/Unary Plus
*	Multiplication	-	Subtraction/Unary Minus
/	Division	:=	Assignment

The order that these operators will be performed in is left to right (except exponentiation, which is performed right to left) and in the following hierarchy: first exponentiation, then multiplication and division, and finally addition and subtraction. Note also that operators enclosed in parentheses will be performed before those which are not in parentheses.

The Special Function Language (continued)

In addition to the basic operators, MATH also supports several mathematical functions. These functions are shown below:

Table 6-4 Additional MATH Functions

FUNCTION	MEANING	FUNCTION	MEANING
ABS(X)	Absolute Value of X	FRAC(X)	Returns part of X to the right of the decimal point
ARCCOS(X)	Inverse Cosine of X	LN(X)	Natural logarithm of X
ARCSIN(X)	Inverse Sine of X	LOG(X)	Common logarithm of X
ARCTAN(X)	Inverse Tangent of X	ROUND(X)	Returns integer nearest X
CEIL(X)	Returns the smallest integer \geq to X	SIN(X)	Sine of X
COS(X)	Cosine of X	SQRT(X)	Square root of X
EXP(X)	"e" raised to the X	TAN(X)	Tangent of X
FLOOR(X)	Returns the largest integer \leq to X	TRUNC(X)	Returns integer part of X

NOTE: ALL TRIGONOMETRIC FUNCTIONS MUST BE IN RADIANS, NOT DEGREES.

The IF Operators. The operators used in the IF statements build on those used in MATH statements. All operators used in MATH statements except the "==" symbol are allowed in IF statements. Additionally, the following operators may be used in IF statements:

Table 6-5 IF Statement Operators

OPERATOR	MEANING	OPERATOR	MEANING
=	Equal	< >	Not Equal
<	Less Than	>	Greater Than
< =	Less Than or Equal	> =	Greater Than or Equal
OR	Logical OR	AND	Logical AND
NOT	Logical NOT		

When these operators are used in an IF-ELSE statement a 1 will be returned if the operator expresses a true relationship; otherwise a 0 will be returned.

The IMATH Operators. The IMATH operators are different from those used in MATH and IF statements. These operators should not be confused with the others as an error will result if the operators for one type of statement are used in a different type of statement. Also, no real variables or constants can be used with IMATH operators or the IMATH command. The operators which are supported for integer math are the following:

Table 6-6 IMATH Operators

OPERATOR	MEANING	OPERATOR	MEANING
*	Multiplication	+	Addition
/	Division (any remainder is discarded)	-	Subtraction
:=	Assignment (equals)	NOT	Take complement of
WAND	Logical, bit-by-bit AND of two words	WOR	Logical, bit-by-bit OR of two words
WXOR	Logical, bit-by-bit exclusive OR of two words	MOD	Modulo arithmetic: X MOD Y yields the remainder of X/Y
>>	Shift right	<<	Shift left

6.4 Additions to the Modify and Insert Operations

The basic MODIFY and INSERT functions are covered in the *VPU200/560 Programming Manual*. The 565 requires the addition of a SFPGM (Special Function Program) key to designate the SFPGMs to be used in the ladder program. Figure 6-4 shows the flowchart of the MODIFY and INSERT operations with the SFPGM incorporated.

Additions to the Modify and Insert Operations (continued)

As shown in the figure, the SFPGM function key is accessed by first pressing the MODIFY or INSERT function key and then pressing the BOX (F6) function key. When this key is pressed, the following function keys appear at the bottom of the screen:

ABORT	BIT	CTR/TMR	MATH	MOVE	WORD	DRUM	MATR	· +
F1	F2	F3	F4	F5	F6	F7	F8	(SPACE BAR)

FUNCTION KEYS

To access the SFPGM function key, press the spacebar. To return to the function keys shown above, press the spacebar.

6.5 Additions to the Find Operation

The FIND operation is altered so that it may be used to locate SFPGM boxes in your ladder logic program. Figure 6-5 shows the FIND operation with the additional function key. This function key is accessed by first pressing the FIND function key.

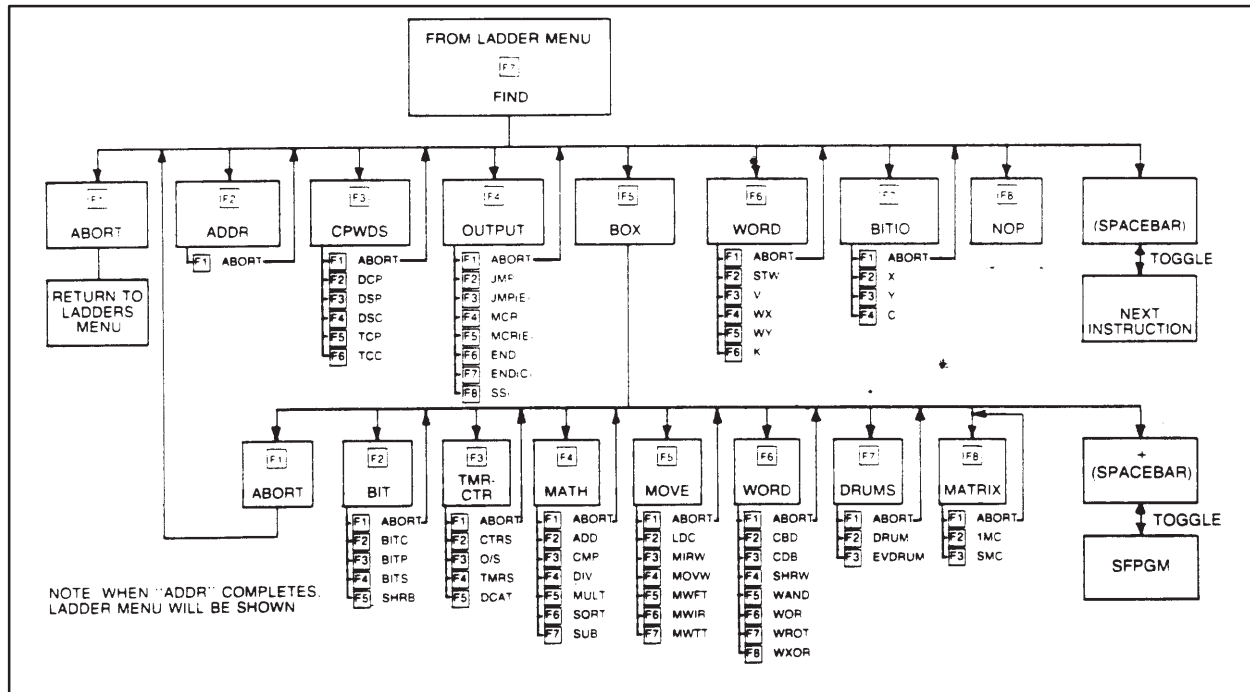

Figure 6-5 FIND Menu Hierarchy

From the function keys which then appear, press the BOX (F5) function key. The following function keys appear:

ABORT	BIT	CTR	MATH	MOVE	WORD	DRUM	MATRIX	+ (SPACE BAR)
F1	F2	F3	F4	F5	F6	F7	F8	

FUNCTION KEYS

The SFPGM function key appears when the spacebar is pressed. The F1 function key is assigned to the SFPGM box. Pressing the spacebar returns the previous display of function keys.

Chapter 7

Using Support Functions

7.1	Introduction	7-2
7.2	Complete Support Functions	7-4
7.3	Accessing Support Functions	7-5
	Support Functions 10–13 – P/C Restarts	7-5
	Function 14 – Watchdog Timer	7-5
	Function 15 – Software Part Number	7-6
	Function 17 – Compare P/C to Disk	7-6
	Function 18 – P/C Time of Day	7-9
	Function 19 – Set P/C Scan Time	7-9
	Function 20 – Run P/C Diagnostics	7-10
	Function 21 – Run Remote Base Diagnostics	7-10
	Function 25 – Display Failed I/O	7-10
	Function 27 – P/C Card Failure Class	7-11
	Function 29 – Show P/C Diagnostic Cell	7-12
	Functions 31–37, 74–77 – Clear P/C Memory	7-12
	Functions 60–67 – Save P/C	7-13
	Functions 90–99 – Load P/C	7-13
	Function 81 – Select P/C Mode	7-14
	Function 82 – Hot Back Up	7-14
7.4	Accessing Auxiliary Support Functions	7-16

7.1 Introduction

Support functions are available at two locations in the menu hierarchy. The first menu contains the complete support functions and is accessible after loading the operating system disk. (Figure 7-1). The second menu, Auxiliary Support Functions, is reached from the primary operations menu (Figure 7-2). The Auxiliary Support Functions Menu contains only those functions for clearing P/C memory, restarting the P/C, displaying P/C errors and setting scan time.

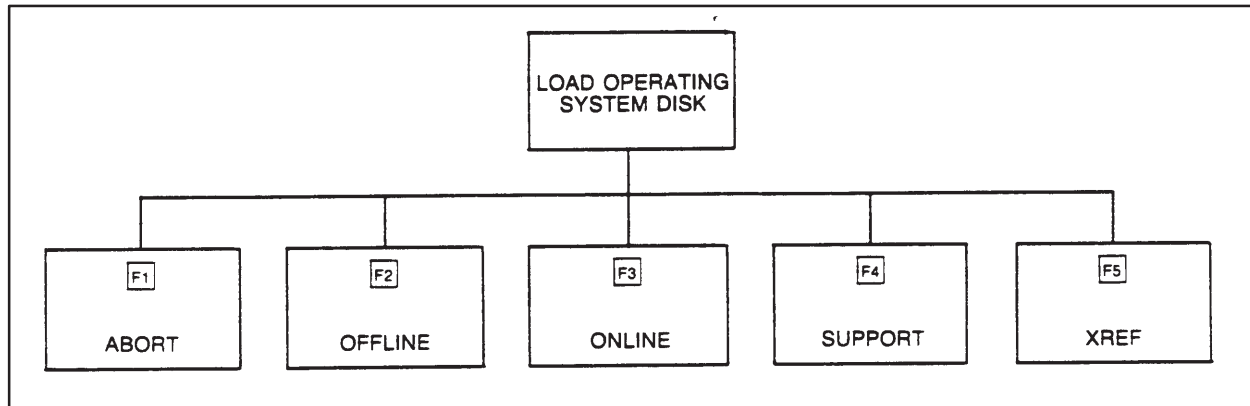

Figure 7-1 Accessing Support Functions Menu

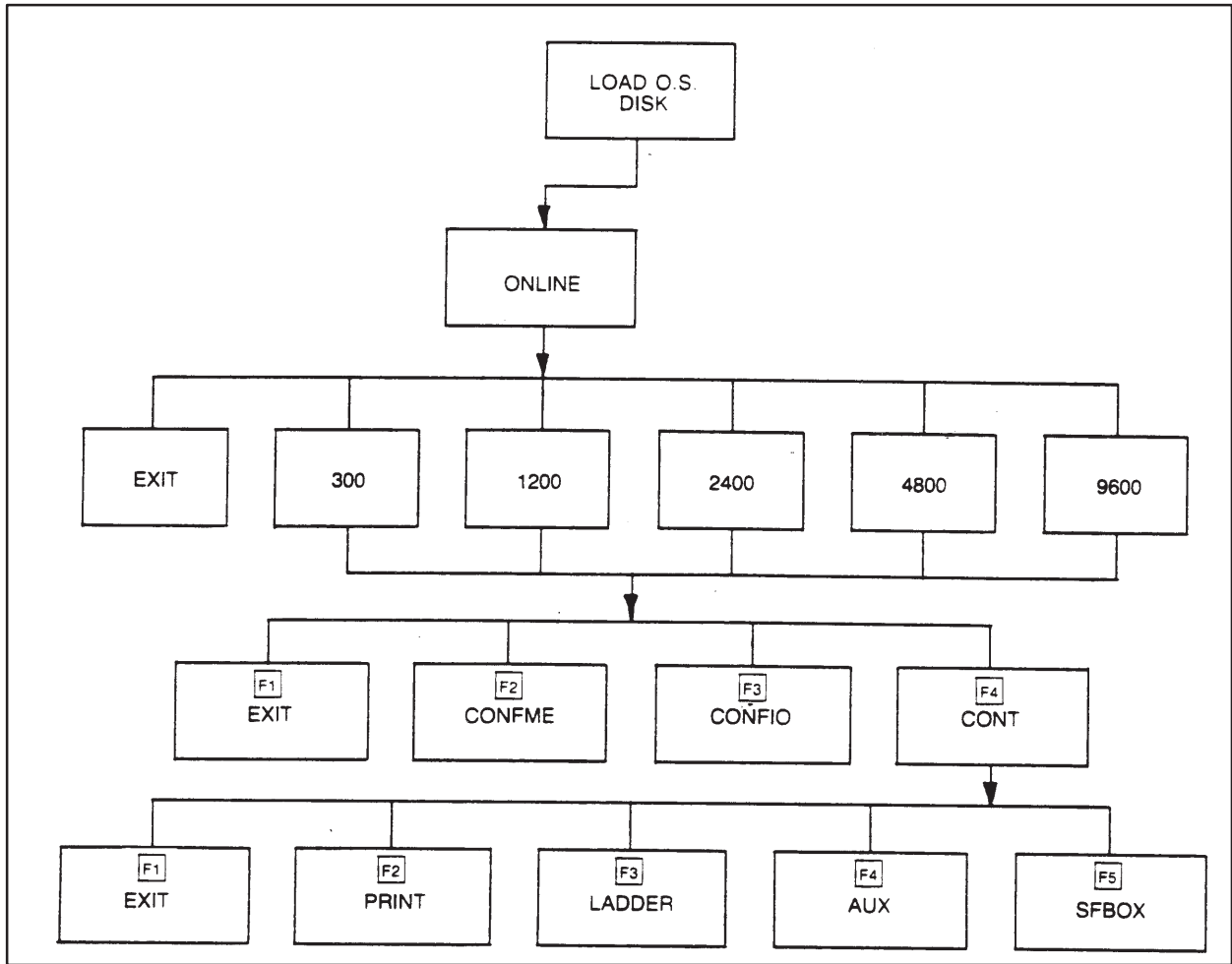

Figure 7-2 Accessing Auxiliary Support Functions Menu

7.2 Complete Support Functions

As described at the beginning of the section, complete support functions are accessed by pressing the support (F4) function key after loading the operating system disk. The VPU200 enters the online mode of operation and loads the support operating system upon selection of the support functions. After selection of baud rate, the first page of the Support Function menu is displayed as shown in Figure 7-3.

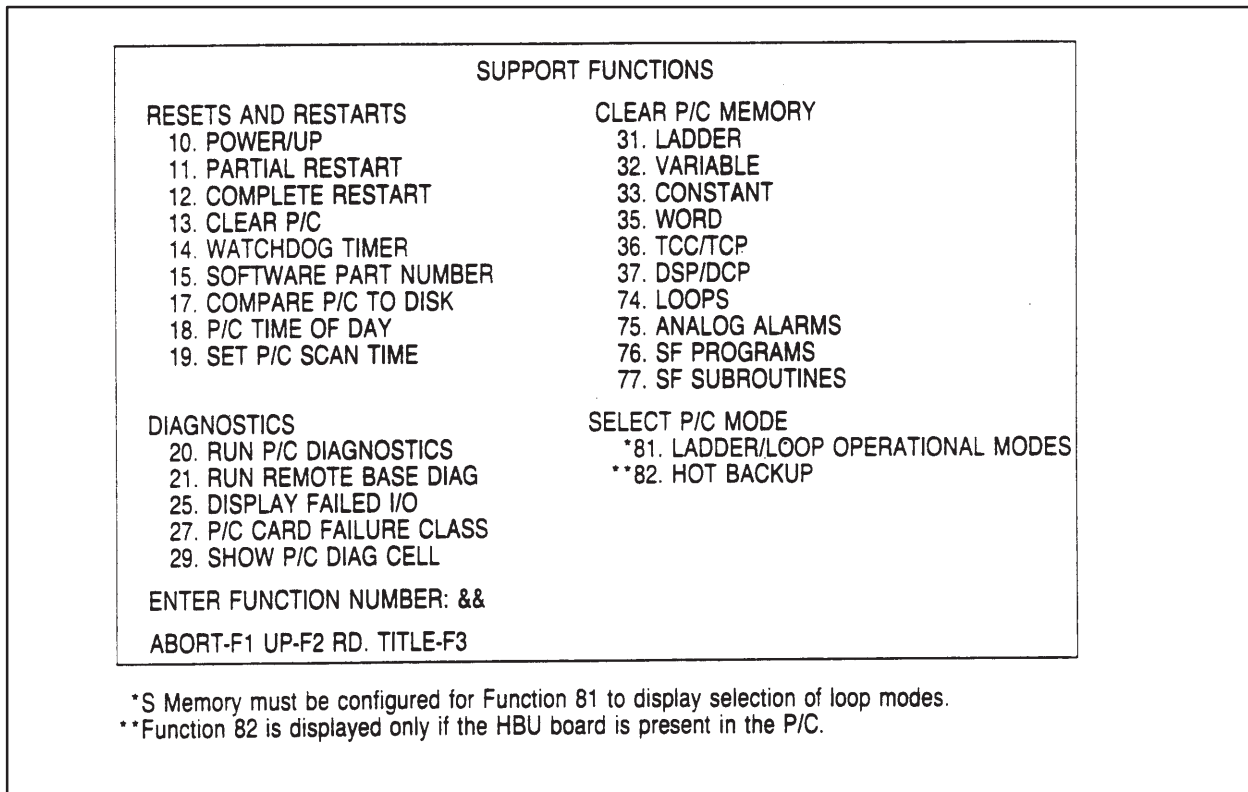

Figure 7-3 Support Functions Menu, page 1

7.3 Accessing Support Functions

To initiate one of the functions, type the number of the desired function next to the prompt on the screen of the VPU200. Then press the Return key to begin the function. The system will prompt for more information if it is needed. To leave the SUPPORT function, press the ABORT (F1) function key.

Support Functions 10–13 – P/C Restarts

These four functions are used to reset (or restart) the P/C. Each of the four functions clears a certain portion of memory. (A “cleared” memory is one in which all values are set to zero.) The following describes which portions of memory will clear for each of the functions:

Function 10 (Power-up Restart) clears all discrete registers (that is, the registers for X, Y, and C elements) except those which are forced. The word registers (WX and WY elements) will not be affected. Note, however, that if the battery is low or missing, all registers including forced and word elements will be cleared, as well as ladder logic, memory configuration and I/O configuration.

Function 11 (Partial Restart) clears all discrete registers except retentive-C and forced elements. The word registers and presets will not be reset to zero.

Function 12 (Complete Restart) clears all discrete registers (including retentive-C elements). Forced elements and word registers will not be reset to zero.

Function 13 (Clear P/C) places the P/C in program mode, sets the scan to 50 milliseconds, and clears all memory locations including the ladder logic program.

After the number of the function is entered by pressing the Return key, the screen will repeat the name of the function and ask whether you are sure you wish that function performed.

If you press the F1 (NO) function key, the system will abort the selected function and return to the screen which shows the menu for the support functions. If you press the F2 (YES) function key, the system will begin the requested function. When the requested function is complete, the system will return to the menu showing the available support functions.

Function 14 – Watchdog Timer

Function 14 (Watchdog Timer) allows you to set and read the timer. The timeout range that may be entered from the VPU is from 0 to 32767 milliseconds. (However, the minimum timeout supported by the P/C is 500 msec.) When the Watchdog Timer function is selected, the function keys available are displayed, along with the watchdog timer value. The Support Function menu remains in the upper part of the display.

Accessing Support Functions (continued)

Function 15 –
Software Part
Number

Function 15 (Software Part Number) obtains the part number of each of the printed circuit boards currently installed in the P/C. The part numbers will be displayed next to a number indicating the slot in which the board is installed. Note that for the Global Memory Card, the slot number in which the card is installed will be followed by blanks. After completion of the function, press the EXIT (F1) function key to return to the screen showing the available support functions.

Function 17 –
Compare P/C to
Disk

Function 17 (Compare P/C to Disk) allows a comparison of the data on disk to that in the P/C. When Function 17 is used the first time, a message informs you that no verification file has been found. (See the descriptions of SAVE-F2 and LOAD-F3 given below.) In order to continue the verification operation, press the CONTINUE-F2 key. If Function 17 has been used before and a file saved, the VPU proceeds directly into the function. Figure 7-4 shows the menu that appears the first time Function 17 is called.

VERIFICATION FUNCTION		
TYPE	MEMORY	STATUS MODIFIED LOCATIONS
	LADDER NETWORKS	
	FORCED WORD I/O	
	FORCED DISCRETE I/O	
	SEQUENCER SCAN TIME	
	FORCED CONTROL RELAYS	
	SEQUENCER SCAN TIME	
	LOOPS	
	ANALOG ALARMS	
	SF PROGRAMS	
	SF SUBROUTINES	
	V-MEMORY	
	V-MEMORY	
	V-MEMORY	
	V-MEMORY	
SELECT P/C MEMORY TO BE COMPARED AGAINST DISKETTE		
ABORT-F1 SAVE-F2 START-F3 VERIFY-F4 IGNORE-F5 EXAMINE-F6		

Figure 7-4 Compare P/C to Disk Menu

Function 17 Fields Defined. The fields available in the Function 17 menu are defined as follows:

- **Type** – The default for this field is I, Ignore which tells the VPU to ignore this memory category. The other options for this field are V, Verify, or E, Examine.
- **Memory** – The memory category to be verified or examined is listed in this field.
- **Status** – After verification or examination, the VPU displays in this field whether the memory type passed or failed the comparison.
- **Modified Locations** – The VPU lists in this field the memory addresses of ladder logic or the numbers of the discrete elements that fail the compare. For the Verify function, only the first failure is listed. With the Examine function, at the fourth error found, the VPU operator is given the option to continue the search or go to the next memory category. The Sequencer Scan Time and Ladder Networks categories are treated differently from the other options. Since there is only one memory location for the scan time information, a passed or failed status only is indicated. If the status is failed, a 1 is listed in the Modified Locations field. When the Ladder Networks are verified, only the address of the first modified rung is listed in the Modified Locations field.

The four arrow keys on the VPU are used to move the cursor from field to field for selection and entry of the type of compare to perform on a particular memory category. The function keys shown in Figure 7-4 are listed and described below.

Accessing Support Functions (continued)

The function keys are defined below.

F1	ABORT	Before the compare operation is begun, the F1 key returns the display to the Master Support Functions menu. After the compare is initiated, F1 returns the display to the Function 17 menu.
F2	SAVE	The F2 key saves the options selected to the program disk.
F3	LOAD	The F3 keys displays the last screen loaded to disk.
F4	START	The F4 key initiates the compare function you select.
F5	VERIFY	The Verify F5, key tells the VPU to compare a memory category in the P/C to the same memory category on the disk. This is the key used for entry in the Type field as described above.
F6	IGNORE	The Ignore, F6, key is entered in the Type field for any memory categories that are not to be examined or verified.
F7	EXAMINE	When the F7 key, Examine, is entered in the Type field, the compare function works as described above.

Note the following distinctions between the Verify and Examine operations.

- The Verify function compares a memory category (other than Ladder, which is described below) and stops after finding three differing locations. The addresses of the first two differing locations are displayed, and “...” is displayed in the far right column to indicate additional differences exist. The compare function then continues to the next selected memory category.
- The Examine function does not stop after one comparison failure. It displays the differing location and continues comparing the same memory category. After four mismatched locations, a prompt appears to ask if you want to continue or abort the operation.
- For Ladder memory, verify requires that networks be at the same address in the P/C and on the disk, and stops after the first location that differs. The Examine function does not require networks to be at the same address (more no-ops could appear on either the disk or in the P/C).

Function 18 – P/C
Time of Day

Function 18 (P/C Time of Day) allows you to read and/or set the current time. After the function is initiated by typing the number, pressing the Return key, and answering Yes to the prompt, the following line will appear on the screen:

YEAR= MONTH= DAY= HOUR= MINUTE= SECOND= DAY OF WEEK=

The areas next to each entry on the line will contain the appropriate number to signify the date, the time, and the day of the week. Note that the hour is expressed in 24-hour format, and that the day of the week is a number between 1 and 7. The function keys which are available will also change to the following:

EXIT	READ	WRITE
F1	F2	F3

FUNCTION KEYS

The EXIT (F1) function key terminates this auxiliary function and returns to the screen showing the support function menu. The READ (F2) function key is used to obtain the current time from the P/C. The time is set by moving the cursor to the appropriate entry, typing the desired information, and then pressing the WRITE (F3) function key. If the information which was typed is invalid, the system will not allow the new time to be entered when the WRITE function key is pressed.

Function 19 – Set
P/C Scan Time

Function 19 (Set P/C Scan Time) allows you to set the scan time for the P/C. After the function is entered by pressing the Return key, the screen will show the phrase "SCAN TIME =" followed by the scan time in milliseconds. If the scan time is variable, the word "VARIABLE" will appear after the value for the scan time. To set the scan time, type the new scan time and press the Return key. Or, if you want to have variable scan time, type zero and press the Return key.

Accessing Support Functions (continued)

Function 20 – Run P/C Diagnostics

Function 20 (Run P/C Diagnostics) will cause the system to respond with “RUN P/C DIAGNOSTICS: ARE YOU SURE?” and the following function keys at the bottom of the screen:

NO	YES
F1	F2

FUNCTION KEYS

If you press the NO (F1) function key, the system will abort the auxiliary function and return to the screen showing the available auxiliary functions. If instead you press the YES (F2) function key, the system will instruct the P/C to begin its self-diagnostics. If the diagnostics pass, the phrase “P/C PASSED SELF-DIAGNOSTICS” will be shown. If the diagnostics fail, a message giving the reason for the failure is displayed.

Function 21 – Run Remote Base Diagnostics

Function 21 (Run Remote Base Diagnostics) allows you to perform diagnostics on remote bases. You may select a particular channel and base for running the diagnostics, or you may choose to run the diagnostics on all channels and bases. When the function is started, a prompt will appear to ask if you are sure. If you press the NO (F1) function key the function will abort, and the function chart will reappear on the screen. If you press the YES (F2) function key, the function will begin. When the diagnostics are complete the channel and bases will be displayed with “DIAGNOSTICS PASSED” or an error message explaining why they failed. Also, the function keys will change to EXIT (F1) and CONTINUE (F2). The EXIT function key will terminate the function; the CONTINUE function key will show the next page of channels and bases (if any).

Function 25 – Display Failed I/O

Function 25 (Display Failed I/O) will cause the system to assess the status of all I/O modules attached to the system. It will then display in chart format the location (in the order of Channel, Base, and Slot) of any failed I/O modules. The following function keys will appear at the bottom of the screen:

EXIT	CONTINUE
F1	F2

FUNCTION KEYS

If the list of failed I/O modules will display on one screen, the CONTINUE (F2) function key does not appear. If more than one display is required to show all the failed I/O modules, CONTINUE (F2) function key will place the next page of failed I/O modules on the screen. Note that this function works only for those I/O modules that drive the F bit (the module Fail bit). To determine if the F bit is used in the module you wish to check, see the manual for that particular module. When you wish to leave this function, pressing the EXIT (F1) function key terminates the function and returns the support menu to the screen.

Function 27 – P/C Card Failure Class

Function 27 (P/C Card Failure Class) allows you to specify whether or not failure of a particular board (card) will cause the system to fail. After selecting Function 27 from the menu, a display listing the P/C slot, type of board, and failure class, is shown as illustrated in Figure 7-5.

P/C CARD FAILURE CLASS		
P/C SLOT	P/C CARD	FAILURE CLASS
1	CPU	FATAL
2	GLOBAL MEMORY	FATAL
3	RCC	NON-FATAL
4	LOOP	NON-FATAL
ABORT-F1 FATAL-F2		

Figure 7-5 Example Listing of P/C Card Failure Class

The card failure class listing will only show slot numbers that contain boards. To change the class of a board, use the UP/DOWN arrow keys to position the cursor in the failure class field for the board to be changed. Use the F2 key to change the failure class field from “FATAL” to “NON-FATAL” or vice versa. After F2 is pressed, the displayed failure class of the board will change to the new class. Some boards must be classed as “FATAL,” and cannot be changed. If a change is made to one of these, the message “CARD MUST BE FATAL,” is displayed.

Accessing Support Functions (continued)

Function 29 – Show P/C Diagnostic Cell

Function 29 (Show P/C Diagnostic Cell) will obtain the diagnostic cell from the P/C. The function will then display the cell on the screen in the form shown in Figure 7-6.

```
565 OPERATIONAL STATUS

SCAN = 027 SECS/FIXED
KEY = UNLOCKED
MODE = RUN
S MEMORY CONFIGURED = 10240

S/F LOOP MODE = RUN
SF/LOOP FOLLOWS P/C TO PROGRAM MODE

FATAL ERROR = NONE
LOOP FATAL ERROR = NONE
NON FATAL ERROR = NONE
LOOP NON FATAL ERROR = NONE

BATTERY = GOOD
DOWNLOAD = OFF
PROGRAM IN RAM
S MEMORY AVAILABLE = 3720
```

Figure 7-6 Result of Function 29

When loop errors are displayed, use F2 to clear them. After F2 is pressed, the display appears as shown above with loop errors listed as NONE. If an error occurs on a communication port or a control block, neither of these will clear until the problem is corrected. (See Appendix A.) To leave this auxiliary function, press the EXIT (F1) function key. This will return the system to the menu displaying the available functions.

Functions 31–37,
74–77 – Clear P/C
Memory

The remaining functions on page 1 of the support menu clear P/C memory as indicated by their names. After the number of the auxiliary function is entered by pressing the Return key, the screen will repeat the name of the function and ask whether you are sure you wish that function performed.

If you press the F1 (NO) function key, the system will abort the function and return to the menu showing the available functions. If you press the F2 (YES) function key, the system will begin the requested function. When the requested function is complete, the system will return to the menu showing the available auxiliary function keys.

NOTE: Some functions cannot be performed in the RUN mode. The VPU will return the message, Illegal Request in Current Operational Mode, if a function is requested that cannot be performed unless in PROGRAM mode.

SUPPORT FUNCTIONS	
SAVE P/C	LOAD P/C
60. ALL	90. ALL WITHOUT IR
61. LADDER	91. LADDER
62. VARIABLE	92. VARIABLE
63. CONSTANT	93. CONSTANT
64. LOOPS	94. LOOPS
65. SNSLOH SLSTMD	95. ANALOG ALARMS
66. SF PROGRAMS	96. SF PROGRAMS
67. SF SUBROUTINES	97. SF SUBROUTINES
	98. FORCED IR
	99. WORD I/O
ENTER FUNCTION NUMBER: &&	
ABORT-F1 DOWN-F2 RD. TITLR-F3	

Figure 7-7 Support Functions Menu, page 2

**Functions 60–67 –
Save P/C**

Functions 60–67, Figure 7-7, are used to save data from the P/C to a VPU disk. The memory type saved is indicated by the name of the function; e.g., All, Ladder, etc.

Enter the number corresponding to the type of memory you wish to save; press Return. A prompt asks whether you are sure you wish that function performed. If you press F1(NO), the function is aborted. Pressing F2(YES) begins the requested operation.

Note that for Function 60, “ALL” means that Ladder Memory, V-Memory, K-Memory, Word I/O, Forced Word I/O/OF Discrete I/O, Forced Discrete I/O Loops, Analog Alarms, SF Programs, SF Subroutines, I/O Configuration for all bases and channels, Memory Configuration, and Scan Time will be saved to disk.

**Functions 90–99 –
Load P/C**

Functions 90–99, Figure 7-7, are used to load data from the VPU disk to the P/C. The memory type loaded is indicated by the name of the function: e.g., All without IR, Ladder, Variable, etc.

Enter the number corresponding to the type of memory you wish to load to the P/C; press Return. A prompt asks whether you are sure you wish that function performed. If you press F1 (NO) the function is aborted. Pressing F2 (YES) begins the requested operation.

Function 90, Load without IR, loads Ladder Memory, V-Memory, K-Memory, Scan Time, Loops, Analog Alarms, SF Programs, SF Subroutines, I/O Configuration for all bases and channels, and, Memory Configuration. It does not load Word I/O, Forced Word I/O, Discrete I/O, nor Forced Discrete I/O.

Function 98, Forced IR, loads Forced Word I/O (WX, WY) and Forced Discrete I/O (X, Y, C).

Accessing Support Functions (continued)

Function 99, Word I/O, loads Forced and Unforced Word I/O, (WX, WY).

NOTE: To save or load a specific memory type (V-memory, K-memory, etc.), the Memory Configuration in the P/C and on the disk must be identical. Save All (Function 60) copies the memory configuration from the P/C to the VPU disk. Load All without IR (Function 90) copies the memory configuration from the VPU disk to the P/C.

Function 81 – Select P/C Mode

Function 81 (Select P/C Mode) is available for selecting the operational modes of the ladder and loop operations. After selecting Function 81 from the menu, you have three fields available for choosing modes. Place the cursor in the desired field, illustrated below, and press the function key for that field to change the operating mode.

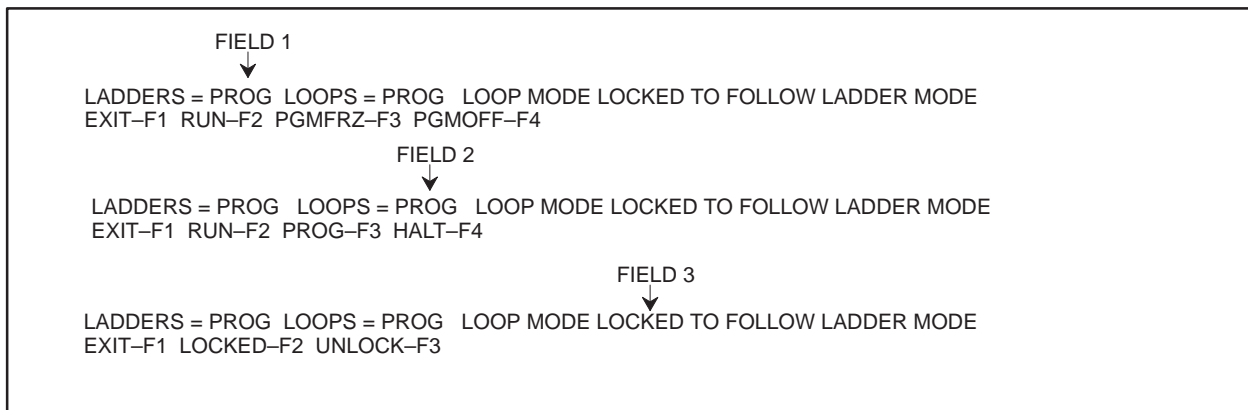

After changes are entered, all altered fields show the new data; and the cursor returns to Field 1. If an error occurs, a message is displayed; and the cursor remains where the error occurred.

Function 82 – Hot Back Up

Function 82 (Hot Back Up) is used for examining or modifying the HBU status. After Function 82 is selected, a menu is displayed. The following illustration contains sample entries that may appear.

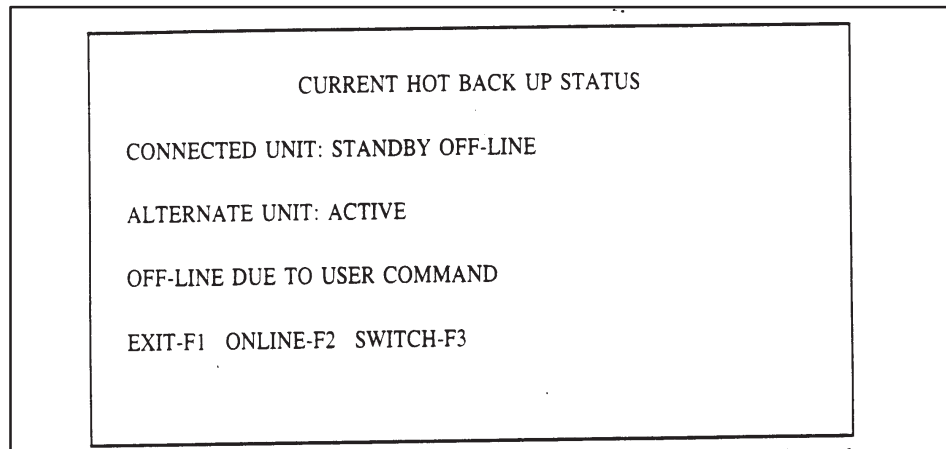

This menu displays the current status of the active and standby units and provides the function keys to change status. In addition, if the standby unit is offline, one of the following messages is displayed to give the reason.

- State entered at power-up
- Offline due to Hardware Mismatch
- Offline due to User Command
- Offline due to Active unit in PROGRAM mode
- Offline requesting online but inhibited by user program in active Unit
- Offline due to failure in Standby
- Offline due to loss of HBU Communications

7.4 Accessing Auxiliary Support Functions

As shown in Figure 7-2 at the beginning of this section, the Auxiliary Support Functions are accessed at the System Operations Menu. Pressing F4 (AUX) displays the menu shown in Figure 7-8.

AUXILIARY SUPPORT FUNCTIONS

<p>RESETS AND RESTARTS</p> <ul style="list-style-type: none">10. POWER/UP11. PARTIAL RESTART12. COMPLETE RESTART13. CLEAR P/C14. WATCHDOG TIMER19. SET P/C SCAN TIME <p>DIAGNOSTICS</p> <ul style="list-style-type: none">25. DISPLAY FAILED I/O27. P/C CARD FAILURE CLASS29. SHOW P/C DIAG CELL	<p>CLEAR P/C MEMORY</p> <ul style="list-style-type: none">31. LADDER32. VARIABLE33. CONSTANT35. WORD36. TCC/TCP37. DSP/DCP74. LOOPS75. ANALOG ALARMS76. SF PROGRAMS77. SF ROUTINES <p>SELECT P/C MODE</p> <ul style="list-style-type: none">*81. LADDER/LOOP OPERATIONAL MODES**82. HOT BACKUP
---	--

ENTER AUXILIARY FUNCTION NUMBER: &&

ABORT-F1

* S memory must be configured for Function 81 to display selection of loop modes.
** Function 82 is displayed only if the HBU board is present in the P/C.

Figure 7-8 Online Auxiliary Support Functions Menu

The auxiliary support functions are a subset of the complete support functions described in the preceding paragraphs. Each auxiliary function operates in this menu just as it does in the complete support functions menu.

Chapter 8

Printing

8.1	Introduction	8-2
8.2	Configuring the Parameters for Printing	8-4
8.3	Operation of the Print Key	8-6
8.4	Operation of the Print Function Key	8-7
	Printing while in the Online Mode	8-7
	Memory Configuration	8-8
	I/O Configuration	8-8
	Ladders	8-8
	Printing while in the Offline Mode	8-8
	Synonyms	8-9
	Memory Configuration	8-9
	I/O Configuration	8-10
	Ladders	8-10
8.5	Interrupting the Print Operation	8-11
8.6	Printing Cross-References	8-13

The printing function is accessed from two locations in the menu hierarchy. The first, Print Cross-References, is on the initial menu after loading the operating system disk. The other print operations are accessed from the system operations menu. Flowcharts illustrating the locations of the print function keys are included with the detailed explanations which follow.

In addition to the function keys for the print operation, a Print key is available on the VPU200 keyboard. The Print key may be used any time, except during the print operation, to print the currently displayed screen.

After pressing the PRINT (F2) function key, the arrangement of the function keys in the PRINT hierarchy is as shown in Figure 8-1. The PRINT function key appears on the screen of the VPU200 rather than on the keyboard and is used to print entire groups of related information (such as Memory Configuration charts, ladder logic programs, and synonyms).

Note that the mode of operation is important when using the PRINT function key. The principal difference between the two modes is that synonyms and comments can only be printed in the Offline mode. All other categories may be printed regardless of the mode of operation.

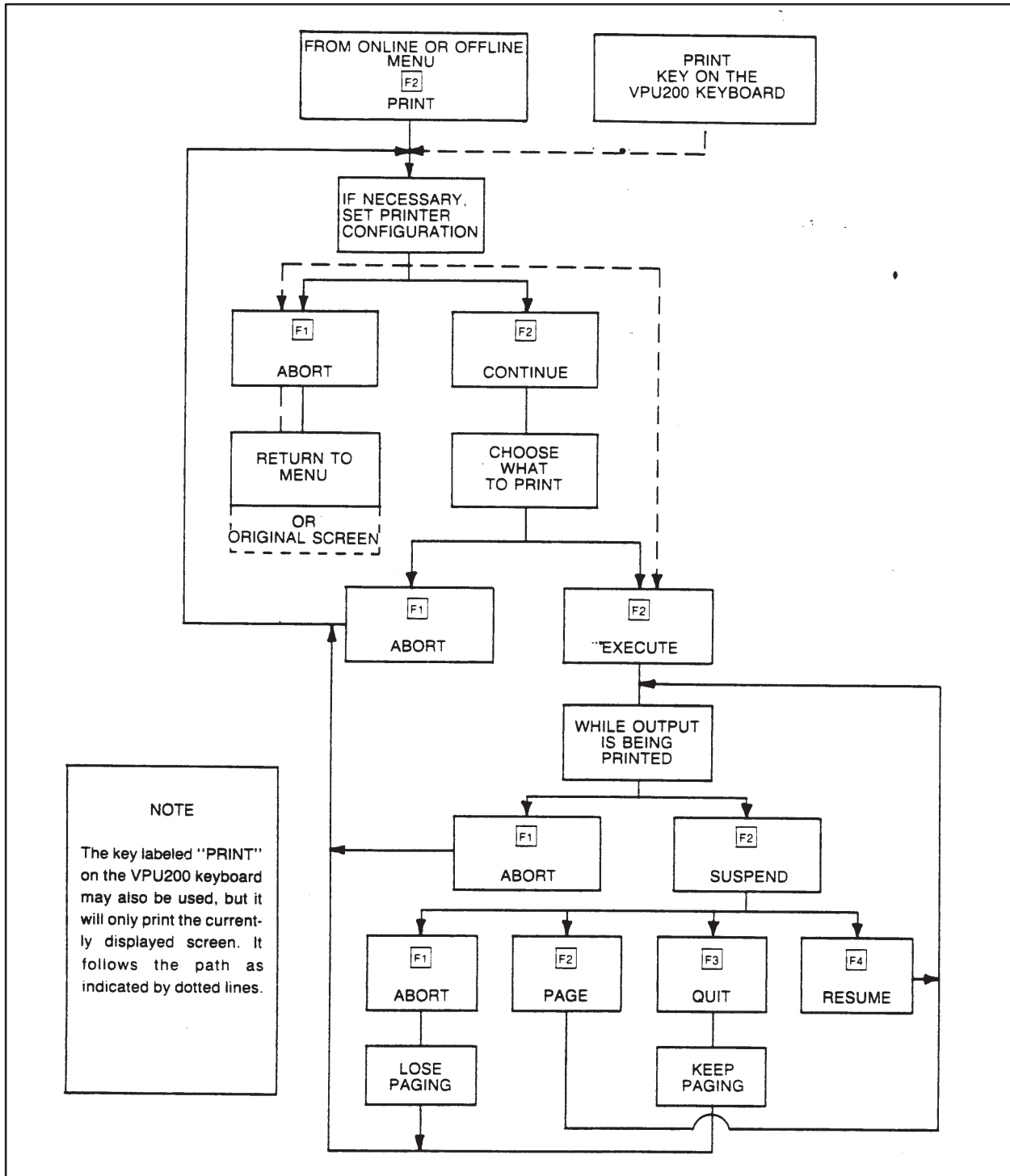

Figure 8-1 Print Hierarchy

8.2 Configuring the Parameters for Printing

The first step is to set the parameters for printing. Once the parameters are set, they will remain until you modify them.

After the Print key or the PRINT function key is pressed, the configuration chart for printing is displayed. This chart and the default values for the entries in the chart are shown in Figure 8-2. (If the parameters have previously been created, these values will be shown in the chart.)

COLUMNS	72	80	80
BAUD RATE	110	300	600	
	1200	2400	4800	9600
9600
LINES PER PAGE	66	70	66
DATE	00-00-00
PRINT RIGHT RAILS	YES	NO	YES

Figure 8-2 Printing Parameters

To select parameters from the chart, use the arrow keys on the VPU200 keyboard to move to the desired category and then place the cursor on the parameter for the category that you want. Once the cursor is on the desired parameter, press the Return key to choose that parameter. This will also place the chosen parameter on the right side of the chart and move the cursor to the next category.

For example, if you wanted to change the baud rate from 300 to 4800 baud, you would place the cursor on the “4800” parameter under the “BAUD RATE” category. Then you would press the Return key, which would change the baud rate and show it on the right side of the screen.

NOTE: To set the date, place the cursor on the first position of the date entry and type the numerical equivalent of the month; next, move the cursor to the next position and type the day; finally, move the cursor to the last position and type the last two digits of the year.

The following list describes what each of the parameters controls:

1. **COLUMNS:** This sets the width of the printed page. Note that if 72 is chosen here, the PRINT RIGHT RAILS entry will automatically be set to NO.
2. **BAUD RATE:** This controls the rate of communication to the printer and should be set the same as on the printer.
3. **LINES PER PAGE:** This sets the length of the printed page.
4. **DATE:** This sets the date in the order of Month, Day, and Year which will be shown on the printout.
5. **PRINT RIGHT RAILS:** This parameter is used to specify whether ladder logic diagrams will be printed with the right rail (which is the long vertical line which joins the networks together). Note that if 72 was chosen for the number of columns, only NO will be allowed for this entry.

8.3 Operation of the Print Key

The Print key on the VPU200 keyboard may be used at any time except while the PRINT operation is in effect. It is used to print the currently displayed screen. This section will describe the steps necessary to print a displayed screen.

Once you reach a screen which you wish to print, press the Print key on the keyboard. The printing parameters chart appears. If the parameters for printing have not been set or need to be changed, enter them as previously explained in the paragraph on configuring print parameters. If the chart is correct, proceed with the print operation by pressing the EXECUTE (F2) function key. This will begin the printing of the displayed screen. The phrase, PRINT SCREEN, will appear while the operation is in progress. When the print operation is complete, the original display appears.

8.4 Operation of the Print Function Key

The following types of printouts can be obtained by using the Print Function key.

- Memory Configuration charts
- I/O Configuration charts (with synonyms if in the Offline mode)
- Ladder Diagrams (with synonyms and comments if in the Offline mode)
- Synonym listings (if in the Offline mode)

As can be seen from the list above, the mode of operation is important in this operation. Before proceeding with the print operation, be sure you are in the correct mode for what you wish to print.

Printing while in the Online Mode

When you first press the PRINT function key, the printing parameters menu appears on the screen. Set the desired parameters as described above. If the parameters are correct, proceed with the print operation by pressing the CONT (F2) function key.

	Y/N	FROM	TO
MEMORY CONFIGURATION:	Y		
I/O CONFIGURATION: CHANNEL, BASE	Y	1, 00	8, 15
LADDERS: ADDRESS NOP	Y Y	00001	65536
SF BOXES:	Y		
LOOPS:	Y	01	64
ANALOG ALARMS:	Y	001	128
SF PROGRAMS:	Y	0001	1023
SF SUBROUTINES	Y	0001	1023

Figure 8-3 Online Mode Print Options

This menu shows the default values for printing in a fully expanded system. Unless specified otherwise, all available categories will be printed. To prevent a category from being printed, change the "Y" (Yes) to an "N" (No).

Operation of the Print Function Key (continued)

	<p>You should type the starting and ending addresses for the category if you want only a particular section. Otherwise, everything in that category will be printed. The following paragraphs describe each of the categories in the menu.</p>
Memory Configuration	<p>This category prints the memory configuration as found in the P/C. (If you wish to print the memory configuration as it appears on a Program Disk, you must be in the Offline mode.)</p>
I/O Configuration	<p>This category prints the I/O configuration as obtained from the P/C. As shown in the chart, you may print all the channels and bases, or you may specify a particular channel and base. Note that this prints the I/O Configuration Chart rather than the I/O Module Definition Chart.</p>
Ladders	<p>This category prints the relay ladder logic program. You may print the entire program, or just those within certain limits as specified in the menu. You may also choose to include NOP (empty) rungs when the ladder logic is printed. However, unless a "Y" appears next to the "ADDRESS" entry, NOP rungs will not be printed. Also, remember that if the width of the page is set to 72 columns, both power rails will be omitted when the networks are printed.</p> <p>Once the items to be printed are selected on the menu, begin the print operation by pressing the EXECUTE (F2) function key. When all the items are printed, the final page of the printout will read "***PRINTING COMPLETE***".</p>
Printing while in the Offline Mode	<p>To begin the operation, press the PRINT function key. The system will respond with a menu for selecting the printer parameters. Configure the parameters as described in the preceding paragraphs on configuring print parameters. If the parameters are already set, proceed with the print operation by pressing the CONT (F2) function key. A menu for selecting what is to be printed is then displayed. See Figure 8-4.</p>

	Y/N	FROM	TO
SYNONYM CHARTS:			
I/O ELEMENTS	Y	0001	8192
CONTROL RELAYS	Y	0001	8192
OUTPUTS	Y		
MEMORY CONFIGURATION:	Y		
I/O CONFIGURATION:			
CHANNEL, BASE	Y	1, 00	8, 15
W/SYNONYMS	Y		
LADDERS:			
ADDRESS	Y	00001	65536
NOP	Y		
W/SYNONYMS	Y		
W/COMMENTS	Y		
LOOPS:	Y	01	64
ANALOG ALARMS:	Y	001	128
SF PROGRAMS:	Y	0001	1023
SF SUBROUTINES	Y	0001	1023

Figure 8-4 Offline Mode Print Options

The default values for the print options in a fully expanded system are shown in this menu. To prevent the printing of an entry in the menu, change the "Y" (Yes) to an "N" (No). The Return and arrow keys will allow you to step through the menu line by line. The following paragraphs explain each of the categories in the offline print menu.

Synonyms

This category allows you to print the synonyms assigned to an element of the network. The synonyms will be printed in tabular format rather than with the networks of ladder logic. You may print only the synonyms for the input and output variables, control relay synonyms only, output synonyms only, or any combination of the three. In order to save time in searching and printing, you should change the "From" and "To" columns to the minimum necessary.

Memory Configuration

This category prints the memory configuration as found on the Program Disk. (If you wish to print the memory configuration as it appears in the P/C, the VPU200 must be in the Online mode.)

Operation of the Print Function Key (continued)

- I/O Configuration** This category is similar to that which is available in the Online mode. The difference is that in the Offline mode you can also choose to print the synonyms assigned to each I/O point.
- Ladders** The final category is also similar to that which is available in the Online mode. The difference is that by being in the Offline mode, you may choose to print any comments and synonyms associated with the rungs. Remember that “Y” must appear for the “ADDRESS” entry or nothing will be printed and that if the column width of the page is set to 72 columns, neither power rail will be printed.
- Once the items to be printed are typed in the menu, begin the print operation by pressing the EXECUTE (F2) function key. When all the items are printed, the final page of the printout will read *****PRINTING COMPLETE*****.

8.5 Interrupting the Print Operation

While the screen or the categories are being printed, the function keys at the bottom of the screen will change to allow the printing operation to be interrupted. The function keys which become available are shown below:

ABORT	SUSPEND
F1	F2

FUNCTION KEYS

If you wish to halt printing, press the ABORT (F1) function key. This will halt the printing of the screen at the end of the line being transmitted. The page numbering will be reset to zero—which means that the next page printed will begin at one. Also, the screen showing the printer parameters will return to the screen.

Pressing the SUSPEND (F2) function key will also halt the printing of the screen at the end of the current line being transmitted. Note, however, that the printer may not stop immediately (after pressing either ABORT or SUSPEND) because of characters stored in the buffer memory of the printer. After the SUSPEND key is pressed, the following function keys will be displayed at the bottom of the screen:

ABORT	PAGE	RESUME	QUIT
F1	F2	F3	F4

FUNCTION KEYS

Interrupting the Print Operation (continued)

The ABORT (F1) function key performs as described above; the remaining function keys are described below:

F2 PAGE This function key is used when the printer paper needs to be changed. Pressing it will resume the printing until the end of the page is reached. When the end of the page is reached the printing will again halt and the four function keys will again be available.

F3 RESUME Pressing this function key will restart the printing operation.

F4 QUIT Pressing this will terminate the printing operation and advance the paper to the top of the next page.

If a printer error occurs while printing an error message will be displayed and only the ABORT key will be functional. If an error occurs other than with the printer, a VPU200 error message will appear and the print operation will abort.

NOTE: The time required for printing depends on the number of options selected, the size of L-memory, and the printing baud rate.

8.6 Printing Cross-References

Figure 8-5 shows the menu hierarchy for accessing the print cross-references function.

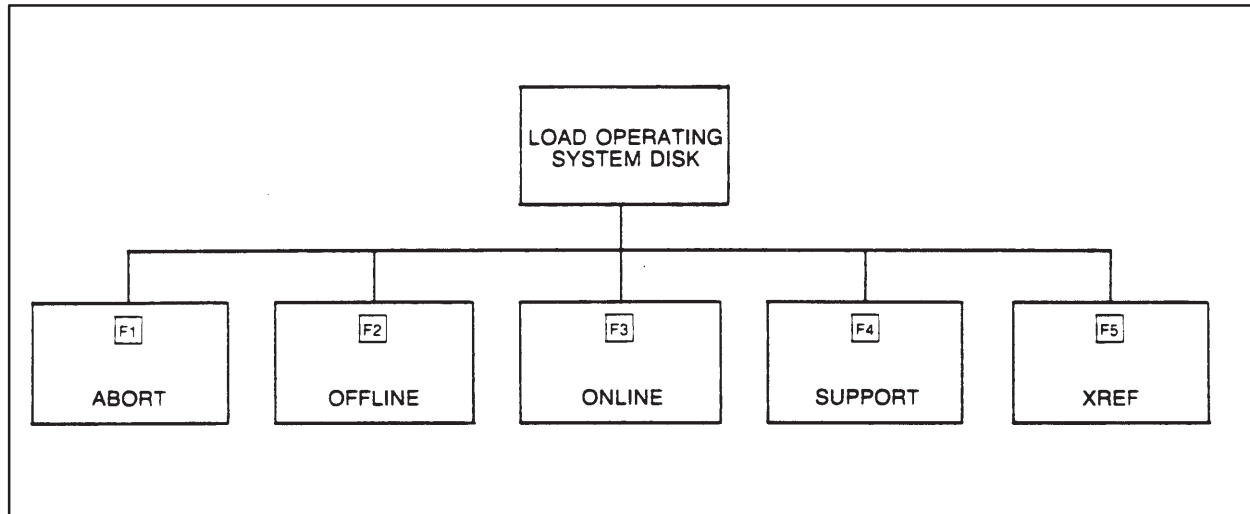

Figure 8-5 Accessing Print Cross-Reference

The Print Cross-Reference function provides the option of listing all I/O points (X,Y, WX, and WY), control relays (C), and user word memory (K and V) used in the ladder program. You may also request that synonyms be printed with the cross-reference listing. The memory locations are printed in numerical sequence in the order: X, Y, C, WX, WY, K, and V. Each type begins a new page. The specified maximum value determines search range. If you do not want a printout of all values, change the maximum values to those desired to save searching time.

After pressing F5 (XREF), the chart for selecting print parameters appears for selection of column width, baud rate, lines per page and entry of date. Upon completion of these items, press F2 to continue. A listing of cross-reference options then appears as shown in Figure 8-6.

Printing Cross-references (continued)

	<u>Y/N</u>	<u>FROM</u>	<u>TO</u>
CROSS REFERENCE:			
I/O ELEMENTS	Y	0001	8192
CONTROL RELAYS	Y	0001	8192
V MEMORY	Y	000001	228352
K MEMORY	Y	000001	226304
W/SYNONYMS	Y		
SELECT OPTIONS AND BOUNDARIES			
ABORT-F1 EXECUTE-F2			

Figure 8-6 Cross-Reference Options Select

Select what is to be printed by modifying the options listed in Figure 28. The values in this table default initially to the maximum size for each category. Once you select another boundary, it remains until either you change it or the VPU is re-initialized. The default for Y/N is Yes.

Appendix A

Error Messages

A.1	Types of Error Checking	A-2
-----	-------------------------------	-----

A.1 Types of Error Checking

When loops, analog alarms, and special function programs are entered, the VPU200 checks for errors. Table A-1 lists the error messages that are given when incorrect entries are made when programming loops and analog alarms. The messages tell you why the entry is incorrect. Special Functions Statements are also checked for illegal entries. Table A-2 gives you the types of error checks made. When the VPU encounters one of these error types at entry, the cursor returns to the field for correction of the error. The guidelines given in this table will enable you to determine the correction you should make; i.e., check variable type, range, etc., when an error is indicated.

Table A-1 Error Messages for Loop and Analog Alarm Entries

An input must be entered at this field
Low must be less than high
Values must be within PV range
Values must be within PV span
Values must be within PV span
Low-low must be less than or equal to low
High must be less than or equal to high-high
Yellow must be less than or equal to orange
Address is out of range
No memory has been configured for the address type selected

Table A-2 Error Checks for SF Statements

Only certain classes of responses (integer or real constant, integer, real, or discrete variable, yes or no, etc.) are allowed for certain parameters. (The allowable responses are given in the tables in the Loop, Analog Alarm, and Special Function Programming sections of this manual.)
A read-only variable (X, K, STW, WX, TCC, or LERR) may not be specified as the output of an SF Statement.
The variable name (one to four characters) must be a valid name as defined in the Loop, Analog Alarm, and Special Function Programming sections of this manual.
The variable must be within range for its type, based on the memory configuration for the P/C.
Certain variables may be accessed as integers only or as reals only. (This information is given in the Loop, Analog Alarm, and Special Function Programming sections of this manual.)

Customer Response

We would like to know what you think about our user manuals so that we can serve you better.
How would you rate the quality of our manuals?

	Excellent	Good	Fair	Poor
Accuracy	_____	_____	_____	_____
Organization	_____	_____	_____	_____
Clarity	_____	_____	_____	_____
Completeness	_____	_____	_____	_____
Graphics	_____	_____	_____	_____
Examples	_____	_____	_____	_____
Overall design	_____	_____	_____	_____
Size	_____	_____	_____	_____
Index	_____	_____	_____	_____

Would you be interested in giving us more detailed comments about our manuals?

Yes! Please send me a questionnaire.

No. Thanks anyway.

Your Name: _____

Title: _____

Telephone Number: (____) _____

Company Name: _____

Company Address: _____

Manual Name: SIMATIC VPU200/565 Programming Manual

Manual Assembly Number: 2597773-0006

Order Number: PPX:560/65-8102

Edition: Third

Date: 10/95

FOLD

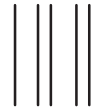

NO POSTAGE
NECESSARY
IF MAILED
IN THE
UNITED STATES

BUSINESS REPLY MAIL

FIRST CLASS PERMIT NO.3 JOHNSON CITY, TN

POSTAGE WILL BE PAID BY ADDRESSEE

ATTN: Technical Communications M/S 519
SIEMENS ENERGY & AUTOMATION INC.
3000 BILL GARLAND RD
P O BOX 1255
JOHNSON CITY TN 37605-1255

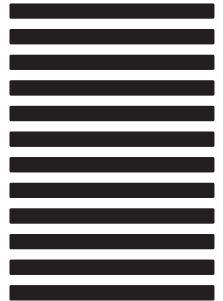

FOLD

SIMATIC is a trademark of Siemens AG.

VPU200, Series 505, and TIWAY are trademarks of Siemens Industrial Automation, Inc.