

SIMATIC NET

IM 180 PROFIBUS Interface Module

User Description

Date 20.10.1997

Order-Nr. 6ES7 180-0AA00-8BA0

SIEMENS

SIMATIC NET

IM 180

User Description

(PROFIBUS Interface Module
according to EN 50 170)

Version: 2.0
Date: 20.10.1997

Copyright

Unless permission has been expressly granted, passing on this document or copying it, or using and sharing its content, is not allowed. Offenders will be held liable. All rights reserved, in the event a patent is granted or a utility model or design is registered

Liability Exclusion

We have tested the contents of this document for agreement with the hard- and software described. Nevertheless, deviations can't be ruled out, and we are not guaranteeing complete agreement. The data in this document is, however, periodically checked, and required corrections are included in subsequent editions. We gratefully accept suggestions for improvement

Subject to technical changes

Content

1 PRODUCT FEATURES	5
2 MECHANICAL CONCEPT	6
2.1 Block Diagram	8
2.2 Function Description	9
3 INTERFACE DESCRIPTION	10
3.1 Hardware Interface	10
3.1.1 Connector Host Interface	10
3.1.2 PROFIBUS Interface	14
3.1.3 OTP Socket	17
3.1.4 Jumper Settings	17
3.2 Software Interface	18
3.2.1 Memory Segmentation of the DPRAM	18
3.2.2 Inputs / Outputs / Diagnosis of the Individual Slaves	19
3.2.3 Diagnostic Overview Channel	21
3.2.4 Communication Channel	27
3.2.5 Communication Sequence	28
3.2.6 Commands	28
3.2.7 Special Response Message	41
3.2.8 Unknown Call	41
3.3 Access Procedure	42
3.3.1 Diagnostic Overview Channel Data	42
3.3.2 Slave Diagnostic Data	42
3.3.3 Slave Input Data and Output Data	42
3.3.4 Setting Outputs for Long Consistency	49
3.3.5 Reading Inputs for Long Consistency or Buffering	49
4 PUTTING INTO OPERATION	50
5 USER PROGRAM	51
5.1 Transmission of Binary Data	51
5.2 Master Operation	51
5.3 Slave Operation	51
5.4 Master-Slave Operation	51

6 COM PROFIBUS	52
6.1 Settings	52
6.1.1 IM 180 Master	52
6.1.2 IM 180 Slave	53
6.1.3 IM 180 Master/Slave	53
6.1.4 Shared Slaves	53
6.2 Parameter File	53
7 IM181	54
7.1 General	54
7.2 Setting the Module Address in the PC/AT Address Space	54
7.2.1 DPRAM Area	54
7.2.2 I/O Address Area	55
7.2.3 Interrupt Channel	55
7.2.4 Jumper Settings	55
7.3 Memory Distribution	56
7.4 Register Description	56
7.4.1 Address Assignment	56
7.5 Pin Assignment for the Profibus Interface	58
8 BUS CONNECTION	59
9 ERROR NUMBER	60
9.1 Error Structure	60
9.2 Components	60
9.3 Important Error Numbers	61
10 GENERAL	62
10.1 Addresses	62
10.2 General Term Definitions	62

1 Product Features

The IM180 with the Firmware V3.0 makes customer-specific connection as master, slave or master/slave to a PROFIBUS DP network possible. The PROFIBUS interface is implemented by the ASPC2 STEP C or ASPC2 STEP D on the module.

The maximum possible baudrate for RS485 is 12 MBaud. It is to be noted that for more than 1.5 MBaud, different connectors (refer to chapter Bus Connection) are necessary.

For the inputs, outputs and diagnoses of all slaves, a memory of approx. 15.5 Kbyte DPRAM is available. For consistent data, a hardware control is available in addition, which can mutually lock the accesses to the DPRAM by host and master.

Using appropriate settings in COM PROFIBUS, the IM 180 can be used as a master, slave or master/slave. The individual functions will be described in later chapters.

The IM 180 can now perform master-master communication. COM PROFIBUS with online functionality is recommended for this.

This documentation describes firmware version V3.x of the IM 180.

Presently, these are the possible data lengths for each slave:

- 244 bytes parameter assignment data
- 244 bytes configuring data
- 244 bytes diagnostic data
- 244 bytes outputs without consistency
- 244 bytes outputs with consistency
- 244 bytes inputs with / without consistency

The operating temperature range for the components used is 0° ... +60° C.

2 Mechanical Concept

The mechanical scheme representation for the module is shown in Figure 1. In addition, the exact position of the fastening holes and the position of the plug connector is shown.

The module is connected to the host bus with a 64-pole plug connector (4*16 pins, standing)

- 4 x 16-pole
- MODU II
- 8 mm in height with holder
- 6 mm pin length

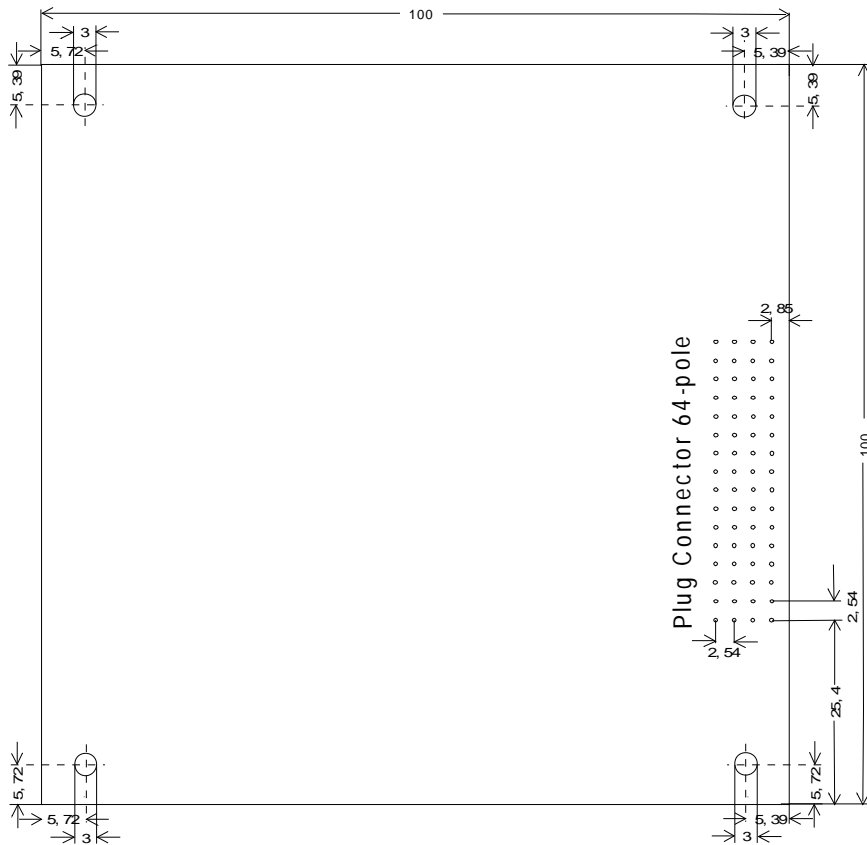

Figure 1: Mechanical scheme (dimensions in mm)

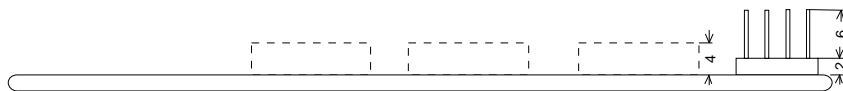

Figure 2: Mounting diagram, side view

As shown in figure 2, the maximum height of the modules is 4 mm. An exact positioning of the individual modules is not specified.

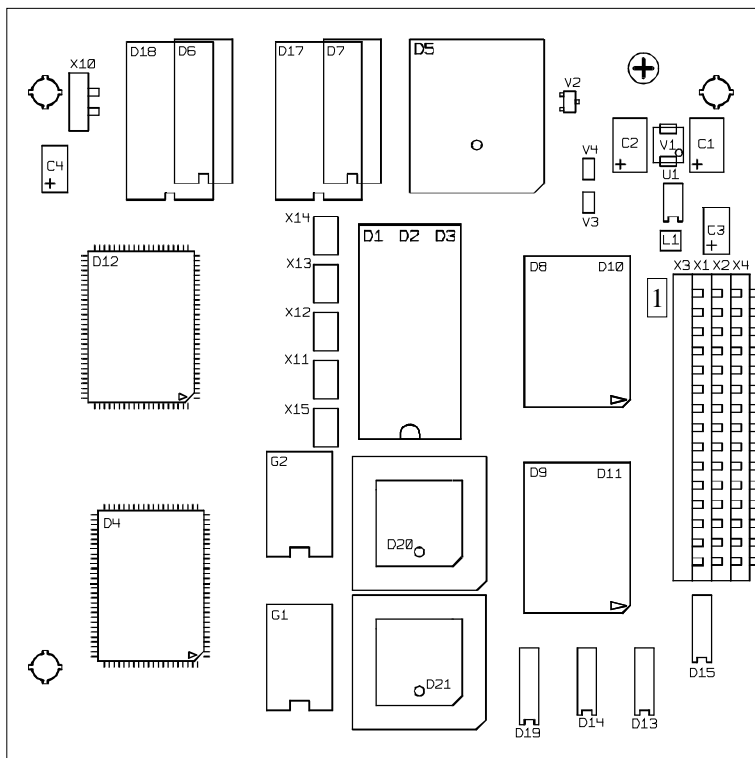

Figure 3: Plan View

Comment:

The fastening holes don't show in the figure „top view“. The circles shown there are positioning marks. The holes are only shown in the figure 'mechanical scheme'.

Moreover, in the plan view, the designation for the plug connectors is with the marking of Pin 1.

2.1 Block Diagram

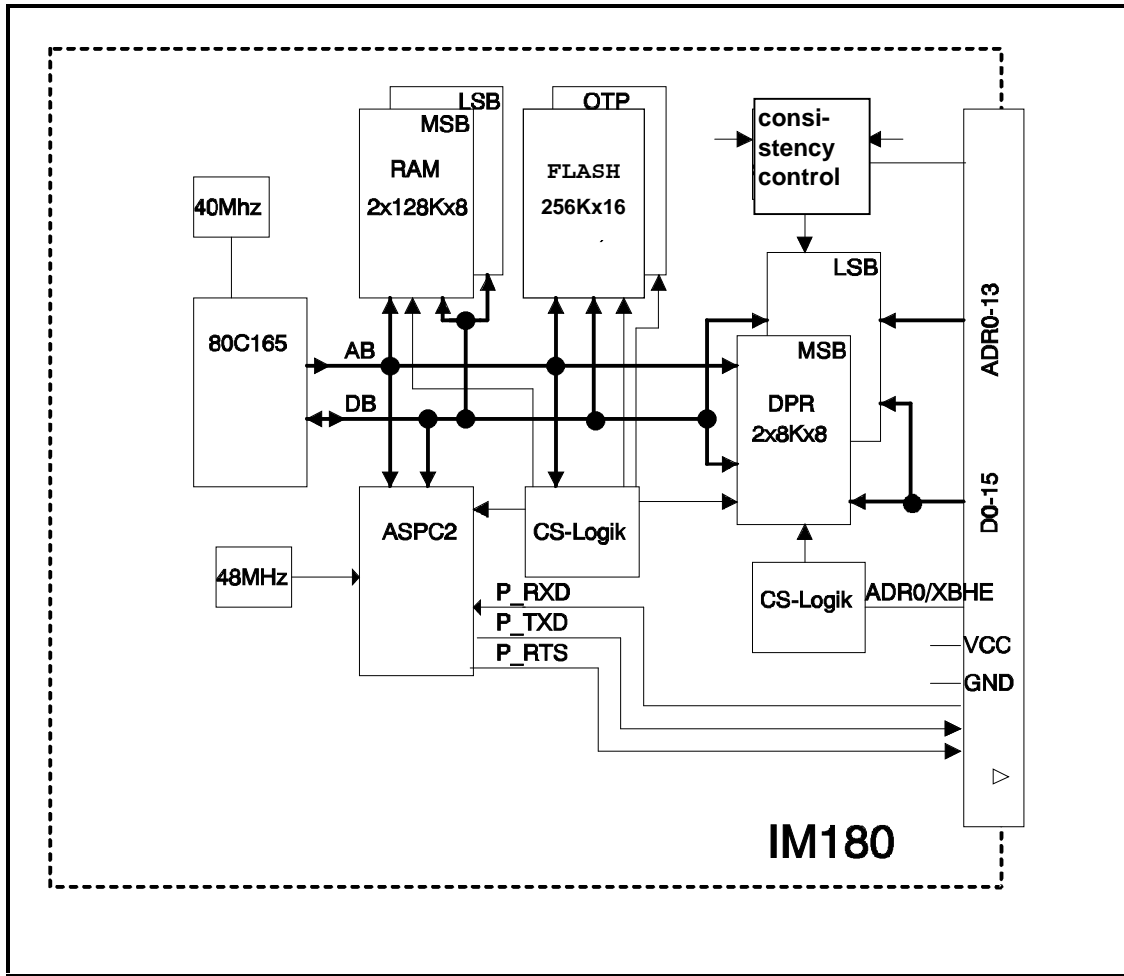

Figure 4: Block Diagram

2.2 Function Description

The following functionality is implemented on the module:

Design Engineering

- Module design rectangular (100mm x 100mm)
- Suitable for face-to-face mounting
- No display- and operator elements

Host Interface

- Pin connector (4 rows, 64-pole)
- 16 or 8 bit data bus can be connected
- Dual Port RAM (2x8Kx8)
- Consistence control
- Voltage supply for the module

Profibus Interface

- ASIC: ASPC2
- 12 MBaud max. transmission speed
- TTL signals on the host interface

Module Kernel

- CPU 80C165 / 40MHz
- 2 x 128Kx8 RAM
- 256K x 16 Flash EPROM as program- and parameter memory
- Generation of the programming voltage for the Flash EPROMS

3 Interface Description

3.1 Hardware Interface

3.1.1 Connector Host Interface

Features:

- Bus signals of the module for connection to the host
- Voltage supply for the module CPU
- Accesses possible byte by byte / word by word (decoding via ADR0/XBHE).
- TTL signals for triggering the level conversion (TTL <-> RS485)

Connector Pin Assignment:

Connector: Host Interface			
Type: Plug Connector (4 rows, 16-pole respectively, straight); pin height component-side 7mm			
X1 / Pin	Designation	Dir.	Function
1	ADR0	I	Address Bus Dual-Port-RAM
2	ADR4	I	Address Bus Dual-Port-RAM
3	ADR8	I	Address Bus Dual-Port-RAM
4	ADR12	I	Address Bus Dual-Port-RAM
5	D0	I/O	Data Line Dual-Port-RAM
6	D4	I/O	Data Line Dual-Port-RAM
7	D8	I/O	Data Line Dual-Port-RAM
8	D12	I/O	Data Line Dual-Port-RAM
9	GND		Ground 0 Volt
10	XBL	I	<u>reserved (0-active);</u> must absolutely be kept open
11	XRESET	I	<u>Reset-Signal (0-active);</u> Reset signal for the module; inactive(=1) if supply voltage is > 4.75V .
12	XTESTI	I-PU	<u>reserved (0-active);</u> must absolutely be kept open
13	XWH_CONS	I-PU	<u>Data consistency when writing for host(0-active);</u> Via this line, the host requests data-consistent write accesses to the DPR (refer to chapter Consistency Control).
14	VCC		Supply Voltage +5V
15	VCC		Supply Voltage +5V
16	VCC		Supply Voltage +5V
X2 / Pin	Designation	Dir.	Function
1	ADR1	I	Address Bus Dual-Port-RAM
2	ADR5	I	Address Bus Dual-Port-RAM
3	ADR9	I	Address Bus Dual-Port-RAM
4	ADR13	I	Address Bus Dual-Port-RAM
5	D1	I/O	Data Line Dual-Port-RAM
6	D5	I/O	Data Line Dual-Port-RAM
7	D9	I/O	Data Line Dual-Port-RAM
8	D13	I/O	Data Line Dual-Port-RAM
9	GND		Ground 0 Volt
10	RXD	I	<u>reserved (0-active);</u> must absolutely be kept open

11	XINTH	O	<u>Interrupt Output (0-active)</u> ; is triggered by a write access of the CPU to the semaphore register (refer to chapter DPRAM Memory). A read access by the host to the same DPR cell deletes the interrupt.
12	XTESTO	I/O-PU	<u>Impuls-Signal (0-active)</u> ; Signal with low-Impuls comes from the CPU
13	XHKAK	O	<u>Host-Consistency-Acknowledge (0-active)</u> ; Enable of data-consistent accesses on the host-side (reply of the CPU-side to the request; refer to chapter Consistency Control).
14	XBHEH	I	<u>Byte-High-Enable (0-active)</u> ; together with the address bus ADR0, signals the type of access (16/8-bit; refer to table 2).
15	XRDH	I	<u>RD-Signal of the host interface (0-active)</u> ; signals read accesses.
16	XWRH	I	<u>WR-Signal of the host interface (0-active)</u> ; signals write accesses.
X3 / Pin	Designation	Dir.	Function
1	ADR2	I	Address Bus Dual-Port-RAM
2	ADR6	I	Address Bus Dual-Port-RAM
3	ADR10	I	Address Bus Dual-Port-RAM
4	P3_13	I-PU	<u>reserved</u> ; must absolutely be kept open
5	D2	I/O	Data Line Dual-Port-RAM
6	D6	I/O	Data Line Dual-Port-RAM
7	D10	I/O	Data Line Dual-Port-RAM
8	D14	I/O	Data Line Dual-Port-RAM
9	VCC		Supply Voltage +5V
10	TXD	O	<u>reserved (1-active)</u> ; must absolutely be kept open
11	A_CONS	O	<u>ASPC2-Consistency (1-active)</u> ; signals a conflict. From this time on, the ASPC2 no longer performs communication on the PROFIBUS. The CPU is also disabled.(See chapter Consistency Control.)
12	RDYH	O	<u>Ready-Signal (1-active)</u> ; Extensioin of the running bus cycle (=0)
13	XRH_CONS	I-PU	<u>Data consistency when reading for host (0-active)</u> ; Via this line, the host requests data-consistent write accesses to the DPR (refer to chapter "Consistency Control").
14	GND		Ground 0 Volt
15	GND		Ground 0 Volt
16	GND		Ground 0 Volt
X4 / Pin	Designation	Dir.	Function (new pin row)
1	ADR3	I	Address Bus Dual-Port-RAM
2	ADR7	I	Address Bus Dual-Port-RAM
3	ADR11	I	Address Bus Dual-Port-RAM
4	XCSHOST	I	<u>CS-Signal DPR (0-active)</u> ; CS-Signal of the HOST-side for accessing the DPR.
5	D3	I/O	Data Line Dual-Port-RAM
6	D7	I/O	Data Line Dual-Port-RAM
7	D11	I/O	Data Line Dual-Port-RAM
8	D15	I/O	Data Line Dual-Port-RAM
9	VCC		Supply Voltage +5V
10	XOperating System	I-PU	<u>Boot from OTP (0-active)</u> ; If log.0, booting from the OTP.

11	P2_9	I-PU	<u>reserved;</u> must absolutely be kept open
12	P2_10	I-PU	<u>reserved;</u> must absolutely be kept open
13	P3_15	I-PU	<u>reserved;</u> must absolutely be kept open
14	P_TXD	O	<u>Profibus Send Data;</u> Send data of the ASPC/2 (TTL-Signal)
15	P_RXD	I	<u>Profibus Receive Data;</u> Receive data of the ASPC/2 (TTL-Signal)
16	P_RTS	O	<u>Profibus-Request to Send;</u> Control of send direction (TTL-Signal)

Table 1: Connector

Legend:

X<name>:	low-active signal
I:	input at module
O:	output from module
I/O:	bidirectional signal
PU:	pull-up resistor

3.1.1.1 Address Decoding

3.1.1.1.1 Decoding of the 16/8 Bit Accesses by means of A0 and XBHE:

XBHE	ADR0	Type of access
0	0	16-Bit Transfer (LSB + MSB)
0	1	8-Bit Transfer (MSB)
1	0	8-Bit Transfer (LSB)
1	1	invalid/impermissible combination

Table 2: Decoding

3.1.1.1.2 Single 8 Bit Data Bus:

- o LSB and MSB of the data bus bridged at host connector
- o Connect inverted address bus (ADR0) to pin XBHE

3.1.1.2 DPRAM Memory

Company: Fujitsu
 Memory Type: MB 8441-55
 Memory Size: 2 x 8k x 8 (16KByte)

DPRAM	CPU-Side	Host-Side
Address Range		relative to XCShOST signal: 0000H - 3FFFFH
Data Bus Width	16-Bit	8/16-Bit Decoding of the access with XBHE and ADR0 of the host interface
Semaphore Register	04.3FFCH ... 04.3FFFH	XCShOST + (3FFCH...3FFFH)
Write access at leads to:	04.3FFCH + 04.3FFDH Interrupt on host side	XCShOST + (3FFEh...3FFFh) Interrupt on the CPU side (in the case of 8 bit accesses, consecutive addresses have to be accessed respectively)
Read access at acknowledgement of the interrupt and enable next interrupt	04.3FFEh + 04.3FFFh acknowledgement of the interrupt from host	XCShOST + (3FFCh ...3FFDh) Acknowledgement of the interrupt from the CPU (in the case of 8 bit accesses, each addresses has to be read).
Conflict control (if there is a "simultaneous" access to the same word from both sides, one side is stopped)	XBUSY-Signal 0: Access is extended	RDY-Signal 0: access is extended
Consistency of the DPR	Dependent on the width of the data bus on the host-side: for 16-Bit data bus: 16-Bit for 8-Bit data bus: 8-Bit	

Table 3: DPRAM

3.1.1.3 Voltage Supply

Nominal voltage	5V
Low limit static	4.75V (-5%)
High limit static	5.25V (+5%)
Current input	ca. 250 mA
Residual ripple	100mV _{SS}

3.1.1.4 Reset Signal

The length of the reset signal has to be at least 44µs.

3.1.2 PROFIBUS Interface

The signals of the ASIC ASPC2 RxD, TxD and RTS are brought out via the host connector. They usually are applied to a socket where the Profibus line with the connectors is connected (refer to chapter wiring example).

As shown by the circuiting example, sending and receiving signals are connected via the RS 485 driver block. This connection is required since the ASPC2 must read back its sending data (i.e., otherwise, it will suspect hardware errors and halt).

The firmware cannot start up unless the ASIC signals are circuited appropriately.

3.1.2.1 Pin Assignment of the Profibus Connection

Data is transmitted in the operating mode RS485 (RS485 physics).

The PROFIBUS interface is designed as 9-pole SUB-D socket with the following pin assignment:

Pin 1 - not connected

Pin 2 - not connected

Pin 3 - B - Line

Pin 4 - Request to Send (RTS)

Pin 5 - Ground 5V (**M5**)

Pin 6 - Potential 5V (**potential free P5**)

Pin 7 - not connected

Pin 8 - A - Line

Pin 9 - not connected

The line shield is to be connected with the connector casing.

In DIN 19245, the not connected pins are used optionally; if the user uses them, they should correspond to this description.

Attention:

The designations **A** and **B** of the lines on the socket correspond to the designations in the RS485 standard, and not to the pin designation of driver ICs.

The line length from the driver to the socket is to be kept as short as possible.

When using the higher baudrates from 3 to 12 MBaud, new connectors have to be used. These connectors compensate line influences for all possible line combinations (refer to chapter Bus Connection)

3.1.2.2 Send Timing

No.	Parameter	MIN	MAX	Unit
Clock 48 MHz :				
1	RTS ↑ to TxD Setup Time	5T		
2	RTS ↓ to TxD Hold Token	4T		

Table 4: RTS- Timing

T = clock cycle (48MHz)

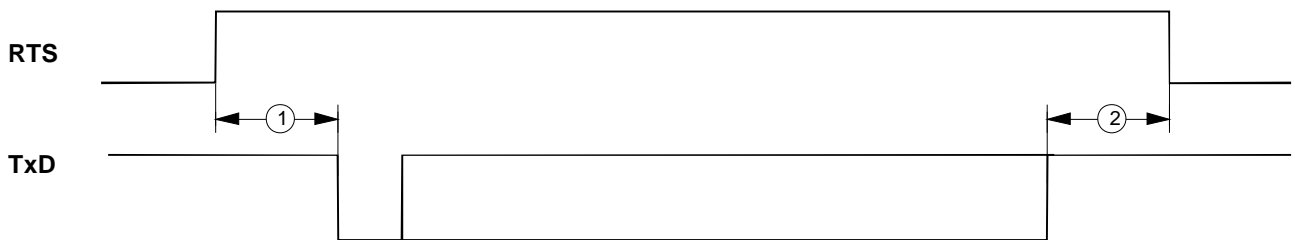

3.1.2.3 DC-Spezifikation

Signal:	Parameter:	MIN:	MAX:
RTS,TXD	Output current, 0 level	8 mA	
	Output current, 1 level	8 mA	
	Output current, 0 level		0,5 V
	Output current, 1 level	VS - 0,8 V	
RXD	Input current, 0 level		0,8 V
	Input current, 01level	2,0 V	

Table 5: DC-Specification

Information on the TTL signals of the ASPC2

3.1.2.4 AC-Specification

Signal:	Driver type:	Performance:	Cap. Load:
RTS,TXD	not tristate	8 mA	50 pF

Table 6: AC-Specification

Information on the TTL signals of the ASPC2

3.1.2.5 Wiring Example

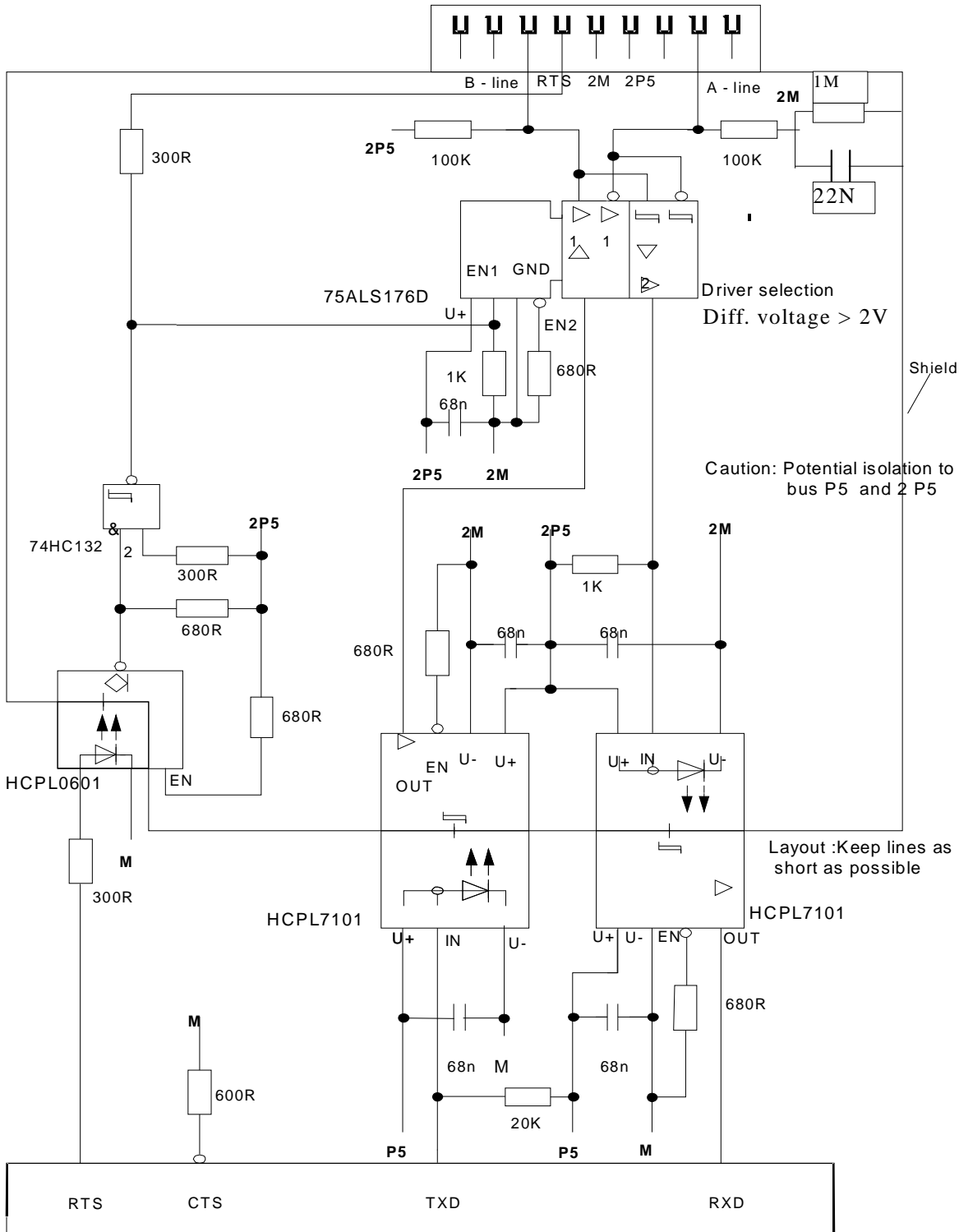

3.1.3 OTP Socket

Model: PLCC32
 Size: max. 512K x 8
 Access time: 150ns

You can plug in OTP as well as Flash-EPROMs in this socket (refer to Chapter, Figure 3: Plan View D5).

The following data can be transmitted:

3.1.3.1 Entire Firmware

To load the entire firmware into the IM180, the following sequence is necessary:

- switch off the IM180
- insert Jumper X15 (refer to Chapter, Figure 2, Plan View)
- insert EPROM with 'entire firmware' in slot
- switch on device
- let operate for about 1 minute
- switch off device
- remove Jumper X15 and EPROM
- switch on device
- during power-up, the DEFAULT setting is loaded and an error message is indicated
- perform reset
- device is ready for operation

3.1.3.2 Firmware Main Part

To load the Main Part of the firmware into the IM180, the following sequence is necessary:

- switch off the IM180
- insert EPROM with 'Firmware Main Part' in slot
- switch on device

The IM180 checks during power-up whether a firmware is in the slot and whether a recent version is available. The new version will be loaded accordingly. The EPROM need not be removed.

3.1.3.3 Parameter Binary File

To load the parameter binary file via the slot into the IM180, the following sequence is necessary:

- switch off the IM180
- insert EPROM with 'parameter binary file' in slot
- switch on device
- perform software reset with the request parameter from the OTP slot.

3.1.4 Jumper Settings

Designation:	X15 - Boot from OTP (XBESY)
Type:	2-pole terminal strip
open	normal state
inserted	Boot from OTP socket

Table 7: Jumper settings

3.2 Software Interface

3.2.1 Memory Segmentation of the DPRAM

The figure below shows the segmentation of the 16 KByte Dual Ported RAM:

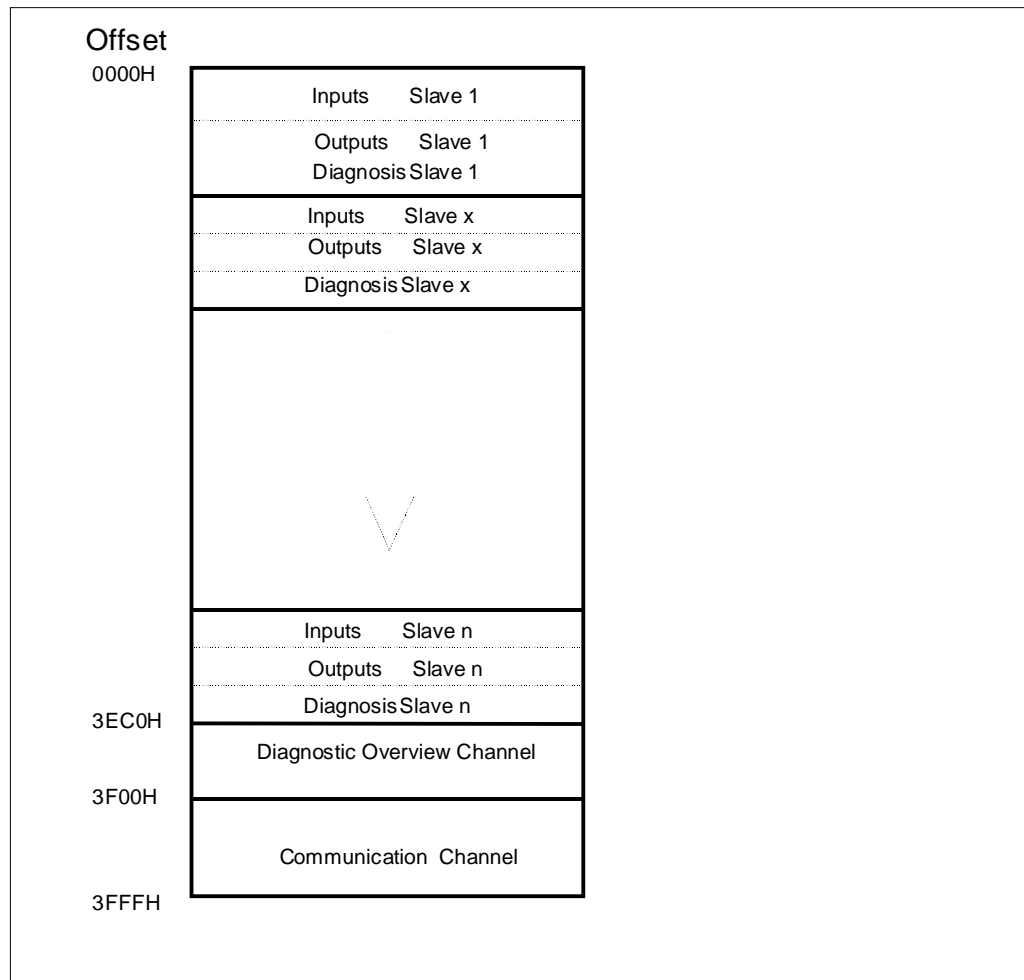

Figure 5: DPRAM

x ... slave address of the next available slave

n ... slave address of the last available slave (maximum value = 123)

3.2.2 Inputs / Outputs / Diagnosis of the Individual Slaves

For this data, 16064 bytes are available at the 16 KBytes DPRAM. The distribution depends on the lengths of the inputs/outputs and the diagnostic data of the available slaves (that is, only as many bytes per slave are entered as there are slaves actually present).

The start addresses for the inputs/outputs and the diagnoses always start at even addresses.

Via the diagnostic length byte, the present diagnostic length can be determined.

The diagnostic counter byte is needed to check the diagnostic data for consistency.

With each new entry of the IM180, this counter is incremented so that, when reading out the diagnosis from the host, the diagnostic count value has to match before and after the access.

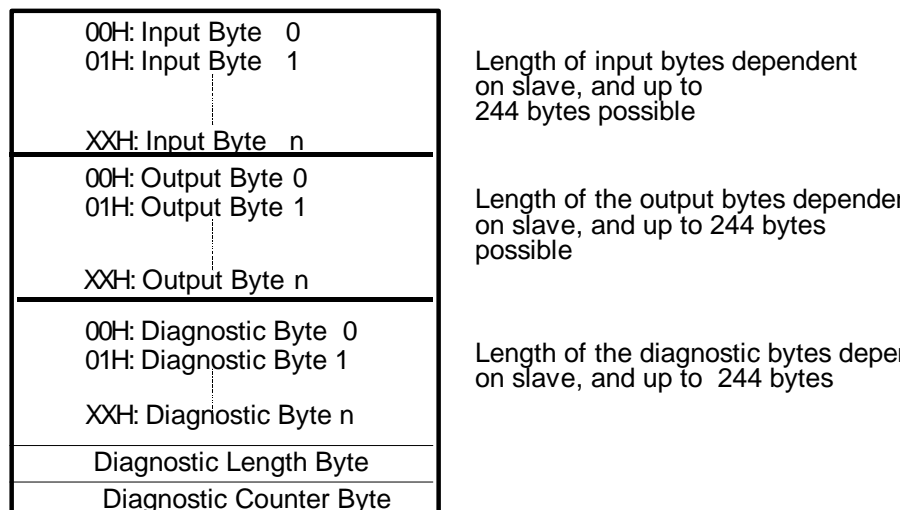

Figure 6: Segmentation

The information about slaves, addresses and area lengths which the host needs are transferred to the host at the request 'transfer data structure'; that is,

Only the data about the available slaves is in the DP-RAM.

3.2.2.1.1 Diagnosis

The input is made according to DIN Draft 19245 Part 3. According to the standard, the diagnosis may contain 244 bytes information maximum. The first 6 bytes are permanently assigned, the remaining bytes are user-specific (described functions are valid if the value is "1").

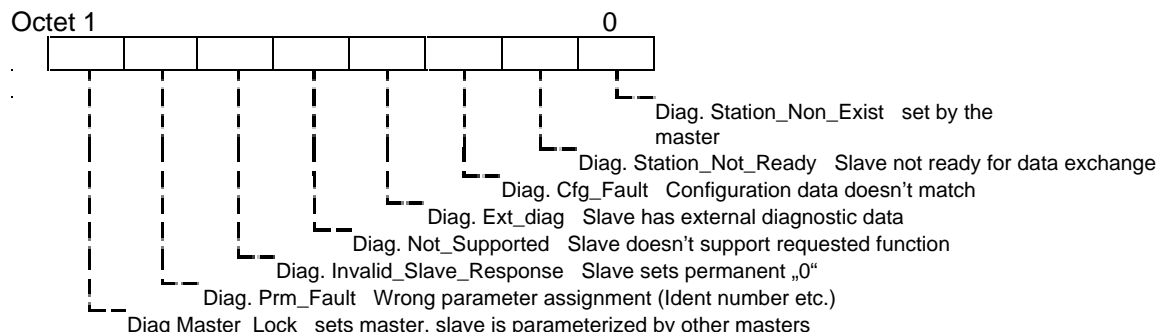

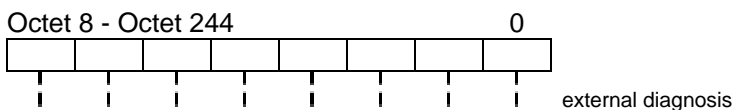
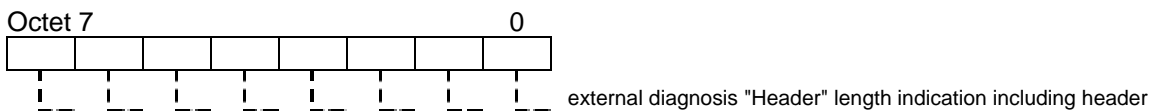
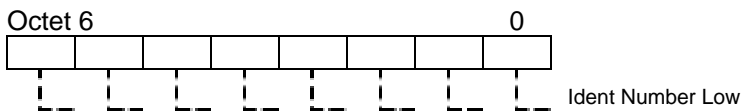
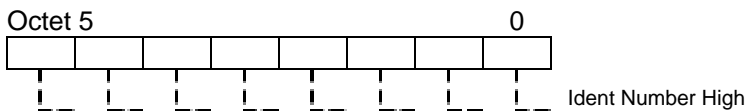
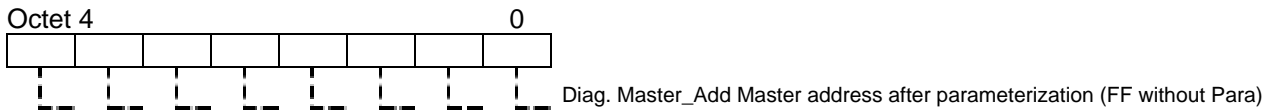
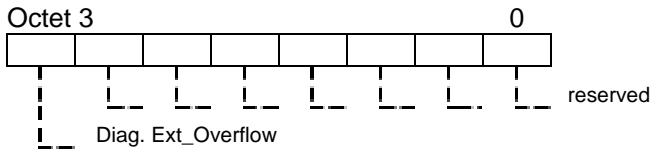
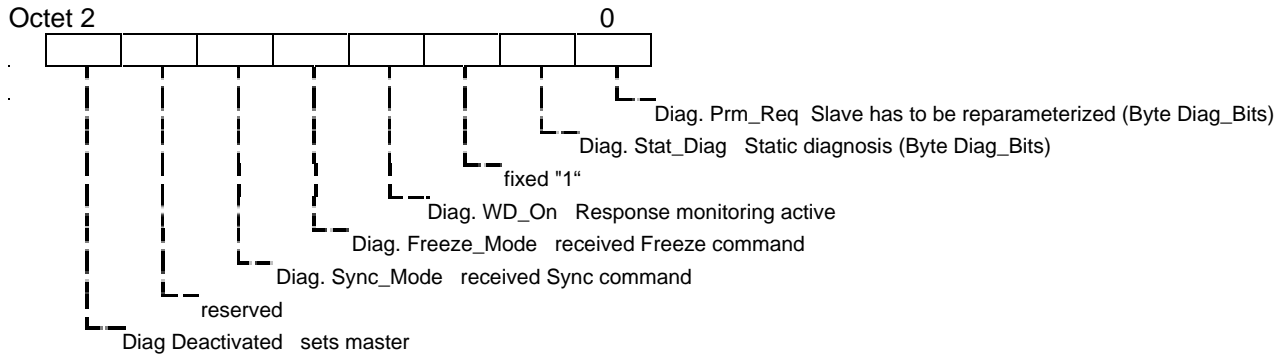

The description of the external diagnosis is provided in the descriptions of the individual slaves.

3.2.3 Diagnostic Overview Channel

0x3ECO	System Diagnostic
0x3EDO	Master State
0x3EEO	Data-Transfer-List
0x3EFO	System Error Channel
0x3EFA	Slave State
0x3EFB	Slave Info
0x3EFC	State
0x3EFD	reserved
0x3EFE	Info
0x3EFF	reserved

Figure 7: Diagnostic Overview

The diagnostic overview channel provides additional information about the individual slaves, the master and, if there are system errors, a detailed error localization.

3.2.3.1 Detailed Structure

The words are available in the overview diagnosis in the INTEL format.

Area	Type	Meaning	Explanation
System Diagnosis	bit	Slave-Nr. 0 _D	Bit Nr. X = 0 _B : Slave Nr. X has signalled no diagnoses
	bit	Slave-Nr. 1 _D	
	bit	Slave-Nr. 2 _D	Bit Nr. X = 1 _B : Slave Nr. X has signalled diagnoses
	:	:	
	bit	Slave-Nr. 122 _D	
	bit	Slave-Nr. 123 _D	
	bit[4 _D]	<i>reserved</i>	-
Master Status	byte	USIF_State	Master-Status: STOP, CLEAR, OPERATE
	byte	Ident_Number_high	Hardware Ident Number High
	byte	Ident_Number_low	Hardware Ident Number Low
	byte	MASTER_HW_Version	AMPRO-DPM Hardware version
	byte	MASTER_FW_Version	AMPRO-DPM Firmware version
	byte	USER_HW_Version	USER's Hardware version
	byte	USER_FW_Version	USER's Firmware version
	byte[9 _D]	<i>reserved</i>	-
Data Transfer List	bit	Slave-Nr. 0 _D	Bit Nr. X = 0 _B : Slave Nr. X is not in the dataexchange mode
	bit	Slave-Nr. 1 _D	
	bit	Slave-Nr. 2 _D	Bit Nr. X = 1 _B : Slave Nr. X is in dataexchange mode
	:	:	
	bit	Slave-Nr. 122 _D	
	bit	Slave-Nr. 123 _D	
	bit[4 _D]	<i>reserved</i>	-
System Error Channel	word	Component	Module name of Firmware
	word	Supcomponent	Module's sup-component
	word	Status	Status value
	word	Number	Error number
	word	Detail	Detail
Info	byte	Slave State	State of the IM180 as slave
	byte	Slave Info	Info of the IM180 as slave
	byte	State	State of the IM180
	byte	reserviert	
	byte	Info	Info of the IM180
	byte	reserviert	

Table 8: Diagnosis

3.2.3.2 System Diagnosis

The area "System Diagnosis" is a bit field; a bit is assigned to each slave station. In the scheme below, the slave station numbers associated with each bit are listed in the table:

Bit	15	14	13	12	11	10	9	8	7	6	5	4	3	2	1	0
Word																
0	15	14	13	12	11	10	9	8	7	6	5	4	3	2	1	0
1	31	30	29	28	27	26	25	24	23	22	21	20	19	18	17	16
:	:	:	:	:	:	:	:	:	:	:	:	:	:	:	:	:
:	:	:	:	:	:	:	:	:	:	:	:	:	:	:	:	:
7	111	110	109	108	107	106	105	104	103	102	101	100	99	98	97	96
8	-	-	-	-	123	122	121	120	119	118	117	116	115	114	113	112

Table 9: System diagnosis bits

A bit in the area "System Diagnosis" is set for the first time when the associated slave leaves the DEACT mode. The bit is reset after the slave changed to the DATA mode. During processing, the bit will always be set when the slave signals diagnoses (state not I DATA and not like DEACT); that is, a single diagnostic message during the data cycle (state transition DATA -> DIAG2 -> DATA) also causes the bit to be set.

Information about Slave State

Slave State	meaning
DEACT	Slave is not addressed
DATA	Master make dataexchange with the slave
DIAG2	Slave have diagnostic or state information

Table 10: Slave state

3.2.3.3 Master_Status

3.2.3.3.1 USIF State

This variable specifies the current master status. It is set by the master software. This byte is only written when the master software is activated (i.e., the IM 180 is activated as master by COM PROFIBUS).

USIF State	Hex Value	Explanation
OFFLINE	0x00	Token and slave handling of the master is disabled.
STOP	0x40	Slave handling of the master is disabled.
CLEAR	0x80	The slaves receive zero data in the output direction.
OPERATE	0xC0	The slaves are in user data operation.

Table 11: USIF-State-Byte

3.2.3.3.2 Identnumber

The ident number of the IM 180 is located here.

3.2.3.3.3 Masterversion

The hardware identifier contains the required hardware version of the IM 180. The firmware version contains the version of the master software.

3.2.3.3.4 Userversion

The hardware identifier contains the required hardware version of the IM 180.
 The firmware version contains the version of the total software.

3.2.3.4 Data Transfer List

The area "Data_Transfer_List" is a bit field; a bit is assigned to each slave station. In the scheme below, the slave station numbers associated with each bit are listed in the table:

Bit	15	14	13	12	11	10	9	8	7	6	5	4	3	2	1	0
Word																
0	15	14	13	12	11	10	9	8	7	6	5	4	3	2	1	0
1	31	30	29	28	27	26	25	24	23	22	21	20	19	18	17	16
:	:	:	:	:	:	:	:	:	:	:	:	:	:	:	:	:
:	:	:	:	:	:	:	:	:	:	:	:	:	:	:	:	:
7	111	110	109	108	107	106	105	104	103	102	101	100	99	98	97	96
8	-	-	-	-	123	122	121	120	119	118	117	116	115	114	113	112

Table 13: Data Transfer Bits

A bit in the area "Data Transfer List" is always set if the associated slave has reached or retained the DATA mode at least once during the approx. last three data cycles.

3.2.3.5 Analysis

With the combination System Diagnostic bit and Data Transfer List bit per slave, a response corresponding to the decision table below is possible:

System Diagnosis:	Data Transfer List	Slave State
0	0	Slave not in processing cycle
0	1	Slave without fault and can be addressed
1	0	Slave not on bus or can't be addressed
1	1	Slave with fault and can be addressed

Table 13: Analysis

You have to check that the Data Transfer List is only all 3 cycle up to date.

3.2.3.6 System Error Channel

If an internal IM 180 error should occur, "System Error Channel" contains additional information for localization of the failure.

Since an error can occur at any time, the first word location must be polled continuously or appropriate settings must be made in the "Softwarereset" command to generate a message containing the communication channel when a system error occurs.

The IM 180 also offers the capability of loading the DEFAULT settings when a system error causes a standstill. This is accomplished by writing 0x7F to the command location in the communication channel. A hardware reset must always be performed afterward.

See chapter Error number for a detailed description of the error numbers.

3.2.3.7 Slave State

When the slave function of the IM 180 is activated by COM PROFIBUS, the "slavestatus" byte indicates the slave states shown below.

Slavestatus	Hex Value	Explanation
WAIT_PRM	0x00	Slave is waiting for the parameterization telegram.
WAIT_CNF	0x01	Slave is waiting for the configuration telegram.
DATA_EX	0x02	Slave is performing data communication.

Table 14: Slave State Byte

3.2.3.8 Slave Info

When the slave function of the IM 180 is activated by COM PROFIBUS, the "slaveinfo" byte indicates the information on the slave shown below. This byte specifies whether the master is in CLEAR or OPERATE status.

Slave info	Hex Value	Explanation
UNCLEAR	0x00	The slave is performing user data communication.
CLEAR	0x01	The slave is in CLEAR mode.

Table 15: Slave Info byte

3.2.3.9 Status

The status byte specifies the current status of the total software. The primary purpose of this byte is to handle coordination during startup. When this byte contains the status value for STOP, communication with the IM 180 may be started.

Status	Hex Value	Explanation
OFFLINE	0x00	IM 180 can no longer be manipulated (i.e., HW reset is the only alternative).
STOP	0x40	IM 180 as master is in token handling. IM 180 as slave only sends RS to master.
CLEAR	0x80	IM 180 as master sends clear telegrams to slaves. IM 180 as slave is active.
OPERATE	0xC0	IM 180 as master sends user data telegrams to slaves. IM 180 as slave is active.

Table 16: Status byte

3.2.3.10 Info

The info byte specifies a current status of the IM 180. This byte is a direct copy of the LED states of the IM 308C. For a detailed description, see the documentation of COM PROFIBUS.

Bit	7	6	5	4	3	2	1	0
Signal	RN2	RN1	OF2	OF1	BF2	BF1	IF2	IF1

RN1,RN2 Information on the RUN LED
 OF1,OF2 Information on the OF LED
 BF1,BF2 Information on the BF LED

IF1,IF2 Information on the IF LED

The table below shows the meaning of the LED values which can occur for any LED.

Identifier bits	00	01	11	10
Function	Off	On	Flashing	Not available

3.2.3.10.1 BF LED

BF LED	Meaning
Off	IM 180 master is performing data communication with all configured slaves.
On	Bus error (i.e., short circuit on the bus, differing Baud rates, HSA less than master address, faulty RS 485 circuiting, and so on)
Flashing	Data communication is not being performed with at least one of the configured slaves.

3.2.3.10.2 Other LEDs

RN	OF	IF	Meaning
Off	On	Off	IM 180 is in OFFLINE mode. See chap. 3.2.3.9.
Off	Flashing	Off	IM 180 is in STOP mode. See chap. 3.2.3.9.
Flashing	Off	Off	IM 180 is in CLEAR mode. See chap. 3.2.3.9.
On	Off	Off	IM 180 is in OPERATE mode. See chap. 3.2.3.9.
Off	Off	On	System error. See chap. 3.2.3.6.
On	Off	On	Master system exported to IM 180 by COM PROFIBUS
Off	On	On	IM 180 waiting for activation of transferred master system
Flashing	Flashing	Off	Main part of firmware being loaded to IM 180
On	On	Off	Transfer of main part of firmware concluded without errors
On	On	Flashing	Transfer of main part of firmware concluded with errors

3.2.4 Communication Channel

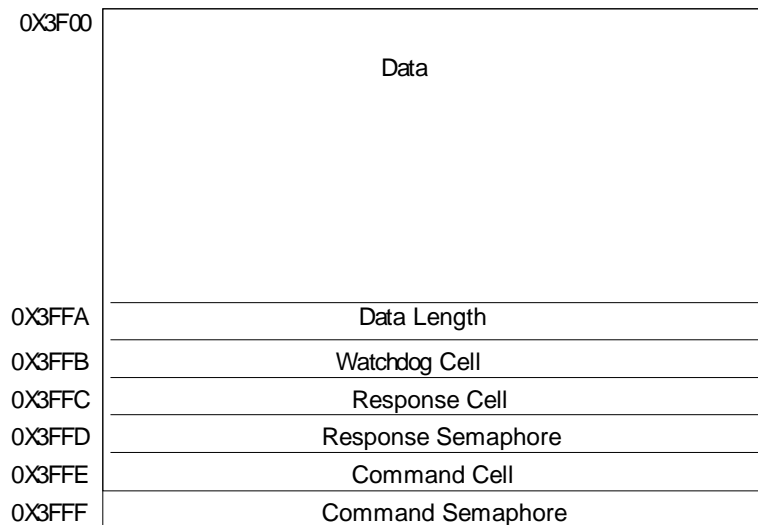

Figure 8: Communication

- Data:** Information necessary for the command or the response (250 bytes maximum).
- Data Length:** Length of the information in bytes.
- Watchdog Cell:** Monitoring between IM180 and host when using watchdog setting.
- Command Cell:** Entry of the request with the corresponding number by the host.
At the same time, set command semaphore for coordination.
A command is only to be entered if the command semaphore is zero.
- Command-Semaphore:** If this identification is zero, the previous command has been processed and a new request can be made.
If the semaphore is not zero, the previous command hasn't been processed yet.
After the request has been executed, the IM180 will clear this semaphore.
- Response Cell:** Here, after the request has been completed, the response is stored as command code repetition by setting the response semaphore.
When the host has read out the answer, the semaphore has to be deleted so that the IM180 is provided with the information that the response cell can be written to again.
- Response-Semaphore:** If this identification is set to zero, the last response has been processed, and the IM180 can enter the next answer.
If the semaphore is not zero, the host has not fetched the previous reply, and no new response can be entered.

3.2.5 Communication Sequence

Before each request, a check is to be made whether the command semaphore (that is, the last request by the IM180 has been processed) and the response semaphore (that is, the host has fetched the last request) is 0 (the check may be omitted if it is ensured that each response to a request is being fetched before a new command is transmitted). If this is the case, a command may be written into the command cell and a value unequal to 0 into the command semaphore (both cells are always to be written to, refer to description for DPRAM). As indication that the response has been processed, the response semaphore is to be deleted.

3.2.6 Commands

Host and IM180 communicate via command- and response cell. The host may transfer a command which the IM180 will evaluate and process further via interrupt. The host may wait for the resulting reply by polling the response cell, or, when using the interrupt signal from the DPRAM, react to the exact arrival of the message or check the cell at a later time. This makes it possible for the host to perform other work until the arrival of the command completion, since the runtime differs quite a bit depending on the command.

Below, the commands are listed:

3.2.6.1 Software Reset of the IM180

Command:	perform software reset for the IM180
Command Byte:	01H
Command Length:	1
Command Data:	<ul style="list-style-type: none"> - identification for start with current or default parameter-set - identification for start of the IM180 with STOP/CLEAR or RUN - identification whether a system error generates an interrupt

Reset Byte:

Bit 7	Bit 6	Possible Settings
0	0	OFFLINE-Mode
0	1	STOP Mode
1	0	CLEAR Mode
1	1	OPERATE Mode

Table 17: Resetbyte during start up phase

Bit 5	Bit 4	Possible Settings
0	0	Momentary parameters remain
0	1	Load default parameter
1	0	Parameter of the OTP slot
1	1	reserved

Table 18: Resetbyte parameters

Bit 3,2,1 as required

Bit 0	Possible Settings
0	no meaning
1	System error at IM180 generates a message (that is, a message with the value 7FH)

Table 19: Resetbyte system error

The reset byte can be used to perform various activities.

1) Setting the master status which the IM 180 is to assume after the reset

Caution: OFFLINE status can only be exited with a hardware reset. No commands can be sent to the IM 180.

2) Setting the parameter source to be taken during IM 180 startup

- Keep current parameter record
- Load default parameter record
- Load parameter record from OTP slot

3) Setting the reaction to be generated by a system error

When a system error occurs, an entry is usually made in the diagnostic overview channel and the master is stopped. This means that these memory locations are polled continuously. Activation of this identifier will also give you a response telegram with the system error data. This makes it easy to identify a system error.

Response: Command repetition after request has been processed

Response Length: 2

Response Data: refer to table below:

Response Value	Explanation
0x0000	Command carried out correctly
0x0100	Command semaphore is not set

3.2.6.2 Synchronization Command

Command: Synchronization command between IM180 and host

Command Byte: 02H

Command Data: as required

Response: Command repetition if the IM180 is available

Response Length: 2

Response Data: refer to table below:

Response Value	Explanation
0x0000	Command carried out correctly
0x0100	Command semaphore is not set

3.2.6.3 Transfer Data Structure

Command: Transfer of data information about the data structure which is necessary for the slave data access.

Command Byte: 03H at request start

83H for follower block requests

Command Data: as required

Response: In addition to command repetition, the highest bit is set as identifier that further blocks are still coming (Value = 83H).

The last block is transferred without setting the highest bit (Value = 03),

and the last response is signalled.

- Response Length:** Length of the data in the data area, or 2 if there is an error.
- Response Data:** Data in blocks of 250 bytes maximum for the specific data structure
- information, which slaves are present
 - information about the input- and output data (without / short / long consistency)
 - information about the input-/output- or diagnostic data length
 - pointer to input-/output- or diagnostic data
 - or response value according to the table if there is an error

Response Value	Explanation
0x0100	Command semaphore is not set
0x0005	wrong command sequence

Structure of the Data:

The data field (124 x 14 bytes= 1736 Bytes) consists of 124 structures for the slave addresses 0-123 (Index means Slave Address); the structure per slave is as follows:

The pointer values are pure offset values in reference to the start address of the DPRAM (that is, in order to be able to access the current address, the offset value has to be added to the start address respectively).

Variable	Name	Explanation
word	in_ptr	Offset pointer to start of the slave's inputs
word	outp_ptr	Offset pointer to the start of the slave's outputs
word	diag_ptr	Offset pointer to the start of the slave's diagnosis
word	diag_len_ptr	Offset pointer to the current diagnostic length byte
word	diag_cnt_ptr	Offset pointer to the diagnostic counter byte
byte	inp_len	Length of the inputs in bytes
byte	outp_len	Length of the outputs in bytes
byte	inout	Information about the consistency of the inputs/outputs
byte	type	Type of the slave

Table 20: Data structure

	Bit:	Description
Inputs:	7	0 = Not buffered / 1= Buffered
	6, 5	00 = without consistency 01 = short consistency 10 = long consistency 11 = reserved
	4	= 0
Outputs:	3	0 = Not buffered / 1= Buffered
	2, 1	00 = without consistency 01 = short consistency 10 = long consistency 11 = reserved
	0	= 0

Table 21: Variable inout

This information is set with COM ET200 and specifies the consistency setting of the slave. Access to the inputs/outputs of the slave is selected in accordance with this setting.

- Without consistency:** Direct access to the DPRAM possible
- Short consistency:** When consistent access to the DPRAM is used, the appropriate consistency signal must be set for read or write accesses.

Long consistency: Direct access to the DPRAM possible when consistency is not required
Buffered: The data are stored intermediately in the buffer and are consistent
 The data are stored intermediately in the buffer

The setting for consistency is available for inputs and outputs respectively. Consistent access is required when several bytes result in a value which must always be viewed and used within the context. The consistency setting for the slave is specified in the configuration of the slave.

Bit Position:	Value:	Designation:
7	0/1	IM180-Slave (=1)
6...3	---	reserved
2	0/1	Read_Output
1	0/1	Read_Input
0	0/1	XchangeData

Bit 0	Bit 1	Bit 2	Possible Settings:
1	0	0	XChangeData
0	1	0	Read_Input
0	0	1	Read_Output not possible at this time
0	1	1	Read_Input / Output ... not possible at this time

Table 22: Variable type

This information is set with COM PROFIBUS and specifies the slave operation selected. These settings can be used to operate the slave in normal operation (XChangeData) or in shared slave operation (Read_Input). See description of COM PROFIBUS for detailed information.

3.2.6.4 STOP Command

Command: Take the IM180 to the STOP mode
Command Byte: 04H
Command Data: as required

Response: Command repetition after execution
Response Length: 2
Response Data: refer to table below:

Response Value	Explanation
0x0000	Command executed correctly
0x0100	Command semaphore is not set

3.2.6.5 CLEAR Command

Command: Put IM180 to the CLEAR mode
Command Byte: 05H
Command Data: as required

Response: Command repetition after execution
Response Length: 2
Response Data: refer to table below:

Response Value	Explanation
0x0000	Command executed correctly
0x0100	Command semaphore is not set

3.2.6.6 OPERATE Command

Command: Put IM180 to the OPERATE mode
Command Byte: 06H
Command Data: as required

Response: Command repetition after execution
Response Length: 2
Response Data: refer to table below:

Response Value	Explanation
0x0000	Command executed correctly
0x0100	Command semaphore is not set

3.2.6.7 Start of Watchdog Monitoring

Command: Start of watchdog monitoring with processing of the watchdog cell
Command Byte: 07H
Command Length: 2
Command Data: Word value of the watchdog in units of 10ms each, The maximum value is 0XFFFFH
 Word value 0 means stopping of watchdog monitoring
Response: Command repetition after execution
Response Length: 2
Response Data: refer to table below:

Response Value	Explanation
0x0000	Command executed correctly
0x0100	Command semaphore is not set

This function is used to activate host monitoring via the IM 180. Cyclically at the parameterized time interval, the IM 180 checks the watchdog as shown below. If the entry is 0X00, the value 0XFF is entered. If the entry is 0XFF, the value 0XAA is entered, and the IM 180 is stopped with a system error since it is assumed that the host has failed.

The host must cyclically set the watchdog to the value 0X00 at least once within the parameterized time.

3.2.6.8 Transfer of Binary Parameter Data from Host to IM180

Command: Transfer of parameter assignment data from host to IM180 via DPRAM. There are further blocks, so that an additional identification is entered.
Command Byte: 88H for block with further block
 08H when transferring the last block
Command Length: Length of data
Command Data: Parameter assignment data in blocks of 250 bytes maximum

Response: Command repetition value = 88H or value = 08H
Response Length: 2
Response Data: refer to table below:

Response Value	Explanation
0x0000	Command executed correctly
0x0100	Command semaphore is not set

It is essential to perform a software reset or a hardware reset after the transmission.

3.2.6.9 Transfer of Binary Parameter Data from the IM180 to Host

Command: Transfer of parameter assignment data from the IM180 to host via DPRAM
Command Byte: 09H at start of request
 89H for follower block request
Command Data: as required
Response: Here, in addition to the command repetition, the highest bit is set to indicate that follower blocks will still follow (value = 89H). The last block is transferred without setting the highest bit (value = 09H) and thus, the last response is signalled.
Response Length: Length of the data, or 2 if there is an error
Response Data: Parameter assignment data in blocks of 250 bytes maximum, or response according to the table if there is an error

Response Value	Explanation
0x0100	Command semaphore is not set
0x0005	wrong command sequence

3.2.6.10 Commands SYNC / UNSYNC / FREEZE / UNFREEZE to Slaves

Command: Assign request to slave or slave groups
Command Byte: 10H
Command Length: 3
Command Data: - entering the request (SYNC / FREEZE etc.)
 - entering a group
 - entering an address

Data Byte	Meaning
Byte 0	Global Control Command
Byte 1	Group Number (enter FFH for Group 0)
Byte 2	Slave address or broadcast with 7FH

Table 23: Parameter data

Bit 5	Bit 4	Possible Settings:
0	0	no function
0	1	UNSYNC
1	0	SYNC
1	1	UNSYNC

Bit 3	Bit 2	Possible Settings:
0	0	no function
0	1	UNFREEZE
1	0	FREEZE
1	1	UNFREEZE

Bit 0,1,6,7 = 0

Table 24: Global-Control-Command-Byte

This command byte is used to specify the job.

Bit x	Groupnumber
0	1
1	2
2	3
3	4
4	5
5	6
6	7
7	8

Table 25: Group number byte

The group number byte is used to specify the groups to be addressed.

The address byte is used to specify whether only one slave is to be addressed or all slaves.

Remarks:

The slave to be addressed must have been entered with COM PROFIBUS in the group and for the command. See COM PROFIBUS description for detailed information.

Response: Command repetition after execution

Response Length: 2

Response Data: refer to table below:

Response Value	Explanation
0x0000	Command executed correctly
0x0100	Command semaphore is not set
0x0002	Global control command not permitted
0x0003	Command to group or slave not permitted

3.2.6.11 Command Set Slave Address to Slave

Command: Request to slave to change address

Command Byte: 11H

Command Length: >=3

- Command Data:**
- new slave address
 - flag about change possibility
 - old slave address
 - possible slave data

Data Byte	Meaning
Byte 0	New slave address
Byte 1	Address change ID
Byte 2	Old or current slave address
Byte 3...x	Additional slave data possible according to standard

Table 26: Parameter data

Address Change Identifier Byte	Value
Address can only be changed after initial program loading	<> 0
Address can also be changed later	== 0

Table 27: Address change identifier byte

Remarks:

The slave must have already been entered with the new address with COM PROFIBUS.

Response: Command repetition after execution

Response Length: 2

Response Data: refer to table below:

Response Value	Explanation
0x0000	Command executed correctly
0x0100	Command semaphore not set
0x0001	Slave can't process service
0x0002	Slave doesn't have resources
0x0003	Command not activated at slave
0x0005	Bus short circuit
0x009F	Slave doesn't respond
0x00AF	Slave responds wrong
0x00BF	Bus fault

3.2.6.12 Start of Signal Pulses

Command: Start of transmission of signal pulses via signal TESTO. Low pulses which are 200ns wide are transmitted continuously.

Command Byte: 12H

Command Length: 2

Command Data: Word value of the pulse intervals in units of 25.6 μ s;
Word value 0 means stopping the transmission of signal pulses

Response: Command repetition after execution

Length of Response: 2

Response Data: refer to table below

Response Value	Explanation
0x0000	Command executed correctly
0x0100	Command semaphore is not set

3.2.6.13 Command Set Outputs (for consistency over 122 bytes length)

Command: Job so that output data, which are consistent and longer than 122 bytes, will be accepted by the IM 180. See the slave data structure for how to set the slave outputs.

Command Byte: 13H
 Command Length: 1
 Command Data: Slave address

Response: Command repetition after execution
 Length of Response: 2
 Response Data: refer to table below

Response Value	Explanation
0x0000	Command executed correctly
0x0004	Wrong command length
0x0007	Slave is not in DATA status.
0x0017	IM 180 as slave is not in DATA status.
0x0018	Master is in STOP status.
0x001d	Last slave data not yet sent
0x001e	No entry in slave for buffering
0x001f	Last slave data not yet sent
0x0020	Last slave data not yet sent
0x0100	Command semaphore not set
0x0300	Master software not activated

3.2.6.14 Command Read Inputs (data more than 122 bytes length)

Command: Job so that input data longer than 122 bytes will be transferred by the IM 180 to the DPRAM

Command Byte: 14H
 Command Length: 1
 Command Data: Slave address

Response: Command repetition after execution
 Length of Response: 2
 Response Data: refer to table below

Response Value	Explanation
0x0000	Command executed correctly
0x0004	Wrong command length
0x0007	Slave is not in DATA status.
0x0017	IM 180 as slave is not in DATA status.
0x0018	Master is in STOP status.
0x001d	Last slave data still current
0x001e	No entry in slave for buffering
0x0020	Last slave data still current
0x0100	Command semaphore not set
0x0300	Master software not activated

3.2.6.15 Command Set Slave Address to Slave unchecked

Command: Job to slave to change the address
 Command byte: 15H
 Command length: ≥ 5
 Command data:

- New slave address
- Flag for address change capability
- Old slave address

- Ident number, low-byte
- Ident number, high-byte
- Any slave data

Data Byte	Meaning
Byte 0	New slave address
Byte 1	Address change ID
Byte 2	Old or current slave address
Byte 3	Ident number, high-byte
Byte 4	Ident number, low-byte
Byte 5...x	Additional slave data possible according to standard

Table 28: Parameter data

Address Change Identifier Byte	Value
Address can only be changed after initial program loading	<> 0
Address can also be changed later	== 0

Table 29: Address change identifier byte

Response: Command repetition after execution
 Response Length: 2
 Response Data: refer to table below:

Response Value	Explanation
0x0000	Command executed correctly
0x0001	Slave can't process service
0x0002	Slave doesn't have resources
0x0003	Command not activated at slave
0x0005	Bus short circuit
0x009F	Slave doesn't respond
0x00AF	Slave responds wrong
0x00BF	Bus fault
0x00C6	Slave responds incorrectly
0x0100	Command semaphore not set
0x0300	Master software not activated

3.2.6.16 Fetch Consistent Overview Diagnosis

Command: Fetch consistent overview diagnosis
 Command Byte: 16H
 Command Length:
 Command Data:

Response: Command repetition after execution
 Length of Response: 64 or 2 when error occurs
 Response Data: Overview diagnosis in acc. w. description in chap. 3.2.3 or, for errors, see following table.

Response Value	Explanation
0x0000	Command executed correctly
0x0100	Command semaphore is not set

3.2.6.17 Fetch Consistent Slave Diagnosis

Command: Fetch consistent slave diagnosis
 Command Byte: 17H
 Command Length: 1
 Command Data: Slave address

Response: Command repetition after execution
 Length of Response: Length of diagnosis or 2 for errors
 Response Data: Slave diagnosis in acc. w. description in chap. 3.2.2.1.1 or, for errors, see following table.

Response Value	Explanation
0x0005	Slave not entered in COM PROFIBUS
0x0100	Command semaphore is not set
0x0300	Master software not activated

3.2.6.18 Set Slave Diagnosis on IM 180 Slave

Command: Set slave diagnosis on IM 180 slave
 Command byte: 18H
 Command length: 1 to 3
Command data: Type of diagnosis
 Any value of the first extended diagnostic byte
 Any value of the second extended diagnostic byte

Bit 0	Bit 1	Bit 2	Available Settings
0	0	0	Reset subsequent diagnostic bits or report status
1	0	0	Set extended diagnostic bit
0	1	0	Set static diagnostic bit
0	0	1	Set diagnostic overflow bit

Table 30: Diagnostic type variable

Response: Command repetition after execution
 Length of Response: 2
 Response Data: see following table

Response Value	Explanation
0x0000	Command executed correctly
0x0004	Wrong data length
0x0005	Wrong slave address
0x0100	Command semaphore not set
0x0300	Slave software not activated

3.2.6.19 Issue DP Command

Command: This DP command can be used to execute the "read data record" and "write data record" commands. This permits certain data to be acyclically sent to or fetched from certain slaves later.

Command Byte: 19H
 Command Length: ≥ 10
 Command Data:

Command Data	Explanation
Byte	Job identifier
Byte	Address of the receiver
Byte	Parameter record number
Byte	Reserved
Word	Identifier
Word	Length of sending data
Word	Maximum length of receiving data
Bytes 1 to 240	Possible sending data

Table 31: Command data structure

Response: Command repetition after execution
 Length of Response: > =6
 Response Data: see following table.

Response Data	Explanation
Word	Response value
Byte	Error byte 1 (slave-related)
Byte	Error byte 2 (slave-related)
Byte	Error byte 3 (slave-related)
Byte	Error byte 4 (slave-related)
Byte 1 to 240	Possible receiving data

Response Value	Explanation
0x0000	Command executed correctly
0x0004	Wrong data length
0x0100	Command semaphore not set
0x0300	Master software not activated
0x8021	Job still active
0x8022	Job not permitted
0x8023	Incorrect parameters
0x8024	Error during request for memory
0x8026	Timeout expired
0x8028	Invalid length entered
0x8030	Identifier NA, RS, RR UE, RDL, and RDH. See EN 50170.
0x80C1	Identifier FE. See EN 50270.
0x80C2	Identifier NI. See EN 50270.
0x80C3	Identifier AD. See EN 50270.
0x80C4	Identifier EA. See EN 50270.
0x80C5	Identifier LE. See EN 50270.
0x80C6	Identifier RE. See EN 50270.
0x80C7	Identifier IP. See EN 50270.
0x80C8	Identifier SC. See EN 50270.
0x80C9	Identifier SE. See EN 50270.
0x80CA	Identifier NE. See EN 50270.
0x80CB	Identifier DI. See EN 50270.
0x80CC	Identifier NC. See EN 50270.

Below is a list of the entries for the applicable commands.

The following data must be entered for the "read data record" command.

Command Data	Explanation
Byte	0x22
Byte	Address of the receiver
Byte	Slot number of the module
Byte	Disregard
Word	Data record number
Word	Disregard
Word	Maximum length of the receiving data

Table 32: "Read data record" command

The following data must be entered for the "write data record" command.

Command Data	Explanation
Byte	0x23
Byte	Address of the receiver
Byte	Slot number of the module
Byte	Disregard
Word	Data record number
Word	Length of the sending data
Word	Disregard
Bytes 1 to 240	Sending data (depends on the length of the sending data)

Table 33: "Write data record" command

3.2.6.20 Issue Mark Command

Command: Issue mark command. The response of the command is available after the master has performed one data cycle.

Command Byte: 20H

Command Length:

Command Data:

Response: Command repetition after execution

Length of Response: 2

Response Data: see following table.

Response Value	Explanation
0x0000	Command executed correctly
0x000a	Master is in STOP mode.
0x0100	Command semaphore not set
0x0300	Master software not activated

3.2.6.21 Fetch Master Information

Command: Fetch master information.

Command Byte: 21H

Command Length:

Command Data:

Response: Command repetition after execution

Length of Response: 26

Response Data: see following table.

Response Structure	Explanation
Byte	Bus address of the IM 180
Byte	Set HSA address
Word	Reserved
Word	Reserved
Word	Baud rate identifier
Word	Desired token rotation time (time = value x 256 x Tbit)
Word	MinSlaveIntervall (time = value x 256 x Tbit)
Word	Slot time
Word	Idle time 1
Word	Idle time 2
Word	Ready time
Byte	Wait for idle time
Byte	Retry factor for token telegrams
Byte	Retry factor for data telegrams
Byte	GAP update factor
Byte	Reserved
Byte	Reserved

Baud Rate Identifier	Baud Rate
0000	12 MB
0001	6 MB
0002	4 MB
0003	3 MB
0007	1,5 MB
0015	750 KB
0023	500 KB
0063	187,5 KB
0127	93,75 KB
0624	19,2 KB
1249	9,6 KB

Table 34: Baud Rate Value

3.2.7 Special Response Message

Response message if a system error is to generate a message according to reset parameter

Response: Message with value = 7FH

Response Length: 10

Response Data: System error data as present in the diagnostic overview.

3.2.8 Unknown Call

Command : Value unequal to the previous values

Command Length: as required

Command Data: as required

Response: Command repetition

Length of Response: 2

Response Data: 0x0200

3.3 Access Procedure

User access to the DPRAM depends on several factors. Since certain areas of the DPRAM can be continuously read and write-accessed by both sides, the following points must be taken into consideration. Depending on the type of user access (i.e., access by byte or word), the DPRAM controller already performs a hardware check of the consistency of the byte or word since accesses to the IM 180 side are always by word. Otherwise, the information below applies.

3.3.1 Diagnostic Overview Channel Data

The IM 180 continuously updates the system diagnostic area, while new data are only written to the data transfer list approximately every three data cycles. When the user accesses certain areas, the user is supplied with the present value. When the user wants to have the complete status at a certain point in time, the status must be fetched via the communications channel with the command described in chap. 3.2.6.16.

3.3.2 Slave Diagnostic Data

The IM 180 updates the slave diagnostic data continuously and then increments the diagnosis counter. Before and after access to slave diagnoses, the diagnosis counter must be read out and a check performed to determine whether new data were entered during the access (i.e., whether inconsistency occurred). If the user wants to be sure that the slave diagnosis is consistent, this diagnosis must be fetched via the communications channel with the command described in chap. 3.2.6.17.

3.3.3 Slave Input Data and Output Data

The IM 180 also permits the ASPC2 ASIC to directly write-access the DPRAM up to certain data lengths and consistency sizes. The rest of the data is then stored intermediately in the RAM of the IM 180 and transferred by the CPU of the IM 180 to the DPRAM on request. Based on the following table, the type of consistency is set by COM PROFIBUS and can be read by the user from the structure of the slave info data (see table 35). Based on this information, the access procedure is specified for both the IM 180 and the host and must be adhered to by both sides.

	Without Consistency			With Consistency		
	I	O	I/O	I	O	I/O
Inputs or outputs						
Total telegram length	<= 122	> 122	<= 244	<= 122	> 122	> 122
Longest consistent area	1	1	1	<= x	> x	> 1
Type of consistency	None	Buffered	None	Short	Long	Long

x Consistency limit (can be entered for every Baud rate in the master type file of the IM 180)

Table 34: Consistency setting

The lengths of the individual consistent areas of a slave can only be read from the configuration byte specifications. For a slave, short consistency is already entered when word consistency is set for an area.

3.3.3.1 Without Consistency

When this type of access is used, only the controller of the DPRAM is activated for byte and word access.

3.3.3.2 Short Consistency

In addition to the byte/word consistency already ensured by the DPRAM, extended data consistency is required for large amounts of data (e.g., to transfer an analog value consisting of several bytes or similar situations).

This method can only be used for small amounts of data up to the consistency limit. When this method is used, the ASPC2 ASIC as bus master accesses the DPRAM directly to fetch consistent data for data transmission via PROFIBUS or to write consistent data there. The control in this case is performed by means of special signals at the host interface, and the ASPC2 and a HW consistency control.

This method permits a faster update of the values than does "long" consistency.

In the case of short consistency, the CPU itself does not directly intervene.

The following SW-preconditions apply to short consistency:

- In the DPR, there are areas defined by software to which, by (SW-) definition, only consistent accesses are permitted by both sides (is not checked by the hardware, however).
- Each DPR byte is only for data transmission in one direction (host to Profibus or vice versa). The only exception to this is the DPR's communication channel.
- During a consistent access by one side, normal accesses by the other side are permitted.
- **One side** is either writing or reading consistently at a certain time; both at the same time is not permitted.

In reference to short consistency, the following access combinations to the DPR are conceivable:

Host	ASPC2	Comment
access not consistent (reading or writing)	access not consistent (reading or writing)	Only the DPR's conflict control is active
access not consistent (reading or writing)	access consistent (reading or writing)	No conflict possible because of different address areas
access consistent (reading or writing)	access not consistent (reading or writing)	No conflict possible because of different address areas
consistent reading	consistent reading	Not critical, since no data is changed; therefore, possible from both sides
consistent writing	consistent writing	Not critical, since write accesses always have to be made on different addresses
consistent writing	consistent reading	Conflict case; HW consistency control at intervention
consistent reading	consistent writing	Conflict case; HW consistency control at intervention

3.3.3.2.1 Critical System Performance

To achieve short data consistency, there should be no consistent writing to the DPR from the one side, and consistent reading from the other. This is achieved by one side having to wait for the other (Ready withdrawal).

However, the ASPC2 is only to be disabled like this for a short. If the ASPC2 is disabled longer, this may cause an error state on the Profibus.

The longer this time is, and the faster the host system is, the more data can be transmitted by means of short consistency.

Sequence in the case of "short" consistency:

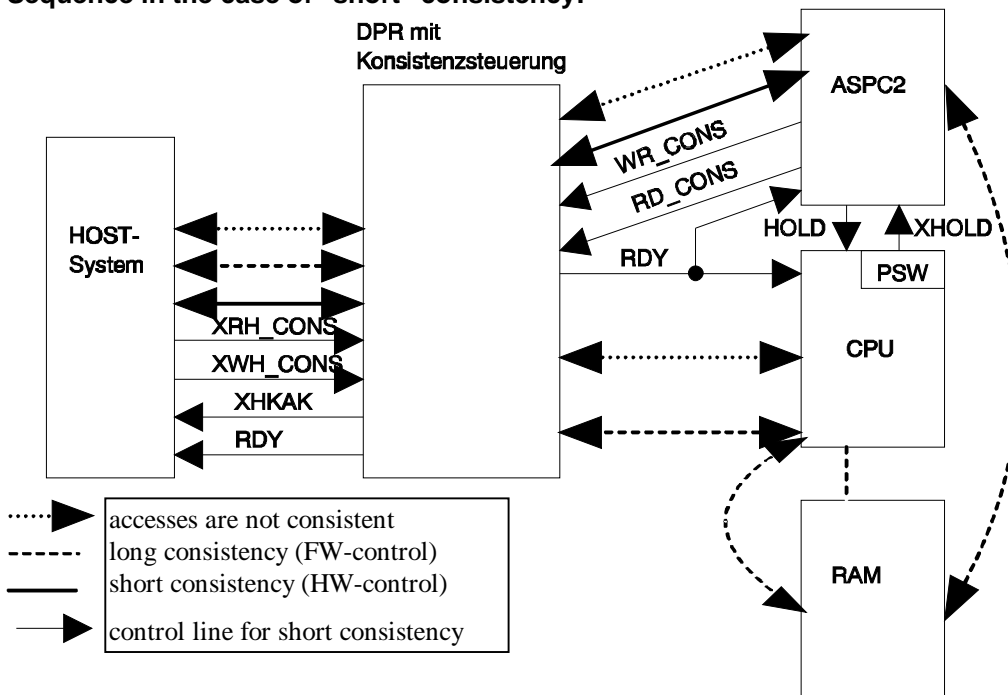

Requirements for Consistency Control:

- o If both sides request a consistent access simultaneously, the following priority applies if there is a conflict:
 1. ASPC2
 2. host side
- o A running consistent access can't be interrupted by a request with a higher priority.
- o If the host side requests a consistent write access, the host-side can still also read the DPR normally (the same applies to "consistent read accesses").
- o If the host-side requests a consistent access, then every access to the DPR by the host-side (also to the semaphore register) is extended to XHKAK (= host consistency acknowledge) active Ready. The Ready signal in this case is activated by applying XCSHOST.

Starting of a Consistent Data Transfer from the Host-Side:

1. With the signal "XWH-CONS", the host requests a consistent write access to the DPR, or with "XRH-CONS" a read access.
 2. If there is no conflict (refer to: Non-consistent / Consistent Accesses, p. 40), the consistency control will then enable the consistent access to the DPR with the signal XHKAK (host consistency acknowledge).
 3. The host can either wait for the signal XHKAK in order to be able to access the DPR without Ready withdrawal, or it makes the access immediately and -if there is a conflict- will be halted until XHKAK via Ready withdrawal.
 4. After completion of the consistent accesses, the host deactivates the signal "XWH-CONS" or "XRH-CONS"; as response to this, the consistency control deactivates the signal XHKAK.
- o If, in the meantime, the ASPC2 wants to make a consistent access to the DPR and if this access represents a conflict case, there will be a Ready withdrawal for the ASPC2 (refer to figure: Consistent Accesses, p. 42).

Starting of a Consistent Data Transfer by the ASPC2:

1. The ASPC2 obtains the bus via the HOLD/HOLDA mechanism.
2. Via RD_CONS and WR_CONS, the ASPC2 signals a consistent data transfer.
3. If there is no conflict, the ASPC2 can immediately access the DPR. If there is a conflict, the ASPC2 is halted via Ready until the conflict has been resolved. During the conflict, the signal A_CONS becomes active at the host interface. If there is a conflict, the host has a small period of time to end the accesses after A_CONS became active to complete its accesses.
4. After the data transfer, the ASPC2 returns the bus to the CPU.

3.3.3.2.2 Lockout Time

If the host is making a consistent access to the DPRAM, the ASIC is locked out if it attempts an access at the same time. The IM180 signals this with A_CONS. From that time on, the ASPC2 has to wait for the consistency to be cancelled {?}, and can't perform any other activities. The maximum lockout time is calculated as follows:

1. It should be regarded that during the A_CONS signal, the ASIC doesn't transmit messages via the Profibus. Since all Profibus partners constantly monitor the timing during their communication, it may happen that faulty performance by the device is assumed if the lockout time of the ASPC2 master is too long.

- 1.1 Remember to consider the "timeout" time if other masters are being used on the bus. This time is calculated with the formula shown below.

$$T_{\text{Timeout}} = (2 \times \text{master address} + 6) \times T_{\text{Slot}}$$

T_{Timeout} : This time is used to monitor bus activity. Monitoring starts when the last bit of a telegram is received and ends when the first bit of a subsequent telegram is received.

T_{Slot} : The maximum time which the initiator waits (after sending the last bit of a call telegram) for the complete receipt of the first telegram character of the immediate acknowledgment or response

If the "timeout" time is exceeded while the ASPC2 is locked out, the bus is considered inactive for other masters, and appropriate activities are performed.

- 1.2 This time must be considered when slaves with response monitoring are used. The time is transferred to the slaves in the parameter telegram.

T_{WD} : Response monitoring for the DP slave ensures that the outputs assume a defined state during a master failure after expiration of this time.

If response monitoring is exceeded while the ASPC2 is locked out, the master is also considered for these slaves as failed and they assume a defined state.

2. In addition, remember that, during the A_CONS signal, CPU actions are not possible since the ASPC2 no longer releases the system bus on the IM 180.

This means that no calls to the IM 180 can be processed. In addition, the internal watchdog of the CPU can no longer be retriggered. After the watchdog time expires, the module is reset with the system error message indicating a **illegal reset**.

T_{watchdog} : A software reset is performed by the CPU after expiration of this time.

The present setting is 419 msec.

To ensure safe and reliable operation, use the appropriate times for the calculation of the maximum lockout time based on the application. When the settings in the COM ET200 Windows parameterization software are used, you can read the slot time and the response monitoring time directly.

If you also consider the access time of your host, you can calculate the number of bytes which you can process during a lockout procedure in the DPRAM until the above problems may begin.

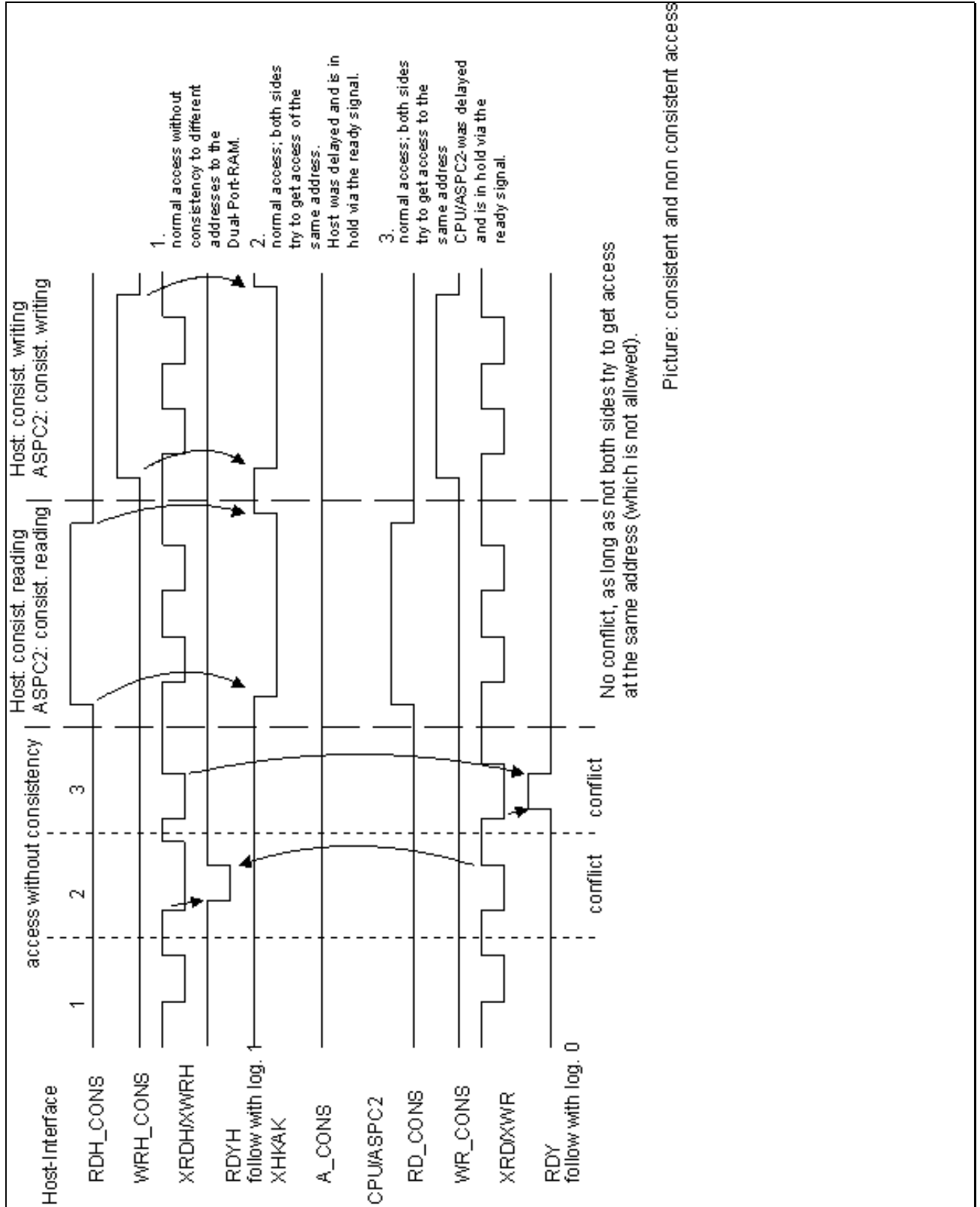

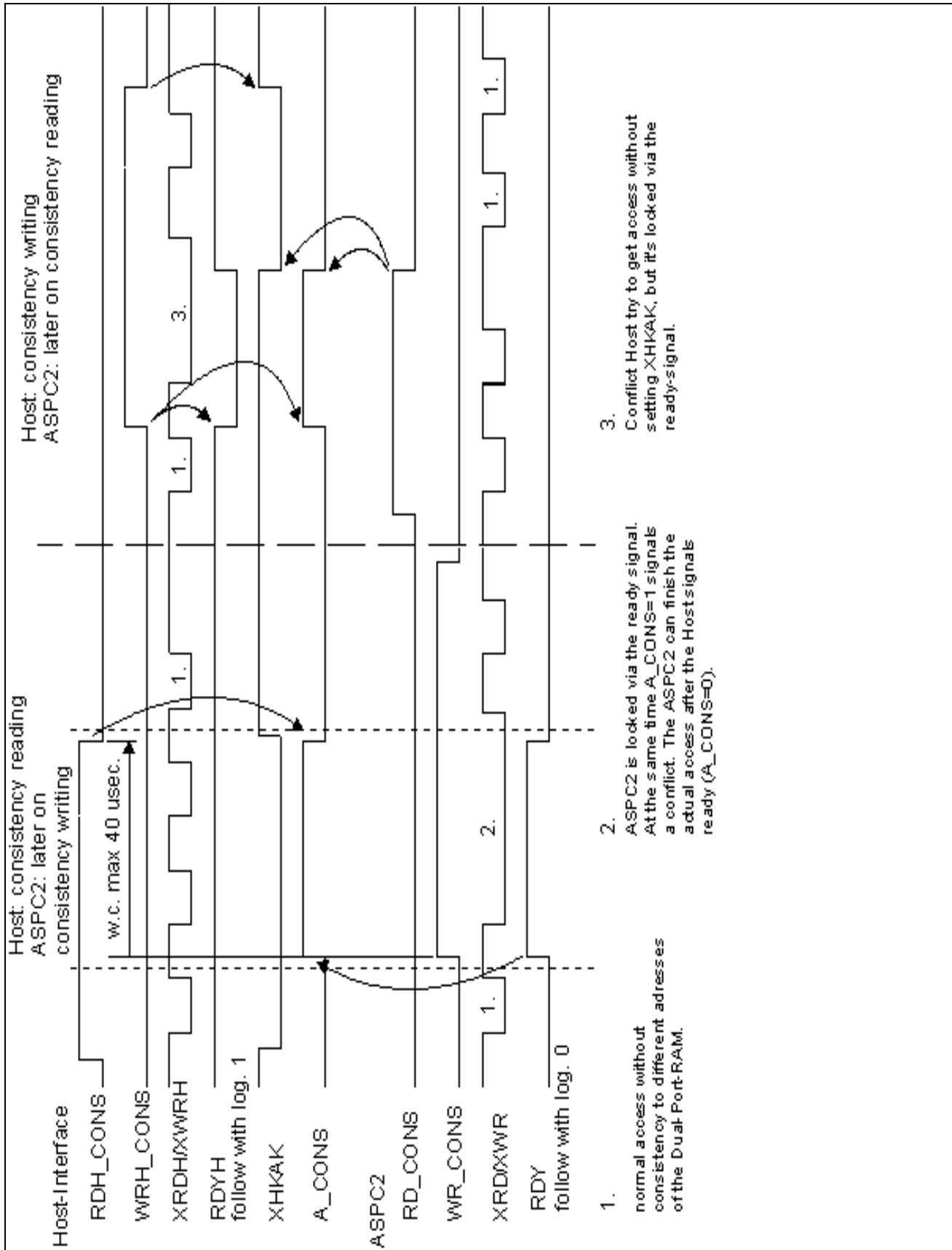

Figure 9: Consistent / Non-Consistent Accesses

3.3.3.2.3 Ordering for access to short Consistency with IM181

- Set Consistency Signal RCONS for reading or WCONS for Writing.
- Write or read first Byte or Word.
- Proof the Signal TIME in Register 3.
- If the Signal == 1, than repeat the Write or Read command.
- If the Signal == 0, than was the Write or Read correct.
- Reading or Writing the rest of Bytes or Words.
- Reset the Consistency Signal RCONS or WCONS.

3.3.3.3 Long Consistency

This method is set under certain circumstances. See table 35. When this method is used, the ASPC2 ASIC first stores the data of and for PROFIBUS intermediately in the normal RAM of the module. When required, the host can then use a SW request to cause the CPU to transfer the data between the dual port RAM and the normal RAM.

3.3.3.4 Buffering

This method is set under certain circumstances. See table 35. When this method is used, the ASPC2 ASIC first stores the data of and for PROFIBUS intermediately in the normal RAM of the module. When required, the host can then use a SW request to cause the CPU to transfer the data between the dual port RAM and the normal RAM.

3.3.4 Setting Outputs for Long Consistency

Since the data are also held in the IM 180 RAM for long consistency, buffering does not need to be handled differently. The procedure is shown below.

- Write desired data in the DPRAM (no access from the IM 180 side at present).
- Send the "set outputs" command (chap. 3.2.6.13) to the IM 180.
- Wait until the command has been executed.

3.3.5 Reading Inputs for Long Consistency or Buffering

Since the data are also held in the IM 180 RAM for long consistency, buffering does not need to be handled differently. The procedure is shown below.

- Send the "read inputs" command (chap. 3.2.6.14) to the IM 180.
- Wait until the command has been executed.
- Read current data from the DPRAM (no access from the IM 180 side at present).

4 Putting into operation

The following steps are required to commission the IM 180.

- Circuit the RS 485 (otherwise the module cannot assume the state for receiving commands via the communications channel).
- Set up the DPRAM communication wiring with the ready signal.
- Wire the reset signal.
- Additional signals are optional.
- Apply the voltage supply.
- The IM 180 is provided with a default configuration which permits the following actions to already be performed even when in STOP status.
 - * The IM 180 is master with the address 1.
 - * The IM 180 sends token telegrams at a Baud rate of 19.2 KB.
- The following actions are performed when the IM 180 with the default configuration is switched to the CLEAR or OPERATE state.
 - * The IM 180 addresses a slave with the address 3.
 - * The IM 180 parameterizes the slave with ident number 0x0008.
 - * The IM 180 sends configuration bytes 0x13/0x23 (4 bytes of I/O).
- This corresponds to a slave with SPC3 and its sample program.

5 User Program

5.1 Transmission of Binary Data

The following procedure is recommended when new binary data are transferred to the IM 180.

- Start up the IM 180 until STOP is detected in the status byte.
- If the IM 180 is already in operation, switch to STOP status.
- Transfer the file to the IM 180 via the DPRAM or via PROFIBUS.
- Reset the module using either a HW or SW reset.

The parameters are stored in the internal Flash EPROM and are retained even when the power is turned off.

5.2 Master Operation

- Wait during startup until the status byte indicates the STOP state.
- Perform cyclic check of the first error word at address 0x3EF0 in the DPRAM. This polling can be omitted when interrupts are used if the "software reset of the IM 180" command contains the setting that a message is to be transferred via the communications channel when a system error occurs.
- The connection to the slaves can now be established by changing the state to CLEAR or OPERATE.
- By polling the info byte, it can be determined whether data communication is being performed with all slaves.
- In addition, the overview diagnosis can be used to determine the slaves for which diagnoses are available and then obtain more detailed information on the slave with the slave diagnoses.
- The address and type of access for setting the outputs and reading the inputs of the slaves are supplied from the slave info data of the IM 180 and must then be performed.
- Watchdog monitoring can be activated if desired.
- Master-related commands are also possible.

5.3 Slave Operation

- Wait during startup until the status byte indicates the STOP state.
- Perform cyclic check of the first error word at address 0x3EF0 in the DPRAM. This polling can be omitted when interrupts are used if the "software reset of the IM 180" command contains the setting that a message is to be transferred via the communications channel when a system error occurs.
- The change in state to CLEAR or OPERATE starts the slave software.
- By polling the slave status byte, the state of the IM 180 as slave can be determined.
- By polling the slave info byte, the state of the parameterizing master can be determined (i.e., CLEAR or OPERATE).
- The address and type of access for setting the outputs (inputs for the parameterizing master) and reading the inputs (outputs for the parameterizing master) as slave are supplied from the slave info data of the IM 180 and must then be performed.
- The "set slave diagnosis in IM 180 slave" command can be used to supply the parameterizing master with certain information on the diagnosis.
- Watchdog monitoring can be activated if desired.

5.4 Master-Slave Operation

- Both master and slave procedures are performed here.

6 COM PROFIBUS

When the IM 180 is used, COM PROFIBUS is required as the parameterization software. This software runs under Windows 3.1 to Windows 95.

Master functionality requires master type file SI0008AX.2MH (contains settings for the master such as consistency limit for each Baud rate and so on) and file IM180.BMP which is already included in the software package starting with version 2.

Slave functionality is also available starting with firmware version V3.0 of the IM 180. This requires slave type file SI8080AX.200.

In addition, the ONLINE functions of the COM PROFIBUS package can be utilized starting with IM 180 firmware version V3.0. This requires a more recent master type file (SI8080AX.2MH) and COM PROFIBUS starting with version V3.0 and a special master card (e.g., CP 5411).

If you cannot find the IM 180 master in this software, contact the offices listed in chap. 10.1 for help. The master type files must be copied to subpath MASTERS and the slave type files to subpath TYPDAT5X of COM PROFIBUS if not already available there.

6.1 Settings

Depending on the COM PROFIBUS setting, different software packages are activated on the IM 180 and, depending on that, various calls are possible. This information is located in the binary file.

Starting with version V3.0, the ONLINE functions can also be used. If so, this package is always activated and offers the following functions.

- Fetch overview diagnosis of IM 180
- Fetch slave diagnoses of IM 180
- UPLOAD the binary file of IM 180
- DOWNLOAD the binary file to IM 180
- Activate the binary data in IM 180

Below you will find information on the various settings available for the IM 180 and the slaves. The procedure to be used is explained in the COM PROFIBUS description for the IM 308C and can be applied directly to the IM 180.

6.1.1 IM 180 Master

- Master software activated
- DP command software activated
- System diagnosis, master status and data transfer list are updated.
- Actions on PROFIBUS for the following states

Status	Explanation
OFFLINE	IM 180 as master does not send data to PROFIBUS.
STOP	IM 180 as master is in token handling.
CLEAR	IM 180 as master sends clear telegrams to slaves.
OPERATE	IM 180 as master sends user data telegrams to slaves.

- The outputs of parameterized slaves are cleared under the following conditions.
 - + Transition of the slave state from DIAG1 to WAIT-PRM
 - + Transition of the slave state from DIAG2_STATUS to DIAG2
 - + Transition of the master state from OPERATE to CLEAR

6.1.2 IM 180 Slave

- Slave software activated
- Slave status byte and slave info byte are updated.
- The identifier for the IM 180 slave is available in the slave info data.
- Outputs in the DPRAM correspond to the inputs of the parameterizing master.
- Inputs in the DPRAM correspond to the outputs of the parameterizing master.
- Access mechanisms for setting and reading inputs/outputs are same as for master.
- Slave diagnosis of the IM 180 can be set.
- Slave diagnosis of the IM 180 cannot be read from the DPRAM.
- Actions on PROFIBUS for the following states

Status	Explanation
OFFLINE	IM 180 as slave does not send data via PROFIBUS.
STOP	IM 180 as slave does not send data via PROFIBUS.
CLEAR	IM 180 as slave is active.
OPERATE	IM 180 as slave is active.

- The inputs of the slave are cleared under the following conditions.
 - + Slave state WAIT-CFG
 - + Global control command from the parameterizing master

6.1.3 IM 180 Master/Slave

- The IM 180 performs all points for master and slave.
- Actions on PROFIBUS for the following states

Status	Explanation
OFFLINE	IM 180 does not send data via PROFIBUS.
STOP	IM 180 as master is in token handling. IM 180 as slave only sends RS to parameterizing master.
CLEAR	IM 180 as master sends clear telegrams to slaves. IM 180 as slave is active.
OPERATE	IM 180 as master sends user data telegrams to slaves. IM 180 as slave is active.

6.1.4 Shared Slaves

Using this setting, slaves which have another parameterization master can be activated in the master software so that the inputs can be entered in the DPRAM of the IM 180. The IM 180 fetches the inputs cyclically with the READINPUT command.

6.2 Parameter File

The parameter binary file which is required for the IM 180 must correspond to the structure which can be generated by the COM PROFIBUS parameterization software. See the manual for this software for detailed information on setting the parameters and settings for the slaves.

The binary file is created by calling DATEI-EXPORT-BINÄRDATEI. When the ONLINE functions are used, the binary data can also be transferred via PROFIBUS to the IM 180.

7 IM181

7.1 General

The host interface between the IM180 and an AT-compatible computer, as well as the connection of the CP to an RS485 is on the AT carrier module (AT = user technology).

The address decoder of the AT carrier module decodes a 16kByte address window from the PC/AT address space. Via the 16kByte of this address window, the DualPort RAM can be accessed. HW-registers on the AT carrier module can be addressed via the port address area.

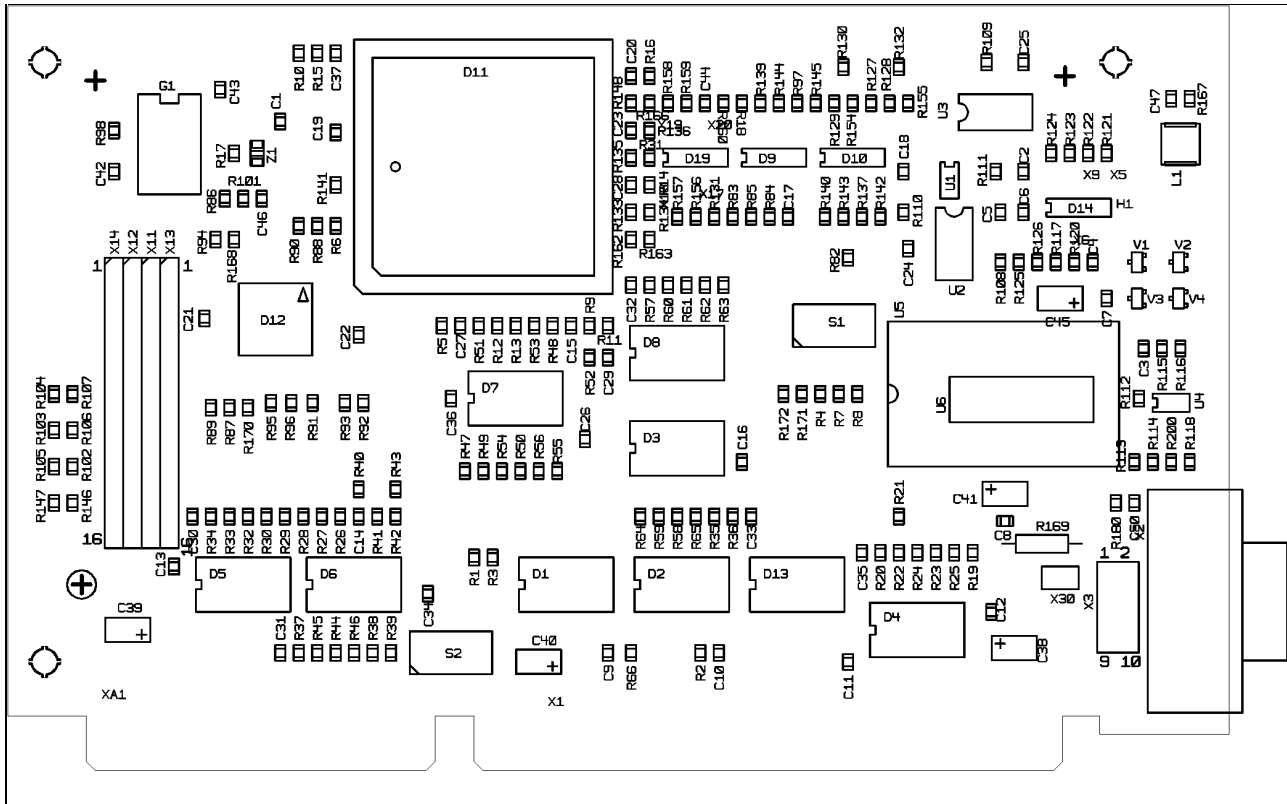

Figure 10: IM181

7.2 Setting the Module Address in the PC/AT Address Space

All settings for the modules can be performed with the DIP switches S1 and S2 (refer to Figure 10: IM181)

7.2.1 DPRAM Area

DPRAM Area	S 1.1	S 1.2	S 1.3
C8000 - CBFFF	ON	OFF	ON
CC000 - CFFFF	ON	OFF	OFF
D0000 - D3FFF	OFF	ON	ON
D4000 - D7FFF	OFF	ON	OFF
D8000 - DBFFF	OFF	OFF	ON
DC000 - DFFFF	OFF	OFF	OFF

Table 36: DPRAM Address Area

Type of Access:	S1.4
8-Bit-access	OFF
16-Bit-access	ON

Table 37: Types of access

To avoid access problems when using additional ISA-cards in the same segment, you can set these cards to 8-bit access. Remember, however, that this will reduce word-access speed.

7.2.2 I/O Address Area

Port Address Area	S 1.5	S 1.6	S 1.7	S 1.8
220 - 22F	ON	OFF	ON	ON
230 - 23F	OFF	OFF	ON	ON
240 - 24F	ON	ON	OFF	ON
250 - 25F	OFF	ON	OFF	ON
260 - 26F	ON	OFF	OFF	ON
320 - 32F	ON	OFF	ON	OFF
330 - 33F	OFF	OFF	ON	OFF
340 - 34F	ON	ON	OFF	OFF
350 - 35F	OFF	ON	OFF	OFF

Table 38: I/O Address Area

7.2.3 Interrupt Channel

Channel	S 2.1	S 2.2	S 2.3	S 2.4	S 2.5	S 2.6	S 2.7	S 2.8
3	ON	OFF	OFF	OFF	OFF	OFF	OFF	OFF
5	OFF	ON	OFF	OFF	OFF	OFF	OFF	OFF
7	OFF	OFF	ON	OFF	OFF	OFF	OFF	OFF
10	OFF	OFF	OFF	ON	OFF	OFF	OFF	OFF
11	OFF	OFF	OFF	OFF	ON	OFF	OFF	OFF
12	OFF	OFF	OFF	OFF	OFF	ON	OFF	OFF
14	OFF	OFF	OFF	OFF	OFF	OFF	ON	OFF
15	OFF	OFF	OFF	OFF	OFF	OFF	OFF	ON
none	OFF	OFF	OFF	OFF	OFF	OFF	OFF	OFF

Table 39: Interrupt number

7.2.4 Jumper Settings

Meaning:	Jumper X30
Connection of GND with RS485-GND	gesteckt
no connection of GND with RS485-GND	offen

Table 40: Jumper

All gray-shaded cells indicate the DEFAULT setting

7.3 Memory Distribution

The table below shows the memory distribution on the AT carrier module:

Address / Address Area	Access	Function
Basic Address + 0h to	Read/Write	DualPort-RAM of the
Basic Address + 3FFFh		IM180 (16k-Byte)

7.4 Register Description

7.4.1 Address Assignment

Eight port addresses are needed for the carrier module.

Address / Address Area	Designation	Function
Basic Address + 0h	Register 1	Consistency setting
Basic Address + 1h	Register 2	Reset and identification byte
Basic Address + 2h	Register 3	Interrupt source
Basic Address + 3h	Register 4	reserved
Basic Address + 4h	Register 5	reserved
Basic Address + 5h	Register 6	XTESTO
Basic Address + 6h	Register 7	reserved
Basic Address + 7h	Register 8	reserved

7.4.1.1 Register 1

Bit	7	6	5	4	3	2	1	0
Signal	free	free	free	free	free	res	WCONS	RCONS

Description:

Bit 0 RCONS

Set data-consistent reading for DualPort RAM accesses; that is, if subsequently the DPRAM is read, the signal XRH_CONS is generated on the IM180, and the signal IHKAK is awaited. If this signal arrives within 2.5 μ s, the reading access to the DPRAM is consistent, and the ASIC can't access the DPRAM in the writing mode in the meantime. Only by resetting this signal is consistent reading switched off again.

Level	Meaning
0	Data-consistent reading is switched off
1	Data-consistent reading is switched on

Bit 1 WCONS

Set data-consistent writing for DualPort RAM accesses; that is, if subsequently the DPRAM is pwritten to, the signal XWH_CONS is generated on the IM180, and the signal IHKAK is awaited. If this signal arrives within 2.5 μ s, the writing access to the DPRAM is consistent, and the ASIC can't access the DPRAM in the reading mode in the meantime. Only by resetting this signal is consistent writing switched off again.

Level	Meaning
0	Data-consistent writing is switched off
1	Data-consistent writing is switched on

Recognize:

The ASPC2 is locked (access to the DPRAM) by using of the short consistency and that means you have to finish the consistency access as soon as possible.

7.4.1.2 Register 2

Description:

Access:	Hex Value	Explanation
Reading	xxh	Identification byte of the carrier module for recognition
Writing	21h	Perform hardware reset for the IM180

7.4.1.3 Register 3

When an interrupt occurs, the corresponding bit is set. By setting the interrupt channel it can be specified which hardware interrupt number is triggered at the PC.

Attention: Reading out the register resets all assigned bits.

Bit	7	6	5	4	3	2	1	0
Signal	free	free	free	free	TIME	TEST	IM180	CONS

Description:

Bit 0 CONS

This bit is activated by setting the signal A_CONS of the IM180; that is, with the consistency logic signal, the ASPC2 signals an access request to the DPRAM which is momentarily locked out. The ASIC can, at the most, be locked out by the consistency logic, so that there won't be faulty performance.

This is a user responsibility.

Bit 1 IM180

This bit is triggered by the IM180 writing to the semaphore register of the DPRAM; that is, the response to a request by the IM180 generates an interrupt by the DPRAM. {?} After that, this cell has to be read out, which also acknowledges the interrupt.

Bit 2 TEST

This bit is activated by setting the test mode output (XTESTo) of the IM180; that is, this signal is used for test purposes and for periodic pulses of the IM180.

Bit 3 TIME

This bit is set by the carrier module if the signal IOCHRDY was activated too long; that is, at a consistent access to the DPRAM, a consistency request is made to the IM180, and the signal XHKAK is awaited. If this signal doesn't arrive within the specified time, the access is cancelled. Thus, after the **first consistent** data access, this bit is to be checked if consistency is set, because this access may possibly have been aborted and wasn't executed for that reason.

7.4.1.4 Register 4

This register is reserved.

7.4.1.5 Register 5

This register is reserved.

7.4.1.6 Register 6

Attention: You should access this register only in the reading mode.

Bit	7	6	5	4	3	2	1	0
Signal	free	free	free	free	free	XTESTO	free	free

Description:**Bit 2 XTESTO**

Via this bit, the signal XTESTO of the IM180 can be read out.

Level	Meaning
0	Signal not set
1	Signal set

7.5 Pin Assignment for the Profibus Interface

Data is transmitted in the operating mode RS485 (RS485 physics).

The PROFIBUS interface is designed as 9-pole SUB-D socket with the following pin assignment:

- Pin 1 - not connected
- Pin 2 - not connected
- Pin 3 - B - Line
- Pin 4 - Request to Send (RTS)
- Pin 5 - Ground 5V (**M5**)
- Pin 6 - Potential 5V (**potential free P5**)(load max. 100mA)
- Pin 7 - not connected
- Pin 8 - A - Line
- Pin 9 - not connected

8 Bus Connection

The following standard connectors may be used, according to PROFIBUS DP standard, for connecting the bus:

MLFB-Nr.	Notes	Baudrate:	Color of connector casing
6ES7 972 - 0BA00 - 0XA0	without PG connection	to 1.5 Mbaud	anthracite
6ES7 972 - 0BB00 - 0XA0	with PG connection	to 1.5 Mbaud	anthracite
6ES7 972 - 0BA10 - 0XA0	without PG connection	> 1.5 Mbaud	anthracite
6ES7 972 - 0BB10 - 0XA0	with PG connection	> 1.5 Mbaud	anthracite

Dimension Drawings:

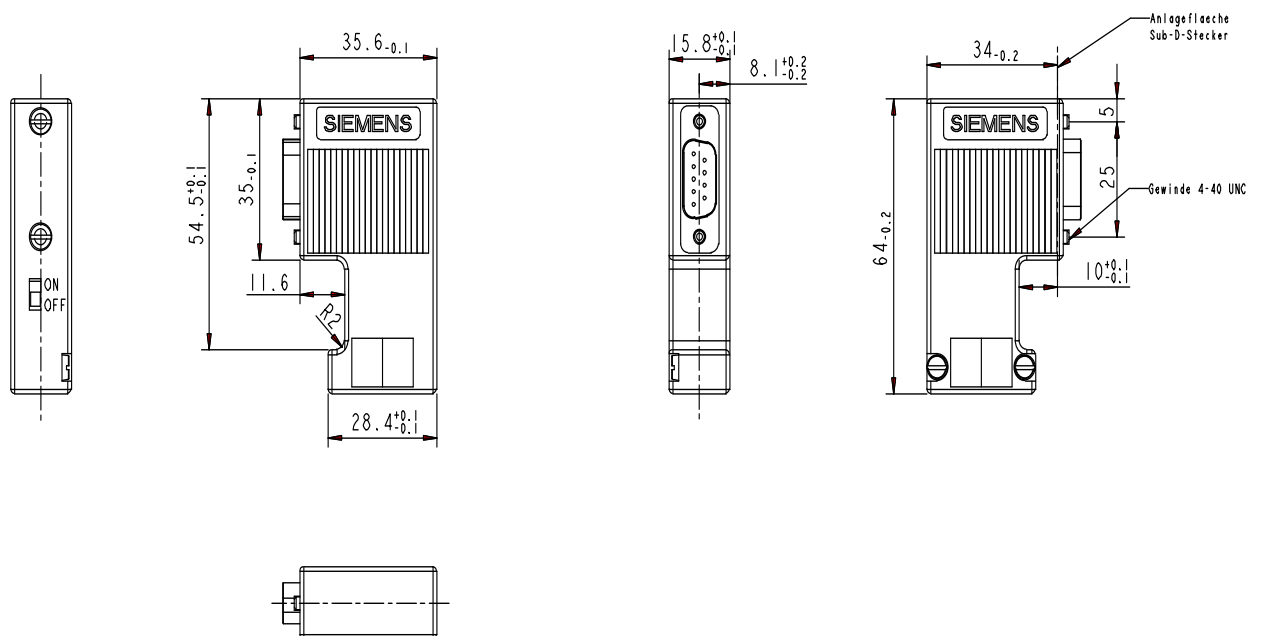

PROFIBUS Connector: 6ES7 972 - 0BA00 - 0XA0 or 6ES7 972 - 0BA10 - 0XA0

9 Error Number

9.1 Error Structure

Type:	Name:	Meaning:
uword	Component	Module Number
uword	Sup -Component	Parts-Number of the Module
uword	Status	Status
uword	Number	Error Number
uword	Detail	Supplement

Table 41: Error parameter

9.2 Components

Name	Number
DPM	0x0001
other AMPRO-DPs	0x0001 - 0x0fff
SUP	0x1001
HAM	0x1002
MCP	0x1003
DAM	0x1004
PAM	0x1005
HCM	0x1006
SYS	0x1007
AMPRO	0x1010
HARDWARE	0x1011

Table 42: Components

9.3 Important Error Numbers

Module	Supmodule	Status	Number	Detail	Explanation
SUP	SUP	any	0x0001	0x0000	Check sum error when loading firmware
SUP	SUP	any	0x0002	0x0000	wrong data in the OTP slot
SUP	SUP	any	0x0003	0x0000	wrong data in the OTP slot
SUP	SUP	any	0x0004	0x0000	wrong data in the OTP slot
SUP	SUP	any	0x0008	0x0000	Error when programming FLASH-EPROM
SUP	SUP	any	0x0009	0x0000	wrong test-sum at LOADER- firmware part
SUP	SUP	any	0x000a	0x0000	wrong test sum at MAIN firmware part
SUP	SUP	any	0x000b	0x0000	Error when deleting parameter info block
SUP	SUP	any	0x000c	0x0000	Error when deleting MAIN block
SUP	SUP	any	0x000d	0x0000	impermissible reset (for example, internal Watchdog)
SUP	SUP	any	0x000e	0x0000	no valid MAIN firmware part available
SUP	SUP	any	0x0010	0x0000	wrong data in the OTP slot
SUP	SUP	any	0x0011	0x0000	Parameter faulty; therefore, load default values
SUP	SUP	any	0x0012	0x0000	Error when deleting parameter data block
SUP	SUP	any	0x0013	INFO	Error 'INFO' at hardware test
HCM	0x0001	any	0x0001	any	Response semaphore in response channel still set
HCM	0x0002	any	0x0001	any	Error when deleting parameter data block
HCM	0x0002	any	0x0002	any	Error when programming FLASH-EPROM
HCM	0x0003	any	0x0001	any	Watchdog for host expired
MCP	0x0001	any	any	any	Error in parameter binary file
MCP	0x0002	any	any	any	Error in parameter binary file

Table 43: Error numbers

For all other error numbers, please contact the pertinent contact persons.

10 General

10.1 Addresses

PROFIBUS Nutzerorganisation

PNO
Agency
Mr. Volz
Haid- und Neu- Strasse 7
76131 Karlsruhe/Germany
Tel.: ++49 (0)721 9658-590
Fax ++49 (0)721 9658-589

Contact persons in the Interface Center in Germany

Siemens AG
AUT 7 B1 TDL2
Mr. Putschky

Mailing Address:

Postfach 2355
90713 Fuerth/Germany

Street Address:
Wuerzburgerstr.121
90766 Fuerth/Germany

Tel.: ++49 (0)911 750 - 2078
Fax: ++49 (0)911 750 - 2100
Mailbox: ++49 (0)911 -737972

PROFIBUS User Organization

PTO
Agency
Mr. Bryant
5010 East Shea Blvd., Suite C-226
Scottsdale, Arizona 85254
+ 602-483-2456
+ 602-483-7202

in the USA

PROFIBUS Interface Center

Tim Black, Rainer Friess

3000 Bill Garland Road
Johnson City, TN 37605-1255

Tel.: (423) - 461 - 2687 / 2332
Fax : (423) - 461 - 2016
BBS:(423) - 461 - 2751

10.2 General Term Definitions

ASPC2	Advanced Siemens PROFIBUS Controller, 2nd Generation
DP	Distributed Periphery

Siemens AG
Division Automation Engineering
Combination Engineering
PO Box 23 55, D-90713 Fuerth/Germany

SIEMENS Aktiengesellschaft

© Siemens AG
Subject to change without prior notice

Printed in the Fed. Rep. of Germany
Order No. 6ES7 180-0AA00-8BA0